

Hy-Lok 105 Series

High Pressure Ball Valves

Catalog No. H-105BV
Apr. 2003

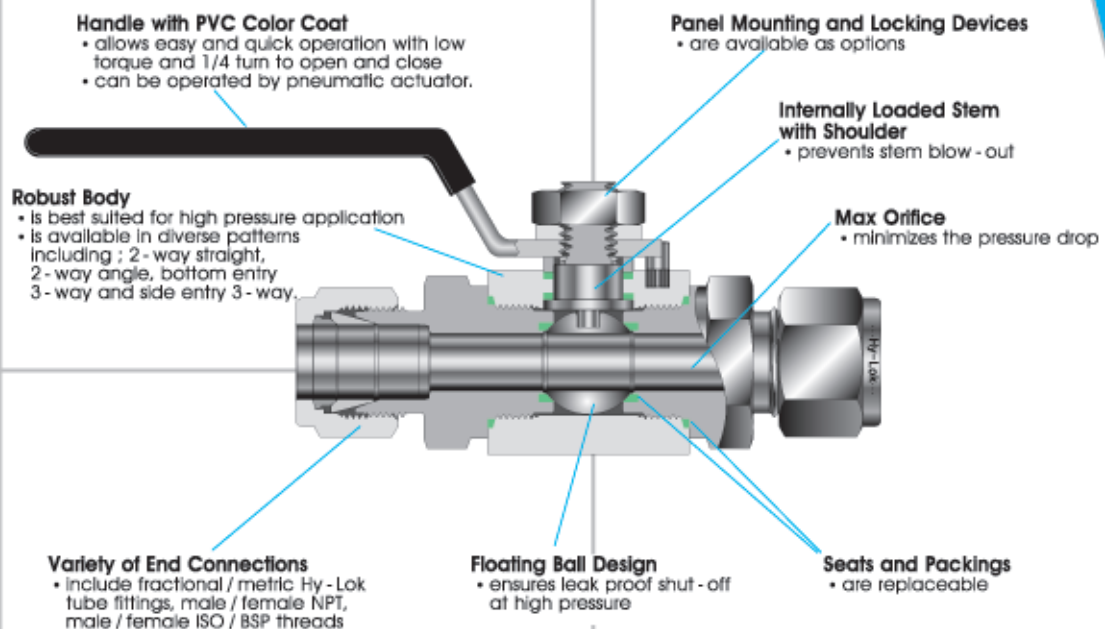

Features

- **Pressure rating** up to 10,000 psig (690bar) @ 70°F(21°C)
- **Temperature rating** from -22°F to 265°F(-30°C to 130°C) with PVDF seat or from -65°F to 500°F (-54°C to 260°C) with PEEK seat
- **Small and compact design**
- **Materials available** in 316 stainless steel and alloy 400
- **100% factory tested.**



HY-LOK CORPORATION

© 1998, 2000, 2002, 2003 HY-LOK CORPORATION all rights reserved

2-Way

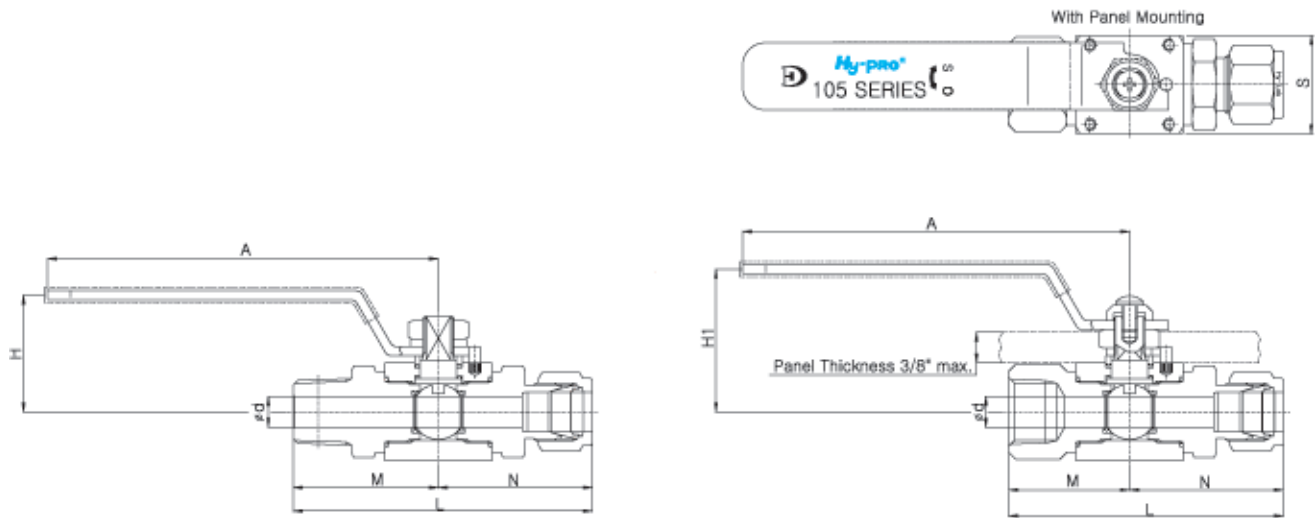
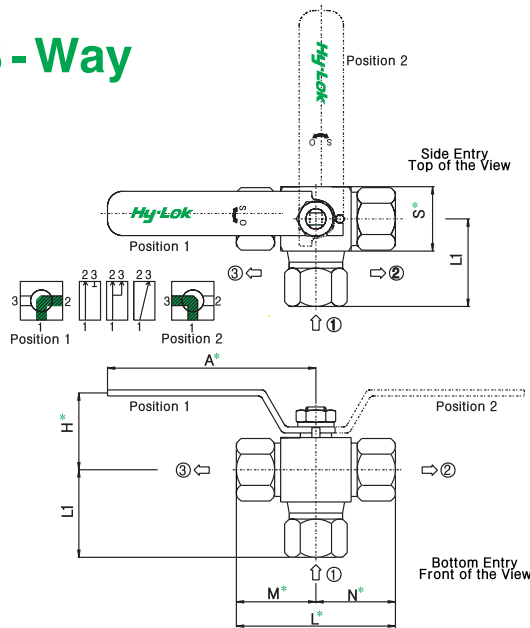

Table of Dimensions

Basic Part No.	Orifice	Cv	End Connections Inlet & Outlet	d Min.	Dimensions										
					M	N	L	H	A	H1	S				
H1B	-H - 4T	10.0	1.2	1/4" Hy-Lok	4.8	45.8	45.8	91.6	38.0	126.5	46.7	32.0			
	-H - 6T		3.7	3/8" Hy-Lok	7.11	47.3	47.3	94.6							
	-H - 8T		7.5	1/2" Hy-Lok	10.0	49.8	49.8	99.6							
	-F - 4N	1/4" Female NPT		32.0		32.0	64.0								
	-F - 6N	3/8" Female NPT		35.5		35.5	71.0								
	-F - 8N	1/2" Female NPT	39.5	39.5	79.0										
	-M - 4N	3.7	1/4" Male NPT	7.11	42.7	42.7	85.4								
	-M - 6N	7.2	3/8" Male NPT	9.65	42.7	42.7	85.4								
	-M - 8N	7.5	1/2" Male NPT	10.0	47.6	47.6	95.2								
H2B	-F - 8N	12.7	10.0	1/2" Female NPT	12.7	45.0	45.0	90.0	50.8	162.0	60.6	40.0			
	-F - 12N			3/4" Female NPT		45.0	45.0	90.0							
	-M - 12N			3/4" Male NPT		52.6	52.6	105.2							
	-H - 10T			5/8" Hy-Lok		55.3	55.3	110.6							
	-H - 12T			3/4" Hy-Lok		55.3	55.3	110.6							
H3B	-F - 12N	19.0	30.0	3/4" Female NPT	20.0	45.0	45.0	90.0	55.6	162.0	65.6	50.0			
	-F - 16N			1" Female NPT		49.1	49.1	98.2							
	-H - 12T			3/4" Hy-Lok		58.3	58.3	116.6							
	-H - 16T			1" Hy-Lok		64.9	64.9	129.8							
	-M - 12N			3/4" Male NPT		57.6	57.6	115.2							
	-M - 16N			1" Male NPT		62.4	62.4	124.8							

All dimensions in millimeters. Dimensions shown with Hy-Lok nuts in finger-tight position, where applicable.

3 - Way



**marked dimensions are the same as of 2 - way valve.

Table of Dimensions

Basic Part No.	Orifice	End Connections		d† Min.	L1
		Inlet & Outlet			
H1B	10.0	1/4" Hy-Lok		10.0	4.8
		3/8" Hy-Lok			7.11
		1/2" Hy-Lok			54.0
		1/4" Female NPT			36.5
		3/8" Female NPT			40.0
		1/2" Female NPT			44.0
H2B	12.7	5/8" Hy-Lok		12.7	65.3
		3/4" Hy-Lok			65.3
		1/2" Female NPT			49.5
		3/4" Female NPT			55.0
H3B	19.0	3/4" Hy-Lok		20.0	69.8
		1" Hy-Lok			69.8
		3/4" Female NPT			56.5
		1" Female NPT			60.6

All dimensions in millimeters. Dimensions shown with Hy-Lok nuts in finger tight position, where applicable.

† See dimension table on page 2

* See ordering information on page 4

Technical Data

Materials of Construction

Description	Grade/ASTM Specification	
	Valve Body Material	
	SS316	Alloy 400
Handle	Stainless Steel with PVC Coating	
Lock Nut	Stainless Steel with Washer	
Pin	Stainless Steel	
Stem	SS316/A276	Alloy 400/B164
Stem Packing*	PTFE	
Ball*	SS316/A276	Alloy 400/B164
Seats*	PVDF (standard)	
End Connector	SS316/A276	Alloy 400/B164
End Seals*	PTFE/Viton	
Body	SS316/A479	Alloy 400/B164

Note : "*" marked are wetted parts.
Lubricant is silicone based.

Handle

- Handle is made of stainless steel with PVC coat in yellow.
- Other colors are available upon request.

Sour Gas Service

- is provided to meet NACE Standard MR - 01 - 75.

Testing

- Each valve is tested with nitrogen @ 1000psig(69bar) to max leak rate of 0.1SCCM.
- Hydrostatic shell test is performed at 1.5 times the working pressure.
- Optional tests are available upon request.

Pressure and Temperature Rating

■ H1B Types

Materials			Pressure Rating @ -65°F ~ 70°F (-54°C ~ 21°C)	Temperature Rating
Seat	Stem Packing	End Seal		
PVDF (standard)	PTFE	PTFE	6,000 psig (410 bar)	-22°F~265°F (-30°C~130°C)
PCTFE				-22°F~355°F (-30°C~180°C)
PEEK			10,000 psig (690 bar)	-65°F~500°F (-54°C~260°C)

■ H2B, H3B Types

Materials			Pressure Rating @ -65°F ~ 70°F (-54°C ~ 21°C)	Temperature Rating
Seat	Stem Packing	End Seal		
PVDF (standard)	PTFE	Viton	5,000 psig (340 bar)	-10°F~375°F (-23°C~191°C)
PCTFE				6,000 psig (410 bar)
PEEK			6,000 psig (410 bar)	

Note

1. The above pressure rating is for 2 - way straight pattern valves. 80% of the above rating shall be applicable to 2 - way angle pattern valves and 3 - way valves.
2. The rated pressure shown above is the maximum allowable pressure to the seat. If the system requires higher pressure to test, the valve must be in open position before and during test so as not to damage the seat.
3. When valves with Hy - Lok Fitting end connections are connected to tubing, the working pressure of tubing must be considered in the calculation of total system working pressure.

High Pressure Ball Valves

105 Series

Panel Mounting

Valve Type	Orifice	d	D	L x L
H1B	10.0	5.0	30.0	26 x 26
H2B	12.7	5.0	38.0	34 x 34
H3B	19.0	5.0	38.0	44 x 44

All dimensions in millimeters.

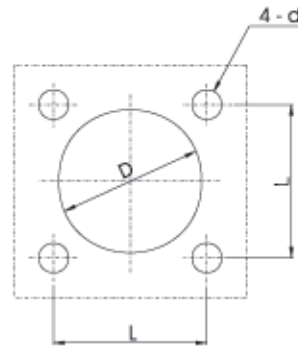

Screw Holes in valves are M4 x 6mm Depth

Torque for Turning Handle (N · m)

Valve Type	Orifice	Working Pressure - psig										
		0	1,000	2,000	3,000	4,000	5,000	6,000	7,000	8,000	9,000	10,000
H1B	10.0	1.6	1.4	1.4	1.6	2.1	2.3	2.7	2.9	3.3	3.7	4.0
H2B	12.7	3.3	2.9	3.8	4.3	5.0	5.2	5.6	-	-	-	-
H3B	19.0	3.2	3.1	4.2	6.5	8.0	8.6	9.6	-	-	-	-

Ordering Information

H1B

3

MH

8N8T

PC

M

O

L

SOG

S316

Valve Type Designator

- H1B : 10.0mm Orifice
- H2B : 12.7mm Orifice
- H3B : 19.0mm Orifice

Pattern Designator*

- Nil : 2-way Straight
- A : 2-way Angle
- 3S : 3-way Side Entry
- 3B : 3-way Bottom Entry

End Connection Designator

- H : All Ends Hy-Lok Tube Fitting.
- F : All Ends Female Thread.
- M : All Ends Male Thread.

Size Designator

- NPT (ISO/BSP)

Thread(in)	1/4	3/8	1/2	3/4	1
Designator	4N(R)	6N(R)	8N(R)	12N(R)	16N(R)

Tube

Fractional Tube	O.D.(in)	1/4	3/8	1/2	3/4	1
Designator		4T	6T	8T	12T	16T
Metric Tube	O.D.(mm)	6	10	12	20	25
Designator		6M	10M	12M	20M	25M

Panel Mounting Option*

- Nil : Without
- M : With

Seat Material Designator*

- Nil : PVDF (Standard)
- PC : PCTFE
- PK : PEEK

Locking Device Option*

- Nil : Without
- L : with

Handle Option*

- Nil : Lever(Standard)
- O : Oval Aluminum (Applicable only for H1B)

Sour Gas Designator*

- Nil : Without (Standard)
- SOG : NACE MR-01-75

Material Designator

- S316 : 316 Stainless Steel
- MONE : Alloy 400(Monel)

Note*: No designator is required for standard items, e.g. H1B-F-6N-S316.

SAFETY in VALVE SELECTION

Proper installation, materials compatibility, operation and maintenance of these valves are the responsibility of the user. The total system design must be taken into consideration to ensure optimal performance and safety.

QUALITY SYSTEM CERTIFICATES



ISO 9001
CERTIFICATE NO. GQC 212

ASME SECT. III (MO)
CERTIFICATE NO. GSC 584

TYPE APPROVALS (for Hy-Lok Tube Fittings)



American Bureau Shipping
CERTIFICATE NO. 00-BK50288-X



Lloyd's Register
CERTIFICATE NO. 01/10075



GERMANISCHER LLOYD
CERTIFICATE NO. 57798-91 HH



DET NORSKE VERITAS
CERTIFICATE NO. P-9100



Distributed by :

www.hy-lok.com