



**SeeGull® IBflex®, IBflex® Lite**

## Hardware Reference Manual

Document Number: 100098-00  
Revision T

---

April 2020

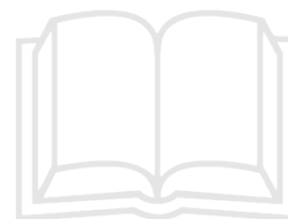



**Table of Contents**

1. Preface .....4

1.1. Purpose.....4

1.2. Applicability .....4

1.3. Notices.....9

1.4. Compliance.....9

2. Overview and System Requirements.....10

2.1. General Description .....10

2.2. Initial Inspection.....10

2.3. Options .....10

2.4. System Requirements .....14

3. Installation.....15

3.1. Integration.....15

3.2. Setup.....17

3.3. LEDs.....18

4. Operation .....19

4.1. Calibration .....19

4.2. Software Upgrades .....19

4.3. Controlling the Scanner and Acquiring Data.....19

4.4. Ethernet Instructions .....20

4.5. CDMA/EV-DO Holdover Operation .....23

4.6. Battery .....23

5. RF Antenna Information.....24

5.1. Antenna Verification.....24

5.2. Cellular Antennas.....24

5.3. Indoor RF Antenna Information .....26

5.4. GPS Antenna Information .....26

5.5. Wi-Fi Wireless Adapter .....27

6. Walk Test Kit Information .....28

6.1. Walk Test Kits.....28

6.2. Bluetooth/Wi-Fi Communications RF Antenna Information .....28

7. Troubleshooting.....29

7.1. No Power: Receiver LEDs not illuminated .....29

7.2. Changing the Fuse in the Power Plug .....29

7.3. Received Signal Strength Appears Low .....29

8. Support .....30

8.1. Contact Information .....30

8.2. Warranty Information.....30

8.3. Calibration Notice.....31

8.4. Return Material Authorization Procedure for the SeeGull IBflex scanning receiver.....31

9.	<i>Appendix A: SeeGull IBflex Specification</i> .....	32
10.	<i>Appendix B: Signal Analyzer Adapter</i> .....	37
11.	<i>Appendix C: NB-IoT Measurements</i> .....	39
11.1.	<i>NB-IoT: Introduction</i> .....	39
11.2.	<i>NB-IoT Physical Layer</i> .....	39
11.3.	<i>Top N NB-IoT Signal Measurement</i> .....	39

**List of Figures**

Figure 1 - SeeGull IBflex Scanning Receiver (without battery pack) .....	10
Figure 2 - SeeGull IBflex Scanning Receiver Top View (without battery pack) .....	15
Figure 3 - SeeGull IBflex Scanning Receiver bottom view (without battery pack) .....	15
Figure 4 - SeeGull IBflex Scanning Receiver Side View (without battery pack) .....	15
Figure 5 - SeeGull IBflex Scanning Receiver Rear View (without battery pack) .....	15
Figure 6 - SeeGull IBflex Scanning Receiver Top View (with battery pack) .....	16
Figure 7 - SeeGull IBflex Scanning Receiver Side View (with battery pack) .....	16
Figure 8 - SeeGull IBflex Scanning Receiver Rear View (with battery pack) .....	17
Figure 9 - SeeGull IBflex Scanning Receiver Front Display .....	18
Figure 10 - SeeGull IBflex Lite Scanning Receiver Front Display .....	18
Figure 11 - Control Panel .....	20
Figure 12 - Network and Internet .....	20
Figure 13 - Network and Sharing Center .....	20
Figure 14 - Change Adapter Settings .....	20
Figure 15 - Local Area Connection Properties .....	21
Figure 16 - Internet Protocol Version .....	21
Figure 17 - Obtain IP Address Automatically .....	21
Figure 18 - IP Address and Subnet Mask .....	22
Figure 19 - OP278H .....	24
Figure 20 - OP278H/OP379H, OP451 and OP278H Gain .....	24
Figure 21 - OP279H and OP379H .....	24
Figure 22 - OP697 wide spectrum multi-band antenna .....	25
Figure 23 - OP451 Wide spectrum multi-band antenna .....	25
Figure 24 - OP034H .....	26
Figure 26 - Supported Wi-Fi Adapters .....	27
Figure 26 - OP412 Walk Test Kit (illustrated showing the side pack strap) .....	28
Figure 27 - SeeGull IBflex Scanning Receiver Power Plug .....	29
Figure 29 - NB-IoT .....	39

**List of Tables**

Table 1: Phone Numbers .....	30
Table 2: Email Addresses .....	30
Table 3: NB-IoT In Band .....	40
Table 4: NB-IoT Guard Band .....	41

## 1. Preface

### 1.1. Purpose

This document is a reference manual for the main features and options available SeeGull IBflex and SeeGull IBflex Lite. **For simplicity, this manual refers to IBflex, which covers features and options available for both the IBflex and the IBflex Lite scanner unless otherwise is noted**, and provides instructions related to setup, operation, and maintenance. Other documentation may supplement this document for SeeGull IBflex and IBflex Lite scanner or related PCTEL products and applications.

### 1.2. Applicability

The SeeGull IBflex scanning receiver conducts in-built walk tests, drive test, and site-specific measurements of mobile networks around the world to optimize wireless network performance, survey tower sites, monitor base stations, demodulate RF signals, and analyze wireless market data.

The SeeGull IBflex scanning receiver is a software-defined receiver, capable of supporting multiple protocols and any supported cellular band. This manual refers to the 08900-E and 08900L-E hardware configurations. The 08900-E and 08900L-E hardware supports frequencies from 10MHz to 6 GHz. The options listed in this document may be limited based on which software licenses has been purchased. It can be configured for FD-LTE, TD-LTE, LTE-LAA, NB-IoT, WCDMA, GSM, CDMA, EV-DO, P25, TETRA, DMR and Wi-Fi technologies which can all be measured simultaneously.

The following 3GPP bands are supported for 5G New Radio (NR)

- N1 (UL: 1920 MHz – 1980 MHz, DL: 2110 MHz – 2170 MHz)
- N2 (UL: 1850 MHz - 1910 MHz; DL: 1930 MHz - 1990 MHz)
- N3 (UL: 1710 MHz – 1785 MHz; DL: 1805 MHz – 1880 MHz)
- N5 (UL: 824 MHz – 849 MHz; DL: 869 MHz – 984 MHz)
- N7 (UL: 2500 MHz – 2570 MHz; DL: 2620 MHz – 2690 MHz)
- N8 (UL: 880 MHz – 915 MHz; DL: 925 MHz – 960 MHz)
- N12 (UL: 699 MHz - 716 MHz; DL: 729 MHz - 746 MHz)
- N14 UL: 788 MHz – 798MHz, DL: 758MHz – 768MHz)
- N18 (UL: 815MHz – 830 MHz, DL: 860MHz – 875MHz)
- N20 (UL: 832 MHz - 862 MHz; DL: 791 MHz - 821 MHz)
- N25 (UL: 1850 MHz - 1915 MHz; DL: 1930 MHz - 1995 MHz)
- N28 (UL: 703 MHz – 748 MHz; DL: 758MHz – 803MHz)
- N29 (DL: 717MHz – 728MHz)
- N30 (UL: 2305MHz – 2315MHz, DL: 2350MHz – 2360MHz)
- N34 (UL/DL: 2010 MHz - 2025 MHz)
- N38 (UL/DL: 2570 MHz - 2620 MHz)
- N39 (UL/DL: 1880 MHz - 1920 MHz)
- N40 (UL/DL: 2300 MHz - 2400 MHz)
- N41/N90 (UL/DL: 2496 MHz – 2690MHz)
- N48 (UL/DL: 3550 MHz – 3700MHz)
- N50 (UL/DL: 1432 MHz - 1517 MHz)
- N51 (UL/DL: 1427 MHz - 1432 MHz)
- N65 Band (UL: 1920 MHz - 2010 MHz; DL: 2110 MHz - 2200 MHz)
- N66 Band (UL: 1710 MHz - 1780 MHz; DL: 2110 MHz - 2200 MHz)
- N70 (UL: 1695 MHz – 1710 MHz, DL: 1995 MHz – 2020 MHz)

- N71 (UL: 653 MHz – 698MHz, DL: 617 MHz – 652MHz)
- N74 (UL: 1427 MHz – 1470 MHz, DL: 1475 MHz – 1518 MHz)
- N75 (1432 MHz – 1517 MHz)
- N76 (1427 MHz – 1432 MHz)
- N77 (3300 MHz – 4200 MHz)
- N78 (3300 MHz – 3800 MHz)
- N79 (4400 MHz – 5000MHz)
- N80 (1710 MHz – 1785 MHz)
- N81 (880 MHz – 915 MHz)
- N82 (832 MHz – 862 MHz)
- N83 (703 MHz – 748 MHz)
- N84 (1920 MHz – 1980 MHz)
- N86 (1710 MHz – 1780 MHz)
- N91 (UL: 832 MHz – 862 MHz, DL: 1427MHz – 1432 MHz)
- N92 (UL: 832 MHz – 862 MHz, DL: 1432 MHz – 1517 MHz)
- N93 (UL 880 MHz – 915 MHz, DL: 1427 MHz – 1432 MHz)
- N94 (UL 880 MHz – 915 MHz, DL : 1432 MHz – 1517 MHz)
- N95 (UL 2010 – 2025 MHz)
- E-UTRA 12/17 Lower 700 MHz A/B/C and Lower 700 MHz B/C)
- E-UTRA 13 (Upper 700 MHz C)
- E-UTRA 13/14L (Upper 700 MHz C and lower half Upper 700 MHz D)
- E-UTRA 14 (Upper 700 MHz D)
- E-UTRA 17 (Lower 700 MHz B/C)
- E-UTRA 18 (Lower 800 MHz Japan)
- E-UTRA 19 (Upper 800 MHz Japan)
- E-UTRA 20 (800 MHz EU)
- E-UTRA 21 (1510 MHz Japan)
- E-UTRA 22 (3500 MHz)
- E-UTRA 23 (2000 MHz)
- E-UTRA 24 (1600 MHz)
- E-UTRA 25 (1990 MHz [Ext. 1900])
- E-UTRA 26 (Upper Ext 850 MHz)
- E-UTRA 27 (Lower Ext 850 MHz)
- E-UTRA 28 (700 MHz APAC)
- E-UTRA 29 (US 700 MHz)
- E-UTRA 30 (2300 MHz WCS)
- E-UTRA 31 (450 MHz)
- E-UTRA 32 (1500 MHz L-Band, DL only)
- E-UTRA 65 (2100+)
- E-UTRA 66 (AWS-3)
- E-UTRA 67 (700 EU, DL only)
- E-UTRA 68 (700 ME)
- E-UTRA 69 IMT-E (2570 - 2620 MHz)(DL only)
- E-UTRA 70 (AWS-4)
- E-UTRA 71 (US 600)
- E-UTRA 72 PPDR, EU PMR/PAMR 450
- E-UTRA 73 APAC 450
- E-UTRA 74 L-Band
- E-UTRA 75 1500 SDL (1432 - 1517 MHz) (DL only)
- E-UTRA 76 1400 (1427 - 1432 MHz) (DL only)
- E-UTRA 85 (Lower 700 A+)
- E-UTRA 252 (5150 - 5250 MHz U-NII-1)
- E-UTRA 255 (5725 - 5850 MHz U-NII-3)

The following bands are supported for FD-LTE with a subset of these bands supported for WCDMA, CDMA, EV-DO and GSM:

- ER-GSM-900
- E-UTRA 1 (2100 MHz UMTS)
- E-UTRA 2 (1900 MHz)
- E-UTRA 2/25 (1900/Ext 1900 MHz)
- E-UTRA 3 (1800 MHz)
- E-UTRA 4 (2100 MHz AWS)
- E-UTRA 4/66 (AWS/AWS-3)
- E-UTRA 5 (850 MHz)
- E-UTRA 6 (850 MHz Japan)
- E-UTRA 7 (2600 MHz IMT)
- E-UTRA 8 (900 MHz UMTS)
- E-UTRA 9 (1700 MHz Japan)
- E-UTRA 10 (Ext. 2100 MHz AWS)
- E-UTRA 11 (1500 MHz Japan)
- E-UTRA 12 (Lower 700 MHz A/B/C)

The following bands are supported for TD-LTE:

- E-UTRA 33 (1900 MHz)
- E-UTRA 34 (2000 MHz)
- E-UTRA 35 (1900 MHz Lower)
- E-UTRA 36 (1900 Upper)
- E-UTRA 37 (1900 MHz Center Gap)
- E-UTRA 38 (2.6 GHz)
- E-UTRA 39 (1.9 GHz)
- E-UTRA 40 (2.3 GHz)
- E-UTRA 41 (2.5 GHz)
- E-UTRA 42 (3.4 GHz)
- E-UTRA 43 (3.6 GHz)
- E-UTRA 44 (700 MHz)
- E-UTRA 45 (TD 1500)
- E-UTRA 46 (5150 - 5925 MHz)
- E-UTRA 47 (5855 - 5925 MHz)
- E-UTRA 48 (3550 - 3700 MHz)
- E-UTRA 49 (3550 - 3700 MHz)
- E-UTRA 50 (1432 - 1517 MHz)
- E-UTRA 51 (1427 - 1432 MHz)
- E-UTRA 52 (3300 - 3400 MHz)
- TDD Proprietary (179 - 199 MHz)
- TDD Proprietary (1785 - 1805 MHz)

The following bands are supported for RSSI channel measurements:

- P25 Public Safety 700 Band (769 - 774 MHz BS and 799 - 805 MHz MS)
- Wi-Fi Bands (2400 - 2484 MHz, 4900 - 6000 MHz)
- TETRA Public Safety 380, 390 Band (380 - 390 MHz MS, 390 - 400 MHz BS)
- TETRA Public Safety 410, 420 Band (410 - 420 MHz MS, 420 - 430 MHz BS)
- TETRA Public Safety 450, 460 Band (450 - 460 MHz MS, 460 - 470 MHz BS)
- TETRA Public Safety 870, 915 Band (870 - 876 MHz MS, 915 - 921 MHz BS)

The following “super” bands are supported for “LTE By Frequency” and EPS measurements:

- LTE Unchannelized Superband (10 MHz - 6 GHz)
- LTE Unchannelized Superband (300 MHz - 3.8 GHz)
- LTE Unchannelized Superband (570 MHz - 3.8 GHz)
- LTE Unchannelized Lower Superband (10 MHz - 1700 MHz)
- LTE Unchannelized Lower Superband (300 MHz - 1700 MHz)
- LTE Unchannelized Lower Superband (570 MHz - 1700 MHz)
- LTE Unchannelized Upper Superband (1700 MHz - 3.8 GHz)
- LTE Unchannelized Upper Superband (1700 MHz - 6 GHz)

For more information about the SeeGull IBflex, please contact your sales or marketing representative (contact information provided in *Section 8*).

## Features

- Fast scanning speeds
- High dynamic range
- Low false detection rate
- Built-in GPS
- LTE MIMO capability (**IBflex Only**)
- Blind Scan for all technologies
- Layer 3 decoding of FD-LTE, TD-LTE, WCDMA and GSM
- USB Interface and Bluetooth® connectivity
- Ethernet connectivity
- On-board storage with SD card (**IBflex Only**)
- Plug-and-play capabilities
- Compatibility with industry-leading drive test, data analysis, and RF planning tools
- Modular architecture for easy upgrades
- Small form factor, light weight
- Low power consumption and hot swap battery system
- Power save mode

## Supported Measurements

### 5G New Radio (NR)

- Maximum # of Channels: 12
- NR Top N Reference Signal Scan
- PCI/Beam Index
- PSS\_RP, PSS\_RQ, PSS\_CINR
- SSS\_RP, SSS\_RQ, SSS\_CINR, SSS\_delay spread
- RSPBCH\_RP, RSPBCH\_RQ, RSPBCH\_CINR, SSB\_RSSI, SSB\_RP, SSB\_RQ, SSB\_CINR, SSB\_idx
- MIB
- Time Offset

### LTE (FDD and TDD)

- Maximum # of Channels: 24
- eTop N Reference Signal Scan

- Automatic Bandwidth detection or manual selection
- P-SCH/S-SCH
- RSRP, RSRQ
- CINR
- Cyclic Prefix
- Time Offset
- Multi-Path Delay Spread (**IBflex Only**)
- MIMO ECQI for different transmission modes (**IBflex Only**)
- MIMO ETPUT for different transmission modes (**IBflex Only**)
- MIMO Condition number (**IBflex Only**)
- Dynamic Spectrum Sharing

### TD-LTE Specific

- Uplink/Downlink Configuration #
- DwPTS Symbol
- UpPTS
- GP

### LTE-LAA

- LTE-LAA measurement for RS and RS-RF Path:
  - RS\_RP
  - RS\_RQ
  - RS\_CINR
  - TimeOffset
- LTE-LAA measurement for SS:
  - PSCH\_RP
  - PSCH\_RQ
  - PSCH\_CINR
  - SSCH\_RP
  - SSCH\_RQ
  - SSCH\_CINR

### NB-IoT

- In-Band, Guard band or Stand Alone
- Top N NRS (Narrowband Reference Signal), NPSS (Narrowband Primary Synchronization Signal) and NSSS

- (Narrowband Secondary Synchronization Signal)
- NRS - RP, RQ, RSSI, CINR, Timeoffset.
  - NPSS - RP, RQ, RSSI, CINR. NSSS - RP, RQ, RSSI, CINR, Timeoffset

**GSM**

- BSIC Decoding Scan
- RSSI Channel Scan
- C/I (Co-Channel Interference)

**WCDMA**

- Maximum # of Channels: 24
- Top N Scan
- P-SCH/S-SCH Scan
- I<sub>o</sub>
- E<sub>c</sub>/I<sub>o</sub> and Aggregate E<sub>c</sub>/I<sub>o</sub>
- Signal to Interference Ratio (SIR)
- Rake Finger Count
- Time Offset
- Delay Spread

**CDMA**

- Maximum # of Channels: 24
- Top N Scan
- E<sub>c</sub>
- E<sub>c</sub>/I<sub>o</sub> and Aggregate E<sub>c</sub>/I<sub>o</sub>
- Pilot Delay and Delay

**EV-DO**

- Maximum # of Channels: 24
- Top N Scan
- E<sub>c</sub>
- E<sub>c</sub>/I<sub>o</sub> and Aggregate E<sub>c</sub>/I<sub>o</sub>
- Pilot Delay and Delay

**W-Fi**

- Channelized RSSI measurements for 2.4GHz, 4.9GHz and 5GHz
- Top N measurement in all channels in the 2.4 GHz and 5 GHz bands
- Signal Strength

- Noise Level
- Channel Number and Bandwidth
- BSSID/Device Name/SSID
- Security Protocol
- 802.11 Media
- Beacon Interval
- Channel Utilization
- UDP Throughput and Lost Packets
- TCP Throughput and OOO Packets

**P25**

- Phase1 and Phase2 RSSI, SINR, NID, FBER and Out of Service BER measurements

**TETRA**

- Channelized RSSI measurements for supported TETRA bands
- Tetra Decode – RSSI, SNR, FBER, Color Code, MCC, MNC

**DMR**

- RSSI, SINR, FBER and Color Code



## MULTI-TECHNOLOGY

- Aggregate Power measurement (RSSI, EPS, or Spectrum Analysis)
- Delay and Signal Strength of neighboring cells
- RSSI Channel Scans
- Spectrum Analyzer measurements
- High Performance GPS Receiver

### Blind Scan

The Blind Scan feature for 5G NR, FD-LTE, TD-LTE, NB-IoT, WCDMA, GSM, CDMA, EV-DO, and Wi-Fi technologies scans the selected band and provides the active channel numbers. Blind Scan is useful for conducting a full band network search where prior knowledge about active channels is incomplete or unknown. It is also beneficial for network benchmarking to obtain a first-glance view of the RF infrastructure density and configuration.

For LTE, Layer 3 option is supported.

### Bluetooth Communication

The Bluetooth Communications enables the user to communicate wirelessly to an Android™ device. Bluetooth requires an antenna to operate and comes with the scanner.

For more information please visit [www.pctel.com](http://www.pctel.com).

### 1.3. Notices

**WARNING:** These devices have no protection against lightning. Please turn off the scanning receiver during a thunderstorm and, if applicable, take the antenna inside the car before a thunderstorm approaches.

The scanning receiver itself is not intended for "in weather" outdoor use.

**NOTICE:** There are no user serviceable parts inside the SeeGull IBflex Scanning Receiver.

### 1.4. Compliance

#### RoHS Compliance

The PCTEL SeeGull IBflex scanning receiver being delivered to participating European nations is compliant to EU Directive 2011/65/EU (RoHS).

The PCTEL SeeGull IBflex scanning receiver is compliant to "Administrative Measure on the Control of Pollution Caused by Electronic Information Products" ("China RoHS").



#### ISO Compliance

PCTEL's Quality Management System has been certified to be compliant with ISO 9001:2015.

## 2. Overview and System Requirements

This section describes the SeeGull IBflex scanning receiver, including the applicable system configuration and software requirements.

### 2.1. General Description

The SeeGull IBflex is a tool for signal strength and modulation measurement, engineered for the rigors of mobile network testing during planning, installation, and maintenance of wireless networks.

### 2.2. Initial Inspection

Upon receipt of the scanning receiver, inspect the shipping container and verify that the contents are complete and match the packing list. The IBflex scanning receiver should look similar to the picture in *Figure 1*. If the contents are incomplete or the SeeGull IBflex scanning receiver appears damaged, please call the Technical Support line at (240) 460-8833.



**Figure 1 - SeeGull IBflex Scanning Receiver (without battery pack)**

### 2.3. Options

Optional multi-technology measurements available for the SeeGull IBflex are described below. These options can be installed at the time of purchase or later on as a field-upgradeable option with the exception of OP641, CDMA/EV-DO Holdover Option. Please contact your PCTEL sales or marketing representative for pricing and delivery information.

#### Technologies Option

The following Technologies option are available on the 08900-E and 08900L-E base configuration:

OP524-GSM	GSM Technology Option
OP524-WCDMA	WCDMA Technology Option
OP524-CDMA	CDMA Technology Option
OP524-EVDO	EVDO Technology Option
OP524-FD-LTE	LTE (FDD) Technology Option
OP524-TD-LTE	TD-LTE Technology Option
OP524-FD-LTE-NB-IOT	LTE (FDD) Narrow Band IoT Technology Option
OP524-LTE-LAA	LTE-LAA (License Assisted Access) Technology Option
OP524-WI-FI	Wi-Fi Technology Option
OP524-NR	NR Technology Option
OP524-P25-Phases 1-2	P25 Phase 1 and Phase 2 Technology Option
OP524-DMR	DMR Technology Option
OP524-DSS	4G LTE - 5G NR Dynamic Spectrum Sharing Option
OP524-TETRA	TETRA Technology Option

#### Enhanced Power Scan (EPS™) Option (OP604)

EPS Mode provides customizable power measurements, improving flexibility and precision over RSSI and Spectrum Analyzer

measurements for highly-tuned analysis of individual parts of the RF signal. EPS features include:

- Absolute Time Stamp
- Auto and Immediate Measurement Modes
- Ability to set both Time and Frequency parameters
- Measure Frequency Spans from 7.5 kHz to 20 MHz user selectable in multiples of 2.5 kHz
- Measures Time Periods from 1 chip (50  $\mu$ s) to 20,000 chips (1sec)

#### **Spectrum Analyzer Option (OP603), IBflex Spectrum Analyzer (08900-E- SPA/08900L-E-SPA)**

The built-in Spectrum Analyzer feature provides an effective means to detect and troubleshoot frequency-related problems. Spectrum Analysis is also available as a package with the scanner that enables spectrum analysis of the wide band capability of the scanner (08900-E-SPA/08900L-E-SPA). The Spectrum Analyzer shows a wealth of information about the signal spectrum that is not obtainable from the standard channel power measurement. The Spectrum Analyzer measures and reports power spectral density using frequency domain techniques (a segmented FFT approach that ensures various resolution bandwidths and fast update rates), whereas RSSI measurements use analog and digital filters to select the right frequency band and subsequently measure total power.

One advantage of this approach is that the Spectrum Analyzer can analyze the fast-changing spectrum of an unstable transmitter. The RSSI measurement in this case will most often show a normal smooth picture, as it averages a limited set of data

over time. The Spectrum Analyzer, however, if used with an appropriate resolution bandwidth, will reveal erratic signal behavior due to its fast update rate and non-averaged data.

The user may set the resolution bandwidth to 5, 10, 20, 40, 80 or 160 kHz or 2, 4, or 8 MHz. Output data may be set to an average of 1, 2, 4, 8, or 16 sweeps.

#### **LTE Power Analysis (OP634)**

LTE Power Analysis is available for TD-LTE and provides power of the resource block and slot of the TD-LTE frame. This enables users to identify interference that is time (slots) or frequency (RBs)-selective, to obtain a snapshot of overall traffic levels, and to determine whether the base station is properly using the available resources.

### Layer 3 Options

(OP621 All Layer 3 Options)

(OP621-GSM)

(OP621-WCDMA)

(OP621-FD-LTE)

(OP621-TD-LTE)

(OP621-CDMA)

(OP621-FD-LTE-NB-IOT)

Layer 3 decoding is available for FD-LTE, TD-LTE, FD-LTE-NB-IOT, GSM, WCDMA CDMA and 5G NR technologies. This option provides decoding for:

- GSM BCCH (Broadcast Control Channel) messages
- WCDMA BCH (Broadcast Control Channel) Type 3 messages

In the GSM BCCH, types 1, 2, 3, 4, 9, and type 13 messages are supported. For WCDMA, and LTE, transport block from the scanner enable support of the Master Information Block (MIB) and System Information Blocks (SIBs).

In the WCDMA BCH, the MIB and SIBs 1, 2, 3, 5, 7, 11 and 19 are available.

In the GSM BCCH, WCDMA, these messages contain the Cell Identity and Local Area Identification information broadcast by the network infrastructure. This information includes the:

- MCC (Mobile Country Code),
- MNC (Mobile Network Code),
- LAC (Location Area Code)
- RAC (Routing Area Code)

These messages also contain significant information on the configuration, activity and

performance of the network. This includes information concerning:

- Neighbor list
- Mobility management (handovers, etc.)
- Group and broadcast call control
- GPRS mobility management, transparent transport and session management
- Radio resource management
- SMS messages
- Location services
- Uplink Interference parameters (WCDMA).

The LTE BCCH Layer 3 option conveys system information about the cell. These transport blocks contain the cell identity, channel bandwidth, mobility management (handovers), neighbor lists, barred cells, intra-frequency selection, public safety messages, etc. It supports decoding of the MIB and SIBs 1-16, 24, 25 and 32.

The FD-LTE NB-IOT Layer 3 option conveys system information about the cell. It supports the decoding of the MIB and SIB 1.

The CDMA Layer 3 option provides this information:

- Synch Message.
- System Parameter Message.
- Extended System Parameter Message.
- Neighbor List Message.
- Extended Neighbor List Message.
- CDMA Channel List Message.
- CDMA Extended Channel List Message



The SeeGull IBflex supports scanning of numerous GSM and LTE BCCH, and WCDMA channels during the same test.

### **GSM C/I Option (OP633)**

A C/I option is standard if GSM Technology is ordered and available as an option for fielded GSM SeeGull IBflex scanning receivers. This option provides co-channel interference (C/I) measurements as well as decoding of BSIC (Base Station Identification Code).

### **Mobile Blindscan Option (Mobile Measurement):**

OP542 - All Technologies  
OP542-GSM  
OP542-WCDMA  
OP542-CDMA  
OP542-EVDO  
OP542-TD-LTE  
OP542-FD-LTE

Mobile Blindscan (Mobile Measurement) combines the functionality to detect new channels in defined Bands, known as Blindscan, and performs additional measurement on the identified channels. When channels are no longer recognized, they are removed from the monitoring channels.

### **LTE (FDD and TDD) 2x2 and 4x2 MIMO Option (OP635) (IBflex Only)**

MIMO testing is available for 2x2 and 4x2 FD-LTE and TD-LTE. This enables users to determine the maximum throughput capability of the RF environment and the degree of correlation between the 2 base station transmission antennas for the purpose of optimizing throughput.

### **Wi-Fi Testing (OP524-WI-FI)**

The Wi-Fi Testing Option enables users to collect measurements for Wi-Fi network using one of our supported USB adapters. Measurements can be conducted on both bands simultaneously, providing detailed information about every detected network. User experience measurements include throughput for UDPO and TCP.

### **CDMA/ EV-DO Holdover (08902(S) Model)**

The Holdover Option enables users to collect measurements even when a GPS signal is not present for CDMA/EV-DO technologies. This option maintains the stability of the internal clock for a greater period in the absence of the GPS signal (normally the GPS signal is used for this). Examples include indoor applications, driving through tunnels or in urban areas, where maintaining GPS (which is used by the IBflex scanning receiver for both location and timing) is difficult. (See Section 3 Operations for more details.)

### **Signal Analyzer Adapter (OP437)**

This adapter for the IBflex scanning receiver simplifies its use in DAS head ends (and other network equipment) for activities such as commissioning and verification. See the appendix below for more details.

### **Dynamic Spectrum Sharing (OP524-DSS)**

This option is available on FD-LTE and TD-LTE for users to accurately measure the LTE frames for cases employing Dynamic Spectrum Sharing with 5G NR.



## 2.4. System Requirements

*This section describes the system requirements for the SeeGull IBflex scanning receiver.*

### Typical System

Depending on a user's requirements, various hardware and software components may be used in the scanning system along with the SeeGull IBflex scanning receiver. However, in most cases, a typical configuration will include a host PC connected to the scanning receiver via a USB cable, or Android tablet or UE connected to the scanning receiver via a USB cable or Bluetooth, running the user's application software.

### Antenna Requirements

Use a 50 Ohm impedance antenna with an SMA male connector at the end of the cable. Refer to PCTEL's product offering matrix in the back of this document for part number information.

**Note:** Outdoor antennas, including those used by other devices, should be placed a minimum of 6 in. (15 cm) apart, with a recommended distance of 34 in. (86 cm).

### Power Source Requirements

Maximum power the SeeGull IBflex scanning receiver draws:

- 18 watts (max), 15 watts (typical)

- 16 watts (max in Power Save mode)
- 10 watts (typical in Power Save mode)

Voltage range for the IBflex scanning receiver:

- 8 to 16 VDC

Use a car battery, a 12-volt battery, or an AC/DC adapter. It is imperative that the power source be capable of supplying the receiver with the voltage and current levels as described above. It is HIGHLY recommended that the power supply not exceed the working DC voltage range of the scanning receiver. Applying excessive voltage to the receiver will void the unit's warranty.

The scanning receiver should be powered through the power cord provided by PCTEL. If another power cord is used, the power cord must be one that incorporates a fuse for protection and safety purposes or this will void any warranties.

### Software Requirements

For supported SeeGull IBflex supported data collection software and technical interfaces, please contact PCTEL support.

### 3. Installation

This section describes how to set up the SeeGull IBflex scanning receiver.

#### 3.1. Integration

There are eight (8) mounting holes (4-40 screw) on the chassis of the unit that are used for mounting in the user's enclosure/rack. Note that the maximum depth of screw insertion from the chassis exterior is ¼". Refer to *Figure 2* and *Figure 4*. Care should be taken when mounting this unit in a system enclosure, rack, or case.

**Note:** Do not place the unit next to the exhaust of another heat source.

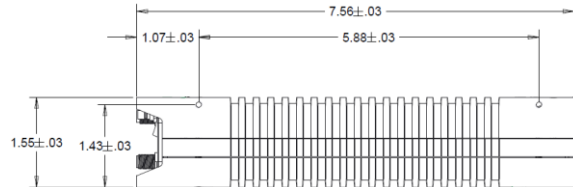

**Figure 4 - SeeGull IBflex Scanning Receiver Side View (without battery pack)**

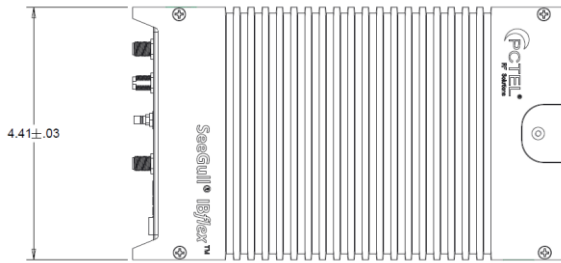

**Figure 2 - SeeGull IBflex Scanning Receiver Top View (without battery pack)**

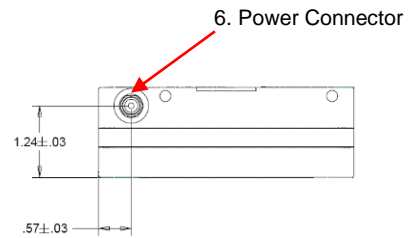

**Figure 5 - SeeGull IBflex Scanning Receiver Rear View (without battery pack)**

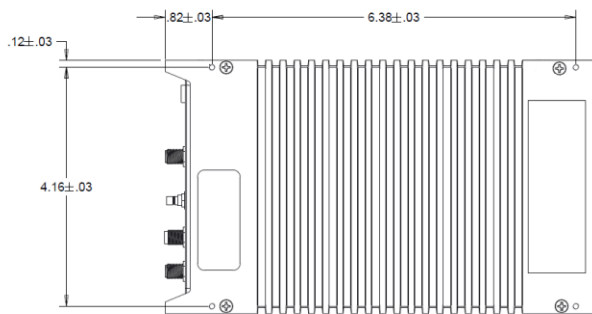

**Figure 3 - SeeGull IBflex Scanning Receiver bottom view (without battery pack)**

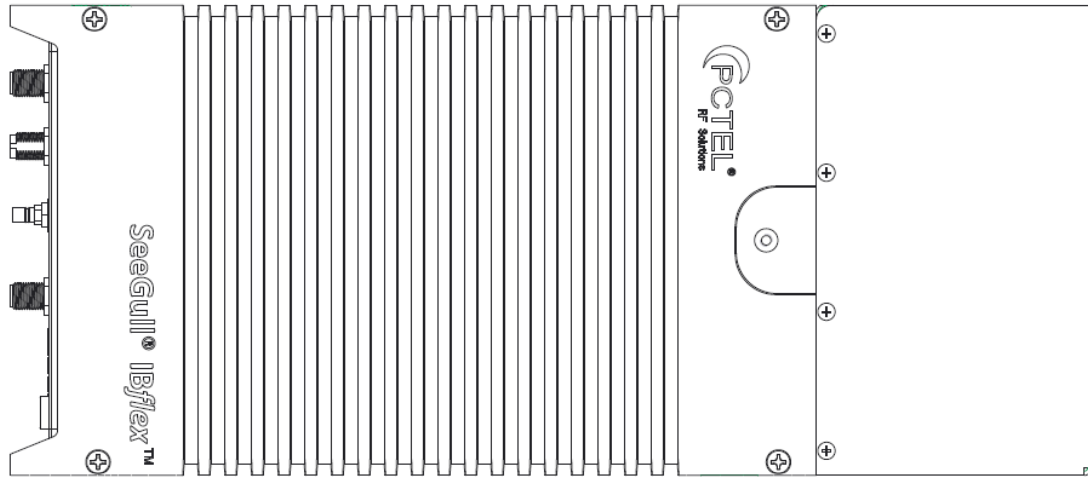

**Figure 6 - SeeGull IBflex Scanning Receiver Top View (with battery pack)**

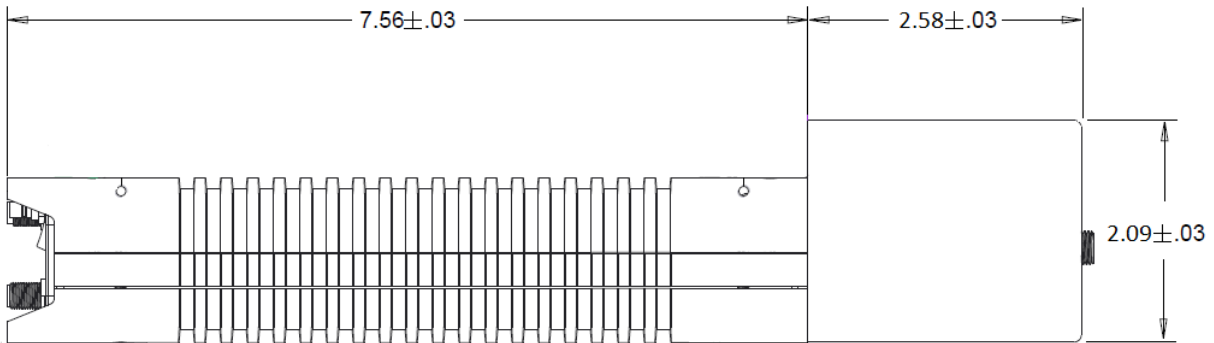

**Figure 7 - SeeGull IBflex Scanning Receiver Side View (with battery pack)**



6. Power connector  
to charge batteries

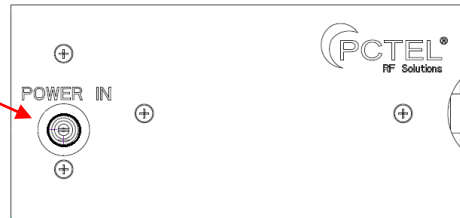

**Figure 8 - SeeGull IBflex Scanning Receiver Rear View (with battery pack)**

### 3.2. Setup

The following steps explain how to connect the unit to the host PC, tablet, or UE, and power source to begin collecting data.

1. Connect the antennas to the SMA connectors on the unit (*Figure 9*). Note that RF2 (**IBflex Only**) is only used for these applications (otherwise, RF2 is inactive):
  - a. LTE MIMO measurements enabled during eTopN scans (**IBflex Only**)
  - b. When setting up scans in different frequency bands while using antennas with different frequency ranges on the different ports (RF1 and RF2) (**IBflex Only**)
  - c. The Signal Analyzer feature in SeeHawk Touch.
2. Connect the GPS antenna (or input) to the SMB connector.
3. If using a USB connection to a Windows laptop or tablet computer, connect the USB cable to both the SeeGull IBflex scanning receiver (COM port) and to a PC USB port.
4. If using an Ethernet connection, the IBflex must be connected to a network or the user's laptop. Connect an Ethernet cable to the LAN connector on the unit.
5. If using a Bluetooth connection to connect to an Android device or Wi-Fi Communications to a computer, connect Wi-Fi/Bluetooth antenna to the SMA connector on the unit.
6. For Wi-Fi testing, insert the Wi-Fi Adapter (with extender) into the USB port.
7. Connect the power cable to the SeeGull IBflex scanning receiver (*Figure 5*) and to the car Power Socket or insert the battery pack for in-building testing (*Figure 8*). After the power is applied, the SYS LED on the receiver blinks orange. After a short delay, the light turns green (*Figure 9*). If the light turns dark red, the unit has failed the power-up test. Please contact Customer Support.

8. Turn on power switch. The “Psave” position lowers the power consumption to 10 watts for cellular technology testing (Wi-Fi testing and/or Wi-Fi/Bluetooth Communications increases power consumption).
9. If saving data to SD card, insert SD card into SD port. SD card use is limited to 32 Gigabytes. (**IBflex Only**)
10. If you are using a Windows computer: Install and start the collection software. The system is now ready for use.
11. If using an Android device: Refer to the Application User Manual. The system is now ready for use.

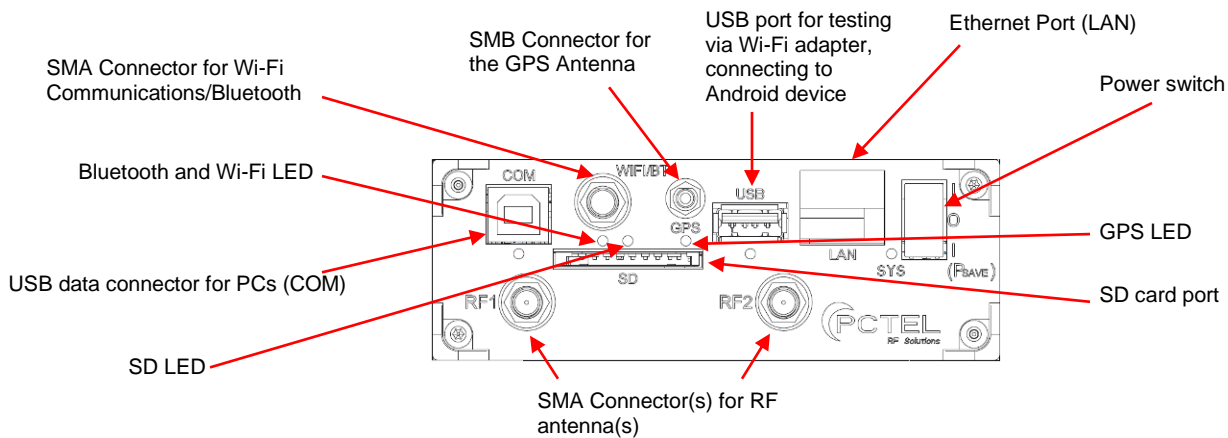

**Figure 9 - SeeGull IBflex Scanning Receiver Front Display**

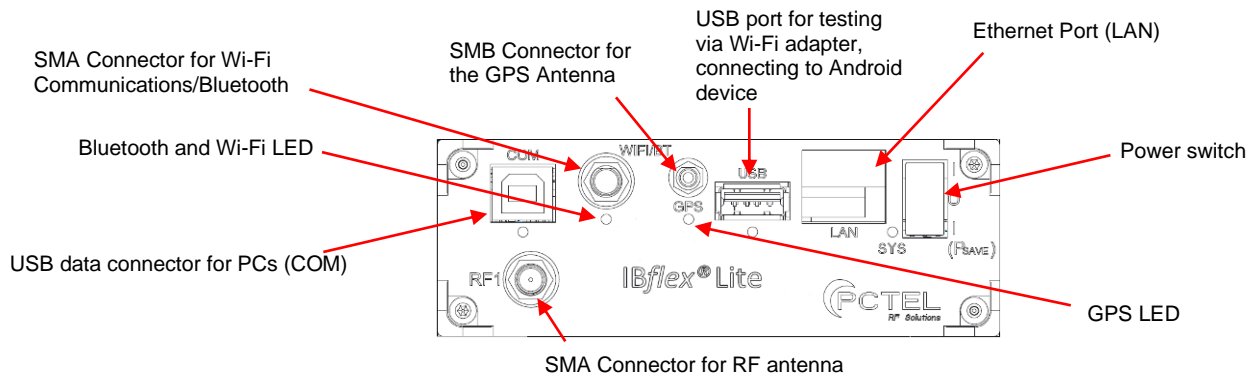

**Figure 10 - SeeGull IBflex Lite Scanning Receiver Front Display**

### 3.3. LEDs

The **GPS LED** colors indicate the following states:

- Green: GPS module locked to GPS signal

- Amber: GPS module unlocked Flashing  
Amber: Lost GPS lock within past 5 seconds
- Red: System Error
- Purple: GPS not trained (may take up to 30 minutes and will only occur after a software upgrade from early software versions)

The **System LED** turns solid green after the successful boot up of the system. It turns solid red or blinking green if the boot up is faulty. It turns blinking red if the firmware is terminated abnormally due to an internal error. It turns blinking amber if an internal communication error is detected.

The **SD card LED (IBflex Only)** is normally off. When the unit is writing to the SD card it turns solid green. If the SD card is full the LED color is red. If the card is ejected during a write operation and error is detected the LED color is orange.

If the IBflex has the Bluetooth option, then the **Bluetooth LED** is blue. The unit is in discovery mode during this period. Once another device connects to scanner application via Bluetooth, the LED turns off and the scanner is no more discoverable. After this, the LED turns off and will blink during data transfer. When the other device disconnects, the LED turns solid blue again.

The **Com port LED** blinks green during data transfer.

## 4. Operation

*This section discusses calibration, software upgrades, and integrating the SeeGull IBflex*

*scanning receiver into the user's test system.*

### 4.1. Calibration

SeeGull IBflex scanning receivers are calibrated at the factory. The calibration data is stored in the internal non-volatile memory for each 1 dB step for the whole input signal dynamic range. Recalibration is recommended every 2 years in order to maintain the specified accuracy levels. Please refer to the Calibration Notice in the Support section for more information. Recalibration is available as an optional service from PCTEL Inc..

**Note:** It is highly recommended to have the SeeGull IBflex scanning receiver recalibrated every 2 years.

### 4.2. Software Upgrades

SeeGull IBflex scanning receiver stores the application program in internal non-volatile memory, and accordingly, is capable of being upgraded via software. Upgrades may be needed to incorporate new features or bug fixes. Most software upgrades can be done remotely using PCTEL's SeeGull Assistant. Please note that some upgrades can only be performed at PCTEL's factory.

### 4.3. Controlling the Scanner and Acquiring Data

A unit is controlled, and the measurement data is received via the USB data cable for PC, or Bluetooth for Android tablet or UE. Control of the SeeGull IBflex scanning receiver is dependent upon the software in order to collect data coming from measurements taken from the SeeGull IBflex scanning receiver.

#### 4.4. Ethernet Instructions

The Ethernet feature enables TCP/IP communication between IBflex and a control PC (or laptop). PC DHCP connection is recommended for remote access to the scanner. The user also has the option of manually entering a Static IP Address.

**Note: If the TCP socket connection is lost without a proper shutdown, the scanner must be power cycled before accepting a new connection.**

#### Ethernet Using DHCP

Using this method, an IP address, Subnet mask, and Gateway are acquired on the PC automatically from a DHCP server. The scanner is then assigned a corresponding IP address with identical Subnet mask using SeeGull Assistant. Make sure the selected IP address for Scanner is not in use or duplicated.

#### Set Up PC:

1. Click Start menu, then click on Control Panel.

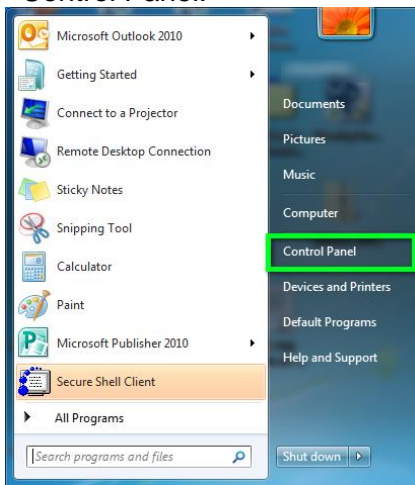

Figure 11 - Control Panel

2. Click Network and Internet.



Figure 12 - Network and Internet

3. Click Network and Sharing Center.

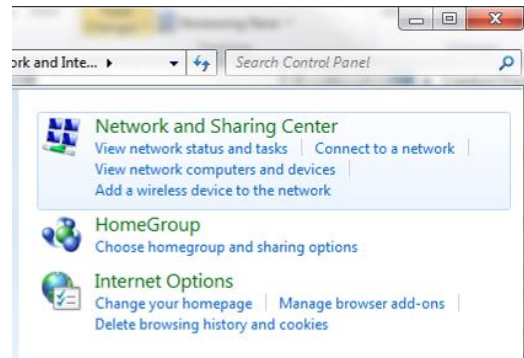

Figure 13 - Network and Sharing Center

4. Click Change adapter settings.

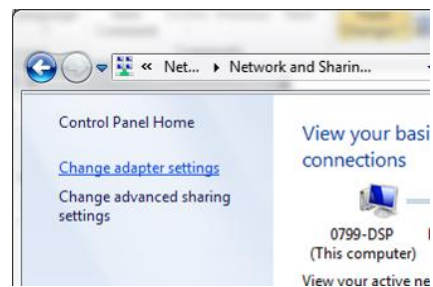

Figure 14 - Change Adapter Settings

5. Right-click Local Area Connection icon, then click Properties.

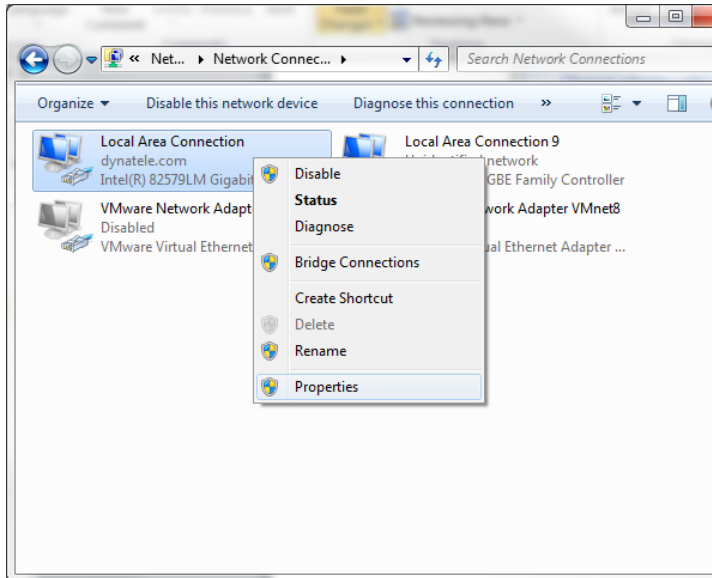

Figure 15 - Local Area Connection Properties

7. Select Obtain an IP address automatically and click OK.

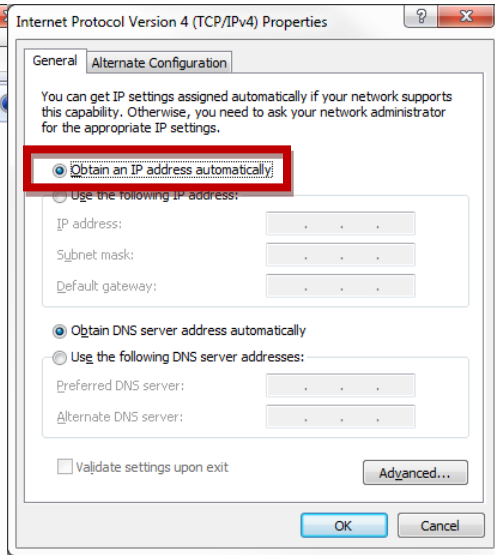

Figure 17 - Obtain IP Address Automatically

6. Double-click Internet Protocol Version 4 (TCP/IPv4).

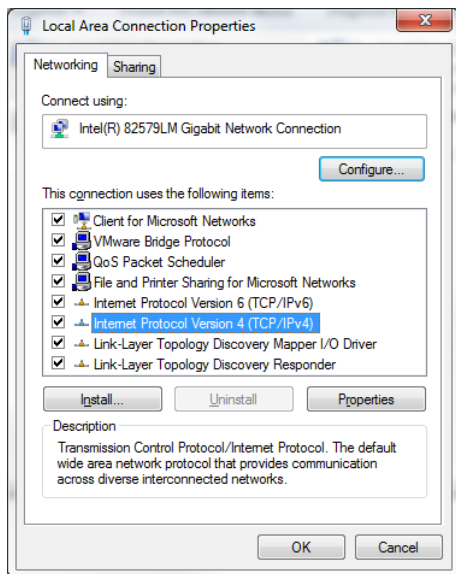

Figure 16 - Internet Protocol Version

### Set Up Scanner

After the IP address and Subnet mask are confirmed for the PC, the scanner must be assigned a corresponding IP address and identical Subnet mask using SeeGull Assistant. Please refer to the SeeGull Assistant User Guide for more information.

**NOTE: The SeeGull Assistant application is available at PCTEL’s website under the support page.**

**Note: Consult your IT department to confirm IP Address and Subnet mask for the PC and then to Assign corresponding address and identical Subnet mask to the scanner.**

The IP address network identification must be identical to the connected PC’s IP address. The IP address host cannot be identical to the connected PC.

The subnet mask number must be identical for both the scanner and connected PC.

**Example:**

PC:  
 IP Address: XXX.YYY.ZZZ.**2**  
 Subnet Mask: 255.255.255.0

Scanner:  
 IP Address: XXX.YYY.ZZZ.**100**  
 Subnet Mask: 255.255.255.0

**IP Address Note:**

XXX.YYY.ZZZ is the network identification and is identical for the PC and scanner.

The bold numbers are the host identification and cannot be identical.

**Default Network Configuration:**

The IBflex comes with the following default network configuration:

DHCP: Disabled  
 IP Address: 192.168.2.100  
 Subnet mask: 255.255.255.0  
 Default Gateway: None

**Note: IBflex scanners purchased before release v1.3 require a firmware upgrade to enable the free Ethernet option. Updating firmware will not autofill the default network configuration. The user must manually enter desired configuration using SeeGull Assistant.**

**Ethernet Using Static IP Address:**  
 Using this method, an IP address and Subnet mask are entered in to the PC manually using numbers assigned by your IT Department. A corresponding IP address and identical Subnet mask are then assigned to the scanner using SeeGull Assistant.

**Set Up PC**

Repeat steps 1-6.

8. Select Use the following IP address.

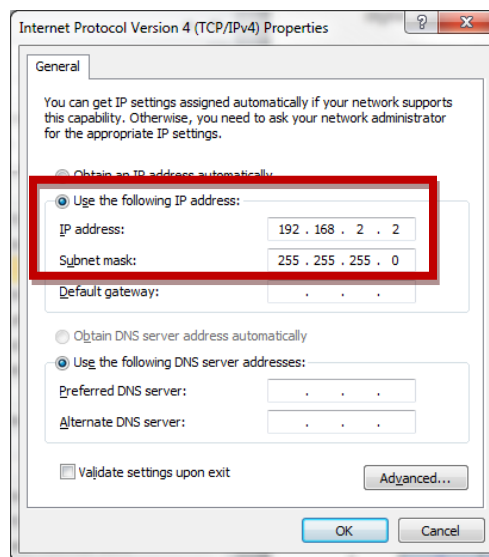

**Figure 18 - IP Address and Subnet Mask**

9. The default network configuration of IBflex may be used for the PC's IP address and Subnet mask. It is recommended to confirm with your IT department. Enter numbers and press OK.

**Set Up Scanner:**

After the IP address and Subnet mask are confirmed for the PC, the scanner must be assigned a corresponding IP address and identical Subnet mask using SeeGull Assistant. Please refer to the SeeGull Assistant User Guide for more information.

**Note: Consult Your IT Department to Assign IP Address and Subnet mask for the Scanner.**



The IP address network identification must be identical to the connected PC's IP address. The IP address host cannot be identical to the connected PC.

The subnet mask number must be identical for both the scanner and connected PC.

**Example:**

PC:

IP Address: 192.168.2.**2**

Subnet Mask: 255.255.255.0

Scanner:

IP Address: 192.168.2.**100**

Subnet Mask: 255.255.255.0

**IP Address Note:**

192.168.2 is the network identification and are identical for the PC and scanner.

The bold numbers are the host identification and cannot be identical.

**4.5. CDMA/EV-DO Holdover Operation**

When a GPS signal is present, CDMA and EV-DO technologies use the GPS data for timing information to decode the signals. With the Holdover option, the SeeGull IBflex will continue to accurately decode the pilots and cell IDs for a period of 4 hours in the absence of any GPS signal. To get the best performance of the Holdover option during indoor measurements, we recommend that the GPS be locked for at least 30 minutes before using the SeeGull IBflex scanning receiver in an unlocked / holdover mode (with power maintained). The 30 minutes applies to units with serial number 81607xxx or higher, or those that have the applicable modification applied by PCTEL. Contact Customer Service for more information.

**4.6. Battery**

Dispose of used batteries properly. Do not disassemble and do not dispose of in fire. Replace battery with PCTEL OP429 (or Inspired Energy® model NC2040HD34) only. Use of another battery may present a risk of fire or explosion.

Entsorgen Sie verbrauchte Batterien ordnungsgemäß. Nicht zerlegen und nicht ins Feuer werfen. Um den Akku auszutauschen, nur PCTEL OP429 (oder Inspired Energy® Modell NC2040HD34). Verwendung einer anderen Batterie kann eine Brandgefahr und Explosionsgefahr präsentieren.

## 5. RF Antenna Information

This section discusses antennas that are used with the SeeGull IBflex scanning receiver system.

### 5.1. Antenna Verification

Verify that all the necessary antennas are included in the shipment and that each is marked. Each antenna comes in a bag labeled with the antenna's model number and its corresponding frequency range, while the antenna itself is labeled by the frequency range.

### 5.2. Cellular Antennas

PCTEL offers several antennas that are industry superior antennas supporting low dB loss cable, extended temperature ranges and a frequency range wide enough to cover PCTEL's SeeGull IBflex scanning receiver.



Figure 19 - OP278H

The OP278H supports a wide frequency range from 698 MHz to 3.8 GHz. The antenna gain is shown in *Figure 20*. The antenna comes standard with a magnetic mounting base and a male SMA<sup>2</sup> connector for the RF, as shown in *Figure 19*.

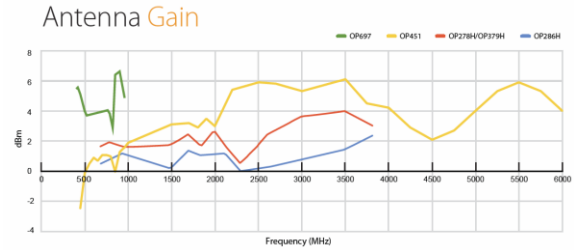

Figure 20 - OP278H/OP379H, OP451 and OP278H Gain

The OP379H shown in *Figure 21* supports a wide frequency range from 698 MHz to 3.8 GHz. The antenna gain is shown in *Figure 20*. These antennas come standard with a male SMA<sup>2</sup> connector for the RF and an SMB (push-on/pull-off) adapter for the GPS.



Figure 21 - OP379H

PCTEL's PCTWSLMR wide spectrum multi-band antenna (*Figure 23*) supports multi-band radio technology to provide interoperability among emergency management and response personnel, regardless of the frequency band used. It provides outstanding coverage of VHF and UHF bands, including 700 MHz public safety, 800 MHz and 900 MHz



frequencies in a ready-to-install, no tune design. Its multi-band elements are housed in a rugged, impact-resistant housing for maximum durability and its base is designed to interface with standard NMO mobile mounts to facilitate existing installation upgrades on public safety vehicles.



**Figure 22 - OP697 wide spectrum multi-band antenna**

For wide range measurements PCTEL provides OP451 omni directional antenna (Figure 23). This antenna has a range from 450MHz – 6GHz and it's a multi band mag mount high performance antenna.



**Figure 23 – OP451 Wide spectrum multi-band antenna**

### 5.3. Indoor RF Antenna Information

PCTEL offers wideband rubber duck style antennas for indoor use. There are two models depending on the frequency required.

- OP691: Indoor Antenna, 600 MHz - 6 GHz



Figure 24 - OP034H



- OP452: Indoor Antenna, Public Safety VHF/UHF/ 700 MHz/ 800 MHz



### 5.4. GPS Antenna Information

PCTEL offers a single standalone GPS antenna, the OP034H. The OP034H is a High Gain GPS standalone antenna which comes standard with a magnetic mounting base and a SMB connector. See *Figure 24*.

**5.5. Wi-Fi Wireless Adapter**

For Wi-Fi testing, PCTEL offers wireless adapters for purchase; there are others we have tested and support (see the table below). The wireless adapter (with an extension adapter) is connected to the USB port on the front panel of the IBflex.

Wi-Fi Device	802.11 Version	Security Mode	PCTEL OP #
Proxim ORiNOCO USB-9100 (US, WD)	a/b/g/n/ac	WEP, WPA Personal, WPA2 Personal and Open Network	OP614-US
Ubiquiti Networks SR71-USB	a/b/g/n	WEP and Open Network	N/A
D-Link DWA-182 Rev C1	a/b/g/n/ac	WEP, WPA Personal, WPA2 Personal and Open Network	N/A
Planex GW-900D	a/b/g/n/ac	WEP, WPA Personal, WPA2 Personal and Open Network	N/A
ASUS USB-AC56	a/b/g/n/ac	64-bit WEP, 128-bit WEP, WPA2-PSK, WPA-PSK, WPA-Enterprise , WPA2-Enterprise , WPS support	OP614-WD

**Figure 25 – Supported Wi-Fi Adapters**

## 6. Walk Test Kit Information

*This section discusses walk test options that can be used with the SeeGull scanning receivers.*

Deployment of wireless data services is resulting in further increases of in-building traffic and coverage requirements. The design, testing, and optimization of indoor coverage are now an increasingly important aspect of wireless engineering.

The PCTEL SeeHawk Walk Test Kit comprises a complete set of accessories that enable the indoor use of the PCTEL SeeGull IBflex scanning receiver. The Walk Test Kit provides a cost-effective solution for evaluating existing in-building coverage and for planning, deploying, and testing indoor coverage systems.

The PCTEL's Walk Test Kit provides the right solution for "Walk Testing" that enables wireless engineers to address the three key steps of in-building coverage assessment and planning:

- Evaluating In-building Coverage from Outside Networks
- Planning New In-Building Networks
- Coverage Validation for New or Existing In-Building Networks

### 6.1. Walk Test Kits

PCTEL offers a Walk Test Kit for the SeeGull IBflex scanning receiver, the OP412 Walk Test Kit as shown in *Figure 26*. It delivers a convenient way to carry and power the SeeGull IBflex scanning receiver for in-building measurements. The OP412 Walk Test Kit consists of:

- Carrying case
- Battery Pack w/ Battery Case (also serves as a battery charger)
- AC Power supply with US power cord

The IBflex Walk Test Pack is flexible allowing the user to carry the IBflex as a side pack or a backpack configuration.

Note: The Walk Test Kit comes without indoor antenna(s). The Bluetooth option must be ordered separately if not already installed on the IBflex.



**Figure 26 - OP412 Walk Test Kit (illustrated showing the side pack strap)**

### 6.2. Bluetooth/Wi-Fi Communications RF Antenna Information

The use of Bluetooth or future Wi-Fi Communications requires an antenna for operation which comes standard with the option OP636 Bluetooth Communications Option.

## 7. Troubleshooting

*This section describes a few suggestions for several common problems that might occur. These suggestions are user serviceable.*

### 7.1. No Power: Receiver LEDs not illuminated

If the SYS LED located on the face of the scanning receiver is not illuminated, please check the power connection first, then the fuse, which is located in the Power Plug end of the power cord.

**Note:** Check the fuse in the Power Plug first.

The fuse can be “blown” by a surge in the portable or mobile battery system. A temporarily shorted wire can also cause other problems.

If the fuse is not operating normally, it will open up, thereby disconnecting the input power from the SeeGull IBflex scanning receiver. The fuse is the first line of defense should any short circuit, large spike, or other problems occur within the power wiring circuitry. When the fuse “blows”, there will be no power to the receiver.

### 7.2. Changing the Fuse in the Power Plug

If it is necessary to change the fuse in the power plug, remove the Power Plug end from the power source. See *Figure 27* for an illustration of the power plug.

Loosen the fuse-holding finger nut by turning it counter-clockwise until the plug comes apart. The fuse is inside the power plug housing and can be removed.



**Figure 27 - SeeGull IBflex Scanning Receiver Power Plug**

Replace the fuse with an identical 3-amp fuse.

**Note:** Only use a 3-amp fuse (IBflex); any other fuse value may cause severe problems with the unit and void the warranty. In order not to violate the safety approval of the receiver, the fuse must be safety approved.

Insert the new fuse in the housing and re-assemble the plug by turning the knurled finger nut in a clockwise direction. Tighten this nut as tight as you can with your fingers.

**Note:** Do not use tools to tighten.

### 7.3. Received Signal Strength Appears Low

If the received signal strength appears to be lower than expected, it is likely that (1) an incorrect antenna is being used, (2) an antenna is not properly connected or (3) the antenna or antenna cable is damaged.

Check that the antenna is properly connected to the scanning receiver, and that the antenna is of the correct frequency.



## 8. Support

*This section provides support information, including contacts, warranty information, calibration notice, and technical specifications.*

### 8.1. Contact Information

Phone Numbers	
Departments	Contact Information
CUSTOMER SUPPORT / RMA REQUESTS	+1-240-460-8833
QUALITY MANAGER	+1-301-444-2045

**Table 1: Phone Numbers**

Email Addresses	
Departments	Contact Information
PRODUCT FEEDBACK	PRODUCTFEEDBACK@PCTEL.COM
CUSTOMER SUPPORT / RMA REQUESTS	SUPPORT.RFSG@PCTEL.COM
QUALITY MANAGER	QUALITY.RFSG@PCTEL.COM

**Table 2: Email Addresses**

### 8.2. Warranty Information

#### WARRANTY

PCTEL warrants that the Product will be free from defects in material and workmanship for a period of five (5) years for IBflex and two (2) years for IBflex Lite, from the date of shipment under normal use and operation. PCTEL’s sole and exclusive obligation under the foregoing warranty shall be, at its option, to repair or replace any defective Product, which fails during the warranty period, provided that PCTEL receives written notice of the defect during

the warranty period. The expense of removal and reinstallation of any item(s) of equipment is not included in this warranty. This warranty shall only apply to the Product purchased or licensed and shall not apply to any other equipment and its removal and reinstallation. THE FOREGOING WARRANTY IS EXCLUSIVE AND IN LIEU OF ALL OTHER WARRANTIES, EXPRESS OR IMPLIED, INCLUDING THE IMPLIED WARRANTIES OF MERCHANTABILITY OR FITNESS FOR A PARTICULAR PURPOSE. Repair or replacement in the manner provided above shall be the sole and exclusive remedy of Buyer for breach of warranty and shall constitute fulfillment of all liabilities of PCTEL with respect to the quality and performance of the Products. PCTEL shall have no obligation to make repairs or replacement necessitated by catastrophe, fault, negligence, misuse, abuse or accident of Buyer or other users. IN NO EVENT SHALL PCTEL BE LIABLE FOR ANY SPECIAL, INCIDENTAL OR CONSEQUENTIAL DAMAGES TO BUYER OR ANY THIRD PARTY ARISING OUT OF THESE TERMS AND CONDITIONS OR ANY DEFECTIVE PRODUCT WHETHER THE DEFECT IS WARRANTED AGAINST OR NOT, WHETHER THE CLAIM IS BASED UPON CONTRACT, TORT, STRICT LIABILITY OR OTHERWISE, NOR SHALL PCTEL BE LIABLE TO BUYER FOR ANY AMOUNT EXCEEDING THE PURCHASE PRICE OF THE PRODUCT.

#### Warranty Procedures

See Return Material Authorization (RMA) Process further below.

### 8.3. Calibration Notice

**Note:** It is highly recommended to have the SeeGull IBflex scanning receiver recalibrated every 2 years.

SeeGull IBflex scanning receiver is calibrated at the factory. The calibration data is stored in the internal non-volatile memory in 1 dB steps for the whole input signal dynamic range. Recalibration is recommended every 2 years in order to maintain the specified accuracy levels. Recalibration is available as an optional service from PCTEL.

The SeeGull IBflex scanning receiver is calibrated for several sources of variations including amplitude levels, ambient temperature, input frequency, and internal noise levels for narrow and wide channel bandwidths. The calibration parameters are stored as single values or arrays in the scanning receivers' non-volatile memory. Automated test and calibration stations use proprietary software which performs the process with no or minimum human intervention. The calibration process is followed by a fully automated production test. The test results are stored in a central quality database and they are extracted and used for periodic quality audits.

Every unit that passes the calibration and test process successfully receives a Certificate of Calibration. This Certificate is shipped back with the unit.

The complexity of the calibration process precludes field calibration. It is highly recommended that PCTEL's scanning receivers be returned to the factory annually

to maintain the units' exceptional measurement capability.

### 8.4. Return Material Authorization Procedure for the SeeGull IBflex scanning receiver

**NOTICE:** There are no user serviceable parts inside the SeeGull IBflex receiver. *Any tampering with the components within the unit will void any applicable warranties.*

All repairs must be performed by PCTEL in accordance to the procedure outlined below:

1. Complete the RMA form on the website at:  
<http://pctel.com/rma>
2. A response including an RMA number and in-warranty or out-of-warranty information will be provided within 24 hours, or the next working day.
3. Please ship the unit to:  
**PCTEL, Inc.**  
Attn: RMA Coordinator  
22600 Gateway Center Drive Suite 100,  
Clarksburg, MD 20871  
+1 (240) 460-8833
4. Reference PCTEL's RMA number on all shipping documentation.

**Note:** Units shipped without an RMA number may be returned to the customer without the unit being repaired.

### 9. Appendix A: SeeGull IBflex Specification

<b>5G New Radio</b>	Measurement Modes	NR TopN Signal : Synchronization channels (P-SS/S-SS) & PBCH, SSB, Blind Scan	
	Data Modes	PCI, PSS-RP [dBm], SSS-RP [dBm], PSS-RQ [dB], SSS-RQ [dB], SS-CINR [dB], SSS-CINR [dB], RSPBCH-RP [dBm], RSPBCH-RQ [dB], RSPBCH-CINR [dB], SSB-RP [dBm], SSB-RQ [dB], SSB-CINR [dB], SSB-idx, SSB-RSSI, SSS-Delay Spread, Time Offset	
	Channel Bandwidths	15/30KHz	
	Max. Number of Channels	12	
	Measurement Rates:	30/sec	
	Dynamic Range (CINR)	PSS/SSS PBCH DMRS CINR	-10 to +33 dB -8 to +40 dB
	Min. Detection Level:	RP	-132 dBm (SCS @ 15 KHz)
	Relative Accuracy (CINR):	PSS/SSS CINR	±2 dB

<b>FD-LTE and TD-LTE</b>	Measurement Modes	Top N Synchronization Channel Reference Signal, (P-SCH/S-SCH), and Resource Block (Wideband, Subband); Layer 3 Reporting; Unicast Synchronization Channel Reference Signal and (P-SCH/S-SCH), Dynamic Spectrum Sharing	
	Data Modes	RP, RQ, CINR, Cyclic Prefix, Time Offsets, Delay Spread; MIMO: Condition Number, ECQI, EPUT	
	Channel Bandwidths	1.4 / 3 / 5 / 10 / 15 / 20 MHz	
	Max. Number of Channels	24	
	Receive Modes	SISO; MIMO (2x2) (MIMO – <b>IBflex Only</b> )	
	Transmit Antenna Configurations	1, 2, 4 (with path measurement)	
	Measurement Rates:	Sync Channel RS Multicast RS	LTE FDD: 50/sec; TD-LTE: 25/sec
	Dynamic Range (CINR) @10 /15/20 MHz	RS P-SCH/S -SCH Multicast RS	-26 to +40 dB -10 to +18 dB -9 to +30 dB
	Min. Detection Level:	RSRP	-140 dBm (RSRP @ 15 MHz)
	Relative Accuracy (CINR):	P-SCH/S-SCH & RS	±1 dB

<b>LTE-LAA</b>	Measurement Modes	Quick Top N Reference Signal and Sync Signal (P-SCH/S-SCH)
	Data Modes	RS_RP, RS_RQ, RS_CINR, RS_TimeOffset, PSCH_RP, PSCH_RQ, PSCH_CINR, SSCH_RP, SSCH_RQ, SSCH_CINR
	Channel Bandwidths	20 MHz
	Max. Number of Channels	16
	Receive Modes	MISO
	Transmit Antenna	1, 2 (with path measurement)





	Configurations	
	Measurement Rates:	Sync Channel RS 1 Sig 160ms, 4 Sig 182ms, 8 Sig 205ms, 16 Sig 249ms
	Dynamic Range (CINR) @20 MHz	RS P-SCH/S -SCH -11 to +25 dB -10 to +18 dB
	Min. Detection Level:	RSRP -130 dBm (RSRP @ 20 MHz)
	Relative Accuracy (CINR):	RS RS ±2 dB (-10dB ~ +20dB)

<b>NB-IoT</b>	Measurement Modes		Top N NRS (Narrowband Reference Signal), NPSS (Narrowband Primary Synchronization Signal), NSSS (Narrowband Secondary Synchronization Signal) and Layer 3 Reporting, Blind Scan
	Data Modes		NRS - RP, RQ, RSSI, CINR, Timeoffset. NPSS - RP, RQ, RSSI, CINR. NSSS - RP, RQ, RSSI, CINR, Timeoffset
	Operation Mode		In-Band, Guard-band, Standalone
	Channel Bandwidths		180 kHz
	Measurement Rates		190 ms
	Dynamic Range	NRS_CINR	-10 to + 40 dB
	Min. Detection Level	NRS_RP	-138 dBm
	Relative Accuracy	NRS_CINR	±2
	Maximum Number of PCIs		16

<b>WCDMA</b>	Measurement Modes		Top N Pilot, Layer 3 Reporting, Blind Scan
	Data Modes		Io, Ec/Io, Aggregate Ec/Io, SIR, Rake Finger Count, Time Offset, Delay Spread
	Channel Bandwidths		200 kHz / 3.84 MHz
	Max. Number of Channels		24
	Measurement Rate		100/sec (High Speed Mode); 50/sec (High Dynamic Range Mode)
	Top N CPICH Dynamic Range	Ec/Io	-26 dB
	Min. Detection Level		-120 dBm (High Dynamic Range Mode)
	Relative Accuracy		±1 dB

<b>GSM</b>	Measurement Modes		Color Code, Layer 3 Reporting, Blind Scan
	Data Modes		BSIC, C/I, RSSI
	Channel Bandwidths		30 kHz / 200 kHz
	Measurement Rate		Up to 200 BSIC Decodes/sec
	Dynamic Range		+2 dB C/I
	Min. BSIC Detection Level		-110 dBm
	Relative Accuracy		±1 dB

<b>CDMA/EV-DO</b>	Measurement Modes	Top N PN, Blind Scan
	Data Modes	Ec, Io, Ec/Io, Aggregate Ec/Io, Pilot Delay, Delay Spread
	Channel Bandwidths	30 kHz / 1.25 MHz
	Max. Number of Channels	24
	Measurement Rate	CDMA: 25/sec; EV-DO: 18/sec
	Top N PN Dynamic Range      Ec/Io	CDMA: - 28 dB***; EV-DO: -18.5 dBm
	Min. PN Detection Level	CDMA: -130 dBm; EV-DO: -120 dBm
	Relative Accuracy	±1 dB

<b>Wi-Fi</b>	Measurement Modes	ORINOCO® USB-9100 (adapter is country specific)
	Radio Configuration	802.11a/b/g/n, 802.11a/b/g/n/ac
	Data Modes	Signal Strength, Noise Level, Channel Number, Channel Bandwidth, BSSID, Device Name, SSID, Security Protocol, 802.11 Media, Beacon Interval, Channel Utilization, Throughput
	Frequency Range	2.4 – 2.483 GHz; 5.15 – 5.85 GHz (subject to country regulations)
	Measurement Rates	9/sec (Typical); 5/sec (Typical) for 802.11ac

<b>P25</b>	Measurement Modes	Decode, RSSI
	Data Modes	SINR, RSSI, BER, Frame BER, Network ID, Auto Classification of Phase and Modulation Type
	Channel Bandwidths	12.5 KHz
	Measurement Rate	14 Decodes/sec (maximum) 7 Decodes/sec (typical) 100 RSSI/sec
	Dynamic Range	-1 dB minimum detection
	Relative accuracy      SINR Phase 1 C4FM and Phase 2      RSSI HDQPSK	±1 dB over 8 to 25 dB; ±2 dB over 3 to 8 dB, 25 to 30 dB ±1 dB over -118 to -10 dBm
	Adjacent channel rejection	49 dB



<b>DMR</b>	Measurement Modes	Decode, RSSI
	Data Modes	SINR, RSSI, BER, Frame BER,
	Channel Bandwidths	12.5 KHz
	Measurement Rate	14 Decodes/sec (maximum) 7 Decodes/sec (typical) 100 RSSI/sec
	Dynamic Range	-1 dB minimum detection
	Accuracy	SINR ±1 dB over 6 to 40 dB; ±2 dB over 3 to 6 dB RSSI ±1 dB over -118 to -10 dBm
	Adjacent channel rejection	49 dB

<b>TETRA</b>	Measurement Modes	Decode, RSSI
	Data Modes	SINR, RSSI, Frame BER, Color Code, MCC, MNC
	Channel Bandwidths	25 KHz
	Measurement Rate	6.5 Decodes/sec (maximum) 3.5 Decodes/sec (typical) 100 RSSI/sec
	Dynamic Range	-2 dB minimum detection
	Accuracy	SINR ±2 dB over +8 to +20 dB; ±3 dB over +4 to +8 dB RSSI ±1 dB over -118 to -10 dBm
	Adjacent channel rejection	20 dB

<b>Power Measurements</b>	<b>Measurement Modes</b>	
	RSSI	LTE, 5G NR WCDMA, GSM, NB-IoT CDMA, EV-DO
		11,050 ch/sec
		4,250 ch/sec
		8,500 ch/sec
	Dynamic Range	-120 to -20 dBm @ 30 kHz
	Absolute Accuracy	±1 dB (across Basic RF Input Power Range)
	<b>ENHANCED POWER SCAN (EPS™) MEASUREMENTS</b>	
	Channel Bandwidths	5 kHz to 20 MHz in 2.5 kHz Increments
	Measurement Rate	1,000 MHz/sec @ 5 MHz (Typical)
	Absolute Accuracy	±1 dB (across Basic RF Input Power Range)
	<b>SPECTRUM ANALYSIS MEASUREMENTS</b>	
	Measurement Range	> 90 dB
	Measurement Rate (Single Sweep)	>270 MHz/sec
	Accuracy	±1 dB (across Basic RF Input Power Range)
	<b>LTE POWER ANALYSIS MEASUREMENTS (Available for TD-LTE Only)</b>	
	Channel Bandwidths	1.4 / 3 / 5 / 10 / 15 / 20 MHz
	Measurement Rate	20 msec @ 5 MHz
Accuracy	±1 dB (across Basic RF Input Power Range)	



<b>RF Characteristics</b>	Measurement Modes	10 MHz – 6 GHz	
	Internally Generated Spurious Response	-110 dBm (Typical)	
	Conducted Local Oscillator	-75 dBm Max.	
	RF Operating Range	In-Band -15 dBm Max.	
	Desensitization	Adjacent Channel	>50 dB (CDMA/E V-DO)
		Adjacent Channel	>55 dB (All Other Technologies)
		Adjacent Channel	>65 dB
	Safe RF Input Range	≤ 10 dBm	
Frequency Accuracy	±0.05 ppm (GPS Locked); ± 0.1 ppm (GPS Unlocked)		
Intermodulation-free Dynamic Range	2 tone (level 2) @ -40 dBm, 6 GHz, -68 dBc (Typical), -12.6 dBm TOI; @ -25 dBm, 6 GHz, -70 dBc (Typical), 10 dBm TOI		

<b>GPS</b>	Measurement Modes	56 Channel Internal Receiver
	Vertical Position Accuracy	±2.5 meters
	Horizontal Accuracy (Altitude)	2x Vertical Position Accuracy
	Acquisition Time	Cold Start: <30 sec; Hot Start: <2 sec
	Sensitivity (Tracking)	> -150 dBm

<b>Physical</b>	Measurement Modes	Normal and Power Save	
	Maximum Power (+8 to +16 VDC)	18W; Power Save: 10W	
	Size	Without Battery Pack	7.6" D x 4.4" W x 1.55" H (192 mm D x 111.8 mm W x 39.4 mm H)
		With Battery Pack	10.1" D x 4.4" W x 2.1" H (257.6 mm D x 111.8 mm W x 53.1 mm H)
	Weight	Without Batteries	2.4 lb (1.1 kg)
		With Batteries	3.8 lb (1.7 kg)
	Temperature Range	Operating: 0°C to +50°C; Storage: - 40°C to +85°C	
	Host Data Communications Interface	USB 2.0, High Speed; Bluetooth	
	Data Storage	SD (32 GB) ( <b>IBflex Only</b> )	
	Antenna Ports Wi-Fi Communications Antenna	RF: SMA Female (50Ω); GPS: Male (50Ω) SMB	
	Safety (CE)	EN 62368-1: 2014	
	EMC	EN 301 489-1	
Shock and Vibration	MIL-STD-810G, SAE J1455		
RoHS	Compliant (6/6)		

## 10. Appendix B: Signal Analyzer Adapter

The Signal Analyzer Adapter is an optional hardware device for the SeeGull IBflex scanning receiver. It is designed to work with the scanner and the Signal Analyzer (SA) feature in SeeHawk Touch to address activities around network equipment, such as Distributed Antenna Systems (DAS) verification and commissioning.



The adapter features include:

- The hardware adapter holds the scanner enabling ease of use for connecting to the equipment for conducting the required measurements.
- The tablet with SeeHawk Touch collection software is also held by the adapter for ease of access of setups, displays and recording results.
- RF 1 connector has an extra 45 dB of attenuation built in for measuring higher level signals. (NOTE: This should be entered in the settings in the SA.)

Follow these steps to insert the scanner into the adapter:

1. Slide the scanner a few inches into the adapter, ensuring the top of the scanner is closest to the tablet holder.



2. The two levers on the sides should be held open, and then slide the scanner the rest of the way in (ensuring a firm connection to the adapter.)



3. The tablet can be placed in the table holder by spreading the edges apart.



NOTE: The Adapter comes with a one (1) year warranty.

## 11. Appendix C: NB-IoT Measurements

### 11.1. NB-IoT: Introduction

PCTEL is introducing a new measurement to quantify the KPI metrics of the NB-IoT network. This application note will discuss the new features of this measurement.

### 11.2. NB-IoT Physical Layer

The NB-IoT physical channels can be located as a stand-alone network or they could be part of a standard LTE network in Guard-band and In-Band spectrum. Below is a representation of these signals.

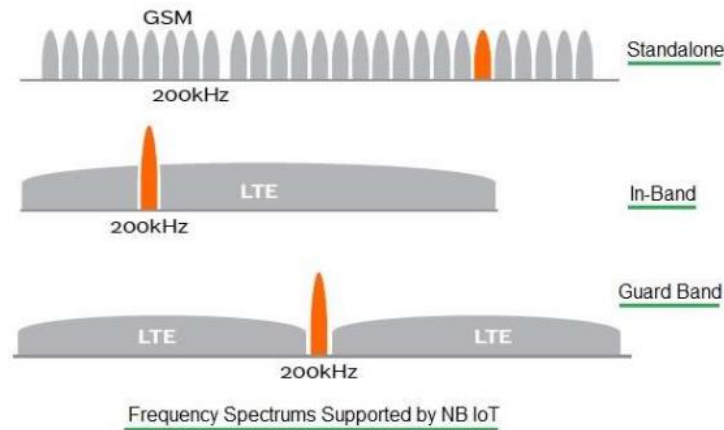

Figure 28 - NB-IoT

### 11.3. Top N NB-IoT Signal Measurement

Below is a list of key features of the new measurement.

- The NB-IoT carrier follows the 3GPP FD-LTE channel raster. It has a channel index value of 100 kHz. To align the NB-IoT signal with standard LTE the 3GPP standard introduces a *frequency offset* value from the channel raster. The values of the *offset* could be 0, +/-2.5 kHz and +/- 7.5 kHz. The scanner will calculate this value as explained below.
- The user must select the ‘operation mode’ to determine whether the network is stand-alone, Guard-band or In-Band.
- When the user selects the ‘stand-alone’ they must provide the *channel* or *frequency* of the NB-IoT network. In this mode the scanner calculates the *frequency offset* as zero.

- When the user selects the ‘In-Band’ operation mode the scanner calculates the frequency offset from the channel raster as shown in the second column of Table 1.
- When the user selects the ‘Guard-band’ mode the scanner needs additional information to calculate the frequency offset since there is a +/-7.5 kHz ambiguity as shown in column 3 of Table 2. In this mode the user has three choices for ‘frequency offset’:
  - ‘0’: The scanner automatically calculates the offset based on the table. In case of +/- 7.5 kHz ambiguity the scanner defaults to -7.5 kHz. In that case other modes should be used. See below.
  - ‘1’: The scanner inserts +7.5 kHz offset for the channel raster.
  - ‘2’: The scanner inserts -7.5 kHz offset for the channel raster.
- The scanner provides RP, RQ, CINR, Time offset values for primary and secondary synchronization channels as well as reference signal.
- In order to monitor the standard LTE network, the user can initiate a separate eTOPN LTE measurement.

LTE BW	Frequency Offset to 100kHz Raster	In-Band RB	In-Band EARFCN difference to Regular LTE
1.4MHz	-2.5kHz	N/A	N/A
	+2.5kHz	N/A	N/A
3MHz	+7.5kHz	12	9
	-7.5kHz	2	-9
5MHz	+7.5kHz	17, 22	9, 18
	-7.5kHz	2, 7	-18, -9
10MHz	-2.5kHz	30, 35, 40, 45	10, 19, 28, 37
	+2.5kHz	4, 9, 14, 19	-37, -28, -19, -10
15MHz	+7.5kHz	42, 47, 52, 57, 62, 67, 72	9, 18, 27, 36, 45, 54, 63
	-7.5kHz	2, 7, 12, 17, 22, 27, 32	-63, -54, -45, -36, -27, -18, -9
20MHz	-2.5kHz	55, 60, 65, 70, 75, 80, 85, 90, 95	10, 19, 28, 37, 46, 55, 64, 73, 82
	+2.5kHz	4, 9, 14, 19, 24, 29, 34, 39, 44,	-82, -73, -64, -55, -46, -37, -28, -19, -10

**Table 3: NB-IoT In Band**



LTE BW	Guard-Band EARFCN difference to Regular LTE	Frequency Offset to 100kHz Raster (kHz)
1.4MHz	N/A	N/A
	N/A	N/A
3MHz	N/A	N/A
	N/A	N/A
5MHz	24	+/- 7.5
	-24	-/+ 7.5
10MHz	46, 47, 48, 49	-2.5, 2.5, +/- 7.5, -2.5
	-46, -47, -48, -49	2.5, -2.5, -/+ 7.5, 2.5
15MHz	69, 70, 71, 72, 73, 74	+/- 7.5, -2.5, 2.5, +/- 7.5, -2.5, 2.5
	-69, -70, -71, -72, -73, -74	-/+ 7.5, 2.5, -2.5, -/+ 7.5, 2.5, -2.5
20MHz	91, 92, 93, 94, 95, 96, 97, 98, 99	-2.5, 2.5, +/- 7.5, -2.5, 2.5, +/- 7.5, -2.5, 2.5, +/- 7.5
	-91, -92, -93, -94, -95, -96, -97, -98, -99	2.5, -2.5, -/+ 7.5, 2.5, -2.5, -/+ 7.5, 2.5, -2.5, -/+ 7.5

**Table 4: NB-IoT Guard Band**



### **Trademarks**

© 2020 PCTEL, Inc. All rights reserved. PCTEL, SeeGull®, MXflex®, HBflex, IBflex®, and the PCTEL logo are trademarks of PCTEL, Inc.

Windows® is a registered trademark of Microsoft Corporation.

Android™ is a trademark of Google Inc.

### **Notices and Warranty Information**

The information in this document is subject to change without notice. PCTEL assumes no responsibility or makes no warranties for any errors that may appear in this document and disclaims any implied warranty of merchantability or fitness for a particular purpose. Further, PCTEL shall not be liable for incidental, consequential or other damages in connection with the use of this document.

### **Copyright Information**

No part of this document may be used or reproduced in any form or any means, in whole or in part, without prior written consent of PCTEL.

### **All Rights Reserved**

Copyright 1997-2020

**PCTEL, Inc.**

**Phone: +1 301 515 0036**