



±30 Gauss, High Performance, Low Cost 3-axis Magnetic Sensor

MMC3630KJ

FEATURES

- Fully integrated 3-axis magnetic sensor and electronic circuits requiring fewer external components
- Superior Dynamic Range and Accuracy:
 - ✓ ±30 G FSR with 16 bits operation
 - ✓ 1 mG per LSB resolution
 - ✓ 2 mG total RMS noise
 - ✓ Enables heading accuracy of ±1°
- Output data rate up to 600 Hz
- Ultra Small Low profile package
1.2x1.2x0.5 mm
- Degaussing with built-in SET/RESET function
 - ✓ Eliminates thermal variation induced offset error (Null field output)
 - ✓ Clears the residual magnetization resulting from strong external fields
- On-chip sensitivity compensation
- On-chip temperature sensor
- Motion_Detection and Data_Ready Interrupt
- Low power consumption
- 1 μA power down current
- I²C Slave, FAST (≤400 KHz) mode
- 1.8V single low power supply compatible
- Low to 1.2V I²C interface
- RoHS compliant
- P2P compatible with AK09911

APPLICATIONS

- Electronic Compass & GPS Navigation
- Position Sensing

DESCRIPTION

The MMC3630KJ is a complete 3-axis magnetic sensor with on-chip signal processing and integrated I²C bus. The device can be connected directly to a microprocessor, eliminating the need for A/D converters or timing resources. It can measure

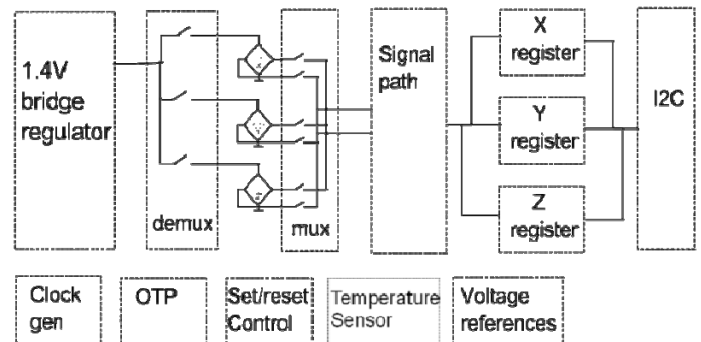

FUNCTIONAL BLOCK DIAGRAM

magnetic fields within the full scale range of ±30 Gauss (G), with 1 mG per LSB resolution at 16 bits operation mode and 2 mG total RMS noise level, enabling heading accuracy of ±1° in electronic compass applications. Contact MEMSIC for access to advanced calibration and tilt-compensation algorithms.

An integrated SET/RESET function provides for the elimination of error due to Null Field output change with temperature. In addition it clears the sensors of any residual magnetic polarization resulting from exposure to strong external magnets. The SET/RESET function can be performed for each measurement or periodically as the specific application requires.

The MMC3630KJ is packaged in an ultra-small low profile BGA package (1.2x 1.2 x 0.5 mm) and with an operating temperature range from -40 °C to +85 °C. The MMC3630KJ provides an I²C digital output with 400 KHz, fast mode operation.

Information furnished by MEMSIC is believed to be accurate and reliable. However, no responsibility is assumed by MEMSIC for its use, or for any infringements of patents or other rights of third parties which may result from its use. No license is granted by implication or otherwise under any patent or patent rights of MEMSIC.

©MEMSIC, Inc.
One Technology Drive, Suite 325, Andover, MA 01810, USA
Tel: +1 978 738 0900 Fax: +1 978 738 0196
www.memsic.com

SPECIFICATIONS (Measurements @ 25 °C, unless otherwise noted; VCAP=3 V, V_{DD}= 1.8 V unless otherwise specified)

Parameter	Conditions	Min	Typ	Max	Units
Field Range (Each Axis)	Total applied field	-30		+30	G
Supply Voltage	VCAP ¹	2.6	3	3.6	V
	VDD	1.62	1.8	3.6	V
VIO(I ² C interface and INT)		1.2	1.8	3.6	V
Supply Voltage rise time				5.0	ms
Supply Current ^{2,6} (7 measurements/second)	BW=00		240	300	μA
	BW=01		120	150	μA
	BW=10		60	80	μA
	BW=11		40	50	μA
Power Down Current ⁶			1.0	1.0	μA
Operating Temperature		-40		85	°C
Storage Temperature		-55		125	°C
Linearity Error ⁶ (Best fit straight line)	FS=±30 G H _{applied} =±15 G		0.3	0.5	%FS
Hysteresis ⁶	3 sweeps across ±30 G		0.03	0.2	%FS
Repeatability Error ⁶	3 sweeps across ±30 G		0.015	0.1	%FS
Alignment Error			±1.0	±3.0	Degrees
Transverse Sensitivity			±2.0	±5.0	%
Total RMS Noise ⁶	BW=00		2.0	4.0	mG
	BW=01		2.0	4.0	mG
	BW=10		3.0	5.0	mG
	BW=11		4.0	5.0	mG
Output resolution			16		Bits
Max Output data rate	BW=00		100		Hz
	BW=01		200		Hz
	BW=10		400		Hz
	BW=11		600		Hz
Heading accuracy ³			±1.0		Degrees
Sensitivity ^{4,7}	±30 G	-5		+5	%
			1024		counts/G
Sensitivity Change Over Temperature ⁶	-40~85 °C Delta from 25 °C ±30 G		±5		%
Null Field Output ⁷		-0.5		+0.5	G
			32768		Counts
Temperature Sensor Output ⁷		0.6	0.8	1.0	°C/Count
Disturbing Field ⁵			36		G
Maximum Exposed Field				10,000	G

¹ Not applicable when using internal charge pump circuitry

² Supply current is proportional to how many measurements performed per second

³ MEMSIC product enables users to utilize heading accuracy to be 1.0 degree typical when using MEMSIC's proprietary software or algorithm

⁴ Sensitivity of the orthogonal axes is analytically derived from raw data and is subsequently processed by MEMSIC software drivers

⁵ This is the magnitude of external field that can be tolerated without changing the sensor characteristics. If the disturbing field is exceeded, a SET/RESET operation is required to restore proper sensor operation

⁶ Based on 3lots characterization result.

⁷ Based on shipment test result.

DIGITER INTERFACE (VIO=1.8V)

Symbol	Parameter (Units)	Minimum	Typical	Maximum
V _{IH}	High Level Input Voltage (Volts)	0.7*VIO		
V _{IL}	Low Level Input Voltage (Volts)			0.3*VIO
V _{HYS}	Hysteresis of Schmitt Trigger Input (Volts)	0.1		
I _{IL}	Input Leakage, All Inputs (uA)	-10		10
V _{OH}	High Level Output Voltage (Volts)	0.8*VIO		
V _{OL}	Low Level Output Voltage (Volts)			0.2*VIO

I²C INTERFACE I/O CHARACTERISTICS (V_{IO}=1.8 V)

Parameter	Symbol	Test Condition	Min.	Typ.	Max.	Unit
Logic Input Low Level	V _{IL}		-0.5		0.3* V _{IO}	V
Logic Input High Level	V _{IH}		0.7*V _{IO}		V _{IO}	V
Hysteresis of Schmitt input	V _{hys}		0.2			V
Logic Output Low Level	V _{OL}				0.4	V
Input Leakage Current	I _i	0.1V _{IO} <V _{in} <0.9V _{IO}	-10		10	μA
SCL Clock Frequency	f _{SCL}		0		400	kHz
START Hold Time	t _{HD:STA}		0.6			μS
START Setup Time	t _{SU:STA}		0.6			μS
LOW period of SCL	t _{LOW}		1.3			μS
HIGH period of SCL	t _{HIGH}		0.6			μS
Data Hold Time	t _{HD:DAT}		0		0.9	μS
Data Setup Time	t _{SU:DAT}		0.1			μS
Rise Time	t _r	From V _{IL} to V _{IH}			0.3	μS
Fall Time	t _f	From V _{IH} to V _{IL}			0.3	μS
Bus Free Time Between STOP and START	t _{BUF}		1.3			μS
STOP Setup Time	t _{SU:STO}		0.6			μS

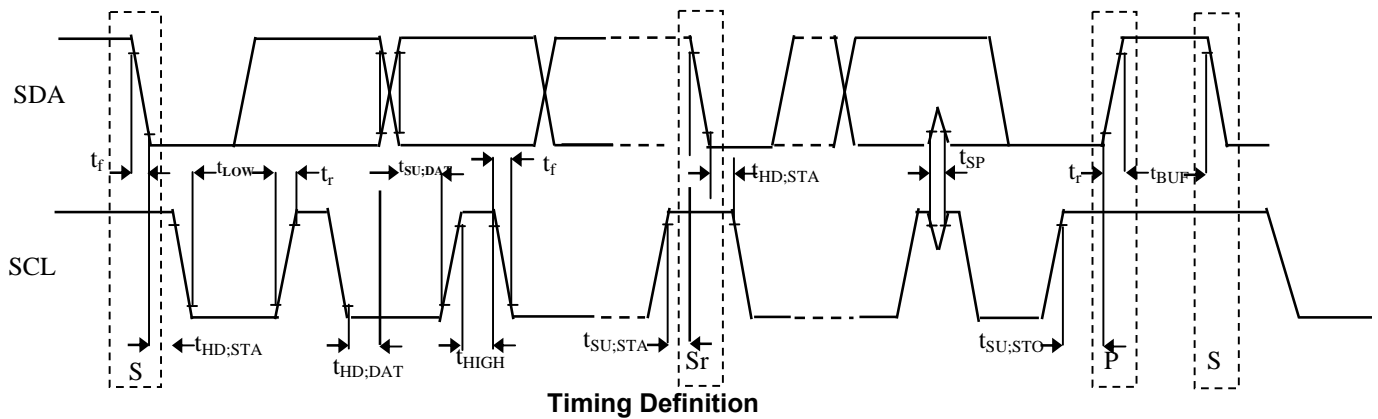

ABSOLUTE MAXIMUM RATINGS*

Supply Voltage	-0.5 to +5 V
Storage Temperature	-55 °C to +125 °C
Maximum Exposed Field	10000 G

Note: Stresses above those listed under Absolute Maximum Ratings may cause permanent damage to the device. This is a stress rating only; the functional operation of the device at these or any other conditions above those indicated in the operational sections of this specification is not implied. Exposure to absolute maximum rating conditions for extended periods may affect the device's reliability.

Pin Description: BGA Package

Pin	Name	Description	I/O
A1	VCAP	Power Supply for SET/RESET Coil	P
A2	NC	Not Connected	NC
A3	NC	Not Connected	NC
B1	VSA	Connect to Ground	P
B3	SCL	Serial Clock Line for I ² C bus	I
C1	VDD	Power Supply	P
C2	INT	Interrupt Output	O
C3	SDA	Serial Data Line for I ² C bus	I/O

All parts are shipped in tape and reel packaging with 9000 pcs per 13" reel or 3000pcs per 7" reel.

Caution:

This is an Electro-static Discharge (ESD) sensitive device.

Ordering Guide:

MMC3630KJ

Package type:	
Code	Type
J	BGA8 RoHS compliant
Performance Grade:	
Code	Performance Grade
K	Temp compensated
I ² C address	
Code	7bits address
0	0110000

Marking illustration:

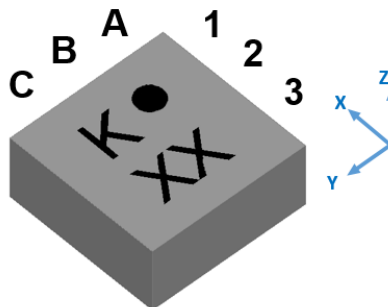

Note: Coordinates shown above indicate polarity after a SET operation.

“Number” (top-left character) is used to differentiate between similar devices. The black dot marks the location of pin one (1). The 2nd line represents the device's Lot Number.

THEORY OF OPERATION

The Anisotropic Magneto-Resistive (AMR) sensors are special resistors made of permalloy thin film deposited on a silicon wafer. During manufacturing, a strong magnetic field is applied to the film to orient its magnetic domains in the same direction, establishing a magnetization vector. Subsequently, an external magnetic field applied perpendicularly to the sides of the film causes the magnetization to rotate and change angle. This effect causes the film's resistance to vary with the intensity of the applied magnetic field. The MEMSIC AMR sensor is incorporated into a Wheatstone bridge configuration to maximize Signal to Noise ratio. A change in magnetic field produces a proportional change in differential voltage across the Wheatstone bridge.

However, the influence of a strong magnetic field (more than 36 G) in any direction could upset, or flip, the polarity of the film, thus changing the sensor characteristics. A strong restoring magnetic field must be applied momentarily to restore, or set, the sensor characteristics. The MEMSIC magnetic sensor has an on-chip magnetically coupled strap: a SET/RESET strap pulsed with a high current, to provide the restoring magnetic field.

EXTERNAL CIRCUITRY CONNECTION

The MMC3630KJ was designed for flexible power connections to support existing and new designs. It can operate from a single 1.62V to 3.6V supply or from dual supplies using a 1.62V to 3.6V ASIC supply and a 2.6V to 3.6V sensor supply. When using a single supply it is necessary to enable the internal charge pump. This pump charges the capacitor connected to VCAP, where energy is stored for SET/RESET operations. The circuit connection diagrams below illustrate power supply connection options.

The circuit connection diagrams below illustrate power supply connection options.

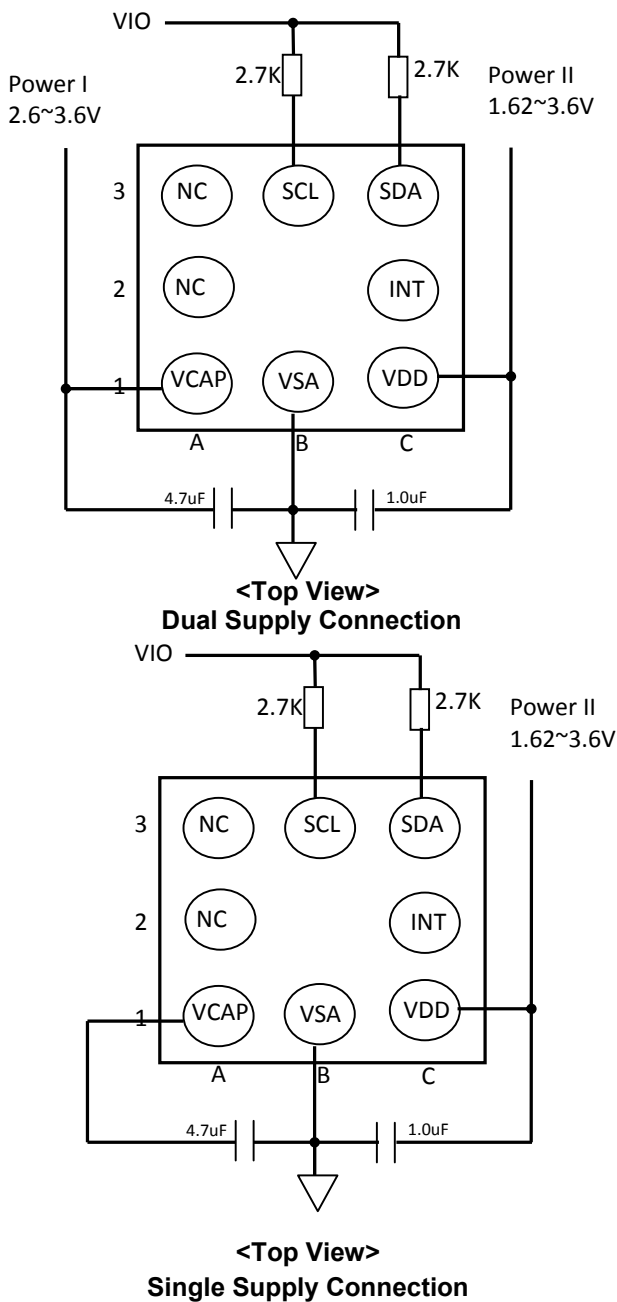

See Table below for operating in different supply modes

Power Supply Options	Dual Supply	Single Supply
Power I	2.6V ~3.6V	NA
Power II	1.62V~3.6V	1.62V~3.6V
VCAP	Connected to Power I	Connected to Ground through a 4.7 μ F Cap
Charge Pump	Disabled	Enabled; turn on before SET/RESET
Refill Cap ¹	0	Write "1" before SET/RESET

¹ Register bits in "Control Register 0"

PIN DESCRIPTIONS

VCAP – This is the supply input for SET/RESET coil. MEMSIC recommends a minimum bypass capacitor of 2 μ F placed in close proximity to the VCAP pin. The total bypass capacitance connected to VCAP line, including the 2 μ F capacitor, should not be smaller than 4.7 μ F.

VSA – This is the ground pin for the magnetic sensor.

SDA – This pin is the I²C serial data line, and operates in FAST (400 KHz) mode.

SCL– This pin is the I²C serial clock line, and operates in FAST (400 KHz) mode.

VDD–This pin is the power supply of the analog and digital parts of ASIC.

INT – Interrupt output. High effective. This pin is held as hi-Z until an interrupt function is enabled.

HARDWARE DESIGN CONSIDERATION

- ✓ Provide adequate separation distance to devices that contain permanent magnets or generate magnetic fields (e.g. speakers, coils, inductors) The combined magnetic field to be measured and interference magnetic field should be less than the full scale range of the MMC3630KJ (± 30 G).
- ✓ Provide adequate separation distance to current carrying traces. Do not route current carrying traces under the sensor or on the other side of the PCB opposite the device.
- ✓ Do not cover the sensor with magnetized material or material that may become magnetized, (e.g., shield box, LCD, battery, iron bearing material).
- ✓ Do not place the device opposite magnetized material or material that may become magnetized located on the other side of the PCB.

Please refer to MEMSIC application note: AN-200-20-0001 (MEMSIC Magnetic Sensor Hardware Design Layout Guideline for Electronic Device).

POWER CONSUMPTION

The power consumed by the device is proportional to the number of measurements taken per second. For example, when $BW<1:0>=00$, that is, 16-bit mode with 10 ms per measurement, MMC3630KJ consumes 240 μA (typical) at 1.8 V with 7 measurements per second. If only 2 measurements are performed per second, the current will be $240 \times 2/7 = 68.6 \mu\text{A}$.

I²C INTERFACE DESCRIPTION

A slave mode I²C circuit has been implemented into the MEMSIC magnetic sensor as a standard interface for customer applications. The A/D converter functionality have been added to the MEMSIC sensor, thereby increasing ease-of-use, and lowering power consumption, footprint and total solution cost.

The I²C (or Inter IC bus) is an industry standard bi-directional two-wire interface bus. A master I²C device can operate READ/WRITE controls to 128 devices by device addressing. The MEMSIC magnetic sensor operates only in a slave mode, i.e. only responding to calls by a master device. Can operate READ/WRITE controls to 128 devices by device addressing. The MEMSIC magnetic sensor operates only in a slave mode, i.e. only responding to calls by a master device.

I²C BUS CHARACTERISTICS

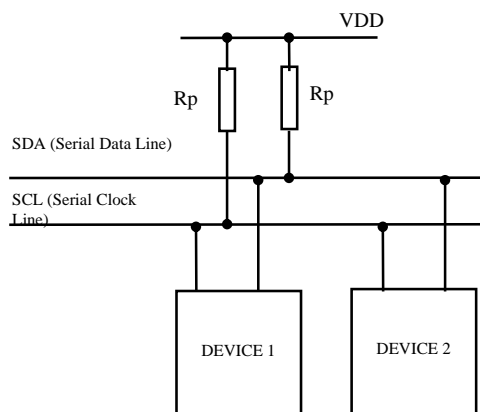

The two wires in the I²C bus are called SDA (serial data line) and SCL (serial clock line). In order for a data transfer to start, the bus has to be free, which is defined by both wires in a HIGH output state. Due to the open-drain/pull-up resistor structure and wired Boolean "AND" operation, any device on the bus can pull lines low and overwrite a HIGH signal. The data on the SDA line has to be stable during the HIGH period of the SCL line. In other words, valid data can only change when the SCL line is LOW.

Note: Rp selection guide: 4.7Kohm for a short I²C bus length (less than 10 cm), and 10Kohm for a bus length less than 5 cm.

REGISTER MAP

Register Name	Address	Description
Xout Low	00H	Xout LSB
Xout High	01H	Xout MSB
Yout Low	02H	Yout LSB
Yout High	03H	Yout MSB
Zout Low	04H	Zout LSB
Zout High	05H	Zout MSB
Temperature	06H	Temperature output
Status	07H	Device status
Internal control 0	08H	Control register 0
Internal control 1	09H	Control register 1
Internal control 2	0AH	Control register 2
X Threshold	0BH	Motion detection threshold of X
Y Threshold	0CH	Motion detection threshold of Y
Z Threshold	0DH	Motion detection threshold of Z
Product ID 1	2FH	Product ID

Register Details

Xout High, Xout Low

Xout Low	7	6	5	4	3	2	1	0
Addr: 00H	Xout[7:0]							
Mode	R							

Xout High	7	6	5	4	3	2	1	0
Addr: 01H	Xout[15:8]							
Mode	R							

X-axis output, unsigned format.

Yout High, Yout Low

Yout Low	7	6	5	4	3	2	1	0
Addr: 02H	Yout[7:0]							
Mode	R							

Yout High	7	6	5	4	3	2	1	0
Addr: 03H	Yout[15:8]							
Mode	R							

Y-axis output, unsigned format.

Zout High, Zout Low

Zout Low	7	6	5	4	3	2	1	0
Addr: 04H	Zout[7:0]							
Mode	R							

Zout High	7	6	5	4	3	2	1	0
Addr: 05H	Zout[15:8]							
Mode	R							

Z-axis output, unsigned format.

Temperature Out

Temperature	7	6	5	4	3	2	1	0
Addr: 06H	Tout[7:0]							
Mode	R							

Temperature output, unsigned format. The range is -75~125°C, about 0.8°C/LSB, 00000000 stands for -75°C.

Status

Device Status	7	6	5	4	3	2	1	0
Addr: 07H	Reserved			OTP_Rd_Done	Pump On	Motion Detected	Meas_T_Done	Meas_M_Done
Reset Value	0	0	0	0	0	0	0	0
Mode	R/W							

Bit Name	Description
Meas_M_Done	Indicates a measurement event of magnetic field is completed. This bit should be checked before reading the output. When the new measurement command is occurred , this bit turns to "0" . When the measurement is finished, this bit will remain "1" till next measurement. Writing 1 into this bit will clear the corresponding interrupt.
Meas_T_Done	Indicates a measurement event of temperature is completed. When the new measurement command is occurred , this bit turns to "0" . When the measurement is finished, this bit will remain "1" till next measurement. Writing 1 into this bit will clear the corresponding interrupt.
Motion Detected	Indicates a motion is detected. Writing 1 into this bit will clear the corresponding interrupt.
Pump On	Indicates the charge pump status, after Refill Cap command, the charge pump will start running, and this bit will stays high, it will be reset low after the cap reaches its target voltage and the charge pump is shut off.
OTP_Rd_Done	Indicates the chip was able to successfully read its memory.

Internal Control 0

Control Register 0	7	6	5	4	3	2	1	0
Addr: 08H	Test_Pin_Sel	OTP Read	Refill Cap	Reset	Set	Start_MD_T	TM_T	TM_M
Reset Value	0	0	0	0	0	0	0	0
Mode	W	W	W	W	W	W	W	W

Bit Name	Description
TM_M	Take magnetic field measurement, set '1' will initiate measurement. This bit will be automatically reset to 0.
TM_T	Take Temperature measurement, set '1' will initiate measurement. This bit will be automatically reset to 0. Need work respectively with TM_M.
Start_MDT	Start the motion detector. Set "1" will perform an initial magnetic measurement and use this number as the baseline, then the magnetic measurements are done periodically, and compare the new data with the baseline. If the difference exceeds the threshold, the bit "Motion Detected" in 07H is set to "1". The frequency of the periodic measurements is set by CM_Freq in 0AH, and the thresholds are set in 0BH, 0CH, and 0DH. Once a motion is detected, this bit is reset to 0.
Set	Writing "1" will SET the sensor by passing a large current through SET/RESET Coil
Reset	Writing "1" will RESET the sensor by passing a large current through SET/RESET Coil in a reversed direction
Refill Cap	Writing "1" will recharge the capacitor at VCAP pin, it is requested to be issued before SET/RESET command. When external power supply is adopted, this bit is reserved, write "0".
OTP Read	Writing "1" will let the device to read the OTP data again. This bit will be automatically reset to 0.
Test_Pin_Sel	Factory-used bit.

Internal Control 1

Control Register 1	7	6	5	4	3	2	1	0
Addr: 09H	SW_RST	OTP_BL_SEL1	OTP_BL_SEL0	Z-inhibit	Y-inhibit	X-inhibit	BW1	BW0
Reset Value	0	0	0	0	0	0	0	0
Mode	W	W	W	W	W	W	W	W

Bit Name	Description																									
BW0 & BW1	Output resolution																									
	<table border="1"> <thead> <tr> <th>BW1</th> <th>BW0</th> <th>Output Resolution</th> <th>Measurement Time</th> <th>ODR</th> </tr> </thead> <tbody> <tr> <td>0</td> <td>0</td> <td>16 bits</td> <td>10 ms</td> <td>100Hz</td> </tr> <tr> <td>0</td> <td>1</td> <td>16 bits</td> <td>5ms</td> <td>200Hz</td> </tr> <tr> <td>1</td> <td>0</td> <td>16 bits</td> <td>2.5 ms</td> <td>400Hz</td> </tr> <tr> <td>1</td> <td>1</td> <td>16 bits</td> <td>1.6ms</td> <td>600Hz</td> </tr> </tbody> </table>	BW1	BW0	Output Resolution	Measurement Time	ODR	0	0	16 bits	10 ms	100Hz	0	1	16 bits	5ms	200Hz	1	0	16 bits	2.5 ms	400Hz	1	1	16 bits	1.6ms	600Hz
	BW1	BW0	Output Resolution	Measurement Time	ODR																					
	0	0	16 bits	10 ms	100Hz																					
	0	1	16 bits	5ms	200Hz																					
1	0	16 bits	2.5 ms	400Hz																						
1	1	16 bits	1.6ms	600Hz																						
Note: X/Y/Z channel measurements are taken sequentially. Delay Time among those measurements is 1/3 of the Measurement Time defined in the table.																										
X-inhibit	Writing "1" will disable this channel, and reduce Measurement Time and total charge per measurement.																									
Y-inhibit																										
Z-inhibit																										
OTP_BL_SEL0 & OTP_BL_SEL1	Factory-use bits.																									
SW_RST	Writing "1" will cause the part to reset, similar to power-up. It will clear all registers and also re-read OTP as part of its startup routine. The power on time is 5mS.																									

Internal Control 2

Control Register 2	7	6	5	4	3	2	1	0
Addr: 0AH	ULP_SEL	INT_Meas_Done_EN	INT_MDT_EN	Force_Vddl_Stby	CM_Freq3	CM_Freq2	CM_Freq1	CM_Freq0
Reset Value	0	0	0	0	0	0	0	0
Mode	W	W	W	W	W	W	W	W

Bit Name	Description																										
CM_Freq[3:0]	These bits determine how often the chip will take measurements in Continuous Measurement Mode. The frequency is based on the assumption that BW[1:0] = 00.																										
	<table border="1"> <thead> <tr> <th>CM_Freq [3:0]</th> <th>Frequency</th> </tr> </thead> <tbody> <tr> <td>0000</td> <td>Continuous Measurement Mode is off. Motion detector does not work in this case.</td> </tr> <tr> <td>0001</td> <td>14 Hz</td> </tr> <tr> <td>0010</td> <td>5 Hz</td> </tr> <tr> <td>0011</td> <td>2.2 Hz</td> </tr> <tr> <td>0100</td> <td>1 Hz</td> </tr> <tr> <td>0101</td> <td>1/2 Hz</td> </tr> <tr> <td>0110</td> <td>1/4 Hz</td> </tr> <tr> <td>0111</td> <td>1/8 Hz</td> </tr> <tr> <td>1000</td> <td>1/16 Hz</td> </tr> <tr> <td>1001</td> <td>1/32 Hz</td> </tr> <tr> <td>1010</td> <td>1/64 Hz</td> </tr> <tr> <td>1011 and above</td> <td>Reserved and not used.</td> </tr> </tbody> </table>	CM_Freq [3:0]	Frequency	0000	Continuous Measurement Mode is off. Motion detector does not work in this case.	0001	14 Hz	0010	5 Hz	0011	2.2 Hz	0100	1 Hz	0101	1/2 Hz	0110	1/4 Hz	0111	1/8 Hz	1000	1/16 Hz	1001	1/32 Hz	1010	1/64 Hz	1011 and above	Reserved and not used.
	CM_Freq [3:0]	Frequency																									
	0000	Continuous Measurement Mode is off. Motion detector does not work in this case.																									
	0001	14 Hz																									
	0010	5 Hz																									
	0011	2.2 Hz																									
	0100	1 Hz																									
	0101	1/2 Hz																									
	0110	1/4 Hz																									
	0111	1/8 Hz																									
	1000	1/16 Hz																									
	1001	1/32 Hz																									
1010	1/64 Hz																										
1011 and above	Reserved and not used.																										
Force_Vddl_Stby	Factory-use bit.																										
INT_MDT_EN	Writing "1" will enable the interrupt when a motion is detected by the internal motion detector.																										
INT_Meas_Done_EN	Writing "1" will enable the interrupt when a magnetic or temperature measurement even is completed.																										
ULP_SEL	Factory-use bit.																										

X Threshold

X Threshold	7	6	5	4	3	2	1	0
Addr: 0BH	X_Mag_TH[7:0]							
Reset Value	0							
Mode	W	W	W	W	W	W	W	W

The threshold magnetic field of the motion detector in the x direction, with unsigned format. The step size is 4mG, and maximum threshold is 1G.

Y Threshold

Y Threshold	7	6	5	4	3	2	1	0
Addr: 0CH	Y_Mag_TH[7:0]							
Reset Value	0							
Mode	W	W	W	W	W	W	W	W

The threshold magnetic field of the motion detector in the y direction, with unsigned format. The step size is 4mG, and maximum threshold is 1G.

Z Threshold

Z Threshold	7	6	5	4	3	2	1	0
Addr: 0DH	Z_Mag_TH[7:0]							
Reset Value	0							
Mode	W	W	W	W	W	W	W	W

The threshold magnetic field of the motion detector in the z direction, with unsigned format. The step size is 4mG, and maximum threshold is 1G.

Product ID 1

Product ID 1	7	6	5	4	3	2	1	0
Addr: 2FH	Product ID1[7:0]							
Reset Value	0	0	0	0	1	0	1	0
Mode	R	R	R	R	R	R	R	R

DATA TRANSFER

A data transfer is started with a “START” condition and ended with a “STOP” condition. A “START” condition is defined by a HIGH to LOW transition on the SDA

line while SCL line is HIGH. A “STOP” condition is defined by a LOW to HIGH transition on the SDA line while the SCL line is held HIGH. All data transfer in I²C system are 8-bits long. Each byte has to be followed

by an acknowledge bit. Each data transfer involves a total of 9 clock cycles. Data is transferred starting with the most significant bit (MSB).

After a START condition, the master device calls a specific slave device by sending its 7-bit address with the 8th bit (LSB) indicating that either a READ or WRITE operation will follow, [1] for READ and [0] for WRITE. The MEMSIC device 7-bit device address is [0110000] where the three LSB's are pre-programmed into the MMC3630KJ by the factory and they are indicated on the package as shown in the previous section “Package Marking Illustration”.

A total of 8 different addresses can be pre-programmed into MEMSIC device by the factory. This variation of I²C address avoids a potential address conflict, either by ICs from other manufacturers or by other MEMSIC devices on the same bus

The initial addressing of the slave is always followed by the master writing the number of the slave register to be read or written, so this initial addressing always indicates a WRITE operation by sending [0110000]. After being addressed, the MEMSIC device being called should respond by an “Acknowledge” signal by pulling SDA line LOW. Subsequent communication bytes can either be

- a) The data to be written to the device register, or
- b) Another START condition followed by the device address indicating a READ operation [0110001], and then the master reads the register data.

Multiple data bytes can be written or read to numerically sequential registers without the need of another START condition. Data transfer is terminated by a STOP condition or another START condition. Two detailed examples of communicating with the MEMSIC device are listed below for the actions of acquiring a magnetic field measurement and magnetizing the sensor.

EXAMPLE MEASUREMENT

1st cycle: A START condition is established by the Master Device followed by a call to the slave address [0110000] with the eighth bit held low to indicate a

WRITE request. Note: [xxx] is determined by factory programming and a total of 8 different addresses are available.

2nd cycle: After an acknowledge signal is received by the master device (MEMSIC device pulls SDA line low during 9th SCL pulse), the master device sends the address of Control Register 0 or [00001000] as the target register to be written. The MEMSIC device should acknowledge receipt of the address (9th SCL pulse, SCL pulled low).

3rd cycle: The Master device writes to the Internal Control Register 0 the code [00000001] (TM_M high) to initiate data acquisition. The MEMSIC device should send an Acknowledge and internally initiate a measurement (collect x, y and z data). A STOP condition indicates the end of the write operation.

4th cycle: The Master device sends a START command followed by the MEMSIC device's seven bit address, and finally the eighth bit set low to indicate a WRITE. An Acknowledge should be send by the MEMSIC device in response.

5th cycle: The Master device sends the MEMSIC device's Status Register [00000111] as the address to read.

6th cycle: The Master device sends a START command followed by the MEMSIC device's seven bit address, and finally the eighth bit set high to indicate a READ. An Acknowledge should be send by the MEMSIC device in response.

7th cycle: The Master device cycles the SCL line. This causes the Status Register data to appear on SDA line. Continuously read the Status Register until the Meas_M_Done bit (bit 0) is set to '1'. or check INT pin status. This indicates that data for the x, y, and z sensors is available to be read.

8th cycle: The Master device sends a START command followed by the MEMSIC device's seven bit address, and finally the eighth bit set low to indicate a WRITE. An Acknowledge should be send by the MEMSIC device in response.

9th cycle: The Master device sends a [00000000] (Xout LSB register address) as the register address to read.

10th cycle: The Master device calls the MEMSIC device's address with a READ (8th SCL cycle SDA line high). An Acknowledge should be send by the MEMSIC device in response.

11th cycle: Master device continues to cycle the SCL line, and each consecutive byte of data from the X, Y and Z registers should appear on the SDA line. The internal memory address pointer automatically moves to the next byte. The Master device acknowledges each. Thus:

12th cycle: LSB of X channel.

13th cycle: MSB of X channel.

14th cycle: LSB of Y channel.

15th cycle: MSB of Y channel.

16th cycle: LSB of Z channel.

17th cycle: MSB of Z channel.

Master ends communications by NOT sending an 'Acknowledge' and also follows with a 'STOP' command.

EXAMPLE OF SET WHEN USING DUAL SUPPLY

1st cycle: A START condition is established by the Master Device followed by a call to the slave address [0110000] with the eighth bit held low to indicate a WRITE request. Note: [xxx] is determined by factory programming and a total of 8 different addresses are available.

2nd cycle: After an acknowledge signal is received by the master device (The MEMSIC device pulls the SDA line low during the 9th SCL pulse), the master device sends [00001000] as the target address (Internal Control Register 0). The MEMSIC device should acknowledge receipt of the address (9th SCL pulse).

3rd cycle: The Master device writes to the MEMSIC device's Internal Control 0 register the code [00001000] (SET bit) to initiate a SET action. The MEMSIC device should send an Acknowledge.

EXAMPLE OF SET WHEN USING SINGLE SUPPLY

1st cycle: A START condition is established by the Master Device followed by a call to the slave address [0110000] with the eighth bit held low to indicate a WRITE request. Note: [xxx] is determined by factory programming and a total of 8 different addresses are available.

2nd cycle: After an acknowledge signal is received by the master device (The MEMSIC device pulls the SDA line low during the 9th SCL pulse), the master device sends [00001000] as the target address (Internal Control Register 0). The MEMSIC device should acknowledge receipt of the address (9th SCL pulse).

3rd cycle: The Master device writes to the MEMSIC device's Internal Control Register 0 the code [00100000] (Refill Cap) to prepare for SET action.*

A minimum of 50ms wait should be provided to allow the MEMSIC device to finish its preparation for the SET action.

4th cycle: The Master device writes to the MEMSIC device's Internal Control 0 register the code [00001000] (SET bit) to initiate a SET action. The MEMSIC device should send an Acknowledge.

EXAMPLE OF RESET WHEN USING DUAL SUPPLY

1st cycle: A START condition is established by the Master Device followed by a call to the slave address [0110000] with the eighth bit held low to indicate a WRITE request. Note: [xxx] is determined by factory programming and a total of 8 different addresses are available.

2nd cycle: After an acknowledge signal is received by the master device (The MEMSIC device pulls the SDA line low during the 9th SCL pulse), the master device sends [00001000] as the target address (Internal Control Register 0). The MEMSIC device should acknowledge receipt of the address (9th SCL pulse).

3rd cycle: The Master device writes to the MEMSIC device's Internal Control 0 register the code [00010000] (RESET bit) to initiate a RESET action. The MEMSIC device should send an Acknowledge.

At this point, the MEMSIC AMR sensors have been conditioned for optimum performance and data measurements can commence.

EXAMPLE OF RESET WHEN USING SINGLE SUPPLY

1st cycle: A START condition is established by the Master Device followed by a call to the slave address [0110000] with the eighth bit held low to indicate a WRITE request. Note: [xxx] is determined by factory programming and a total of 8 different addresses are available.

2nd cycle: After an acknowledge signal is received by the master device (The MEMSIC device pulls the SDA line low during the 9th SCL pulse), the master device sends [00001000] as the target address (Internal Control Register 0). The MEMSIC device should acknowledge receipt of the address (9th SCL pulse).

3rd cycle: The Master device writes to the MEMSIC device's Internal Control Register 0 the code [00100000] (Refill Cap) to prepare for RESET action.

A minimum of 50ms wait should be provided to allow the MEMSIC device to finish its preparation for the RESET action.

4th cycle: The Master device writes to the MEMSIC device's Internal Control 0 register the code [00010000] (RESET bit) to initiate a RESET action. The MEMSIC device should send an Acknowledge.

At this point, the MEMSIC AMR sensors have been conditioned for optimum performance and data measurements can commence.

Note:

- The RESET action can be skipped for most applications

USING SET AND RESET TO REMOVE BRIDGE OFFSET

The integrated SET and RESET functions of the MMC3630KJ enables the user to remove the error associated with bridge Offset change as a function of temperature, thereby enabling more precise heading measurements over a wider temperature than competitive technologies. The SET and RESET functions effectively alternately flip the magnetic sensing polarity of the sensing elements of the device.

- 1) The most accurate magnetic field measurements can be obtained by using the protocol described as follows: Perform SET. This sets the internal magnetization of the sensing resistors in the direction of the SET field.
- 2) Perform MEASUREMENT. This measurement will contain not only the sensors response to the external magnetic field, H, but also the Offset; in other words,
Output1 = +H + Offset.





- 3) Perform RESET. This resets the internal magnetization of the sensing resistors in the direction of the RESET field, which is opposite to the SET field (180° opposed).
- 4) Perform MEASUREMENT. This measurement will contain both the sensors response to the external field and also the Offset. In other words,
Output2 = -H + Offset.
- 5) Finally, calculate H by subtracting the two measurements and dividing by 2. This procedure effectively eliminates the Offset from the measurement and therefore any changes in the Offset over temperature.

Note:

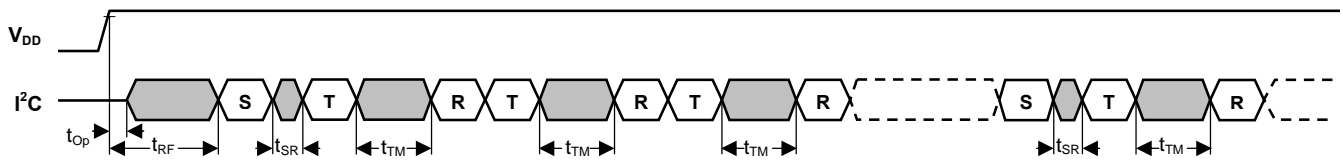
- To calculate and store the offset; add the two measurements and divide by 2. This calculated offset value can be subtracted from subsequent measurements to obtain H directly from each measurement.

OPERATING TIMING



-  SET/RESET
-  Take Measurement
-  Read data
-  Repeat T & R
-  Wait the device to be ready for next operation

Operating Timing Diagram

Parameter	Symbol	Min.	Max.	Unit
Time to operate device after V_{DD} valid	t_{Op}	5		ms
Time from Cap Refill to SET/RESET (dual power supply)	t_{RF}	1		ms
Time from Cap Refill to SET/RESET (single power supply)	t_{RF}	50		ms
Minimum time interval between SET or RESET	t_{SR}	1		ms
Wait time to complete measurement	t_{TM} BW=00	10		ms
	t_{TM} BW=01	5		ms
	t_{TM} BW=10	2.5		ms
	t_{TM} BW=11	1.6		ms

SOLDERING RECOMMENDATIONS

MEMSIC magnetic sensor is capable of withstanding an MSL3 / 260 °C solder reflow. Following is the reflow profile:

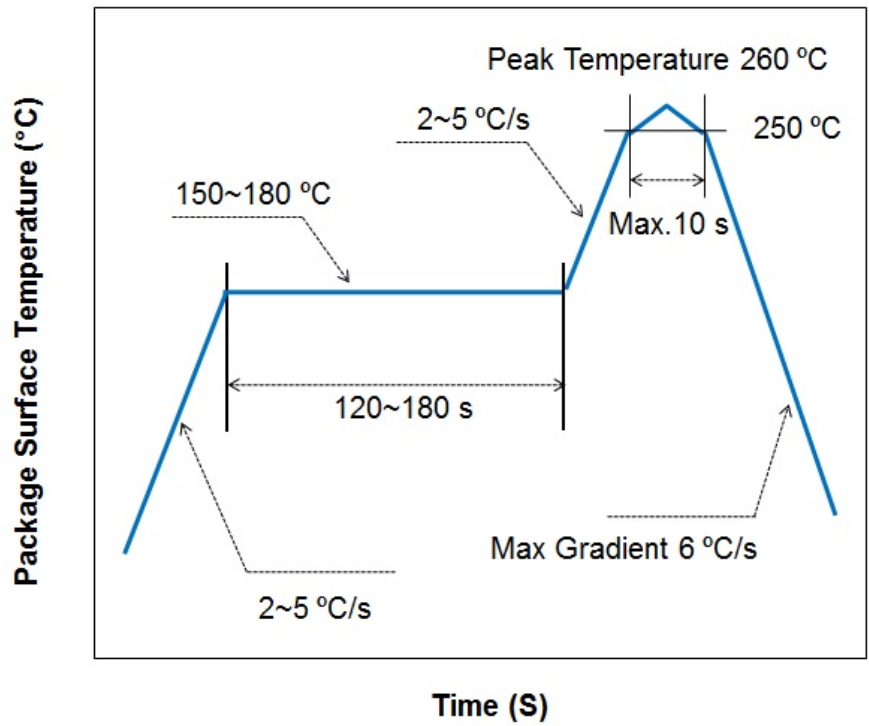

Note:

- The second reflow cycle should be applied after device has cooled down to 25 °C (room temperature)
- This is the reflow profile for Pb free process
- The peak temperature on the sensor surface should be limited under 260 °C for 10 seconds.
- Solder paste's reflow recommendation should be followed to get the best SMT quality.

If the part is mounted manually, please ensure the temperature could not exceed 260 °C for 10 seconds.

PACKAGE DRAWING (BGA package)

Unit:mm

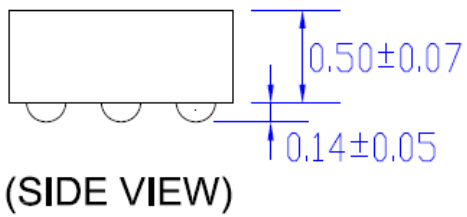
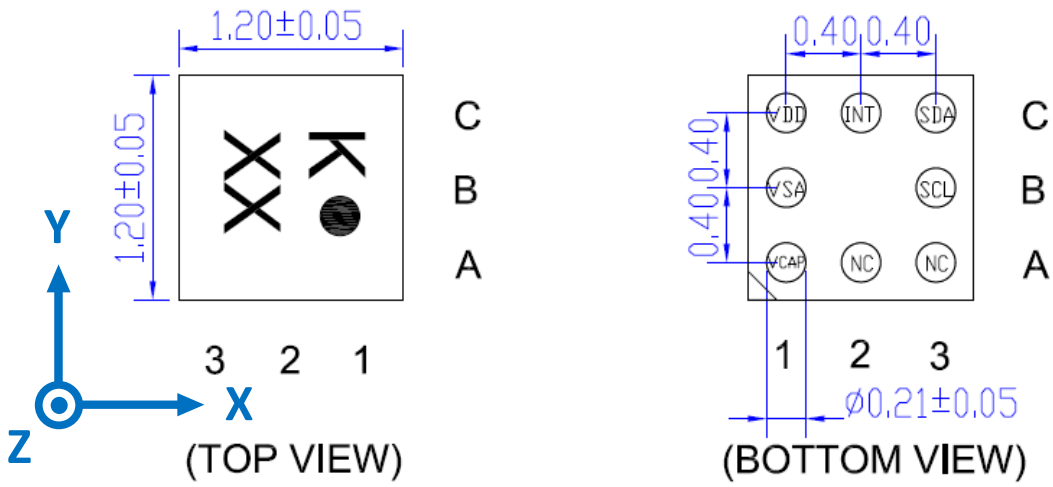

LAND PATTERN

Unit:mm

