



±30 Gauss, Monolithic, High Performance, Low Cost 3-axis Magnetic Sensor

MMC5603NJ

FEATURES

- Monolithic integrated 3-axis AMR magnetic sensor and electronic circuits requiring fewer external components
- Superior Dynamic Range and Accuracy:
 - ✓ ±30 G FSR
 - ✓ 20bits operation mode
 - ✓ 0.0625mG per LSB resolution
 - ✓ 2 mG total RMS noise
 - ✓ Enables heading accuracy of ±1°
- Sensor true frequency response up to 1KHz
- Ultra-Small Wafer Level Package 0.8x0.8x0.4 mm
- On-chip automatic degaussing with built-in SET/RESET function
 - ✓ Eliminates thermal variation induced offset error (Null field output)
 - ✓ Clears the residual magnetization resulting from strong external fields
- On-chip sensitivity compensation
- On-chip temperature sensor
- Selftest signal available
- Data_ready Interrupt (I3C only)
- Low power consumption
- 1 μA power down current
- I²C slave, FAST (≤400 KHz) mode
- I3C interface available
- 1.62V to 3.6V wide range single power supply
- 1.2V logic IO
- RoHS compliant

APPLICATIONS

- Electronic Compass & GPS Navigation
- Position Sensing

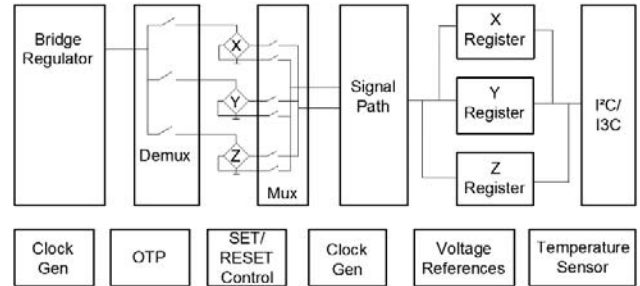

FUNCTIONAL BLOCK DIAGRAM

DESCRIPTION

The MMC5603NJ is a monolithic complete 3-axis AMR magnetic sensor with on-chip signal processing and integrated digital bus (I²C fast mode and I3C interface), the device can be connected directly to a microprocessor, eliminating the need for A/D converters or timing resources.

It can measure magnetic fields within the full scale range of ±30 Gauss (G), with up to 0.0625mG per LSB resolution at 20bits operation mode and 2mG total RMS noise level, enabling heading accuracy of ±1° in electronic compass applications. Contact MEMSIC for access to advanced calibration and tilt-compensation algorithms.

An integrated SET/RESET function provides for the elimination of error due to Null Field output change with temperature. In addition it clears the sensors of any residual magnetic polarization resulting from exposure to strong external magnets. The SET/RESET function can be performed for each measurement or periodically as the specific application requires.

The MMC5603NJ is in wafer level package with an ultra-small size of 0.8x 0.8 x 0.4 mm and with an operating temperature range from -40 °C to +85 °C.

Information furnished by MEMSIC is believed to be accurate and reliable. However, no responsibility is assumed by MEMSIC for its use, or for any infringements of patents or other rights of third parties which may result from its use. No license is granted by implication or otherwise under any patent or patent rights of MEMSIC.

©MEMSIC, Inc.
One Technology Drive, Suite 325, Andover, MA 01810, USA
Tel: +1 978 738 0900 Fax: +1 978 738 0196
www.memsic.com

SPECIFICATIONS (Measurements @ 25 °C, unless otherwise noted; V_{DD}= 1.8 V, Auto_SR_en=1, unless otherwise specified)

Parameter	Conditions	Min	Typ	Max	Units
Field Range (Each Axis) ¹	Total applied field		±30		G
Supply Voltage	V _{DD}	1.62	1.8	3.6	V
VIO		1.2	1.8	V _{DD}	V
Supply Voltage rise time				10.0	ms
Supply Current ^{2,3} (100 measurements/second)	BW=00		3.4	4.0	mA
	BW=01		2.4	3.0	mA
	BW=10		1.3	1.6	mA
	BW=11		0.75	1.0	mA
Power Down Current ³			1.0	1.2	µA
Operating Temperature		-40		85	°C
Storage Temperature		-55		125	°C
Linearity Error ³ (Best fit straight line)	FS=±30 G H _{applied} =±15 G		0.5	0.75	%FS
Hysteresis ³	3 sweeps across ±30 G		0.02	0.1	%FS
Repeatability Error ³	3 sweeps across ±30 G		0.02	0.1	%FS
Alignment Error			±1.0	±3.0	Degrees
Transverse Sensitivity			±2.0	±5.0	%
Total RMS Noise ³	BW=00		1.5	2.5	mG
	BW=01		2.0	4.0	mG
	BW=10		3.0	5.0	mG
	BW=11		4.0	7.0	mG
Output resolution			20		Bits
Max Output data rate ⁴	BW=00	75			Hz
	BW=01	150			Hz
	BW=10	255			Hz
	BW=11	255		1000	Hz
Heading accuracy ^{3,5}			±1.0	±3.0	Degrees
Sensitivity ^{3,6,8}	±30 G	-5		5	%
	With 16bits operation		1024		counts/G
	With 18bits operation		4096		counts/G
	With 20bits operation		16384		counts/G
Sensitivity Change Over Temperature ³	-40~85 °C Delta from 25 °C±30 G			±5	%
Null Field Output ⁸		-1.0		1.0	G
	With 16bits operation		32768		Counts
	With 18bits operation		131072		Counts
	With 20bits operation		524288		Counts
Null Field Output Change Over Temperature ³			±0.2	±1.0	mG/°C
Temperature Sensor Output ³		0.6	0.8	1.0	°C/Count
Disturbing Field ⁷		32			G
Maximum Exposed Field				10,000	G
Output Repeatability ³			2.0	3.0	mG

NOTES:

- External magnetic field on each axis not continuously higher than 16G.
- Supply current is proportional to how many measurements performed per second, 75Hz (maximum) for BW=00.
- Based on 3lots characterization result.
- The 1000 Hz ODR is available by writing 255 into Register ODR and setting hpower to 1.
- MEMSIC product enables users to utilize heading accuracy to be 1.0 degree typical when using MEMSIC's proprietary software or algorithm.
- Sensitivity of the orthogonal axes is analytically derived from raw data and is subsequently processed by MEMSIC software drivers.
- This is the magnitude of external field that can be tolerated without changing the sensor characteristics. If the disturbing field is exceeded, a SET/RESET operation is required to restore proper sensor operation.
- Based on shipment test result.

I²C INTERFACE I/O CHARACTERISTICS (V_{IO}=1.8 V)

Parameter	Symbol	Test Condition	Min.	Typ.	Max.	Unit
Logic Input Low Level	V _{IL}		-0.5		0.3* V _{IO}	V
Logic Input High Level	V _{IH}		0.7*V _{IO}		V _{IO}	V
Hysteresis of Schmitt input	V _{hys}		0.2			V
Logic Output Low Level	V _{OL}				0.4	V
Input Leakage Current	I _i	0.1V _{IO} <V _{in} <0.9V _{IO}	-10		10	μA
SCL Clock Frequency	f _{SCL}		0		400	kHz
START Hold Time	t _{HD;STA}		0.6			μS
START Setup Time	t _{SU;STA}		0.6			μS
LOW period of SCL	t _{LOW}		1.3			μS
HIGH period of SCL	t _{HIGH}		0.6			μS
Data Hold Time	t _{HD;DAT}		0		0.9	μS
Data Setup Time	t _{SU;DAT}		0.1			μS
Rise Time	t _r	From V _{IL} to V _{IH}			0.3	μS
Fall Time	t _f	From V _{IH} to V _{IL}			0.3	μS
Bus Free Time Between STOP and START	t _{BUF}		1.3			μS
STOP Setup Time	t _{SU;STO}		0.6			μS

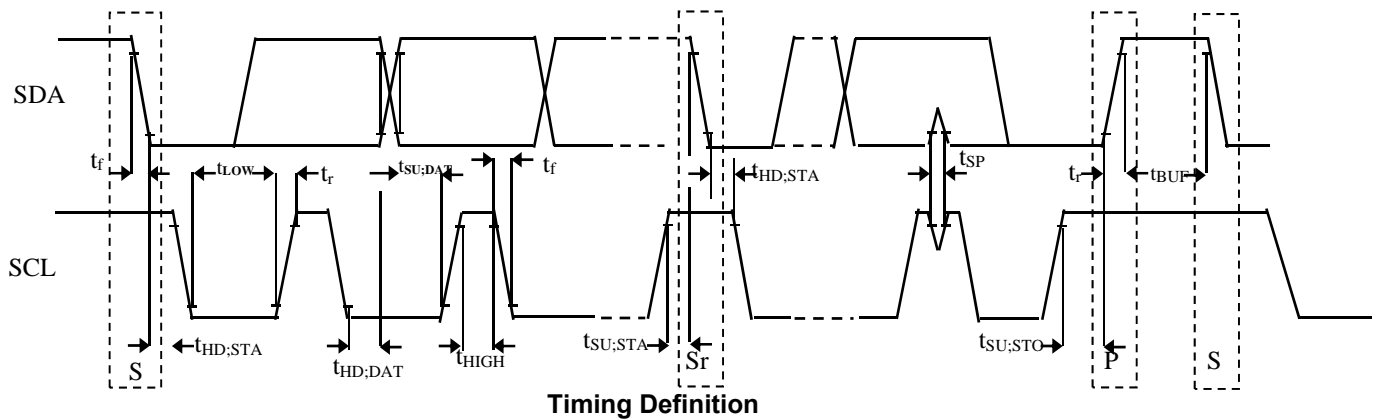

ABSOLUTE MAXIMUM RATINGS*

Supply Voltage	-0.5 to +5 V
Storage Temperature	-55 °C to +125 °C
Maximum Exposed Field	10000 G

Note: Stresses above those listed under Absolute Maximum Ratings may cause permanent damage to the device. This is a stress rating only; the functional operation of the device at these or any other conditions above those indicated in the operational sections of this specification is not implied. Exposure to absolute maximum rating conditions for extended periods may affect the device's reliability.

Pin Description: WLP Package

Pin	Name	Description	I/O
A1	VSA	Connect to Ground	P
A2	SCL	Serial Clock Line	I
B1	VDD	Power Supply	P
B2	SDA	Serial Data Line	I/O

All parts are shipped in tape and reel packaging with 10000pcs (or 5000pcs per requested) per 7" reel.

Caution:

This is an Electro-static Discharge (ESD) sensitive device.

Ordering Guide:

MMC5603NJ

Package type:

Code	Type
J	WLP package RoHS compliant

Performance Grade:

Code	Performance Grade
N	Temp compensated

MARKING ILLUSTRATION

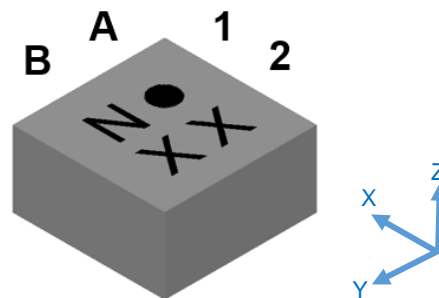

Note: "Number" (top-left character) is used to differentiate between similar devices. The black dot marks the location of pin one (1). The 2nd line represents the device's Lot Number.

THEORY OF OPERATION

The Anisotropic Magneto-Resistive (AMR) sensors are special resistors made of permalloy thin film deposited on a silicon wafer. During manufacturing, a strong magnetic field is applied to the film to orient its magnetic domains in the same direction, establishing a magnetization vector. Subsequently, an external magnetic field applied perpendicularly to the sides of the film causes the magnetization to rotate and change angle. This effect causes the film's resistance to vary with the intensity of the applied magnetic field. The MEMSIC AMR sensor is incorporated into a Wheatstone bridge configuration to maximize Signal to Noise ratio. A change in magnetic field produces a proportional change in differential voltage across the Wheatstone bridge.

However, the influence of a strong magnetic field (more than 30 G) in any direction could upset, or flip, the polarity of the film, thus changing the sensor characteristics. A strong restoring magnetic field must be applied momentarily to restore, or set, the sensor characteristics. The MEMSIC magnetic sensor has an on-chip magnetically coupled strap: a SET/RESET strap pulsed with a high current, to provide the restoring magnetic field.

EXTERNAL CIRCUITRY CONNECTION

The MMC5603NJ can operate from a single 1.62V to 3.6V supply. The circuit connection diagrams below illustrate power supply connection options.

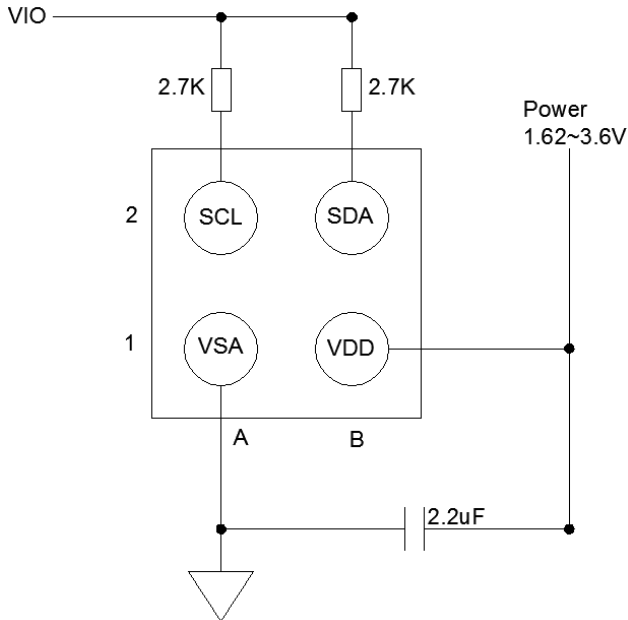

<TOP VIEW>

Connection Block Diagram

PIN DESCRIPTIONS

VDD – This is the power supply pin. MEMSIC recommends a minimum bypass capacitor of 2.2 μ F placed in close proximity to the VDD pin.

VSA – This is the ground pin for the magnetic sensor.

SDA – This pin is the I²C/I³C serial data line.

SCL – This pin is the I²C/I³C serial clock line.

HARDWARE DESIGN CONSIDERATION

- ✓ Provide adequate separation distance to devices that contain permanent magnets or generate magnetic fields (e.g. speakers, coils, inductors) The combined magnetic field to be measured and interference magnetic field should be less than the full scale range of the MMC5603NJ (± 30 G).
- ✓ Provide adequate separation distance to current carrying traces. Do not route current carrying traces under the sensor or on the other side of the PCB opposite the device.
- ✓ Do not cover the sensor with magnetized material or material that may become magnetized, (e.g., shield box, LCD, battery, iron bearing material).
- ✓ Do not place the device opposite magnetized material or material that may become magnetized located on the other side of the PCB.

Details please refer to MEMSIC Magnetic Sensor Hardware Design Layout Guideline for Electronic Device.

POWER CONSUMPTION

The power consumed by the device is proportional to the number of measurements taken per second. For example, when $BW < 1:0 > = 10$, MMC5603NJ consumes 1.3mA (typical) at 1.8V with 100 measurements per second. If only 1 measurements are performed per second, the current will be $1300 * 1 / 100 = 13 \mu A$.

I²C INTERFACE DESCRIPTION

A slave mode I²C circuit has been implemented into the MEMSIC magnetic sensor as a standard interface for customer applications. The A/D converter functionality have been added to the MEMSIC sensor, thereby increasing ease-of-use, and lowering power consumption, footprint and total solution cost.

The I²C (or Inter IC bus) is an industry standard bi-directional two-wire interface bus. A master I²C device can operate READ/WRITE controls to 128 devices by device addressing. The MEMSIC magnetic sensor operates only in a slave mode, i.e. only responding to calls by a master device.

I²C BUS CHARACTERISTICS

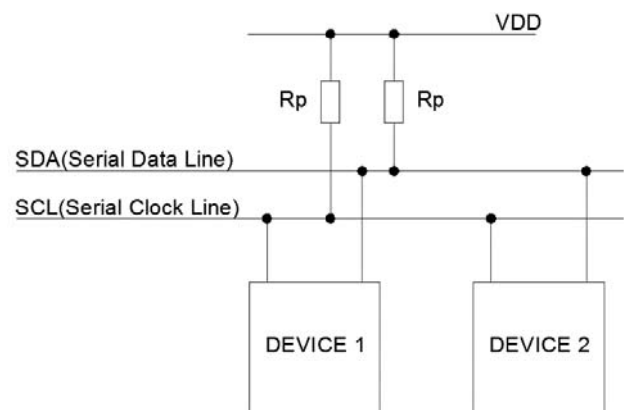

The two wires in the I²C bus are called SDA (serial data line) and SCL (serial clock line). In order for a data transfer to start, the bus has to be free, which is defined by both wires in a HIGH output state. Due to the open-drain/pull-up resistor structure and wired Boolean “AND” operation, any device on the bus can pull lines low and overwrite a HIGH signal. The data on the SDA line has to be stable during the HIGH period of the SCL line. In other words, valid data can only change when the SCL line is LOW.

Note: Rp selection guide: 2.7Kohm for a short I²C bus length (less than 10 cm), and 10Kohm for a bus length less than 5 cm.

REGISTER MAP

Register Name	Address (HEX)	Description
Xout0	00H	Xout[19:12]
Xout1	01H	Xout[11:4]
Yout0	02H	Yout[19:12]
Yout1	03H	Yout[11:4]
Zout0	04H	Zout[19:12]
Zout1	05H	Zout[11:4]
Xout2	06H	Xout[3:0]
Yout2	07H	Yout[3:0]
Zout2	08H	Zout[3:0]
Tout	09H	Temperature output
Status1	18H	Device status1
ODR	1AH	Output data rate
Internal control 0	1BH	Control register 0
Internal control 1	1CH	Control register 1
Internal control 2	1DH	Control register 2
ST_X_TH	1EH	X-axis selftest threshold
ST_Y_TH	1FH	Y-axis selftest threshold
ST_Z_TH	20H	Z-axis selftest threshold
ST_X	27H	X-axis selftest set value
ST_Y	28H	Y-axis selftest set value
ST_Z	29H	Z-axis selftest set value
Product ID	39H	Product ID

REGISTER DETAILS

Xout0, Xout1, Xout2

Xout0	7	6	5	4	3	2	1	0
Addr: 00H	Xout[19:12]							
Mode	Read-only							

Xout1	7	6	5	4	3	2	1	0
Addr: 01H	Xout[11:4]							
Mode	Read-only							

Xout2	7	6	5	4	3	2	1	0
Addr: 06H	Xout[3:0]				0	0	0	0
Mode	Read-only							

X-axis output, unsigned format.

X-axis output	Data
16bits operation mode	Xout[19:4]
18bits operation mode	Xout[19:2]
20bits operation mode	Xout[19:0]

Yout0, Yout1, Yout2

Yout0	7	6	5	4	3	2	1	0
Addr: 02H	Yout[19:12]							
Mode	Read-only							

Yout1	7	6	5	4	3	2	1	0
Addr: 03H	Yout[11:4]							
Mode	Read-only							

Yout2	7	6	5	4	3	2	1	0
Addr: 07H	Yout[3:0]				0	0	0	0
Mode	Read-only							

Y-axis output, unsigned format.

Y-axis output	Data
16bits operation mode	Yout[19:4]
18bits operation mode	Yout[19:2]
20bits operation mode	Yout[19:0]

Zout0, Zout1, Zout2

Zout0	7	6	5	4	3	2	1	0
Addr: 04H	Zout[19:12]							
Mode	Read-only							

Zout1	7	6	5	4	3	2	1	0
Addr: 05H	Zout[11:4]							
Mode	Read-only							

Zout2	7	6	5	4	3	2	1	0
	Zout[3:0]				0	0	0	0
Addr: 08H								
Mode	Read-only							

Z-axis output, unsigned format.

Z-axis output	Data
16bits operation mode	Zout[19:4]
18bits operation mode	Zout[19:2]
20bits operation mode	Zout[19:0]

Temperature Out

Temperature	7	6	5	4	3	2	1	0
Addr: 09H	Tout[7:0]							
Mode	Read-only							

Temperature output, unsigned format. The range is -75-125°C, about 0.8°C/LSB, 00000000 stands for -75°C

Status1

Device Status1	7	6	5	4	3	2	1	0
Addr: 18H	Meas_t_done	Meas_m_done	Sat_sensor	OTP_read_done	ST_Fail	Mdt_flag_int	Meas_t_done_int	Meas_m_done_int
Reset Value	0	0	0	0	0	0	0	0
Mode	Read-only							

Bit Name	Description
Meas_m_done_int	Factory use only, reset value is 0.
Meas_t_done_int	Factory use only, reset value is 0.
Mdt_flag_int	Factory use only, reset value is 0.
ST_Fail	Factory use only, reset value is 0.
OTP_read_done	This bit is an indicator of successfully reading its OTP memory either as part of its power up sequence, or after an I2C command that reloads the OTP memory, such as resetting the chip and refreshing the OTP registers.
Sat_sensor	This bit is an indicator of the selftest signal, it keeps low once the device PASS selftest.
Meas_m_done	This bit indicates that a measurement of magnetic field is done and the data is ready to be read. This bit is reset only when any of the magnetic data registers is read.
Meas_t_done	This bit indicates that a measurement of temperature is done and the data is ready to be read. This bit is reset only when the temperature register is read.

ODR

ODR	7	6	5	4	3	2	1	0
Addr: 1AH	ODR[7:0]							
Reset Value	0	0	0	0	0	0	0	0
Mode	Write-only							

Bit Name	Description																				
ODR[7:0]	<p>This byte defines the frequency of the continuous-mode measurements. In order to enter the continuous mode, this byte should not be zero. The configurable ODR is 1 to 255, with increment of 1. The 1000 Hz ODR is available by writing 255 into this byte and setting hpower to 1. The maximum reachable ODR as below:</p> <table border="1"> <thead> <tr> <th>BW</th> <th>Automatic SET/RESET</th> <th>No SET/RESET</th> <th>ODR range</th> </tr> </thead> <tbody> <tr> <td>00</td> <td>75Hz</td> <td>150 Hz</td> <td>1~75</td> </tr> <tr> <td>01</td> <td>150 Hz</td> <td>255 Hz</td> <td>1~150</td> </tr> <tr> <td>10</td> <td>255 Hz</td> <td>255 Hz</td> <td>1~255</td> </tr> <tr> <td>11</td> <td>255Hz</td> <td>hpower=0: 255 Hz; hpower=1: 1000 Hz</td> <td>1~255</td> </tr> </tbody> </table>	BW	Automatic SET/RESET	No SET/RESET	ODR range	00	75Hz	150 Hz	1~75	01	150 Hz	255 Hz	1~150	10	255 Hz	255 Hz	1~255	11	255Hz	hpower=0: 255 Hz; hpower=1: 1000 Hz	1~255
BW	Automatic SET/RESET	No SET/RESET	ODR range																		
00	75Hz	150 Hz	1~75																		
01	150 Hz	255 Hz	1~150																		
10	255 Hz	255 Hz	1~255																		
11	255Hz	hpower=0: 255 Hz; hpower=1: 1000 Hz	1~255																		

Internal Control 0

Control Register 0	7	6	5	4	3	2	1	0
Addr: 1BH	Cmm_freq_en	Auto_st_en	Auto_SR_en	Do Reset	Do Set	Start_MD_T	Take_meas_T	Take_meas_M
Reset Value	0	0	0	0	0	0	0	0
Mode	Write-only							

Bit Name	Description
Take_meas_M	Take Measure of Magnetic field, or TM_M bit. Writing a 1 into this location causes the chip to perform a magnetic measurement. This bit is self-clearing at the end of each measurement.
Take_meas_T	Take Measure of Temperature, or TM_T bit. Writing a 1 into this location causes the chip to perform a temperature measurement. This bit is self-clearing at the end of each measurement.
Start_MDT	Factory use only, reset value is 0.
Do Set	Writing a 1 into this location will cause the chip to do the Set operation, which will allow large set current to flow through the sensor coils for 375ns. This bit is self-cleared at the end of Set operation.
Do Reset	Writing a 1 into this location will cause the chip to do the Reset operation, which will allow large reset current to flow through the sensor coils for 375ns. This bit is self-cleared at the end of Reset operation.
Auto_SR_en	Writing a 1 into this location will enable the function of automatic set/reset. This function applies to both on-demand and continuous-time measurements. This bit must be set to 1 in order to activate the feature of periodic set. This bit is recommended to set to "1" in the application.
Auto_st_en	Writing a 1 into this location will enable the function of automatic self-test. The threshold in register 1EH, 1FH, 20H should be set before this bit is set to 1. This bit clears itself after the operation is completed.
Cmm_freq_en	Writing a 1 into this location will start the calculation of the measurement period according to the ODR. This bit should be set before continuous-mode measurements are started. This bit is self-cleared after the measurement period is calculated by internal circuits.

Internal Control 1

Control Register 1	7	6	5	4	3	2	1	0
Addr: 1CH	Sw_reset	St_enm	St_enp	Z-inhibit	Y-inhibit	X-inhibit	BW1	BW0
Reset Value	0	0	0	0	0	0	0	0
Mode	Write-only							

Bit Name	Description															
BW0 & BW1	These bandwidth selection bits adjust the length of the decimation filter. They control the duration of each measurement.															
	<table border="1"> <thead> <tr> <th>BW1</th> <th>BW0</th> <th>Measurement Time</th> </tr> </thead> <tbody> <tr> <td>0</td> <td>0</td> <td>6.6ms</td> </tr> <tr> <td>0</td> <td>1</td> <td>3.5ms</td> </tr> <tr> <td>1</td> <td>0</td> <td>2.0ms</td> </tr> <tr> <td>1</td> <td>1</td> <td>1.2ms</td> </tr> </tbody> </table>	BW1	BW0	Measurement Time	0	0	6.6ms	0	1	3.5ms	1	0	2.0ms	1	1	1.2ms
	BW1	BW0	Measurement Time													
	0	0	6.6ms													
	0	1	3.5ms													
1	0	2.0ms														
1	1	1.2ms														
Note: X/Y/Z channel measurements are taken sequentially. Delay Time among those measurements is 1/3 of the Measurement Time defined in the table.																
X-inhibit	Writing "1" will disable this channel, and reduce Measurement Time and total charge per measurement. When a channel is disabled it is simply skipped during Take Measure routine. Its output register is not reset and will maintain the last value written to it when this channel was active. Note: Y/Z needs to be inhibited the same time in case needed.															
Y-inhibit																
Z-inhibit																
St_enp	Writing 1 into this location will bring a DC current through the self-test coil of the sensor. This current will cause an offset of the magnetic field. This function is used to check whether the sensor has been saturated.															
St_enm	The function of this bit is similar to ST_ENP, but the offset of the magnetic field is of opposite polarity.															

Sw_reset	Software Reset. Writing "1" will cause the part to reset, similar to power-up. It will clear all registers and also re-read OTP as part of its startup routine. The power on time is 20mS.
----------	--

Internal Control 2

Control Register 2	7	6	5	4	3	2	1	0
Addr: 1DH	hpower	INT_meas_done_en	INT_mdt_en	Cmm_en	En_prd_set	Prd_set[2:0]		
Reset Value	0	0	0	0	0	0	0	0
Mode	Write-only							

Bit Name	Description
Prd_set[2:0]	These bits determine how many measurements are done before a set is executed, when the part is in continuous mode and the automatic set/reset is enabled. From 000 to 111, the sensor will do one set for every 1, 25, 75, 100, 250, 500, 1000, and 2000 samples. In order to enable this feature, both En_prd_set and Auto_SR must be set to 1, and the part should work in continuous mode. Please note that during this operation, the sensor will not be reset.
En_prd_set	Writing 1 into this location will enable the function of periodical set.
Cmm_en	The device will enter continuous mode, if ODR has been set to a non-zero value and a 1 has been written into Cmm_freq_en. The internal counter will start counting as well since this bit is set.
INT_mdt_en	Factory use only, reset value is 0.
INT_meas_done_en	Factory use only, reset value is 0.
hpower	If this bit is set to 1 to achieve 1000Hz ODR.

ST_X_TH

ST_X_TH	7	6	5	4	3	2	1	0
Addr: 1EH	ST_X_TH[7:0]							
Reset Value	0	0	0	0	0	0	0	0
Mode	Write-only							

X-axis selftest threshold

ST_Y_TH

ST_Y_TH	7	6	5	4	3	2	1	0
Addr: 1FH	ST_Y_TH[7:0]							
Reset Value	0	0	0	0	0	0	0	0
Mode	Write-only							

Y-axis selftest threshold

ST_Z_TH

ST_Z_TH	7	6	5	4	3	2	1	0
Addr: 20H	ST_Z_TH[7:0]							
Reset Value	0	0	0	0	0	0	0	0
Mode	Write-only							

Z-axis selftest threshold

ST_X

ST_X	7	6	5	4	3	2	1	0
Addr: 27H	ST_X[7:0]							
Reset Value	Factory stored value							
Mode	Read/Write							

X-axis selftest set value

ST_Y

ST_Y	7	6	5	4	3	2	1	0
Addr: 28H	ST_Y[7:0]							
Reset Value	Factory stored value							
Mode	Read/Write							

Y-axis selftest set value

ST_Z

ST_Z	7	6	5	4	3	2	1	0
Addr: 29H	ST_Z[7:0]							
Reset Value	Factory stored value							
Mode	Read/Write							

Z-axis selftest set value

Product ID 1

Product ID 1	7	6	5	4	3	2	1	0
Addr: 39H	Product ID1[7:0]							
Reset Value	0	0	0	1	0	0	0	0
Mode	Read-only							

Product ID, used to recognize device.

I²C INTERFACE OPERATION:

DATA TRANSFER

A data transfer is started with a “START” condition and ended with a “STOP” condition. A “START” condition is defined by a HIGH to LOW transition on the SDA line while SCL line is HIGH. A “STOP” condition is defined by a LOW to HIGH transition on the SDA line while the SCL line is held HIGH. All data transfer in I²C system are 8-bits long. Each byte has to be followed by an acknowledge bit. Each data transfer involves a total of 9 clock cycles. Data is transferred starting with the most significant bit (MSB).

After a START condition, the master device calls a specific slave device by sending its 7-bit address with the 8th bit (LSB) indicating that either a READ or WRITE operation will follow, [1] for READ and [0] for WRITE. The MEMSIC device 7-bit device address is **[0110000]** where the three LSB's are pre-programmed into the MMC5603NJ by the factory.

Note: A total of 8 different addresses can be pre-programmed into MEMSIC device by the factory. This variation of I²C address avoids a potential address conflict, either by ICs from other manufacturers or by other MEMSIC devices on the same bus.

The initial addressing of the slave is always followed by the master writing the number of the slave register to be read or written, so this initial addressing always indicates a WRITE operation by sending **[01100000]**. After being addressed, the MEMSIC device being called should respond by an “Acknowledge” signal by pulling SDA line LOW. Subsequent communication bytes can either be

- a) The data to be written to the device register, or
- b) Another START condition followed by the device address indicating a READ operation **[01100001]**, and then the master reads the register data.

Multiple data bytes can be written or read to numerically sequential registers without the need of another START condition. Data transfer is terminated by a STOP condition or another START condition. Two detailed examples of communicating with the MEMSIC device are listed below for the actions of acquiring a magnetic field measurement and magnetizing the sensor.

EXAMPLE OF MEASUREMENT

1st cycle: A START condition is established by the Master Device followed by a call to the slave address **[0110000]** with the eighth bit held low to indicate a WRITE request.

2nd cycle: After an acknowledge signal is received by the master device (MEMSIC device pulls SDA line low during 9th SCL pulse), the master device sends the address of Control Register 0 as the target register to

be written. The MEMSIC device should acknowledge receipt of the address (9th SCL pulse, SDA pulled low).

3rd cycle: The Master device writes to the Internal Control Register 0 the code **[00100001]** (TM_M and Auto_SR_en high) to initiate data acquisition. The MEMSIC device should send an Acknowledge and internally initiate a measurement (collect x, y and z data). A STOP condition indicates the end of the write operation.

4th cycle: The Master device sends a START command followed by the MEMSIC device's seven bit address, and finally the eighth bit set low to indicate a WRITE. An Acknowledge should be send by the MEMSIC device in response.

5th cycle: The Master device sends the MEMSIC Device Status Register1 as the address to read.

6th cycle: The Master device sends a START command followed by the MEMSIC device's seven bit address, and finally the eighth bit set high to indicate a READ. An Acknowledge should be send by the MEMSIC device in response.

7th cycle: The Master device cycles the SCL line. This causes the Status Register data to appear on SDA line. Continuously read the Device Status Register1 until the Meas_M_Done bit (bit 1) is set to '1'. This indicates that data for the x, y, and z sensors is available to be read.

8th cycle: The Master device sends a START command followed by the MEMSIC device's seven bit address, and finally the eighth bit set low to indicate a WRITE. An Acknowledge should be send by the MEMSIC device in response.

9th cycle: The Master device sends a **[00000000]** (Xout LSB register address) as the register address to read.

10th cycle: The Master device calls the MEMSIC device's address with a READ (8th SCL cycle SDA line high). An Acknowledge should be send by the MEMSIC device in response.

11th cycle: Master device continues to cycle the SCL line, and each consecutive byte of data from the X, Y and Z registers should appear on the SDA line. The internal memory address pointer automatically moves to the next byte. The Master device acknowledges each. Thus:

12th cycle: Xout[19:12].

13th cycle: Xout[11:4].

14th cycle: Yout[19:12].

15th cycle: Yout[11:4].

16th cycle: Zout[19:12].

17th cycle: Zout[11:4].

18th cycle: Xout[3:2] for 18bits mode. Xout[3:0] for 20bits mode

19th cycle: Yout[3:2] for 18bits mode. Yout[3:0] for 20bits mode

20th cycle: Zout[3:2] for 18bits mode. Zout[3:0] for 20bits mode:0].

Master ends communications by NOT sending an 'Acknowledge' and also follows with a 'STOP' command.

EXAMPLE OF CONTINUOUS MODE

The MMC5603NJ is designed with an on-chip continuous mode, or CMM. When enabled, the part will periodically take a measurement and store the results in I²C register. The frequency of these measurements is controlled by a setting in I²C register. The results of the last measurement can be read by the host. This mode, while it consumes more current, eliminates the need for the host to request measurements every time.

First the user needs to write the desired number into ODR[7:0]. It should be a non-zero integer, otherwise the continuous mode will not be activated. Then Cmm_freq_en is set to 1 to let the internal circuitry to calculate the target number for the counter. After that Cmm_en is set to 1 and the continuous mode is started and the internal counter starts to count at the same time.

EXAMPLE OF SET

1st cycle: A START condition is established by the Master Device followed by a call to the slave address [0110000] with the eighth bit held low to indicate a WRITE request.

2nd cycle: After an acknowledge signal is received by the master device (The MEMSIC device pulls the SDA line low during the 9th SCL pulse), the master device sends [00011011] as the target address (Internal Control Register 0). The MEMSIC device should acknowledge receipt of the address (9th SCL pulse).

3rd cycle: The Master device writes to the MEMSIC device's Internal Control 0 register the code [00001000] (SET bit) to initiate a SET action. The MEMSIC device should send an Acknowledge.

EXAMPLE OF RESET

1st cycle: A START condition is established by the Master Device followed by a call to the slave address [0110000] with the eighth bit held low to indicate a WRITE request.

2nd cycle: After an acknowledge signal is received by the master device (The MEMSIC device pulls the SDA line low during the 9th SCL pulse), the master device sends [00011011] as the target address (Internal Control Register 0). The MEMSIC device should acknowledge receipt of the address (9th SCL pulse).

3rd cycle: The Master device writes to the MEMSIC device's Internal Control 0 register the code [00010000] (RESET bit) to initiate a RESET action. The MEMSIC device should send an Acknowledge.

At this point, the MEMSIC AMR sensors have been conditioned for optimum performance and data measurements can commence.

Note:

- The RESET action can be skipped for most applications

USING SET AND RESET TO REMOVE BRIDGE OFFSET

The integrated SET and RESET functions of the MMC5603NJ enables the user to remove the error associated with bridge Offset change as a function of temperature, thereby enabling more precise heading measurements over a wider temperature than competitive technologies. The SET and RESET functions effectively alternately flip the magnetic sensing polarity of the sensing elements of the device.

- 1) The most accurate magnetic field measurements can be obtained by using the protocol described as follows: Perform SET. This sets the internal magnetization of the sensing resistors in the direction of the SET field.
Output1 = +H + Offset.
- 2) Perform MEASUREMENT. This measurement will contain not only the sensors response to the external magnetic field, H, but also the Offset; in other words,
Output2 = -H + Offset.
- 3) Perform RESET. This resets the internal magnetization of the sensing resistors in the direction of the RESET field, which is opposite to the SET field (180° opposed).
- 4) Perform MEASUREMENT. This measurement will contain both the sensors response to the external field and also the Offset. In other words,
Output2 = -H + Offset.
- 5) Finally, calculate H by subtracting the two measurements and dividing by 2. This procedure effectively eliminates the Offset from the measurement and therefore any changes in the Offset over temperature.
H = (Output1-Output2)/2.

Note:

- To calculate and store the offset; add the two measurements and divide by 2. This calculated offset value can be subtracted from subsequent measurements to obtain H directly from each measurement.





EXAMPLE OF SELFTEST

The MMC5603NJ is designed with an on-chip selftest signal to do self-diagnose of the sensor:

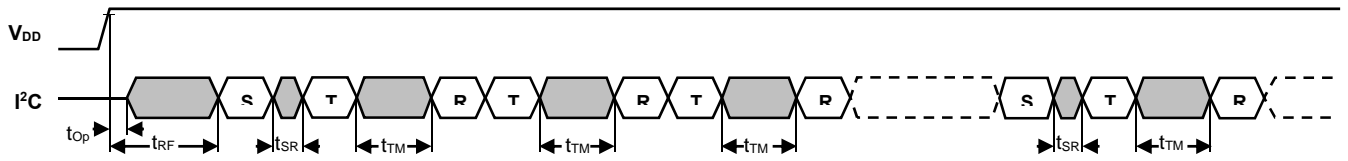
- 1) Read out the selftest signal stored at register 27H, 28H, and 29H.
- 2) Calculate the selftest signal threshold with 80% of the data readout from above registers.
- 3) Write the threshold in to the register 1EH, 1FH, and 20H.
- 4) Write [01000001] (TM_M and auto_st_en high) to Internal Control Register 1BH to initiate a selftest.
- 5) Read out value of Sat_sensor bit at the Device Status register 18H.
- 6) Sat_sensor=0, PASS selftest.

OPERATING TIMING



-  SET/RESET
-  Take Measurement
-  Read data
-  Repeat T & R
-  Wait the device to be ready for next operation

Operating Timing Diagram

Parameter	Symbol	Min.	Max.	Unit
Time to operate device after V_{DD} valid	t_{Op}	5		ms
Minimum time interval between SET or RESET to other operations	t_{SR}	1		ms
	t_{TM} BW=00	6.6		ms
	t_{TM} BW=01	3.5		ms
	t_{TM} BW=10	2.0		ms
	t_{TM} BW=11	1.2		ms

SOLDERING RECOMMENDATIONS

MEMSIC magnetic sensor is capable of withstanding an MSL1 / 260 °C solder reflow. Following is the reflow profile:

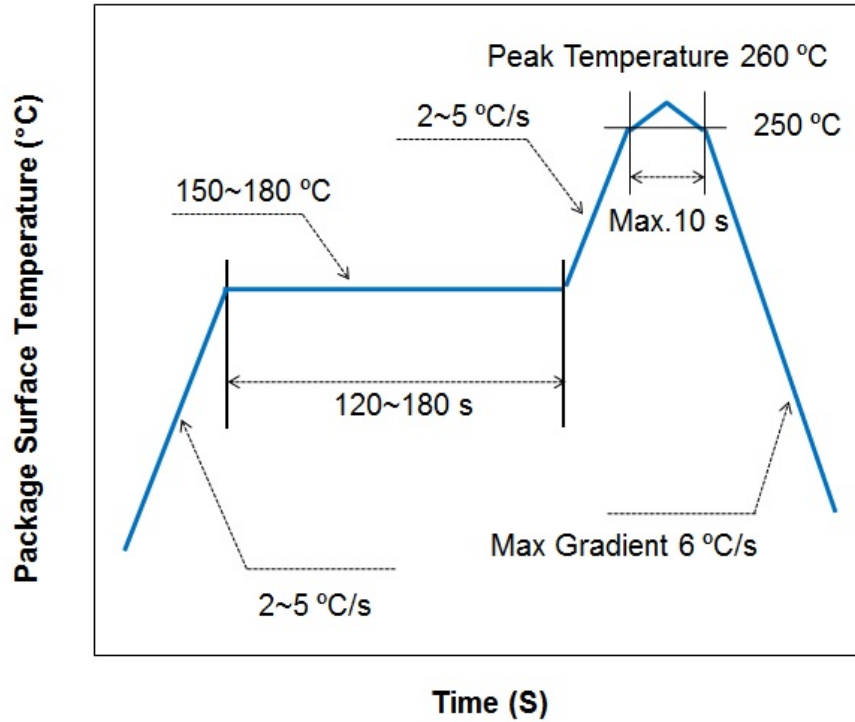

Note:

- The second reflow cycle should be applied after device has cooled down to 25 °C (room temperature)
- This is the reflow profile for Pb free process
- The peak temperature on the sensor surface should be limited under 260 °C for 10 seconds.
- Solder paste's reflow recommendation should be followed to get the best SMT quality.

If the part is mounted manually, please ensure the temperature could not exceed 260 °C for 10 seconds.

PACKAGE DRAWING (WLP package)

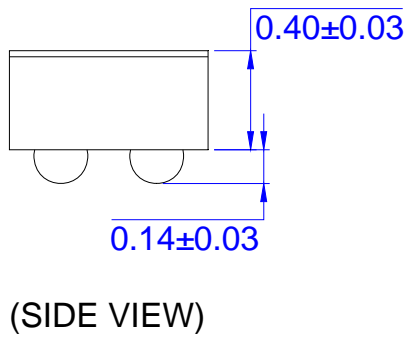
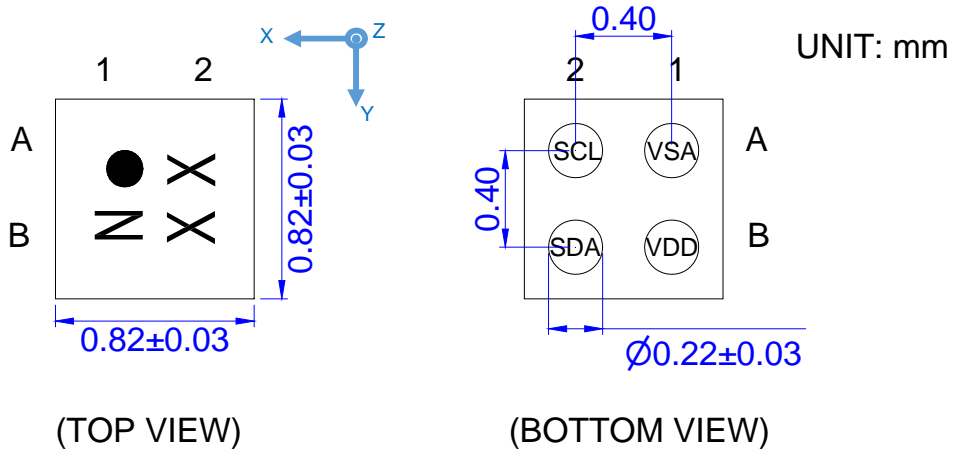

RECOMMENDED LAND PATTERN DESIGN

UNIT: mm

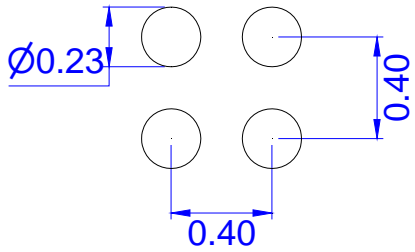

RELATIONSHIP BETWEEN THE MAGNETIC FIELD AND OUTPUT CODE

The measurement data increases as the magnetic flux density increases in the arrow directions.

