

### Iridium Antenna

---

- **Cost effective**
- **Robust & Waterproof**
- **Easy Installation**
- **IPx7 class**
- **Clear and Stable Signals**



ADA-1590IR-S is a Low Profile Magnetic Mount Antenna.

ADA-1590IR-S is part of a family of Iridium Antennas specifically designed to provide excellent coverage in the 1616 to 1626.5 MHz range.

Available with two different mounting concepts, centre bolt or magnetic mount.

## Specification

Category	Electrical Performance
Frequency	1616 ~ 1626.5 MHz
Polarization	R.H.C.P.
Power Gain	Typ. 2.5 dBi
Rated Power	10 W
Output Impedance	50 $\Omega$
VSWR	$\leq 2.0:1$
Azimuth	360 Degree
Elevation	0 – 90 degree
RF Cable	Standard RG174/U with standard connector, SMA, FME
	Mechanical
Size	65,5 x 17.1 mm (D x H)
Mounting	Magnetic Mount
Operating temperature	-40 – +85 ° C
Storage temperature	-45 – +100 ° C

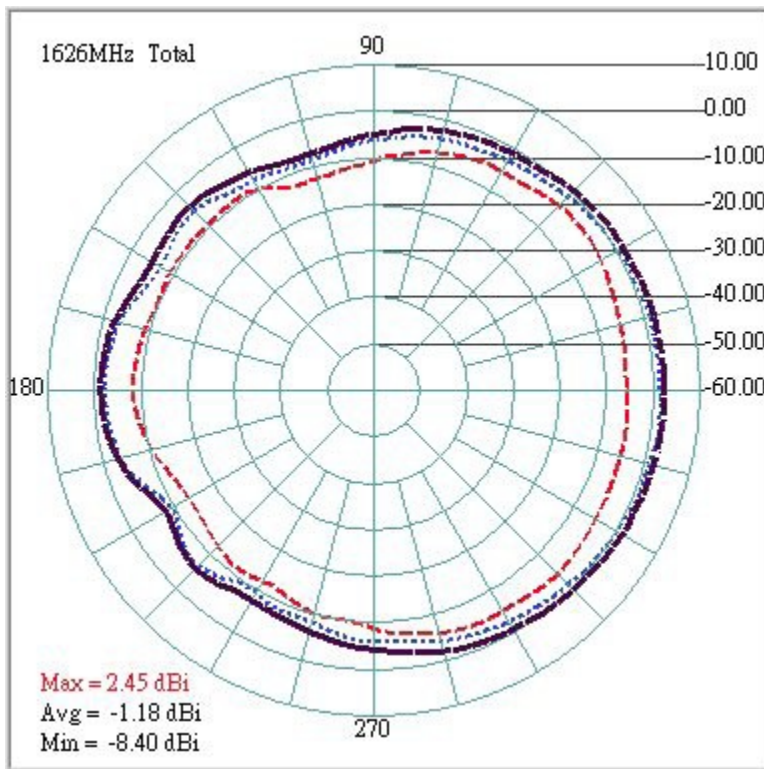
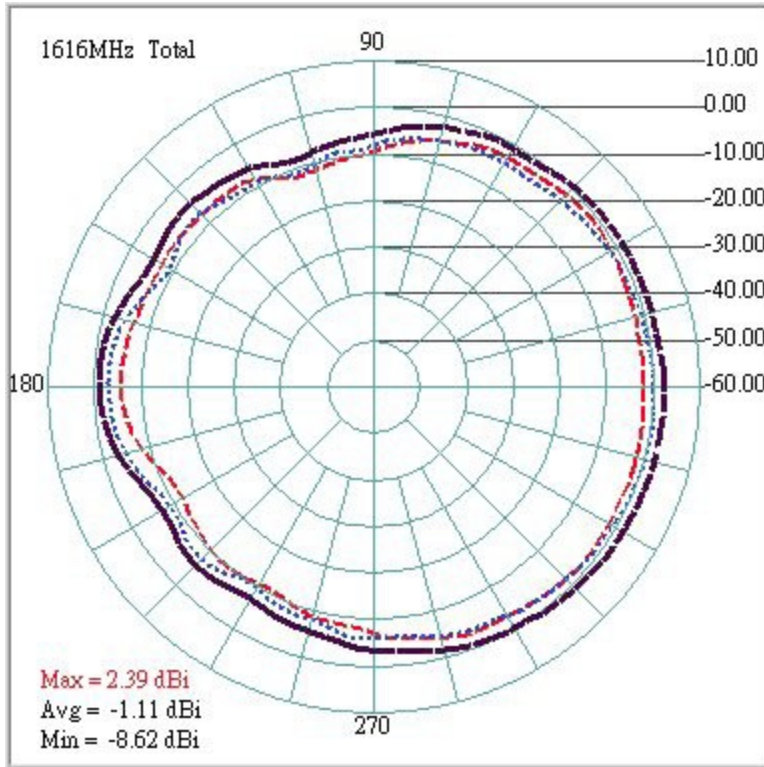

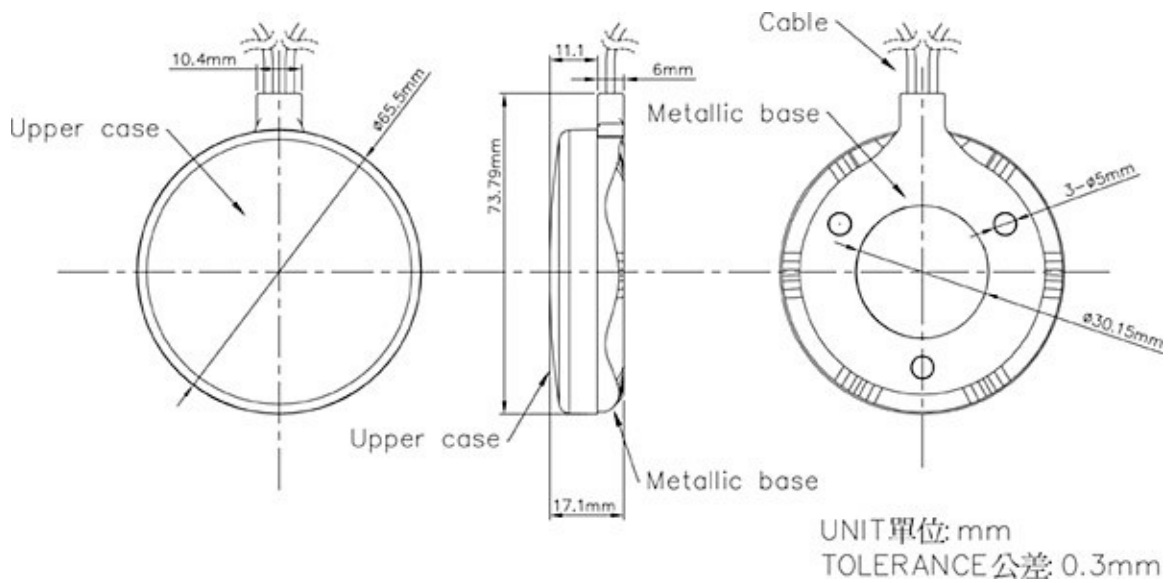
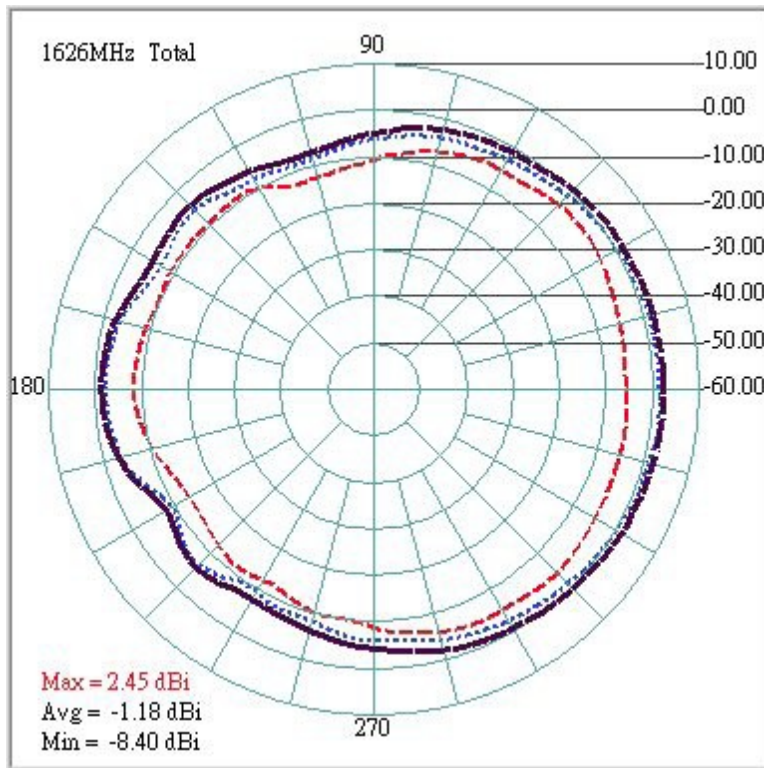

## Ordering codes

TYPE	Description	Comment
ADA-1590IR-S	Iridium Antenna	Cable Length and Connector

The antennas are delivered with different antenna cable lengths and different connectors. Contact Adactus or our distributor for a quote for any particular specification.

For the latest updates, visit our Web site: [www.adactus.se](http://www.adactus.se)

### **Disclaimer**

Information furnished is believed to be accurate and reliable. However, Adactus assumes no responsibility for the consequences of use of such information nor for any infringement of patents or other rights of third parties which may result from its use.

Adactus reserves the right to make changes without further notice to any product herein to improve reliability, function or design. Adactus does not assume any liability arising out of the application or use of any product described herein.

This publication supersedes and replaces all information previously supplied.

Adactus products are not authorized as critical components in life support devices or systems.