

OVERVIEW

GALILEO - CMX
COMBER

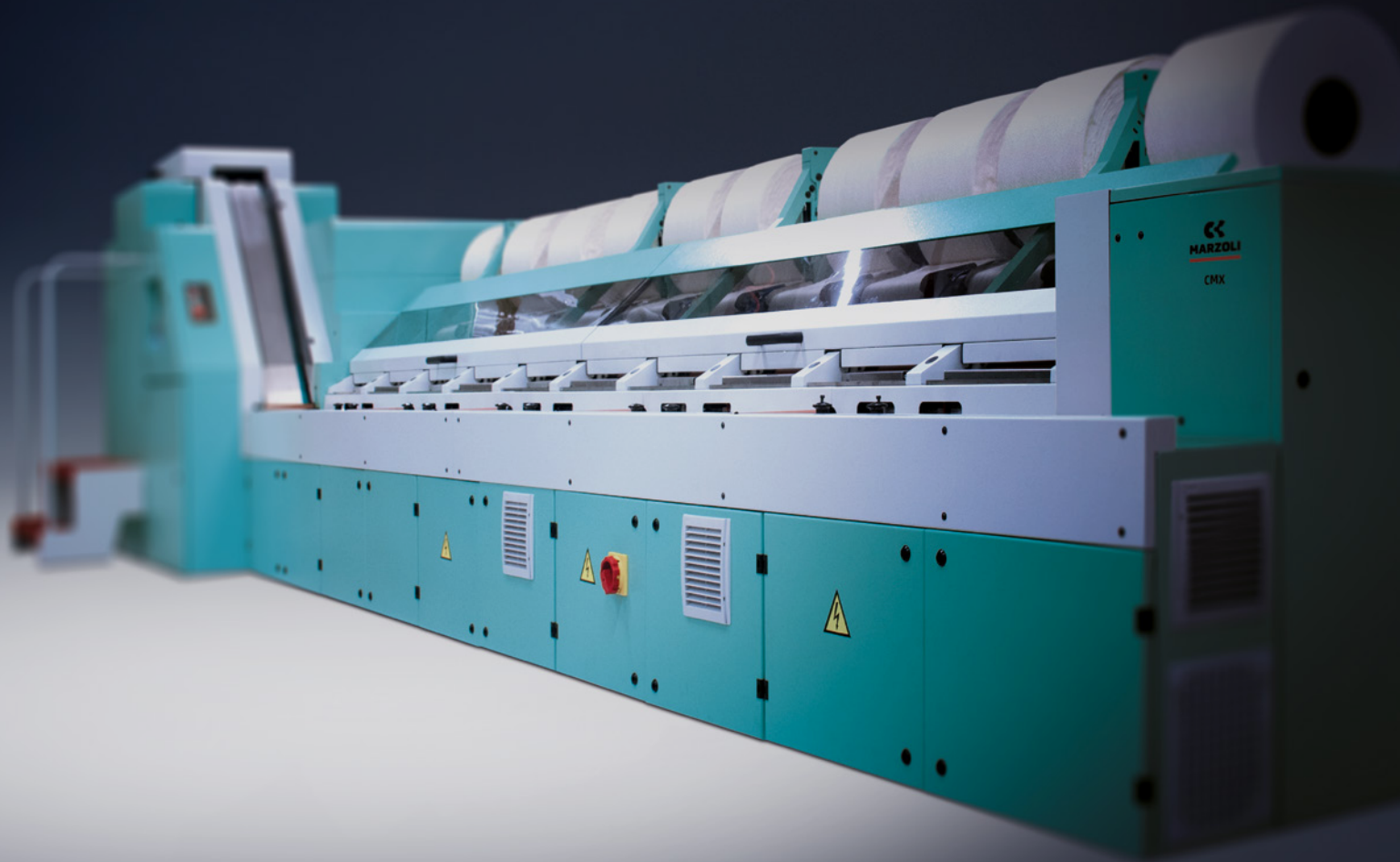

CMX COMBER

The 10 combing heads machine

Marzoli has a long-standing tradition in the design and development of combers for short-staple fibers. The CMX is the result of a thorough activity of research and development that has led to the achievement of the maximum results on:

- Quality (substantial reduction of neps and short fibers, perfect evenness of the sliver);
- Productivity (mechanical speed up to 600 nips/min with production volumes up to 115 Kg/h);
- Efficiency (reduction in energy consumption, reduction of long fibers in the waste and reduction of noil percentage);

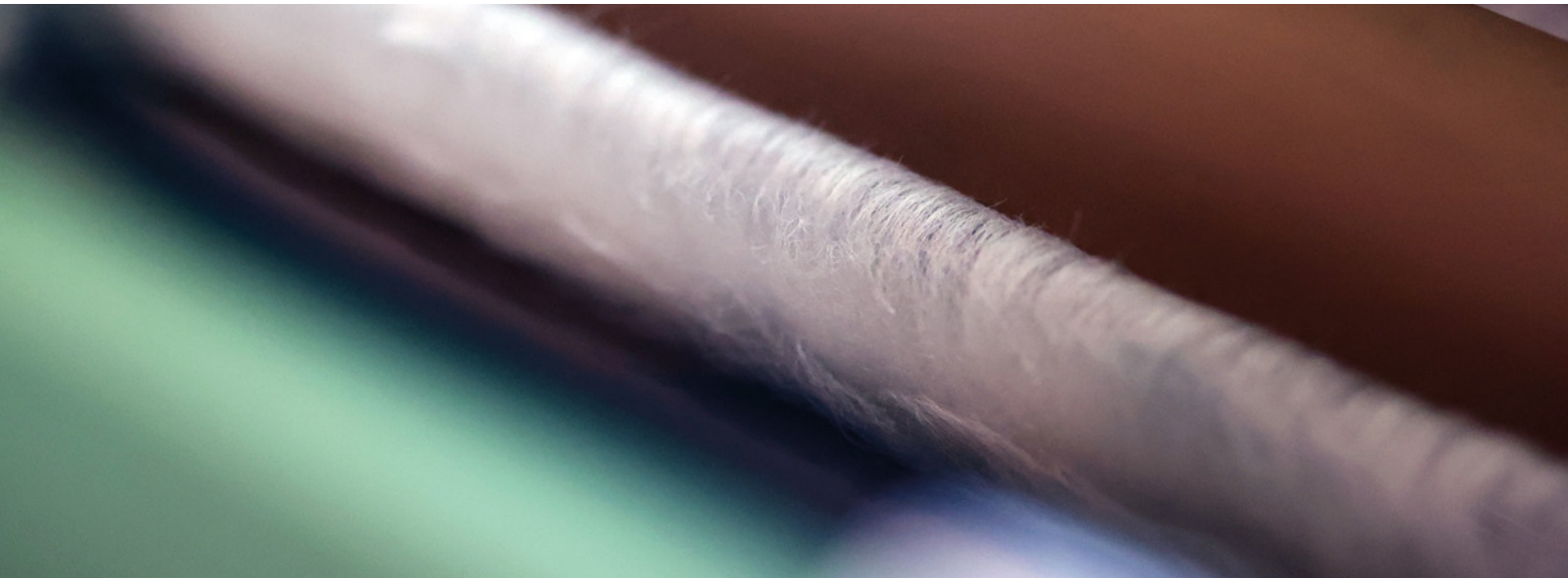

Webs are generally superimposed through the alternating motion of the detaching rollers. This type of motion, which generates high levels of torsional stress, limits the number of combing heads available in each machine. Regardless of whether the machine is mechanically or electrically operated, the number of combing heads is generally limited to 8. As a result of intense and ambitious R&D activities, Marzoli has succeeded in superimposing webs through the continuous motion of the detaching rollers, limiting the level torsional of stress generated.

The output sliver's count of the combing head can be set through a touch screen.



■ INNOVATIVE TECHNOLOGY

This innovation opens the door to many opportunities:

- The number of combing heads can be increased to 10, resulting in a 25% increase in production capacity compared to traditional combing machines at the same working conditions.
- Electricity consumption is significantly reduced due to the lack of motion reversal of the detaching rollers. In fact, traditional motion requires greater energy expenditure for both 'mechanically' operated detaching rollers and those with individual drives.
- A substantial reduction of technological air consumption, since the required air flow rate is that strictly required to keep the circular comb brushes clean.

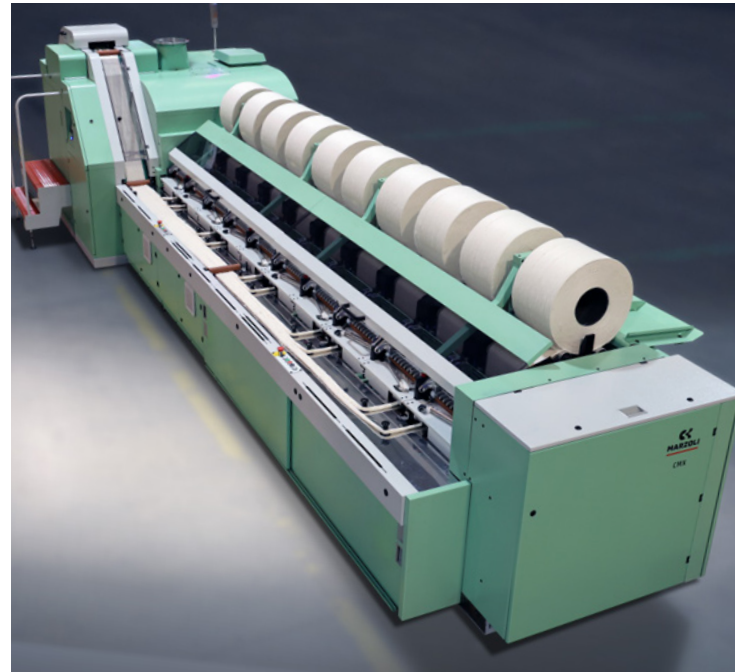

The main machine motions are entirely set up using the on-board touchscreen.

The amount of superimposition can also be set by changing a single parameter.

This makes the machine easy and intuitive to use.

The drafting unit of the Comber CMx is designed to improve control of the cotton fiber processed. 10 slivers fed from the combing heads are drafted through 3+1 top rollers coupled with 4 bottom cylinders with rubber scrapers. Unlike the draw frame, whose design seeks the best compromise between quality and working speed, the main aim of the comber is to achieve the best possible sliver regularity.

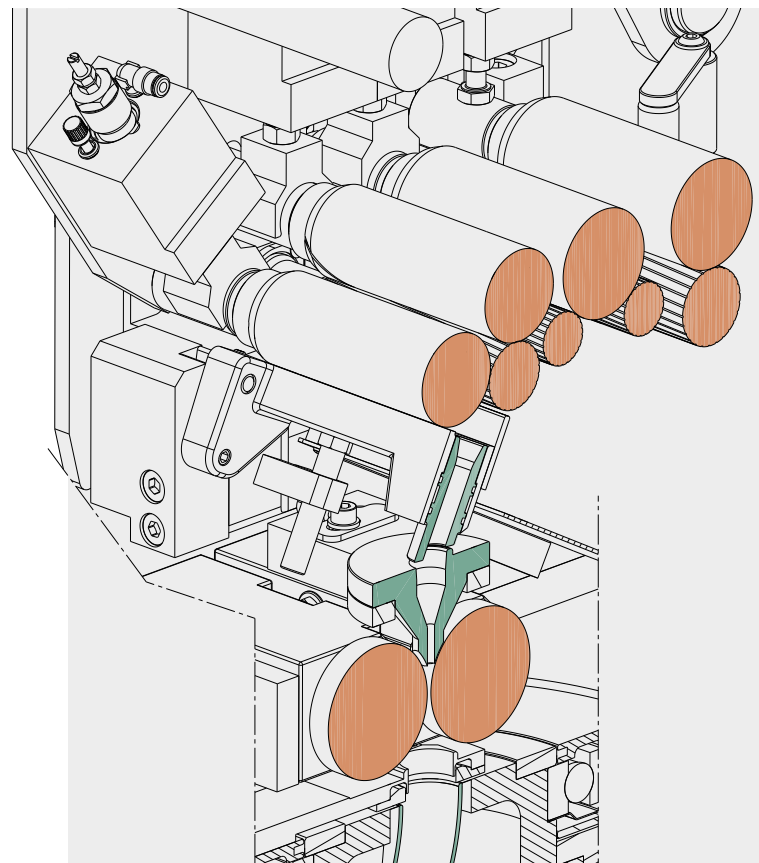

MARZOLI CMX WITH CONTINUOUS MOTION OF THE DETACHING ROLLERS

An historic innovation to disclose a whole new series of advantages

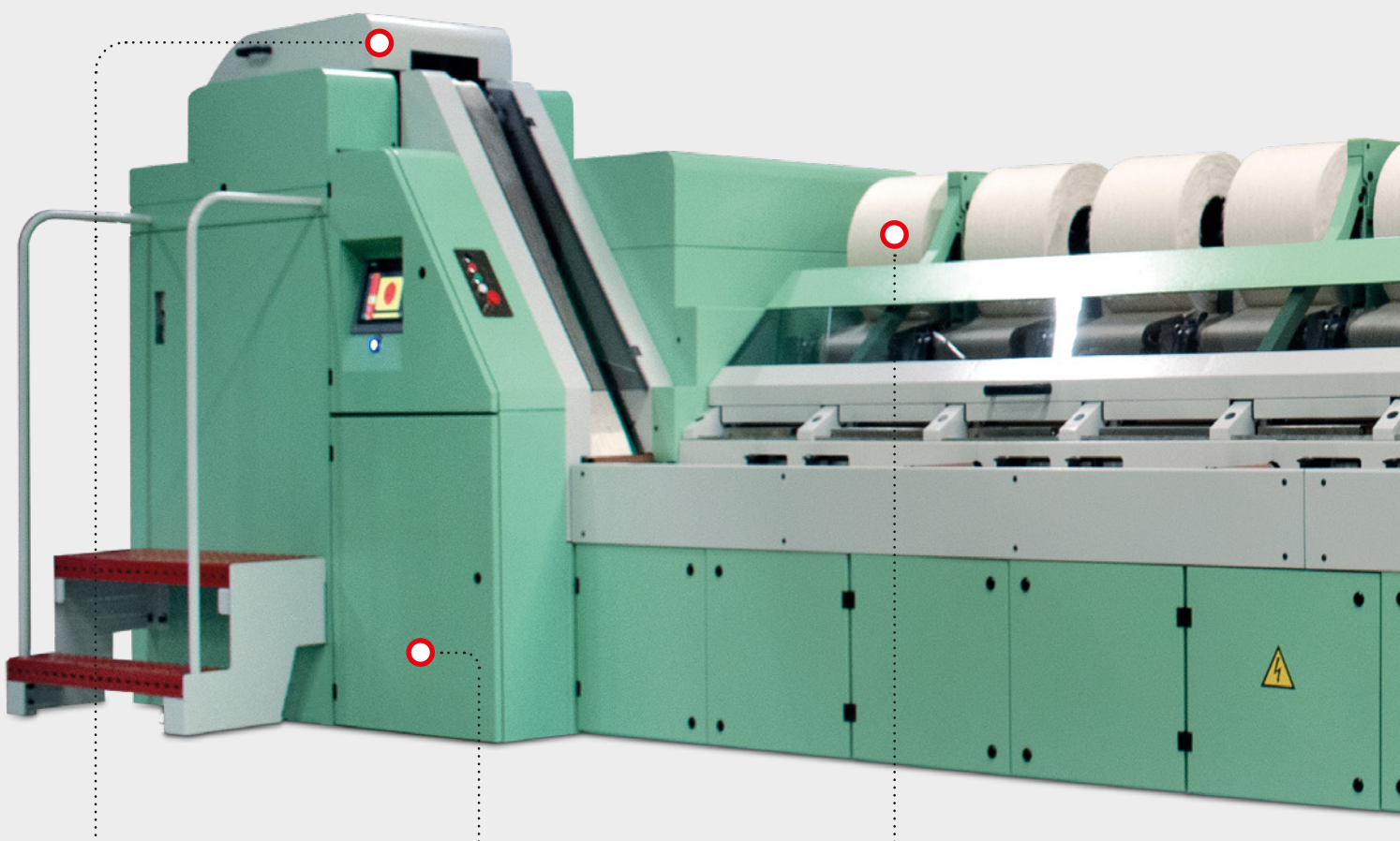

- High performance 3 over 4 drafting system

- - 50% suction

- 10 combing heads +25% production (up to 115 kg/h)

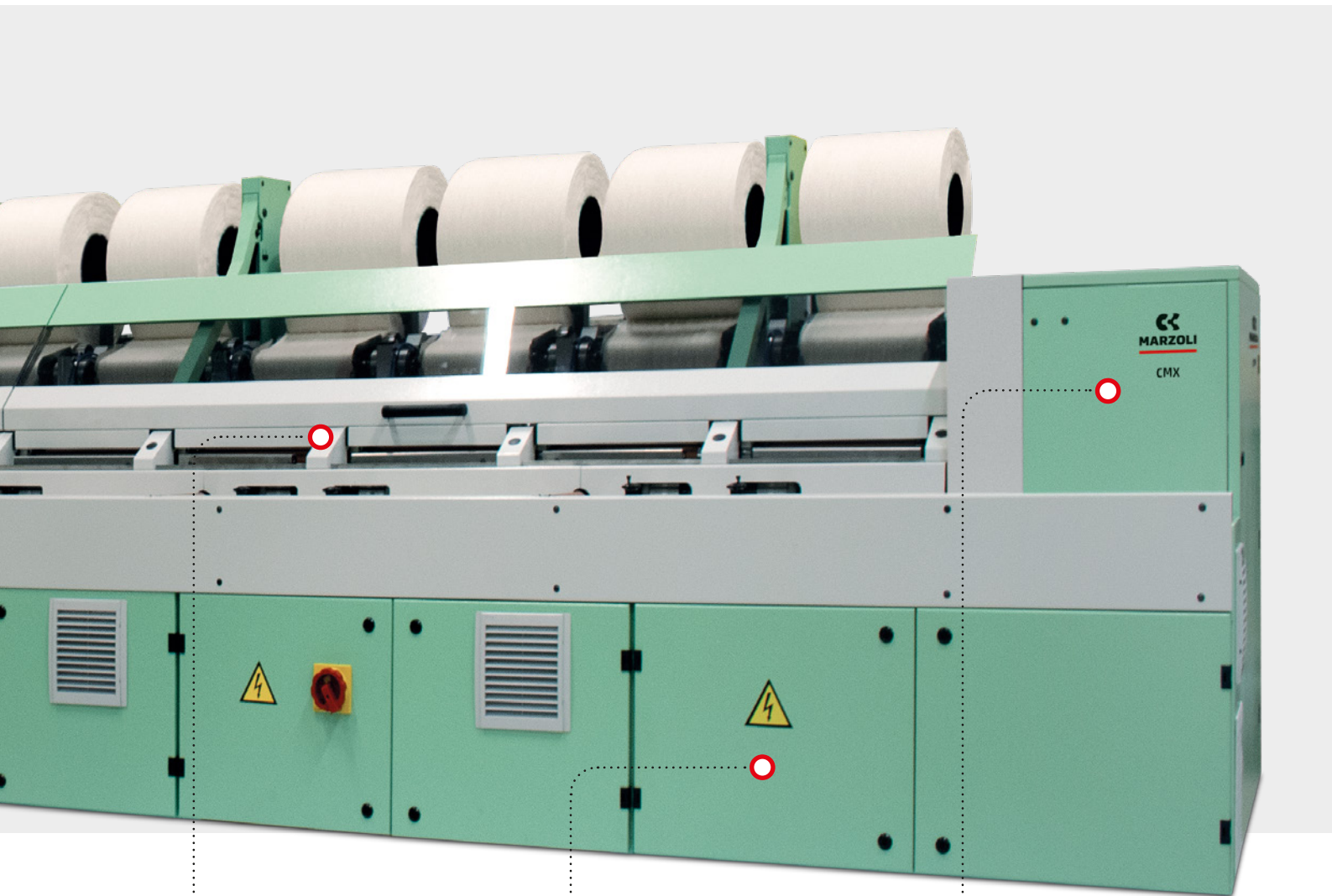

• New piecing of the web with electronic setting

• Up to 20% energy savings (kW/kg) on the combing section

• New simpler drive with higher reliability and easier maintenance

Fully automatic transport

The fully automatic transport works as follows:

1. During the doffing cycle of the lap winder the laps are loaded on a special conveyor belt which carries the laps underneath the rail of an overhead crane.
2. Meanwhile the overhead crane collects the empty tubes from a CM7 comber that has undertaken automatic lap piecing.
3. The overhead crane collects eight full laps from the conveyor belt and automatically positions them on the spare laps pallet of the CM7 comber.

Although the fully automatic transport system requires the installation of additional components

(overhead light crane, conveyor belt and, it also discloses several advantages:

- No operator effort in an activity which has traditionally been labor intensive.
- No waiting times at the combers.
- Higher productivity.

The advantages of the fully automatic transport solution become more and more relevant as the spinning mill becomes bigger. Moreover, as the number of combers grow, the investment becomes more convenient because the cost of the overhead crane and of the conveyor belt spreads on a higher number of machines.

CONTROL AND MANAGEMENT

Simple and intuitive operator interface thanks to optimized graphics. The positioning of the various conveyors and lifting devices is obtained through optical sensors and laser beam. Flexible program

for managing the collection and deposit of rolls in the various machine blocks to manage the operation of the automatic transport even during the scheduled or extraordinary maintenance of the machines.

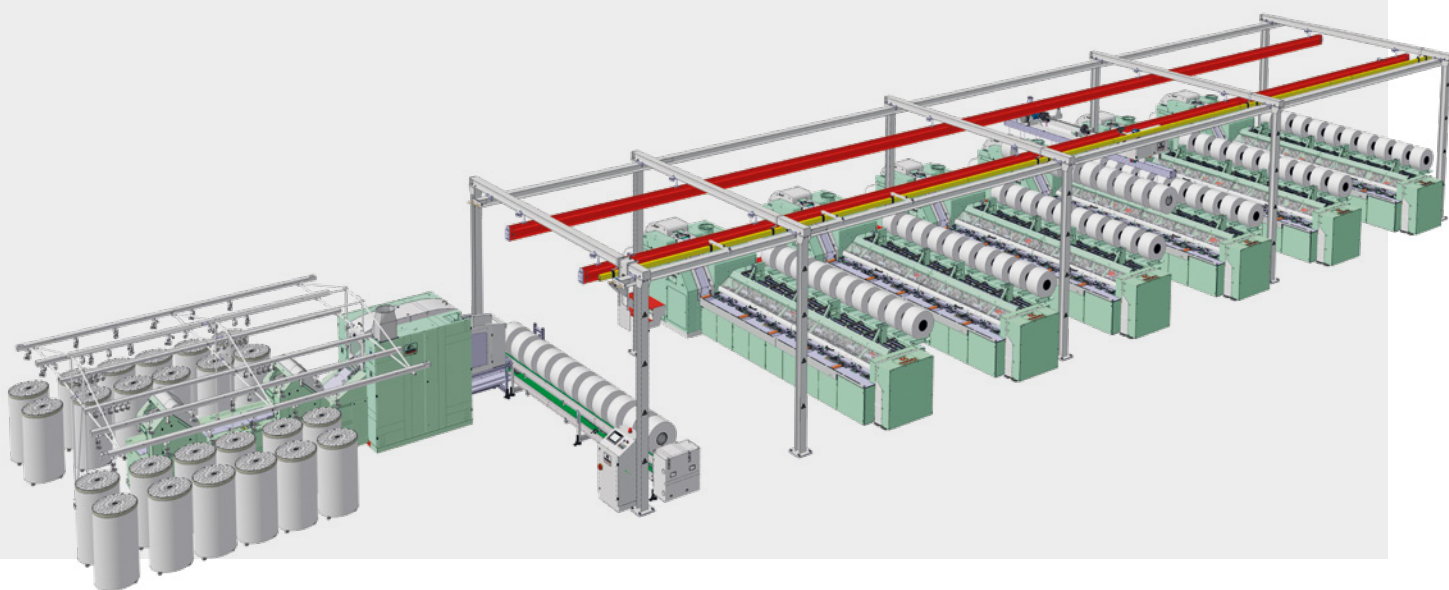

TECHNICAL DATA

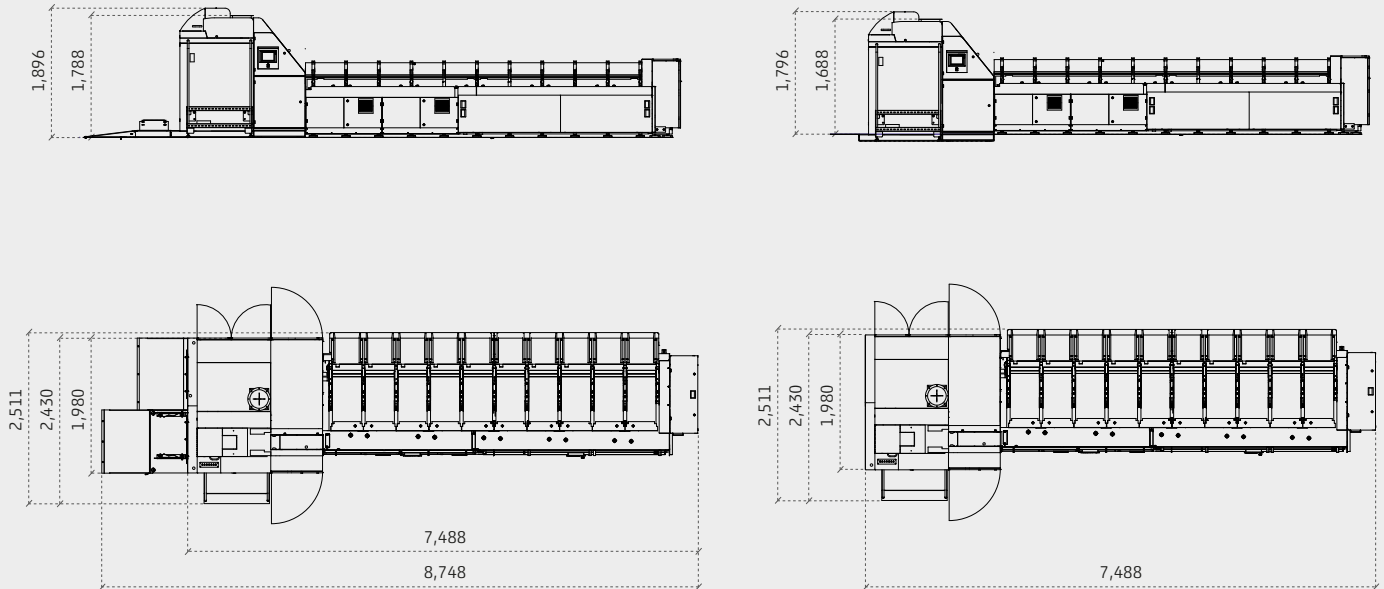

CMX

Combing elements:	90°-112°
· circular combs	23-26-29-32
· selfcleaning top combs tips per cm	
Cans dimensions:	24"
· diameter	48" (with castors)
· height	
Total installed power	14 kW
Processed fibers	Cotton 1 1/16" - 2"
Lap weight	Up to 80 ktex (up to 80 g/m)
Feed	forward/backward
Noil	8% - 25%
Mechanical speed	Up to 600 nips/min
Production	Up to 115 kg/h
Feeding rate	4.7 - 4.9 - 5.2 - 5.5 - 5.9 - 6.3

Lap transport system

Belt transfer	Independent belt transfer controlled by 2 gear motors Transfer speed min 6 m/min - max 12 m/min
Carriage transfer	Transfer unit via friction wheels Transfer speed min 5 m/min - max 20 m/min
Lifting	Orthogonal gear motor Lifting speed min 0.8 m/min - max 8 m/min
Coupling / uncoupling - Rolls / laps	Electric actuator (motor DC 24V) Rated speed without load 33 mm/s
Sensors	Infrared LED optical transmitter 3 Mbit/s up to 180 m Red laser distance detector up to 100 m reading tolerance of ±2 mm

Marzoli Machines Textile S.r.l.
Via Sant'Alberto, 10
25036 Palazzolo sull'Oglio (BS)
Italy
Tel. +39 030 73091
sales@marzoli.it

