

Progress check

Year 6

Mathematics

Paper 2: reasoning and problem solving

First name						
Middle name						
Last name						
Date of birth	Day		Month		Year	
Teacher						

Published Spring 2018

These assessments have been designed by White Rose Maths.
For more information, please visit www.whiterosemaths.com



[BLANK PAGE]

Please do not write on this page.

Instructions

You **may not** use a calculator to answer any questions in this test.

Questions and answers

You have **40 minutes** to complete this test.

Follow the instructions for each question.

Work as quickly and as carefully as you can.

If you need to do working out, you can use the space around the question.

Some questions have a method box like this:

Show your method

For these questions you may get a mark for showing your method.

If you cannot do one of the questions, **go on to the next one.**

You can come back to it later, if you have time.

If you finish before the end, **go back and check your work.**

Marks

The number under each line at the side of the page tells you the maximum number of marks for each question.

1

Shade $\frac{1}{10}$ of the shape.

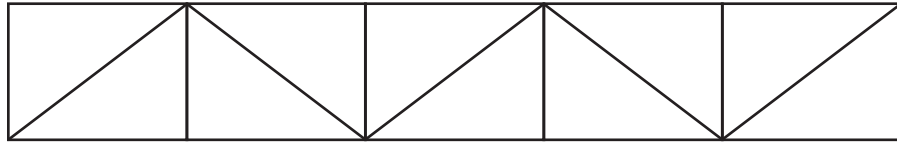

1 mark

Circle the number which is equivalent to $\frac{1}{10}$

0.1

0.01

1

10

1 mark

Complete the sequences.

$$\frac{29}{100}, \frac{30}{100}, \frac{31}{100}, \boxed{\phantom{\frac{\quad}{\quad}}}, \boxed{\phantom{\frac{\quad}{\quad}}}, \boxed{\phantom{\frac{\quad}{\quad}}}$$

1 mark

2

Sophie makes a number on a place value grid.

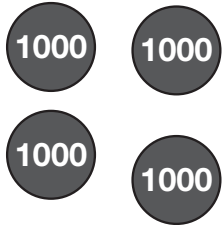
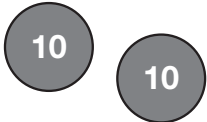
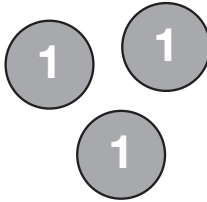
Thousands	Hundreds	Tens	Ones
			

What is Sophie's number?

1 mark

Sophie adds 40 to her number.

What is her new number?

1 mark

3

Class 6 have some fruit.

For every 2 apples they have 3 bananas.

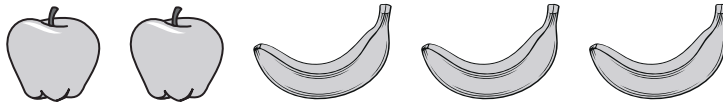

They have 10 apples.

How many bananas do they have?

1 mark

4

The numbers in the sequence increase by the same amount each time.

Complete the missing numbers.

	2		12	17	22
--	---	--	----	----	----

2 marks

5

Find the area of the triangle.

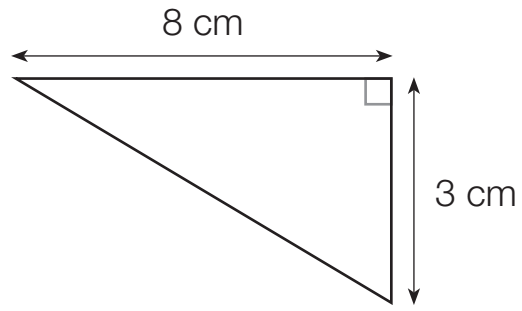

cm²

1 mark

6

Four children take part in a throwing event.

Their distances are recorded in the table.

Name	Distance (metres)
Jake	13.54
Briony	21.54
Rehan	20.69
Tom	18.21

What is the difference between the longest throw and the shortest throw?

Show your method

A large grid for showing the method to solve the problem. A small box with the letter 'm' is provided for the answer.

1 mark

Write down the name of the child whose distance rounds to 21 metres to the nearest metre.

A box for writing the name of the child whose distance rounds to 21 metres to the nearest metre.

1 mark

7

Laura is thinking of a number.

She multiplies her number by 2 and then subtracts 6

She divides the result by 11

Her answer is 4

What was her starting number?

1 mark

8

Write each number in its correct place on the diagram.

2

24

48

12

13

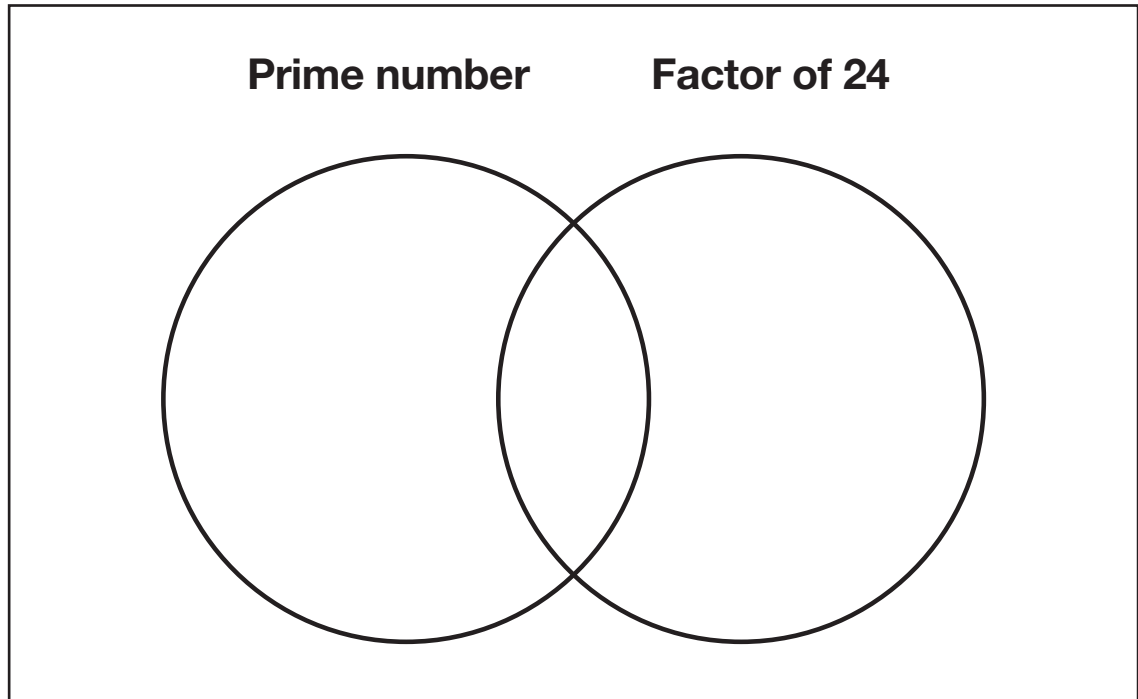

2 marks

9

Write 0.25 as a fraction.

1 mark

Amy says that 0.75 is smaller than $\frac{7}{8}$

Explain why Amy is correct.

1 mark

10

The mass of a box containing 6 tins of beans is 7.5 kg.



When 2 tins of beans are removed, the box weighs 5.1 kg.

What is the mass of the empty box?

Show
your
method

A large rectangular grid for showing the method. The grid is composed of small squares. On the left side, there is a bracketed area containing the text "Show your method". In the bottom right corner of the grid, there is a rectangular box containing the text "kg".

3 marks

11

Martin is running in a race.

He runs $\frac{2}{3}$ of the total distance of the race.

He has 18 km left to run.

What is the total distance of the race?

Show
your
method

A large grid for showing the method to solve the problem. A small box on the right side of the grid contains the text "km".

2 marks

12

Here are the ingredients needed to make **8 pancakes**.

Ingredients

Sugar 150 g

Butter 275 g

Eggs..... 2

Flour..... 400 g

How much more flour than sugar is used?

Show
your
method

A large grid for showing the method. A box on the right side of the grid contains the letter 'g'.

1 mark

How much butter is needed for 24 pancakes?

Show
your
method

A large grid for showing the method. A box on the right side of the grid contains the letter 'g'.

2 marks

13

Calculate the area of the shape.

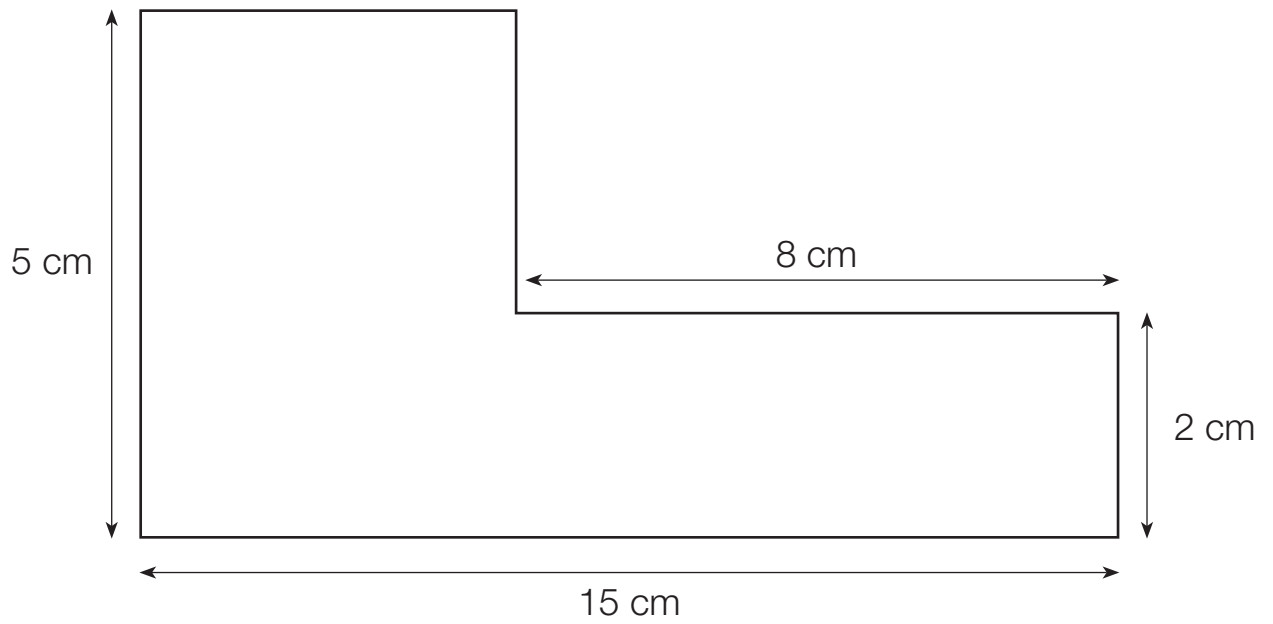

Show
your
method

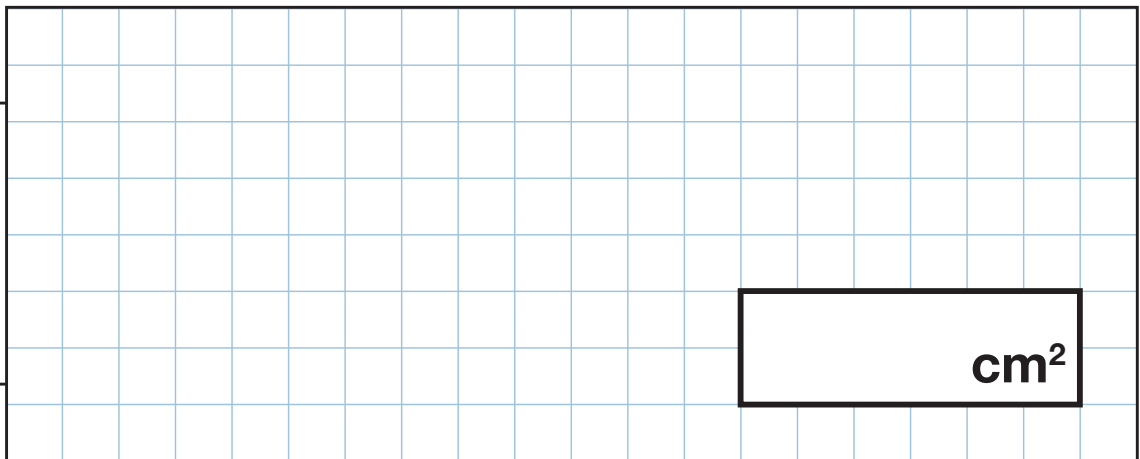

2 marks

14If $n = 20$ What is the value of $3n + 2$?

1 mark

$$4p + 2 = 14$$

Find the value of p .

1 mark

15

Tilly needs 12 apples.

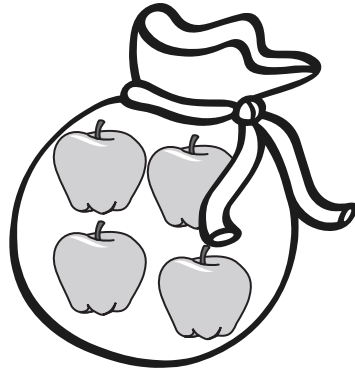

Bag of 4 apples
£1.32



Single apple
40p

How much cheaper is it to buy 12 apples in bags rather than 12 single apples?

Show
your
method

A large grid of 20 columns and 15 rows. On the right side of the grid, there is a rectangular box with the letter 'p' inside it, indicating where the answer should be written.

2 marks

16

Find the volume of the cuboid.

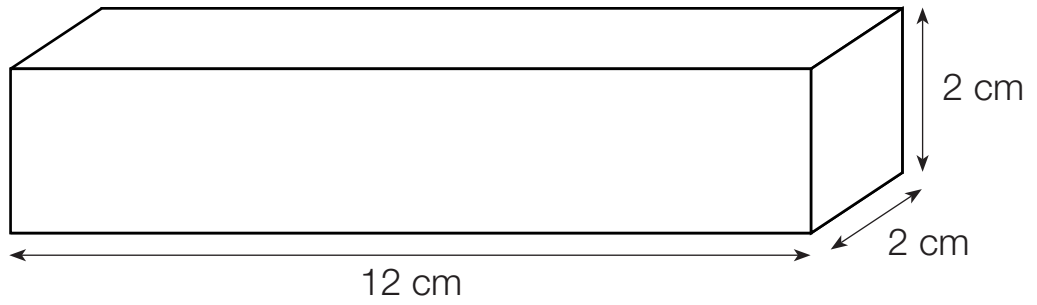

cm³

1 mark

17

Find $\frac{3}{4}$ of 5 km.

Give your answer in metres.

Show
your
method

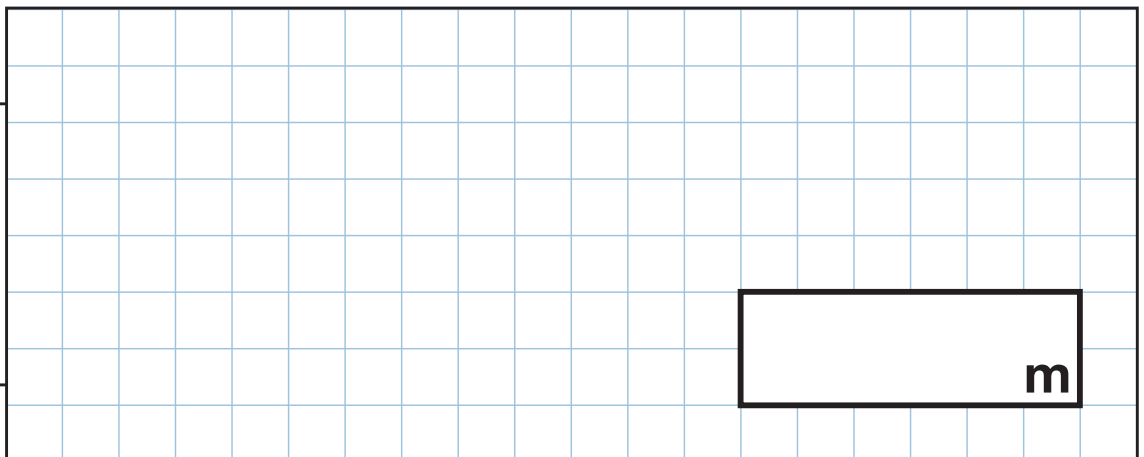

2 marks

18

Bilal and Charlie have some sweets.

Bilal has 4 times as many sweets as Charlie.

Bilal gives Charlie 15 of his sweets and now they have the same amount.

How many sweets do they have altogether?

Show
your
method

The grid is 20 units wide and 10 units high. A small rectangular box with a black border is positioned on the grid, containing the word "sweets" in bold black text. The box is approximately 4 units wide and 2 units high, starting from the 15th vertical line and the 6th horizontal line from the top-left corner.

2 marks

END OF TEST

[BLANK PAGE]

Please do not write on this page.