

millboard

Live. Life. Outside.



—
Installation Guide for
Millboard Envello
Cladding

Contents page

Easily find your way around the Millboard Envello Cladding Cladding installation guide.

- 1. Intended use (P.3)
 - 2. Limitations (P.3)
 - 3. Storage & handling (P.4)
 - 4. Fire Performance (P.4)
 - 5. Tools & PPE required (P.5)
 - 6. Board options and colours (P.6)
 - 7. Trims, fixings, accessories (P.7)
 - 8. Colour Characteristics (P.11)
 - 9. Cutting/machining (P.11)
 - 10. Ventilation and breather membrane (P.12)
 - 11. Cladding support batten system (P.12)
 - 12. Installing Millboard Envello Cladding Cladding (P.14)
 - 12a. Corners of the building - Shadow Line
 - 12b. Corners of the building - Board & Batten
 - 12c. Installing Starter Trims
 - 12d. Fixings
 - 12e. Joining Boards
 - 12f. Joining Corner Profiles
 - 12g. Details around windows and doors - Shadow Line
 - 12h. Details around windows and doors - Board & Batten
 - 13. After care (P.16)
- Drawings (P.17 - 32):**
- 001-042 - Shadow Line used horizontally
 - 101-142 - Shadow Line used vertically
 - 201-243 - Board & Batten used vertically
 - 301-342 - Board & Batten used horizontally



General overview

1) Intended Use

1a) Millboard Envello Cladding Cladding has been designed for beauty, longevity and ease of installation on residential and low-rise buildings. However, to ensure the best installation and long-term performance, we recommend that a professional tradesperson carries out the installation.

1b) Millboard recommend that all cladding designs are approved by a licensed architect or engineer prior to installation. It is the property owner's responsibility to make sure that your plans meet any relevant local building regulations before the installation begins. Millboard Envello Cladding Cladding must be supported by a suitable substructure that is in accordance with building regulations.

1c) Millboard Envello Cladding is a rainscreen cladding system which can be described as 'A wall comprising an outer skin of cladding boards and an airtight insulated backing wall separated by a ventilated cavity. Some water may penetrate into the cavity but the rainscreen cladding is intended to provide protection from direct rain. Therefore, a well ventilated, free draining cavity should always be included in the detailed design.

1d) It is not recommended to use Millboard Envello Cladding in structural applications. Millboard Envello Cladding would need to be fixed to a structural frame of battens, either made from Plas-Pro or timber.

2) Limitations

2a) This installation guide is not exhaustive as the responsibility for design lies with the specifier or responsible party for the project, to ensure the final design meets the requirements of the intended application and Building regulations.

2b) For designs outside the scope of this installation guide, specific design must be undertaken by an architect or designer. If in doubt, we would strongly recommend contacting Millboard pre-design stage to arrive at a suitable, robust, efficient solution and to avoid disappointment.

2c) It is the responsibility of designers, installers, and owners to ensure that the information in this manual is current, by checking with Millboard or referring to our website. As new technology is introduced or industry standards are altered, Millboard reserves the right to alter existing specifications and remove products without notice.

Go to our website on: www.millboard.co.uk

2d) The use of this manual: does not guarantee acceptance or accreditation of a design, material or building solution by any entity authorised to do so under law; does not mean that a design, material or building solution

complies with the building regulation; or does not absolve the user from complying with any local, or Government legal requirements.

3. Storage and Handling

3a) Millboard Envello Cladding Cladding boards should always be stored on a flat surface or level bearers a maximum of 400mm apart and stacked face-to-face, not back-to-face. The External and Internal Corner profiles should be fully supported along their length.

3b) When loading and unloading by hand, make sure that both ends are lifted on the edge to avoid permanent deformation and/or damage to the boards. They should only be lifted off the stack, and not dragged as this could cause abrasion or marking on the surface.

3c) Only move the pallet if the boards are safely strapped to it.

3d) Wear gloves and long sleeves when handling the boards and take care when lifting them. We recommend that two people carry the boards, they should be carried on their side for increased rigidity

3e) We advise that the cladding planks are stored on site at least 72 hours before installation, to allow the boards to climatize.

Millboard cannot be held responsible for damage caused by improper storage and handling of the product.

4. Fire Performance

4a) Millboard Envello Cladding is not a non-combustible product (not A1 or A2) so should not be used as cladding to buildings with a storey at least 18m above ground level in England (11m for buildings in Scotland).

4b) For buildings with storeys less than 18m (11m) above ground level Millboard Envello Cladding may be used, however the responsibility for the cladding's suitability in the required location is by others (e.g. client, building control, etc). The fire performance of Millboard Envello Cladding can be compared with that of timber.

4c) For further guidance on fire safety, please refer to the latest government documentation which can be found on : <https://www.gov.uk/government/publications/fire-safety-approved-document-b>

5. Tools & PPE required

The tools and PPE you will need to install the Millboard Envello Cladding Cladding product.



Mitre saw/jigsaw/ handsaw

Millboard Envello Cladding products can be cut with standard wood cutting tools (i.e. mitre saw, jigsaw, handsaw). We recommend using a carbon-tipped saw blade. An aluminium cutting blade should be used for the metal trims.



Personal Protective Equipment

When handling Millboard products, it is advised to wear long sleeves and gloves. When cutting products it is advised to wear a FFP3 dustmask, ear defenders and safety glasses.



Tool set

Standard carpentry tools will be needed to complete the installation, including: tape measure, a pencil, set square, planer, stanley knife, surform and a drill bit set.



Power drill and driver

Standard power drill drivers can be used to fix the cladding products. Impact drivers are not recommended to be used when using the Durafix fixings.



Spirit level

A spirit level is used to ensure that the battens are upright and the starter trims are level.



Laser level/line

If available, a laser level can be used to ensure the starter trims are installed level.

6. Envello Cladding board options and colours

6a) Envello Shadow Line Cladding boards

- Can be used Horizontally or Vertically
- 200x18x3600mm
- Actual 'installed width' 181mm
- Boards needed per sqm 1.53
- Colours:
 - Smoked Oak - MCG360D
 - Antique Oak - MCG360A
 - Golden Oak - MCG360G
 - Burnt Cedar - MCG360R

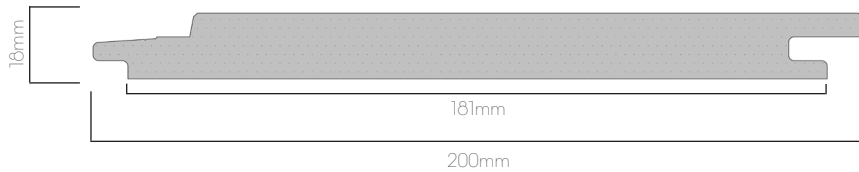

6b) Envello Board & Batten Cladding boards

- Can be used horizontally or vertically
- 200x28x3200mm
- Actual 'installed width' 181mm
- Boards needed per sqm 1.73
- Colours:
 - Smoked Oak - MCB320D
 - Antique Oak - MCB320A
 - Golden Oak - MCB320G
 - Burnt Cedar - MCB320R

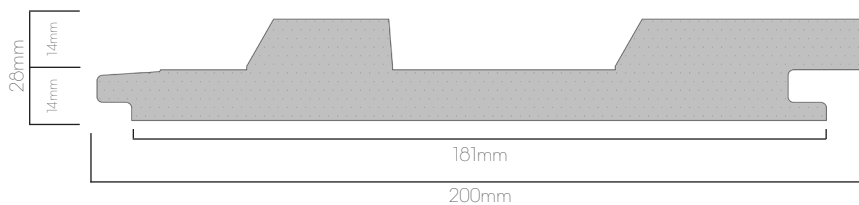

7. Trims, Fixings, Accessories

7a) External Corner Profile

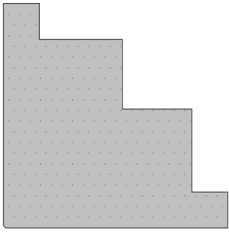

- 50 x 50 x 3050mm
- Colours: Smoked Oak - MCPE50D
Antique Oak - MCPE50A
Golden Oak - MCPE50G
Burnt Cedar - MCPE50R
- Profile used with the Shadow Line boards to finish off the external corner of a building, fixed with the perforated closure and 20mm fixings.

7b) Internal Corner Profile

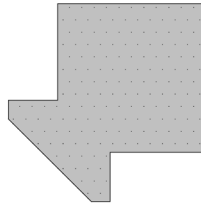

- 38 x 38 x 3050mm
- Colours: Smoked Oak - MCPH38D
Antique Oak - MCPH38A
Golden Oak - MCPH38G
Burnt Cedar - MCPH38R
- Profile used with the Shadow Line boards to finish off the internal corner of a building, fixed with the perforated closure and 20mm fixings.

7c) Horizontal Starter Trim J

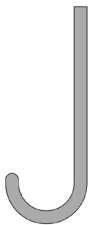

- 25 x 10 x 2500mm
- Product code: GT250J
- Aluminium trim used to start the cladding at the bottom, when the cladding is installed horizontally, fixed with 20mm fixings

7d) Vertical Starter Trim L



- 25 x 13 x 2500mm
- Product code: GT250L
- Aluminium trim used to start the cladding at the bottom, when the cladding is installed vertically, fixed with the 20mm fixings

7e) Perforated Closure



- 50 x 25 x 3000mm
- Product code: GP300L
- Aluminium closure used to prevent insects/rodents getting into the ventilated cavity behind the boards, but allowing airflow. Fixed at the bottom of the cladding with the starter trim, also at the top on its own, as well as with the corner profiles - all fixed with the 20mm fixings.

7g) Cladding Accessories Fixings



- 3.5 x 20mm
- Box of 250
- Product code: FC20P250
- A2 Stainless Steel fixings used to fix the corner profiles, starter trims and perforated closures

7f) Cladding Board Fixings



- 3.5 x 30mm
- Box of 250
- Product code: FC30P250
- A2 Stainless Steel fixings used to fix the Envello cladding boards on to the battens, fixing through the tongue of the boards

7h) Plas-Pro Cladding Batten



- 25 x 50 x 3000mm
- Colour: Black
- Product code: P0205B300
- Recycled plastic battens used to fix all of the components to, including cladding boards, starter trims, corner profiles and perforated closures.

7i) Millboard Fascia Boards



- 146 x 16 x 3200mm
- Colour:
Smoked Oak - MFN320D
Antique Oak - MFN320A
Golden Oak - MFN320G
Burnt Cedar - MFN320R
- Fascias may be required for window/
door reveals or soffits, fixed with 35mm
Durafix fixings

7k) Durafix 4.5 x 35mm Fixings



- 4.5 x 35mm
- Box of 100
- Product code: FT35P100
- The Durafix 35mm A2 stainless
steel fixings may be required for fixing the
cladding boards where a fixing through the
tongue isn't possible, also used for fixing
fascia boards.

7j) Millboard Square Edging



- 50 x 32 x 3200mm
- Colour:
Smoked Oak - MEUN32D
Antique Oak - MEUN32A
Golden Oak - MEUN32G
Burnt Cedar - MEUN32R
- Square edging may be used as a
corner detail - especially with the Board &
Batten, fixed using the Durafix 45mm fixings

7l) Durafix 4.5 x 45mm Fixings



- 4.5 x 45mm
- Box of 250
- Product code: FT45P250
- The Durafix 45mm A2 stainless steel
fixings may be required for fixing the square
edging or the Board & Batten through the
face.

7m) Plas-Pro 25 x 100mm



- 25 x 100 x 3000mm
- Colour: Black
- Product code: P0210B300
- Plas-Pro 25 x 100mm may be required on the corners of buildings to provide a greater fixing point for the cladding boards.

7n) Touch-up Coating



- 500ml
- Colour:
 - Smoked Oak - AP500D
 - Antique Oak - AP500A
 - Golden Oak - AP500G
 - Burnt Cedar - AP500R
- Touch-up used for coating any exposed cuts or edges on the Millboard Envello Cladding boards, edging profiles, square edge or fascia boards.

Additional items that may be required (supplied by others):

- Flashing/drip profiles (around windows/doors/openings or at the bottom of the cladding)
- Fixings for installing the battens on to the structure (suitable type of fixing for the structure and battens used)
- Screws for fixing the battens together (suitable type of screw for the location and battens used)
- Clear low-modulus silicone sealant (to help prevent water penetrating through the system)
- Silicone spray (for when using the Durafix fixings)
- Polyurethane wood glue (used when mitring the boards)
- Super glue (used when mitring the boards)

8. Colour Characteristics

8a) Millboard Envello Cladding has been designed to replicate the natural variances of timber and is manufactured to have tonal variance in the colour.

8b) Buying all the Millboard you need at the same time should help to ensure that the colour is consistent, if you do have multiple batches then it is best to mix the boards, to create an effective, subtle blend.

8c) Antique Oak boasts more tonal variation per individual board than any of the other colours in the Millboard range.

8d) As with all products exposed to the Sunlight (UV), Millboard will naturally weather and tone down over time. Slight yellowing especially in the deeper grain areas and loss of gloss is perfectly normal and will not affect the performance of the products.

8e) Millboard takes great care ensuring the performance of its products maintain the timber effect we seek to portray, and we believe at every stage of its life Millboard truly reflects this more than any other timber alternative product, due to being moulded from real timber and the hand coloured process.

8f) On delivery if you find the colour unacceptable or believe them to be defective in any way, please contact us. If there are any foreseen issues with the boards, this should be highlighted with Millboard before installing.

9. Cutting

9a) Envello products can be cut with standard wood cutting tools (i.e. mitre saw, jigsaw, handsaw), we recommend a carbon-tipped saw blade. An aluminium cutting blade should be used for the metal trims

9b) For cutting Plas-Pro, we recommend using a carbon-tipped ripping/multi-purpose blade.

9c) Dispose of board off-cuts by disposing as general waste or sending to a municipal incinerator for energy replenishment, don't burn them at home.

9d) When cutting the boards, wear an FFP3 dust mask, safety glasses, long sleeves and protective gloves.

9e) A dust bag or vacuum must be used on mitre saws.

9f) Make sure that the boards are adequately supported when cutting. Boards can be cut face-up or face-down.

9g) When the board is cut, Touch-up Coating should be used if the cut will be visible and exposed to UV.

Tip:
If there is a breeze/wind when cutting the boards, locate the saw up wind so that excess dust is blown away from the operator.

10. Preparation and Battening

10a) Ventilation for the control of moisture is a key element in the design and construction of cladding. It is a requirement not an option and should not be overlooked. A continuous airflow from bottom to top is vital for long term durability.

10b) As a rainscreen system it assumes that the cladding will always be subject to some moisture penetration, therefore the surface that the battens will be fixed to needs to provide the waterproof finish.

10c) Although a breather membrane is necessary for a timber frame, it may not be required on a masonry cavity wall.

10d) Where the substrate is an existing building with solid walls (i.e. no cavity), to prevent water penetration the wall should be given a waterproof coating or better still a breathable membrane should be fitted.

10e) Whatever system is used a minimum 19mm open cavity should always be provided behind the cladding and a minimum 10mm continuous gap left at the top and bottom of the system for full ventilation to dissipate any condensation or drainage at the bottom.

10f) Consideration regarding insect and rodent invasion should also be considered and a perforated closure should be used to counter these threats where there is the required air gap, whilst still maintaining the required air flow.

11. Cladding support batten

11a) The time and care taken on setting/fixing the support system right will be reflected in the finished result. Time taken to upright corners and straighten battens on undulating walls will make the installation of the cladding a far easier installation and a superior finished result.

11b) Millboard 25x50mm Plas-Pro Cladding Battens are recommended to be used for a non-rot solution, as some moisture may penetrate through the boards to the battens.

11c) Suitable treated timber battens can be used as an alternative, we would recommend putting a strip of DPC, joist tape or EPDM on to the front of the timber battens that the boards will be attached to.

11d) Batten size requirements:
 - Plas-Pro 25x50x3000mm Cladding Batten (main Cladding batten) or suitable treated timber equivalent (minimum size of 19x38mm)
 - Plas-Pro 25x100x3000mm Support (used for corners) or suitable treated timber equivalent

11e) For the different cladding profiles, the maximum support spacing is shown in table 1. For areas of high wind loading exceeding 1.0kN/m², severe weather exposure or where exceptional impact loading requirements are anticipated (i.e. low-level applications near pedestrian access, schools, leisure facilities etc.) batten support spacing should be

reduced to increase the board stiffness, see chart below.

Table 1:

Product	Maximum Support Centres	Support Centres for high load areas
Shadow Line 18mm	400mm	300mm
Board & Batten 28mm	600mm	400mm

11f) There should always be battens attached to the wall vertically to allow clear ventilation behind the boards, if the cladding is set horizontally the boards would be fixed directly to these battens at the centres shown on table 1. This layout can be seen on drawings 006 & 306.

11g) When installing the boards horizontally we would recommend that the 25x100mm Plas-Pro profile is used on the corners, to provide more stability at these points. This can be seen on drawings 040-042 & 340-341

11h) If the boards are to be set vertically then horizontal battens should be fixed to the vertical battens at the centres shown on table 1, if Plas-Pro 25x50mm battens are being used these should be supported at 400mm centres. This layout can be seen on drawings 106 & 206

11i) The batten layout around windows/doors/soffits should be that it allows the continuous airflow behind the boards, a 10mm gap should be left between the underside of the windowsills or soffits and at the head of windows/doors. This can be seen on drawings X03, X04, X07, X20, X22 & X24. The battens

up the side of the window/doors should be flush with the opening; all vertical battens should be upright.

11j) The perforated closure should be used in all areas where there is an opening to the ventilated cavity, to prevent insects entering the cavity. The Millboard Perforated closure suits batten sizes of 25 or 50mm, if battens different to these sizes are used then perforated closures or flymesh supplied by others should be used.

11k) Determine at what height the cladding is to start at. If it is starting at ground level, it should start at a minimum of 150mm above finished ground level, as shown in drawings X01. With a laser line or level, mark up a level line around the building or along the wall that is to be clad. This line will be the bottom of the batten/s.

11l) Battens should be fixed to the structural wall using suitable external grade fixings, for fixing to a timber frame the battens should preferably be fixed into the timber studs of the frame. The battens should be fixed

upright, packers may be needed for this if the wall is undulating.

11m) The Plas-Pro battens should have a minimum 10mm gap between the end butt joints, as well as being predrilled with an oversized hole to allow for potential linear expansion.

11n) It is best for the perforated closure to be held between the back of the battens and the wall, as shown in drawings X01-X04, X20 & X22. This should be taken in to consideration when fixing the battens, alternatively they can be fixed to the front of the battens using the 20mm Accessories Screw.

12. Installing Millboard Envello Cladding Cladding

12a - Corners of the building - Shadow Line

12a.i) When using the Shadow Line Board the External and Internal Corner Profiles can be used. These allow the boards to butt up to it and hide any potential shrinkage. These are shown on drawings – 040, 041, 140 & 141.

12a.ii) If the External Corner profile or Internal Corner profile are being used with the Shadow Line boards on the edges of the buildings, these should be fitted first before the starter trims.

12a.iii) The perforated closure is fitted to the back of the External or Internal Corner profile using the 20mm Accessories Screw at 200mm centres, these are then fixed to the battens on the corner.

12a.iv) These are best to be fixed as shown, however they can be fixed with the Durafix fixing through the face but the fixing holes will be visible.

12a.v) Alternatively, the boards can be mitred to create the external corner, this would also be applicable if the corner is anything other than 90 degrees. This can be seen in drawing 042 & 142.

12a.vi) When using the boards horizontally it is best to use the same board around the corner so that the wood grain, colour tone, and profile match.

Tip for mitre joints:
Mitre and dry fit the boards to make sure the joint fits well, apply polyurethane wood glue to the core of the boards and superglue to the lastane surface. Bring the joint together with the lastane front edge touching together first, then close the back of the joint and drop into place. If any PU glue bubbles out of the joint, wait until it is semi-dry and remove. Touch-up Coating can be used on any small imperfections on this joint.

12b - Corners of the building - Board & Batten

12b.i) When using the Board & Batten boards the Square Edge Profile can be used for the external corners, the internal corners would be the boards butted up to the square edge – shown on drawings 240, 241, 340 & 341.

12b.ii) When the boards are used vertically it is best to wait until the second to last board is fixed before determining which way is best to use the Square Edge. If the back of the square edge will be visible then this will need to be coated in Touch-up Coating.

12b.iii) If a Board & Batten board is cut along its length then this could be glued to the back of the square edge with PU wood glue and superglue. The square edging and Board & Batten boards will need to be fixed through the face using Durafix® fixings in this instance.

12b.iv) Alternatively fascia boards can be mitred (as seen on drawing 242), or the boards can be mitred round the corner (as shown on drawing 342) - all mitres completed following the tip on page 14. The fascia boards and Board & Batten boards will need to be fixed through the face using Durafix fixings in this instance.

12c - Installing Starter trims

12c.i) The Starter trims will be fitted to the bottom of the battens, if the cladding boards will be installed horizontally the Horizontal Starter Trim should be used. If they are installed vertically the Vertical Starter Trim should be used.

12c.ii) It is important that these trims are installed level so that the boards running off these trims are level.

12c.iii) These starter trims are fixed to the battens using the 20mm Accessories screws with the heads countersunk into the trim. Set out as shown on drawings X01 & X02.

12d - Fixings

12d.i) The Millboard Envello Cladding boards should be fixed through the tongue with the 3.5x30mm cladding screws, with one fixing per batten intersection.

12d.ii) The fixings should be inserted through

the fixing guide groove on the tongue and angled down slightly, the head should sit flush with the surface.

12d.iii) The fixings do not need to be predrilled or countersunk, the boards will allow the head to countersink slightly.

Tip for Durafix fixings:
When using the Durafix fixings, the fixings should firstly be coated in silicone spray. When screwing in, push firmly on the screw whilst applying pressure to the board, finishing the screw head 5mm below the boards surface. This should leave a minimal witness mark.

12e - Joining boards

12e.i) As the boards are manufactured through a moulding process we recommend that all ends are cut before they're installed.

12e.ii) If the boards are being used horizontally we recommend that they are squared off with a slight back cut, silicone sealant should be used at the back of the boards when they are butted up together – as shown on drawing 005 & 305.

12e.iii) If the boards are being used vertically we recommend that the boards are joined with a 20 degree scarf joint with the top overlapping the bottom, the bottom cut should be painted in Touch-up Coating. Silicone sealant should be used at the back of the boards when the top profile is put over the lower profile – as shown on drawing 105 & 205.

12e.iv) As Millboard is made from a

resin mineral composition it is stable in comparison to timber or composites based on timber, the amount of movement that is acceptable is up to 0.2%.

12f - Joining corner profiles

When joining two corner profiles together, these should be joined on a 20 degree scarf joint. The bottom cut should be painted in Touch-up Coating. Silicone sealant should be used at the back when the profiles are joined on a Perforated Closure.

12g - Details around windows and doors - Shadow Line

12g.i) Around windows and door openings we would recommend using the fascia boards to cover the reveals with the cladding boards butted up to the back of them. The fascia boards will need to be fixed with the Durafix fixings through the face.

12g.ii) The back edge of the fascia boards will need to be painted in Touch-up Coating if they will be visible, silicone sealant will be needed between the cladding boards and fascia boards and between the fascia boards and the window to reduce the risk of water penetrating behind. Shown on drawings 020, 021, 120 & 121.

12g.iii) Alternatively the boards can be mitred and run back into the window reveal – shown on drawings 022, 023, 122 & 123.

12g.iv) Care should be taken not to block the air gap at the top of the reveal and under the sill, leaving a clear 10mm gap.

12h - Details around windows and doors – Board & Batten

12h.i) The square edge can be used as a

detail around windows and doors, with the fascia boards lining the reveals, all fixed using the Durafix fixings – shown on drawings 220, 221, 320 & 321.

12h.ii) It is best to install the cladding boards around the opening first and fit the square edge and fascia boards after, when the cladding boards are cut to the opening there should be enough gap around the opening to allow for the square edge to fit to the battens as well.

13. After care

13a) If the boards become dirty during installation, they should be cleaned as soon as possible using warm soapy water and a brush or pressure washer.

13b) Pressure washers can be used on Millboard Envello Cladding, with a PSI of no greater than 2000.

A fan tip should be used with a 40 to 60 degree spread, keeping the head 250-300mm away from the surface. Test in an inconspicuous area first - direct, prolonged contact could damage the surface of the boards

13d) Stubborn marks may be removed with a range of different cleaners depending on the mark. Please contact us for more information on 02476 439 943.

Shadow Line used horizontally

001.

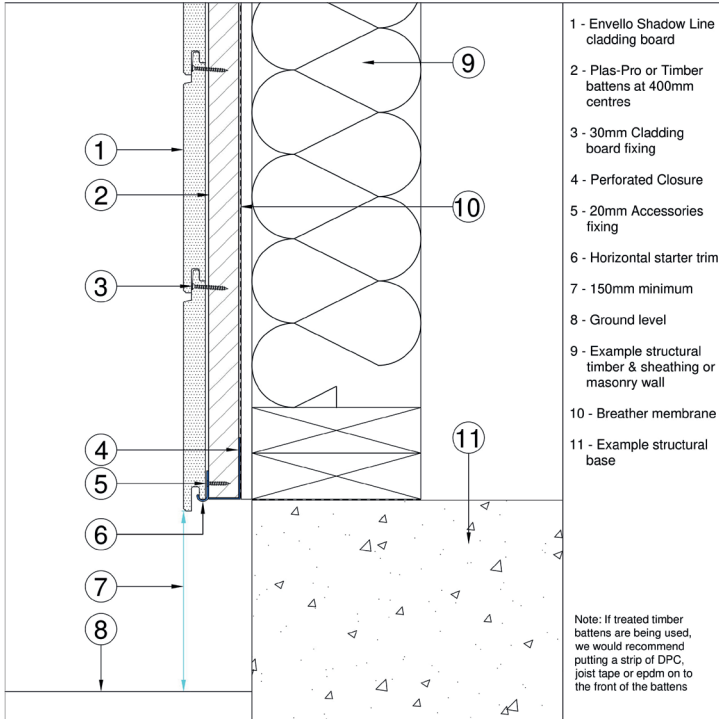

002.

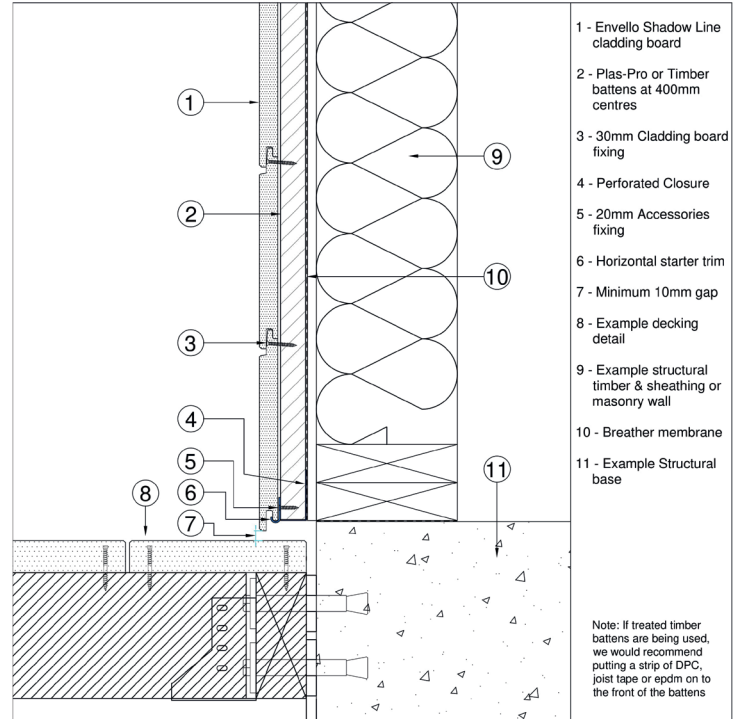

003.

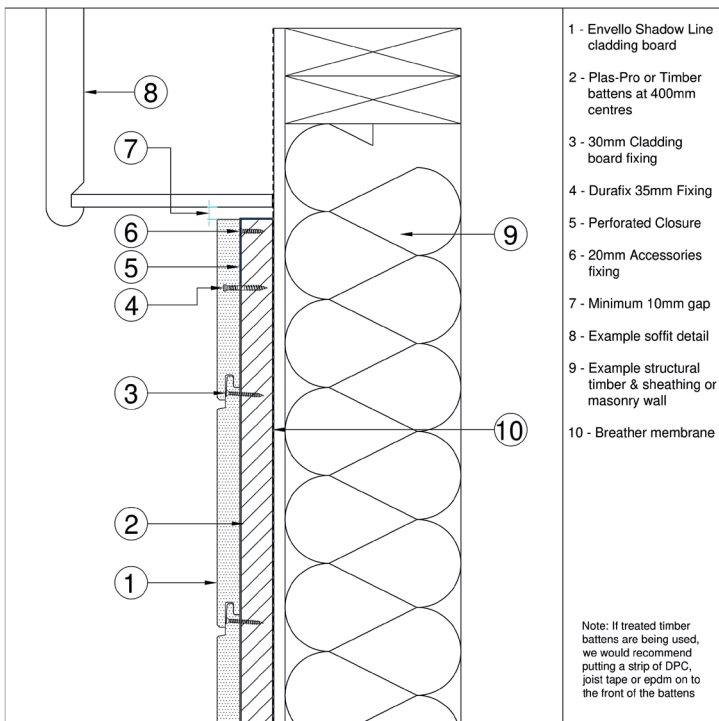

004.

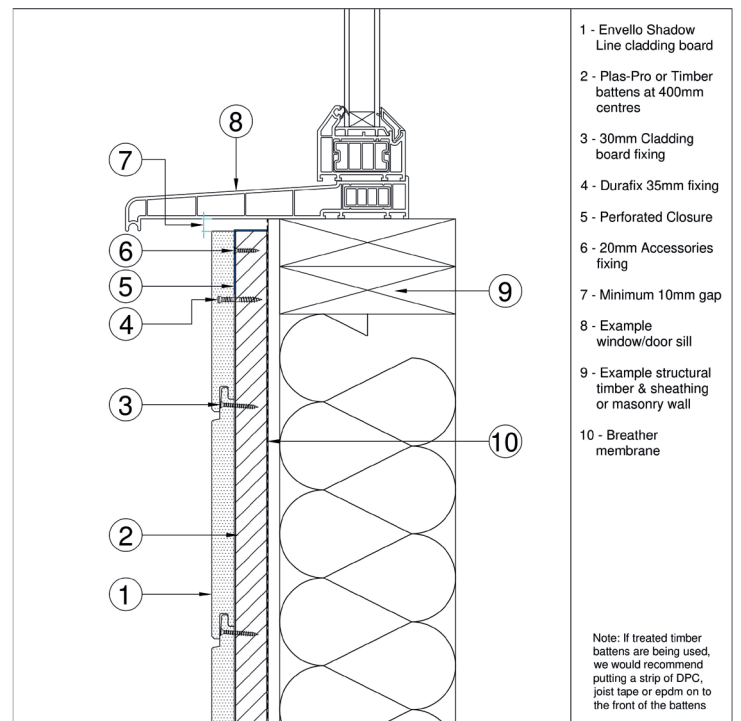

Shadow Line used horizontally

005.

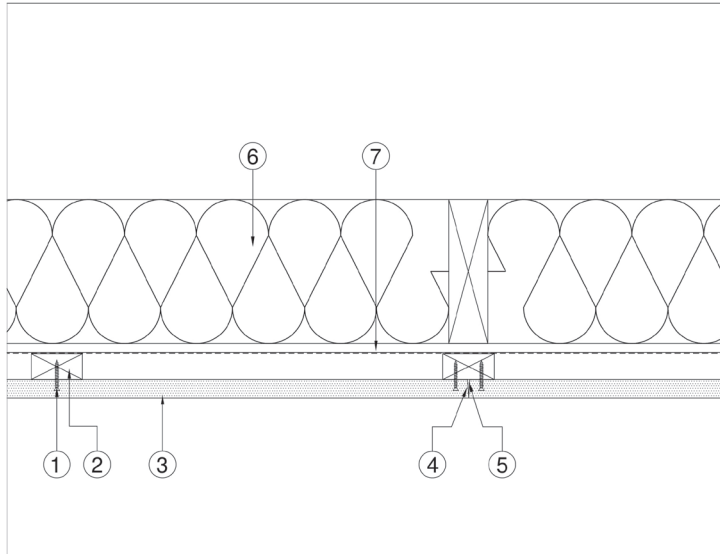

- 1 - 30mm Cladding board fixing
- 2 - Plas-Pro or Timber battens at 400mm centres
- 3 - Envullo Shadow Line cladding board
- 4 - Cladding board squared off with a slight back-cut
- 5 - Gap between back of the boards filled with silicone
- 6 - Example structural timber & sheathing or masonry wall
- 7 - Breather membrane

Note: If treated timber battens are being used, we would recommend putting a strip of DPC, joist tape or epdm on the front of the battens

006.

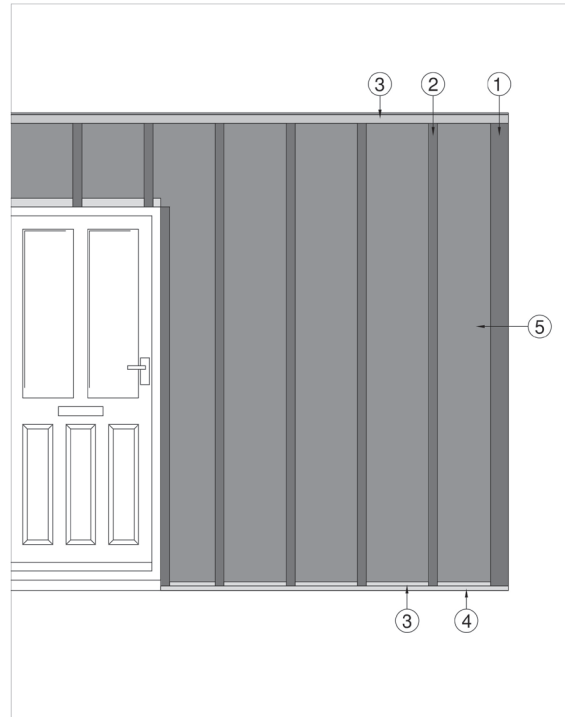

- 1 - 25x100mm Plas-Pro or Timber batten
- 2 - Plas-Pro or Timber battens at 400mm centres
- 3 - Perforated Closure
- 4 - Horizontal Starter Trim
- 5 - Example wall with breather membrane

Note: If treated timber battens are being used, we would recommend putting a strip of DPC, joist tape or epdm on the front of the battens

007.

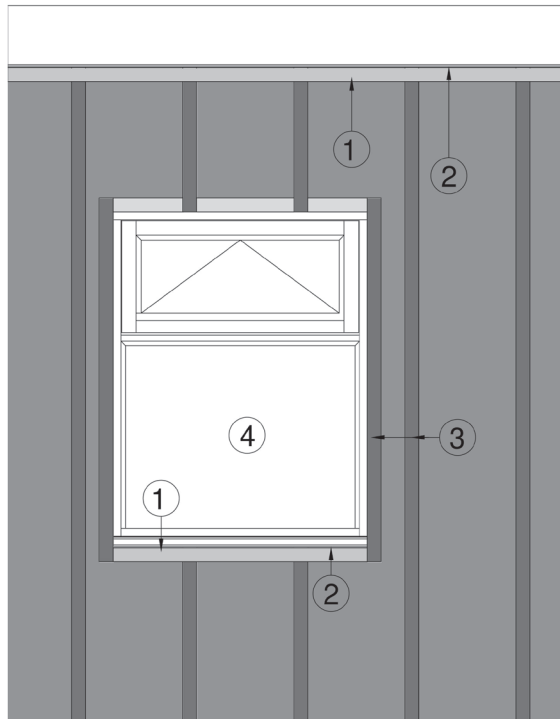

- 1 - Perforated Closure
- 2 - 10mm Gap
- 3 - Plas-Pro or Timber battens at 400mm centres
- 4 - Example window

Note: If treated timber battens are being used, we would recommend putting a strip of DPC, joist tape or epdm on the front of the battens

020.

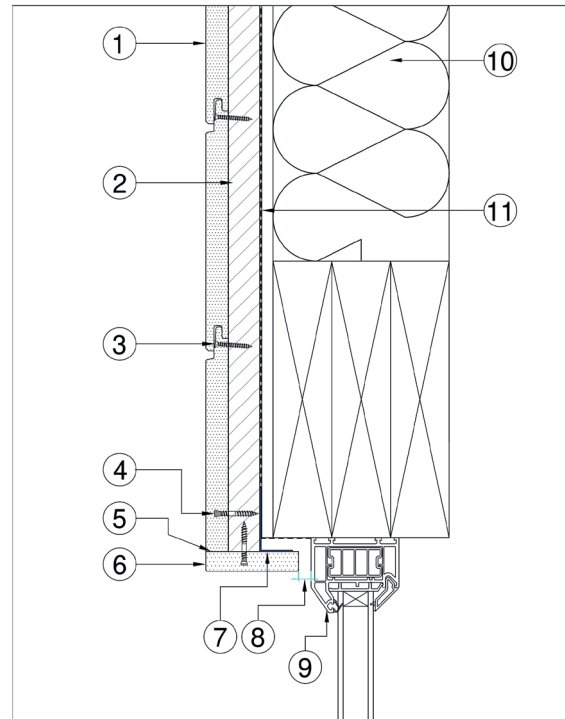

- 1 - Envullo Shadow Line cladding board
- 2 - Plas-Pro or Timber battens at 400mm centres
- 3 - 30mm Cladding board fixing
- 4 - Durafix 35mm fixing
- 5 - Junction between cladding boards and fascia to be sealed with general purpose silicone, the back edge of fascia will need to be finished with touch-up coating if visible
- 6 - Fascia boards, cut down to suit the reveals
- 7 - Perforated Closure
- 8 - Minimum 10mm gap
- 9 - Example window/door detail
- 10 - Example structural timber & sheathing or masonry wall
- 11 - Breather membrane

Note: If treated timber battens are being used, we would recommend putting a strip of DPC, joist tape or epdm on the front of the battens

Shadow Line used horizontally

021.

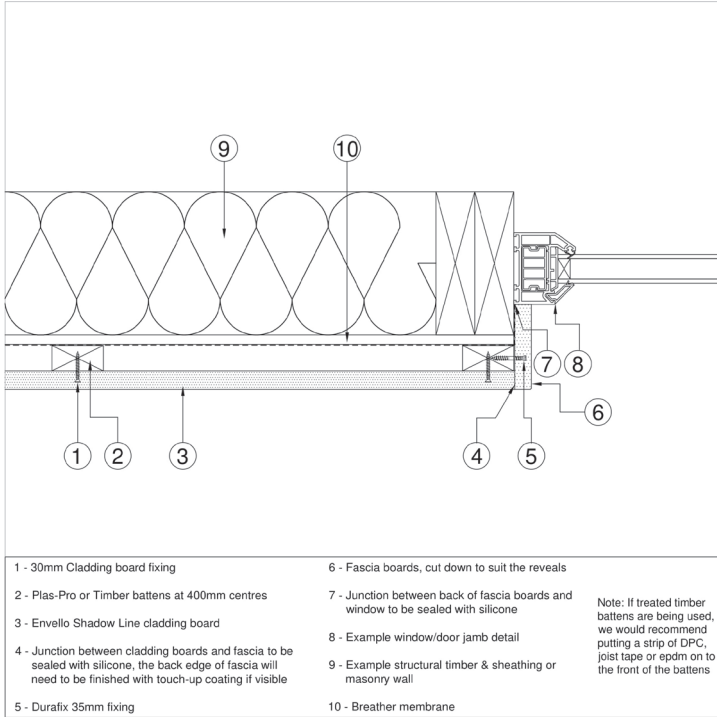

022.

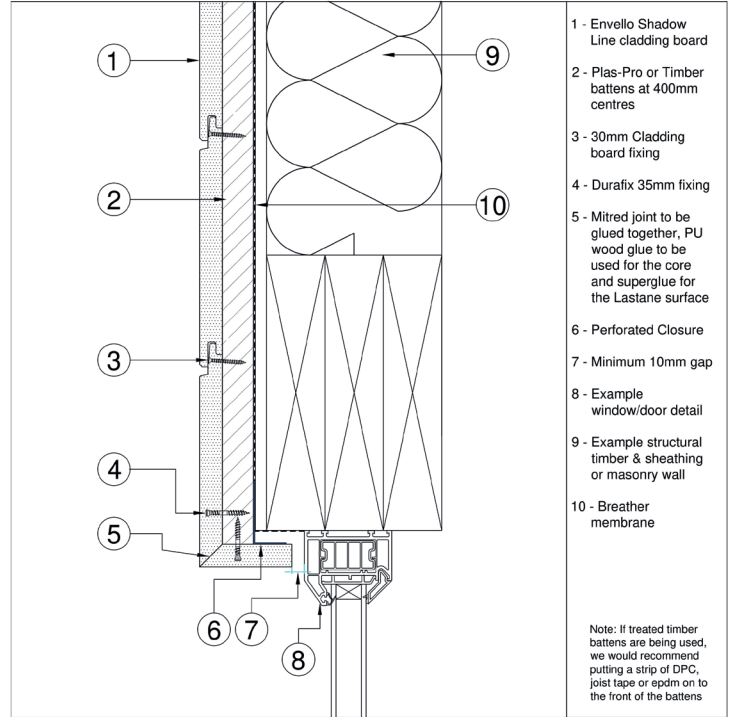

023.

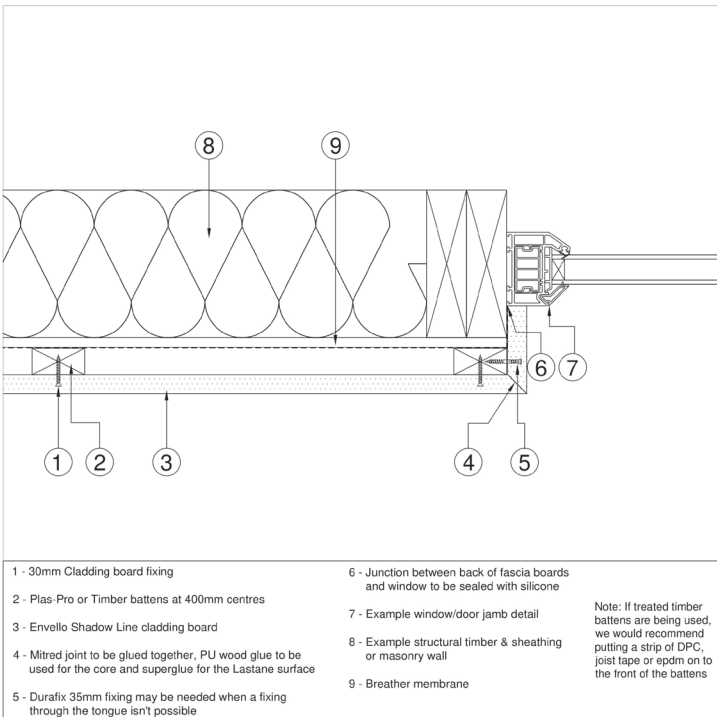

024.

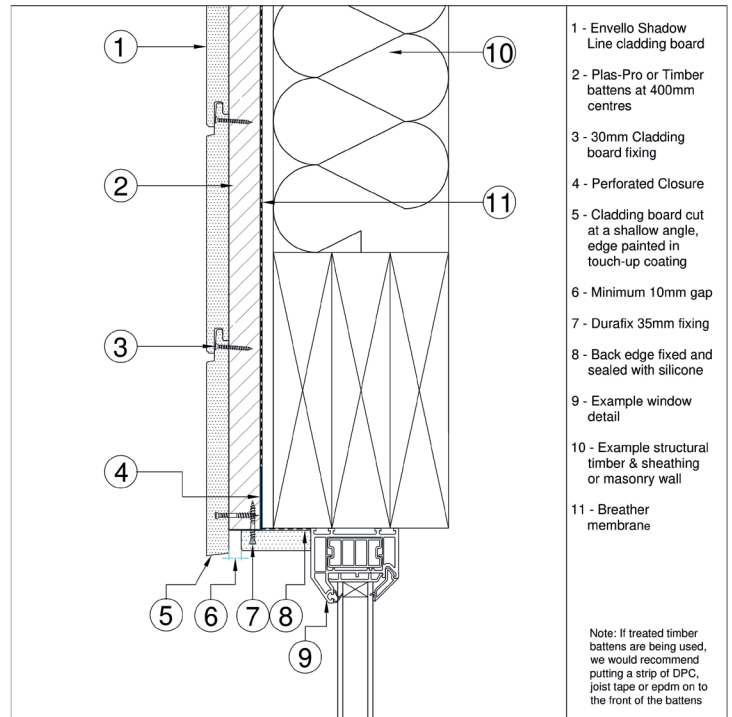

Shadow Line used horizontally

040.

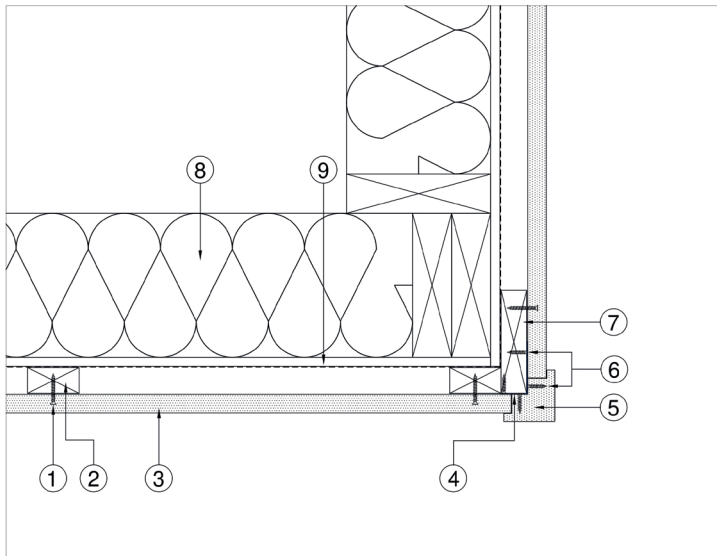

- | | | |
|---|---|---|
| 1 - 30mm Cladding board fixing | 6 - 20mm Accessories screw | <p>Note: If treated timber battens are being used, we would recommend putting a strip of DPC, joint tape or epdm on to the front of the battens</p> |
| 2 - Plas-Pro or Timber battens at 400mm centres | 7 - Plas-Pro or timber batten | |
| 3 - Envello Shadow Line cladding board | 8 - Example structural timber & sheathing or masonry wall | |
| 4 - Perforated closure | 9 - Breather membrane | |
| 5 - External corner profile | | |

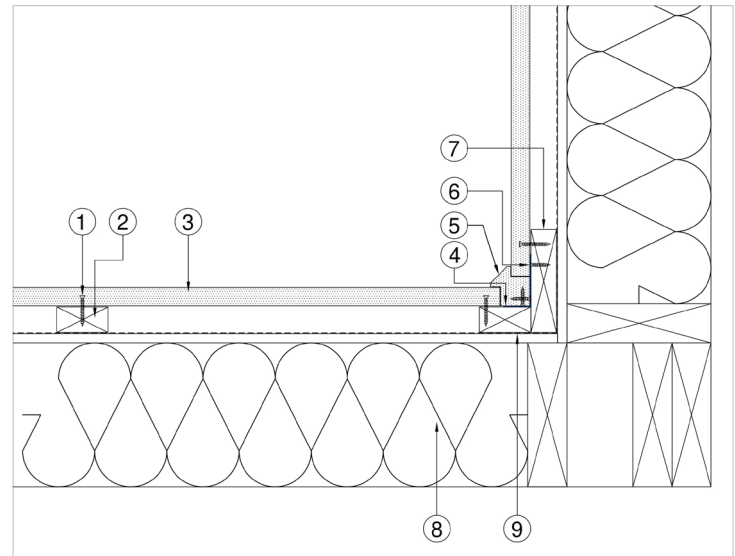

- | | | |
|---|---|---|
| 1 - 30mm Cladding board fixing | 6 - 20mm Accessories screw | <p>Note: If treated timber battens are being used, we would recommend putting a strip of DPC, joint tape or epdm on to the front of the battens</p> |
| 2 - Plas-Pro or Timber battens at 400mm centres | 7 - Plas-Pro or timber batten | |
| 3 - Envello Shadow Line cladding board | 8 - Example structural timber & sheathing or masonry wall | |
| 4 - Perforated closure | 9 - Breather membrane | |
| 5 - Internal corner profile | | |

042.

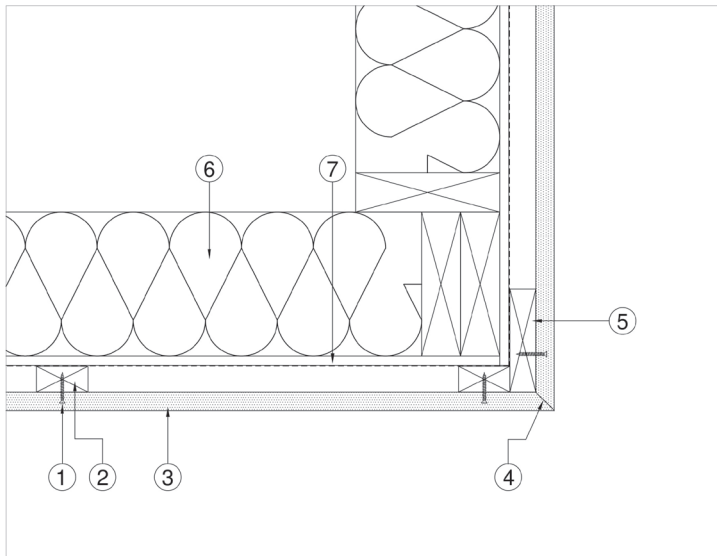

- | | | |
|---|---|---|
| 1 - 30mm Cladding board fixing | 5 - Plas-Pro or timber batten | <p>Note: If treated timber battens are being used, we would recommend putting a strip of DPC, joint tape or epdm on to the front of the battens</p> |
| 2 - Plas-Pro or Timber battens at 400mm centres | 6 - Example structural timber & sheathing or masonry wall | |
| 3 - Envello Shadow Line cladding board | 7 - Breather membrane | |
| 4 - Mitred joint to be glued together, PU wood glue to be used for the core and superglue for the Lastane surface | | |
| | | |

Shadow Line used vertically

101.

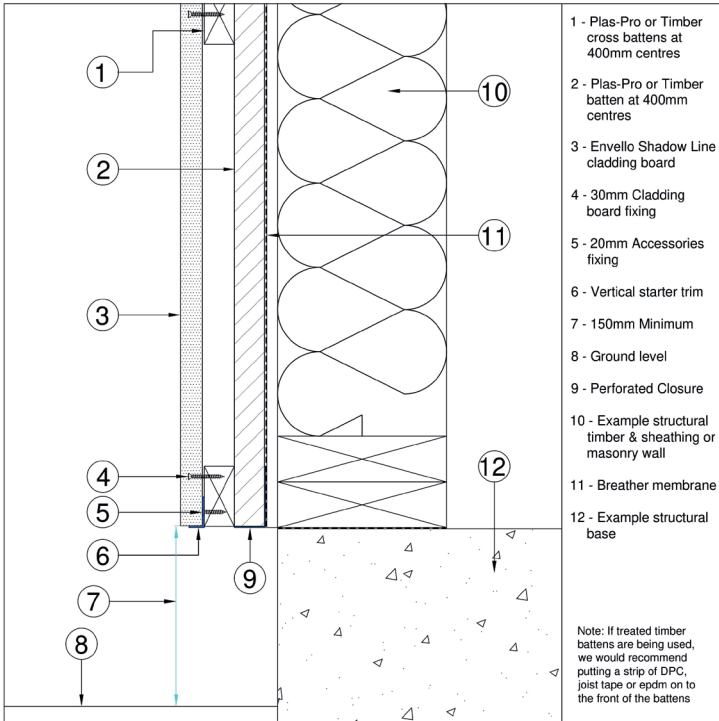

102.

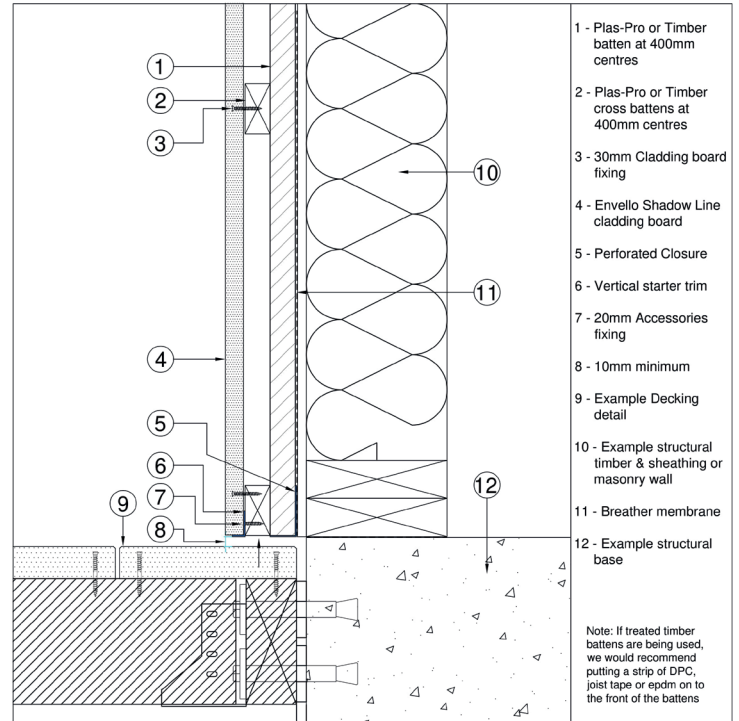

103.

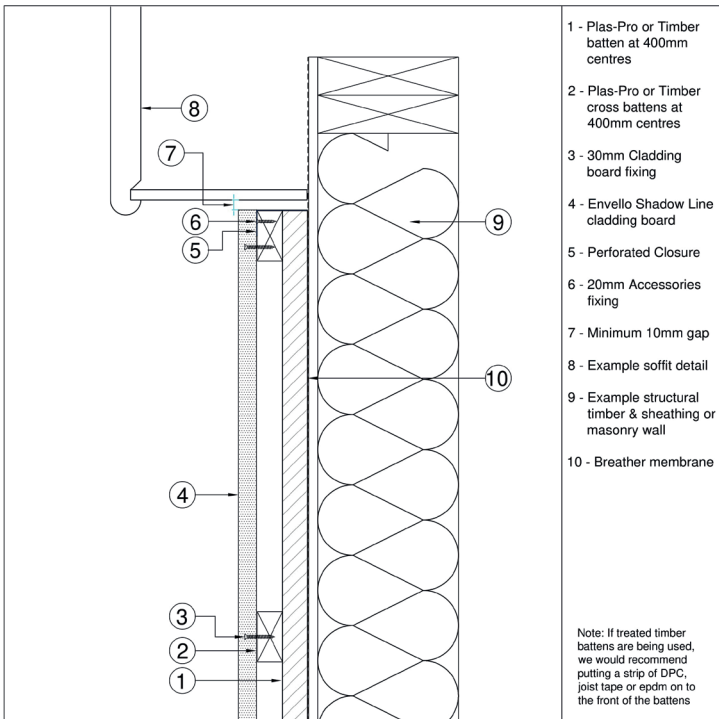

104.

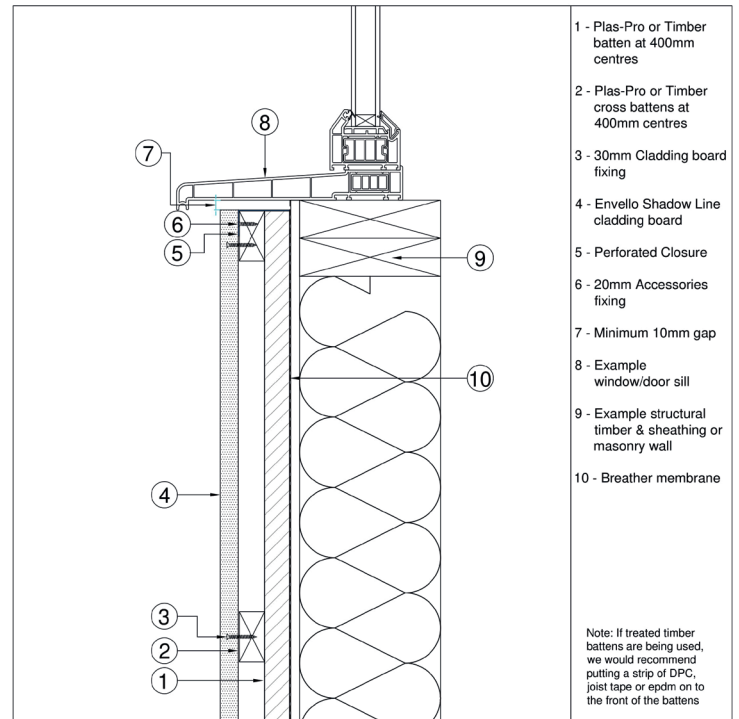

Shadow Line used vertically

105.

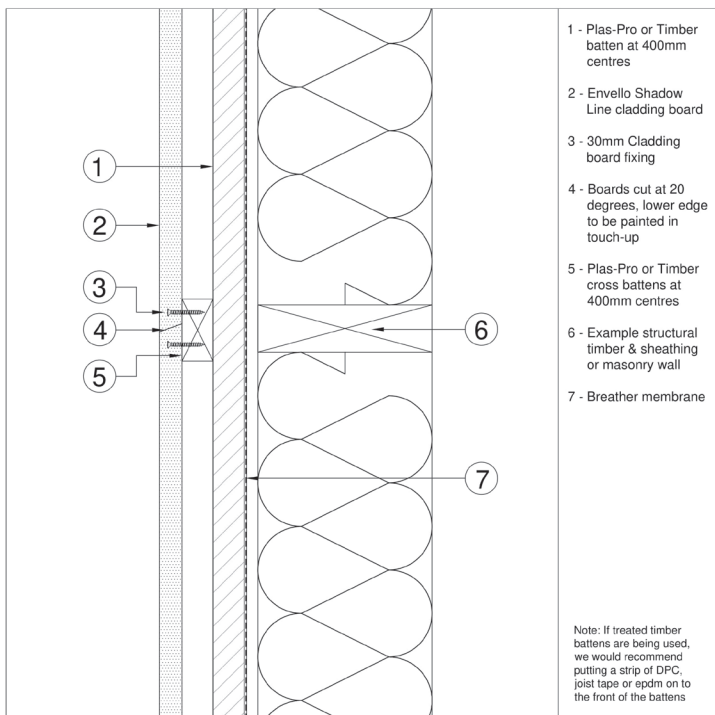

106.

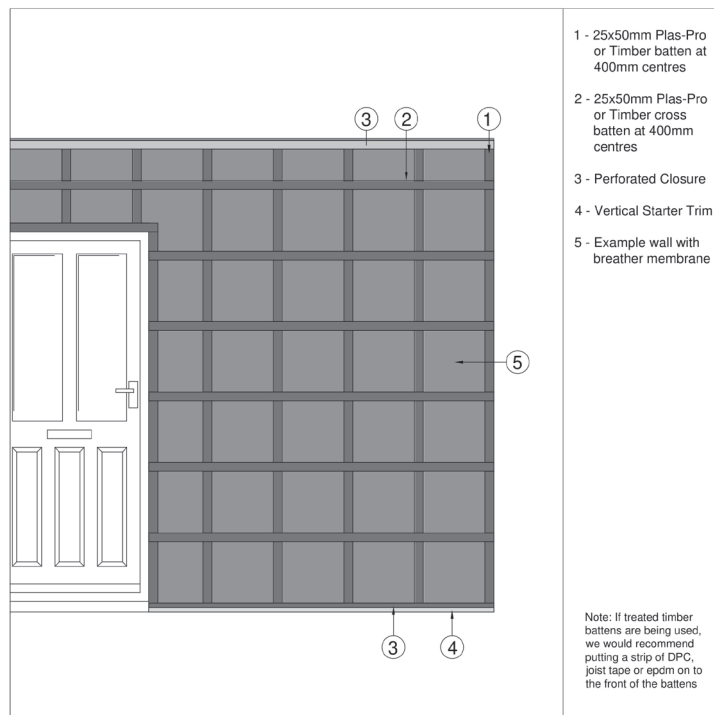

107.

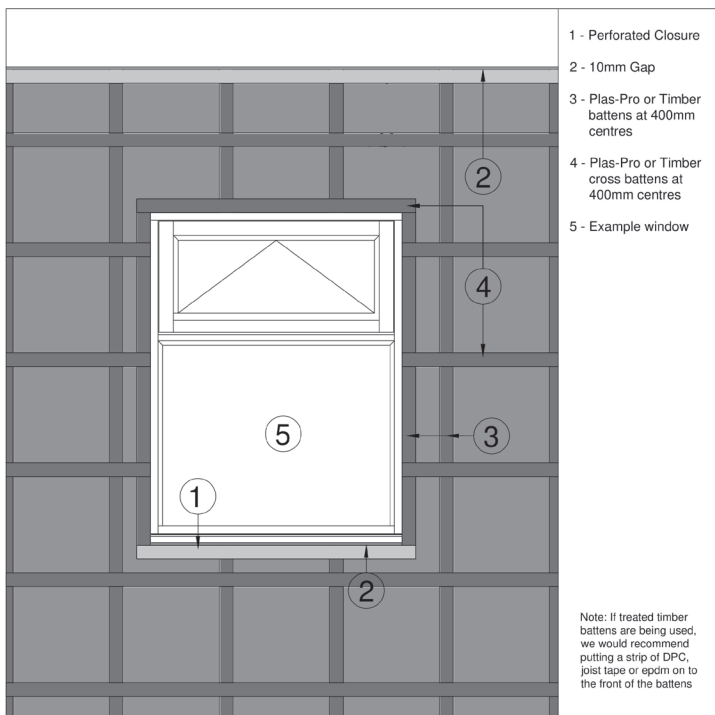

120.

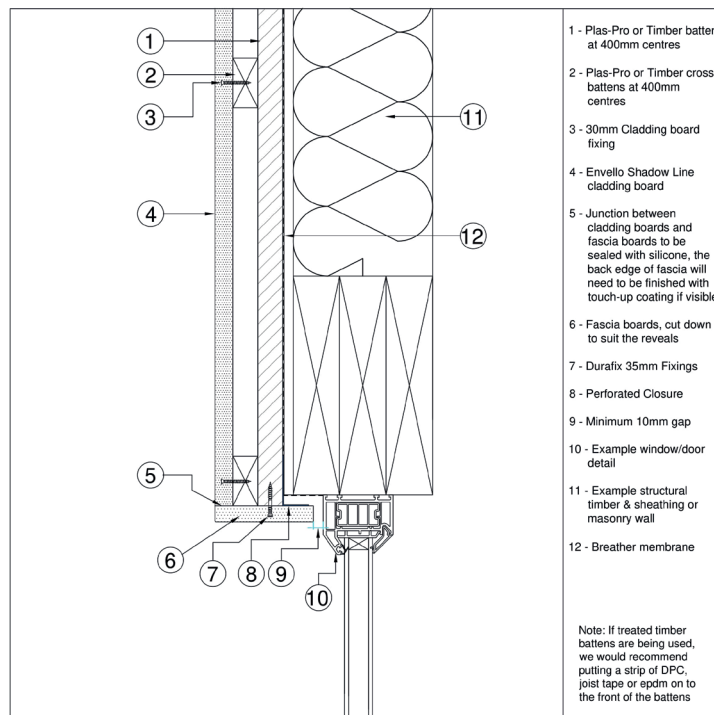

Shadow Line used vertically

121.

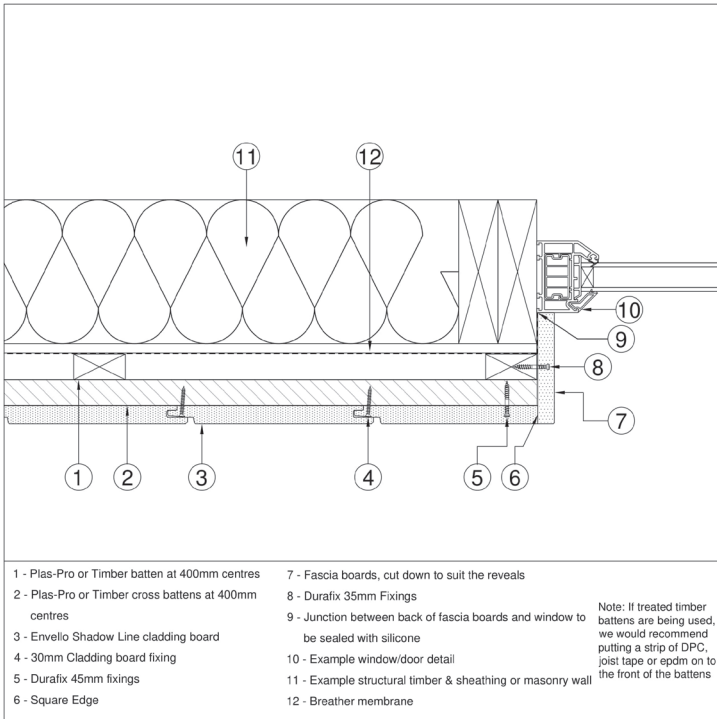

122.

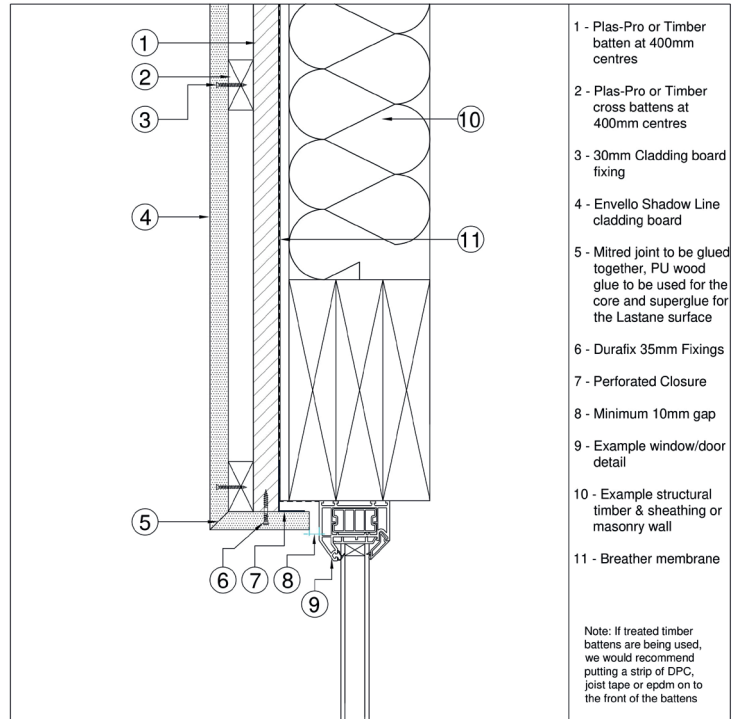

123.

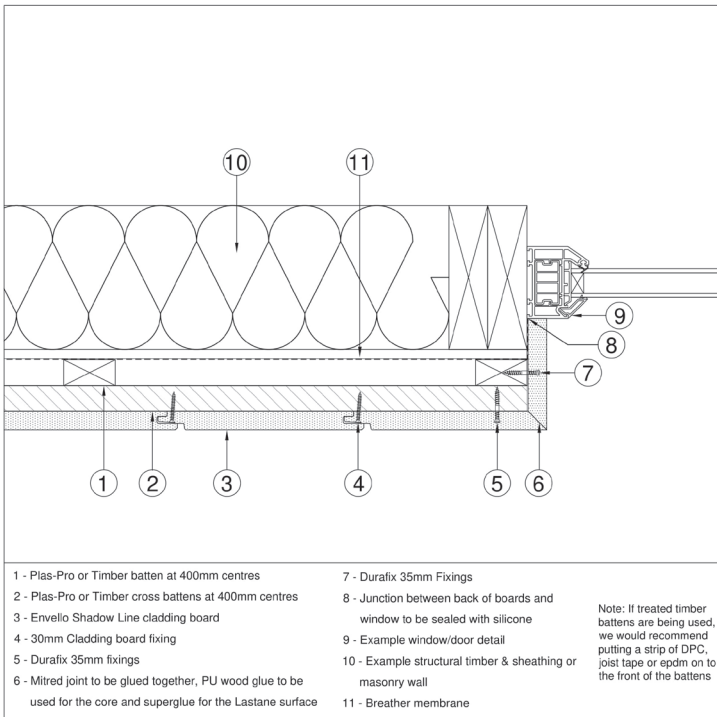

124.

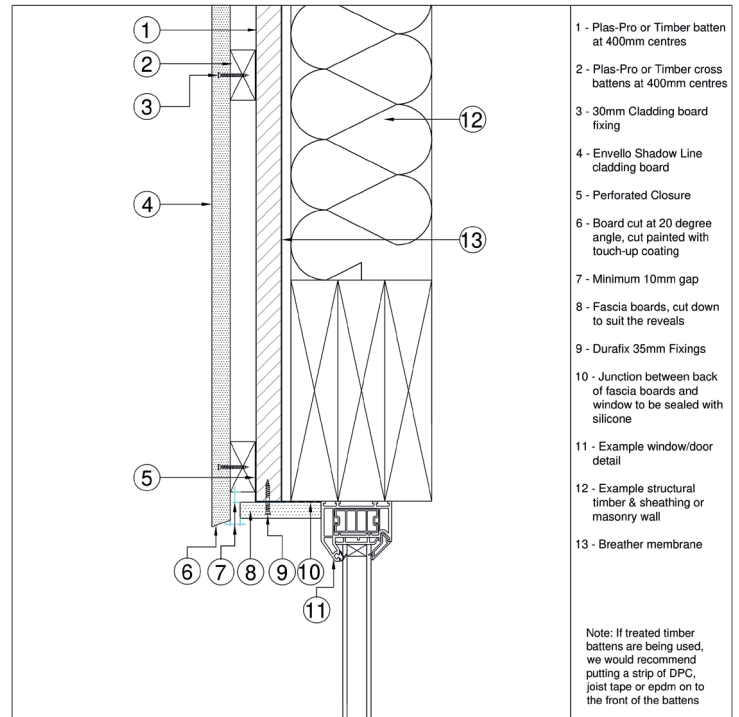

Shadow Line used vertically

140.

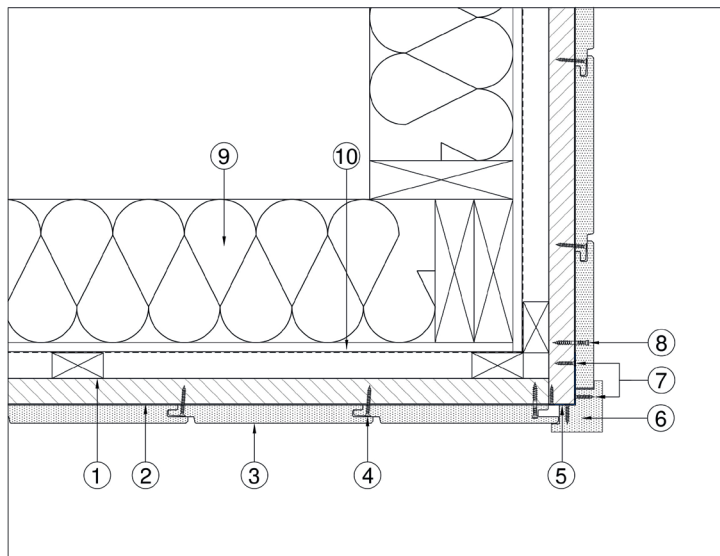

- 1 - Plas-Pro or Timber batten at 400mm centres
- 2 - Plas-Pro or Timber cross battens at 400mm centres
- 3 - Envello Shadow Line cladding board
- 4 - 30mm Cladding board fixing
- 5 - Perforated closure
- 6 - External corner profile
- 7 - 20mm Accessories screw
- 8 - Durafix 35mm fixing
- 9 - Example structural timber & sheathing or masonry wall
- 10 - Breather membrane

Note: If treated timber battens are being used, we would recommend putting a strip of DPC, joint tape or epdm on to the front of the battens

141.

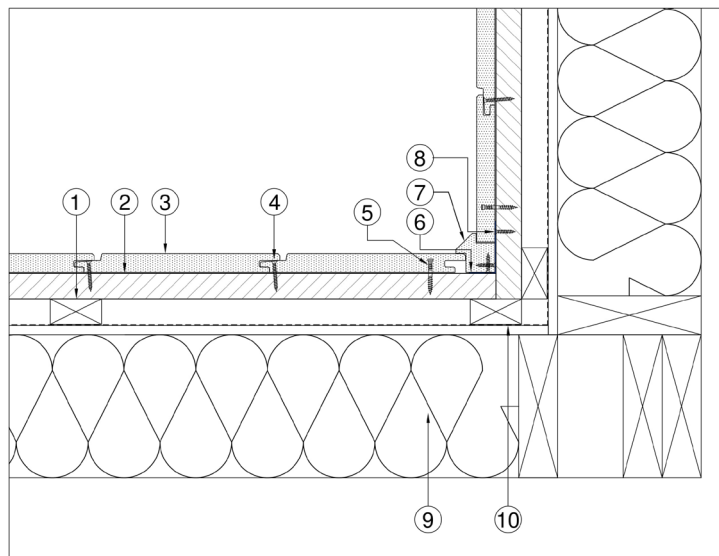

- 1 - Plas-Pro or Timber batten at 400mm centres
- 2 - Plas-Pro or Timber cross battens at 400mm centres
- 3 - Envello Shadow Line cladding board
- 4 - 30mm Cladding board fixing
- 5 - Durafix 35mm fixing
- 6 - Perforated closure
- 7 - Internal corner profile
- 8 - 20mm Accessories screw
- 9 - Example structural timber & sheathing or masonry wall
- 10 - Breather membrane

Note: If treated timber battens are being used, we would recommend putting a strip of DPC, joint tape or epdm on to the front of the battens

142.

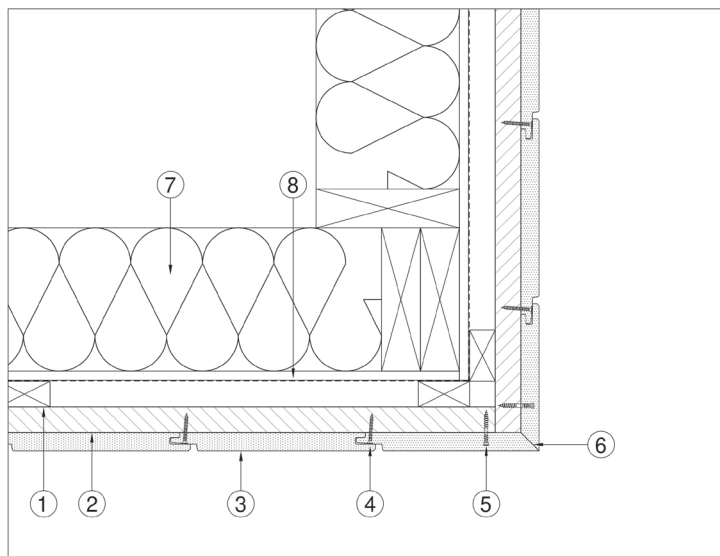

- 1 - Plas-Pro or Timber batten at 400mm centres
- 2 - Plas-Pro or Timber cross battens at 400mm centres
- 3 - Envello Shadow Line cladding board
- 4 - 30mm Cladding board fixing
- 5 - Durafix 35mm fixings
- 6 - Mitred joint to be glued together, PU wood glue to be used for the core and superglue for the Lastane surface
- 7 - Example structural timber & sheathing or masonry wall
- 8 - Breather membrane

Note: If treated timber battens are being used, we would recommend putting a strip of DPC, joint tape or epdm on to the front of the battens

Board & Batten used vertically

201.

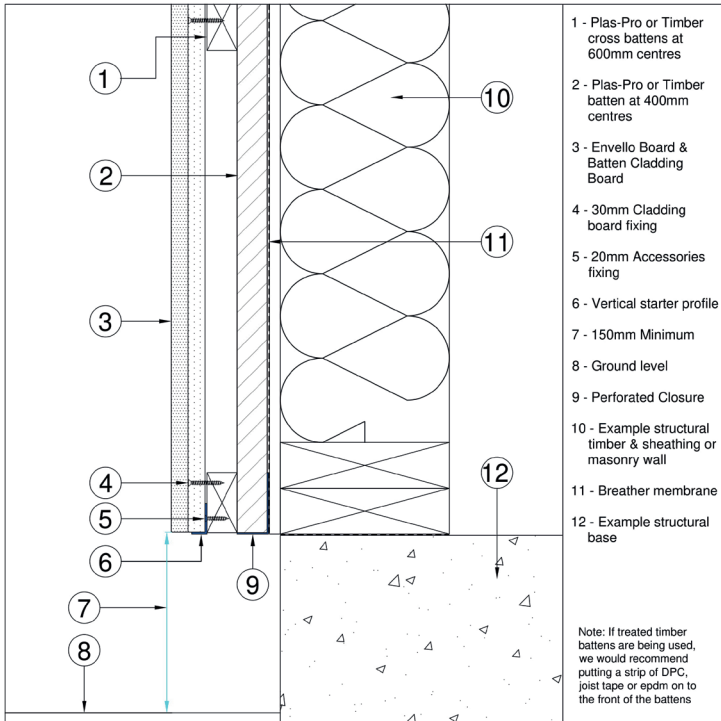

202.

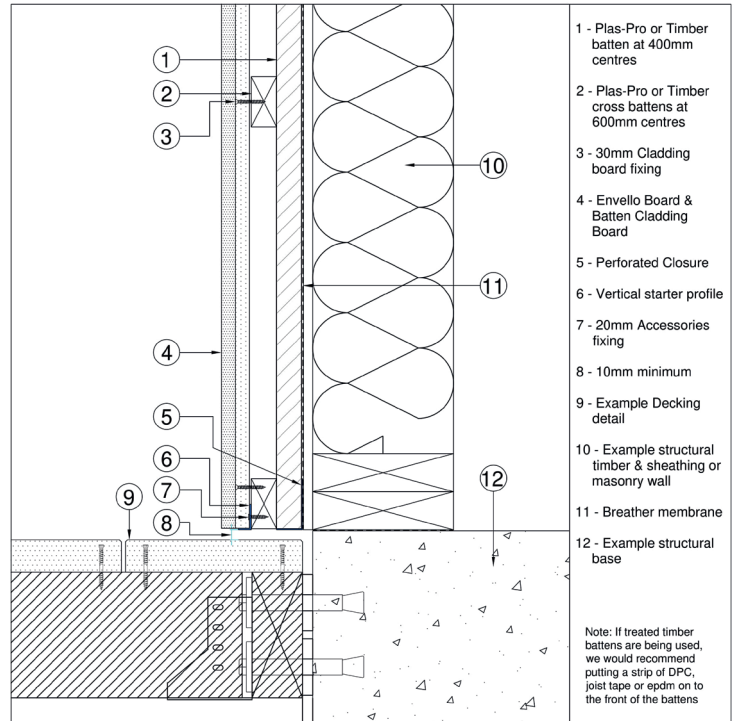

203.

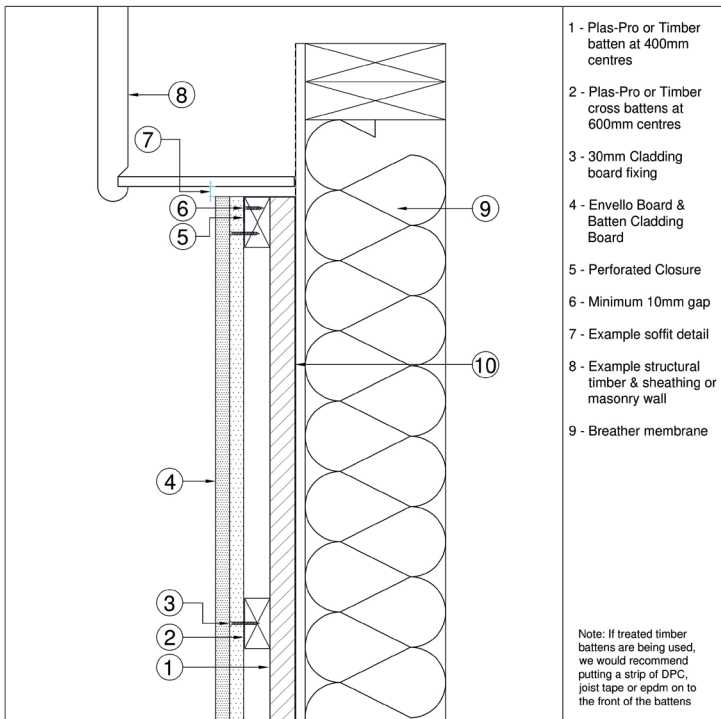

204.

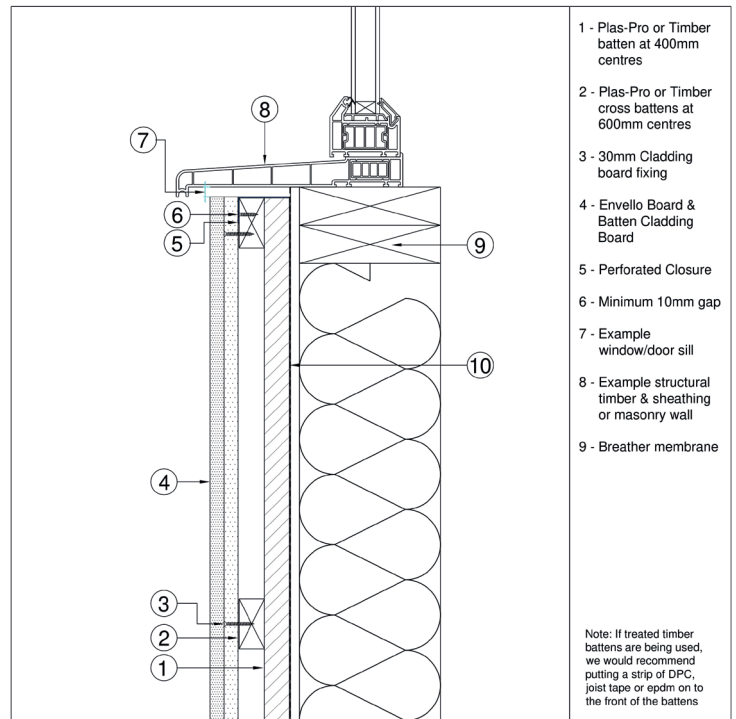

Board & Batten used vertically

205.

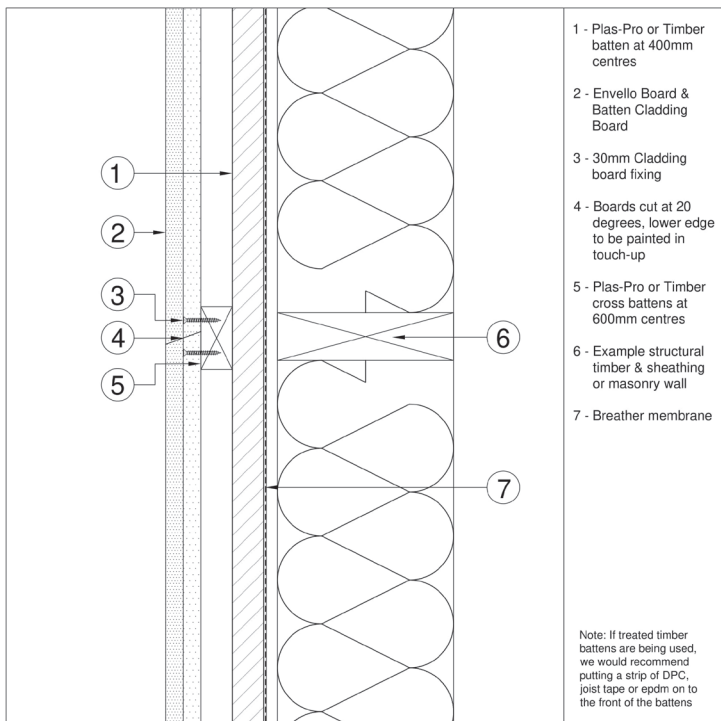

206.

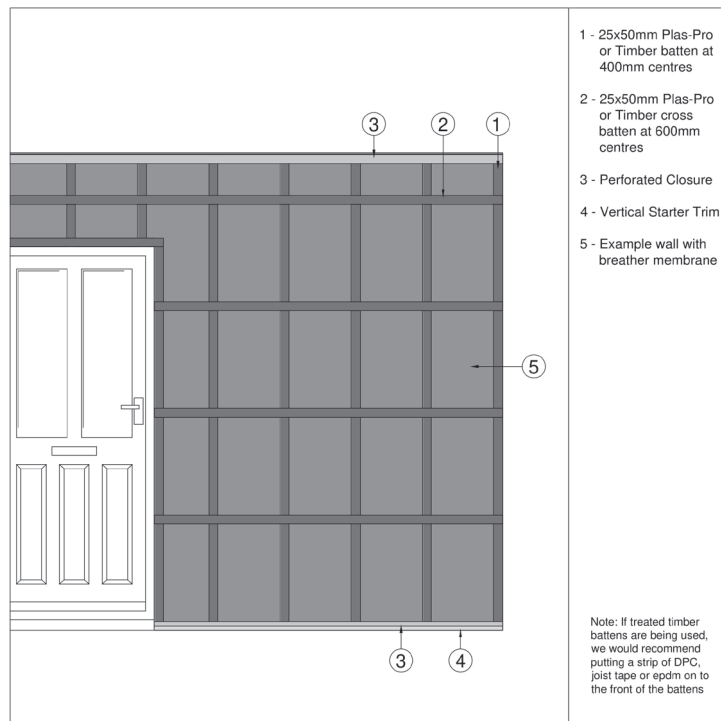

207.

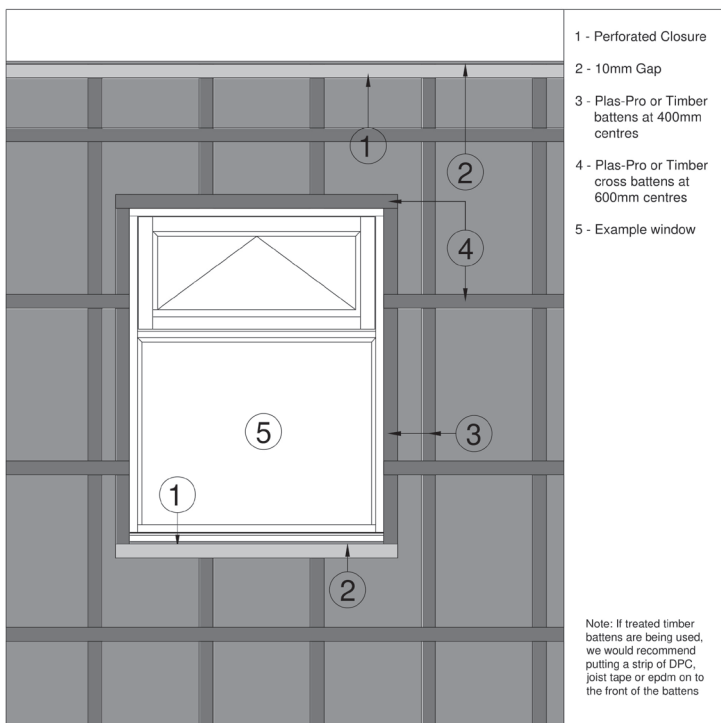

220.

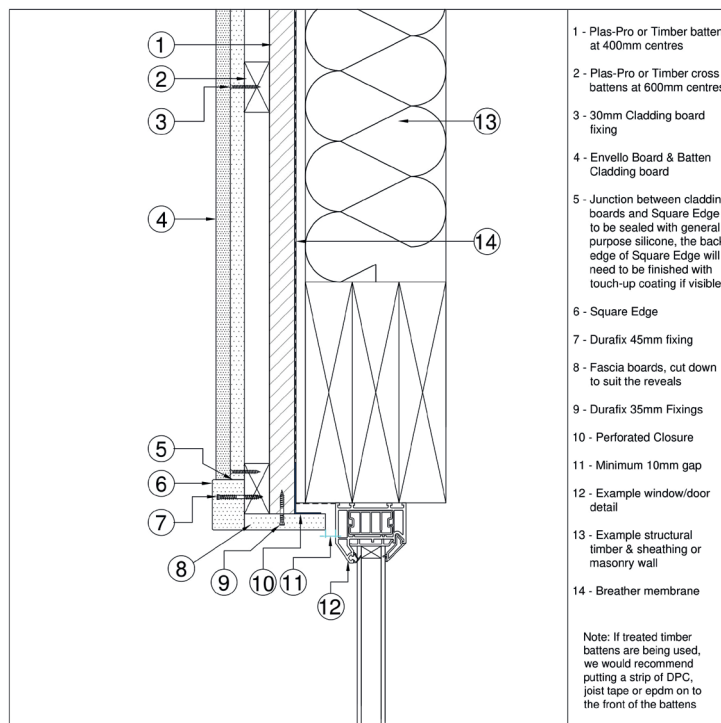

Board & Batten used vertically

221.

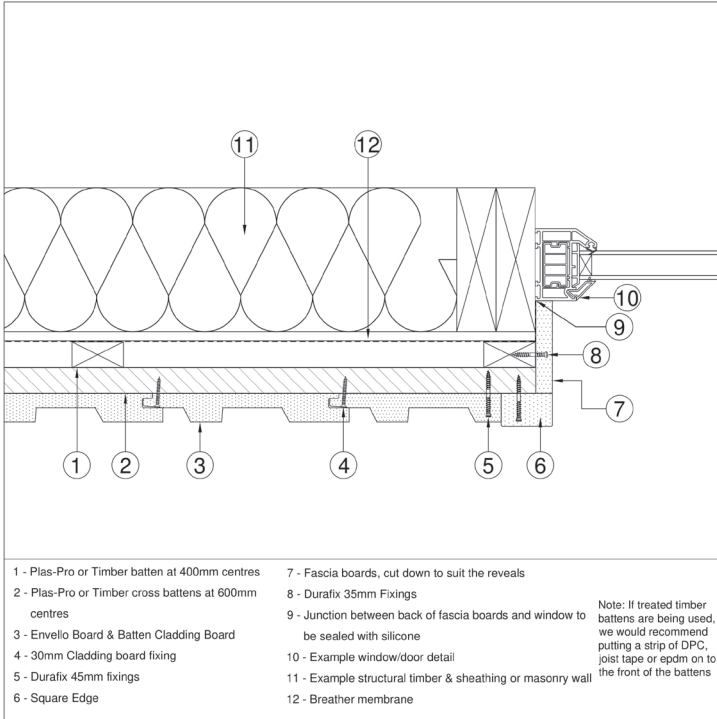

222.

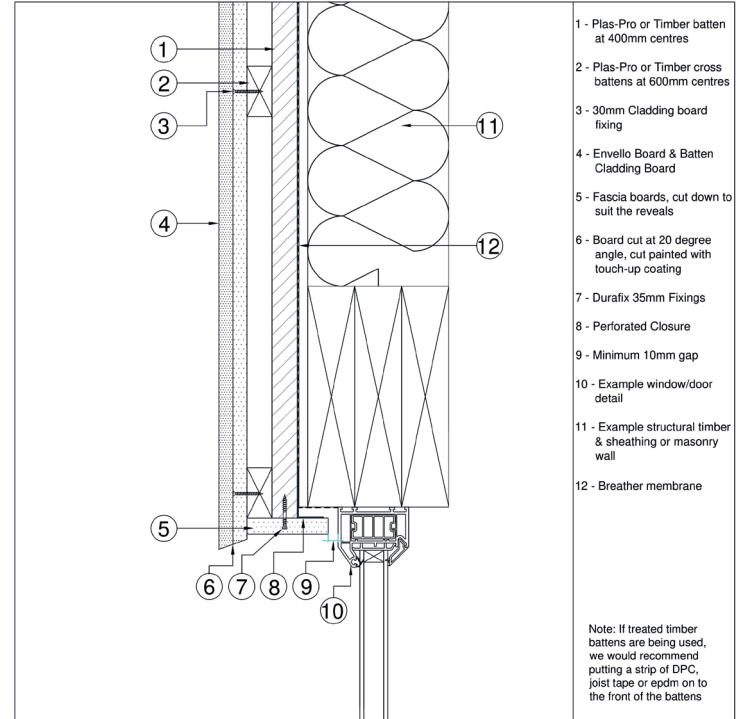

223.

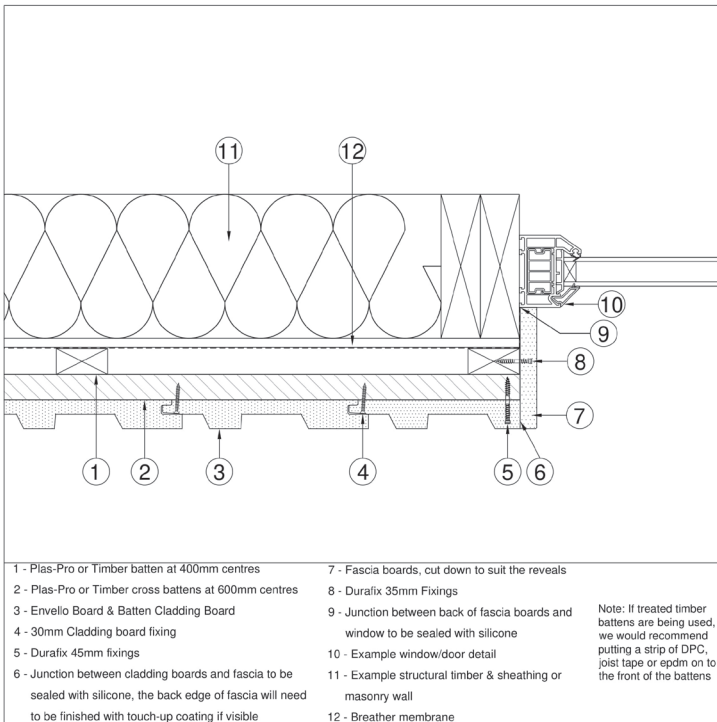

224.

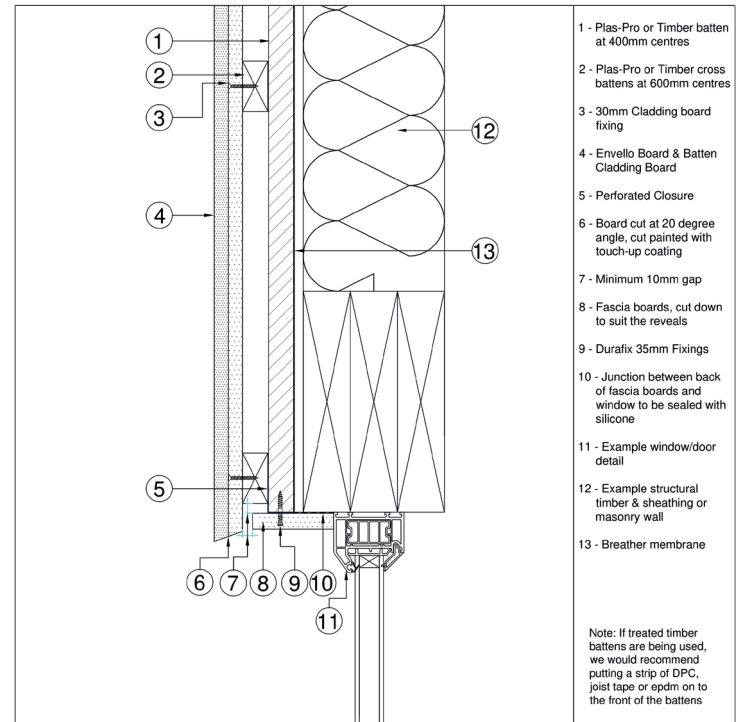

Board & Batten used vertically

240.

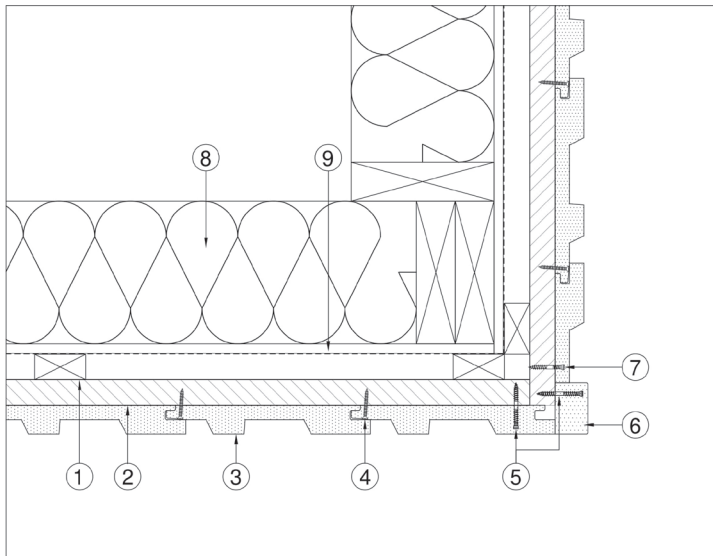

- | | | |
|---|---|--|
| 1 - Plas-Pro or Timber batten at 400mm centres | 6 - Square Edge, back edge of Square Edge will need to be finished with touch-up coating if visible | Note: If treated timber battens are being used, we would recommend putting a strip of DPC, joist tape or epdm on to the front of the battens |
| 2 - Plas-Pro or Timber cross battens at 600mm centres | 7 - Durafix 35mm fixing | |
| 3 - Envello Board & Batten Cladding Board | 8 - Example structural timber & sheathing or masonry wall | |
| 4 - 30mm Cladding board fixing | 9 - Breather membrane | |
| 5 - Durafix 45mm fixings | | |

241.

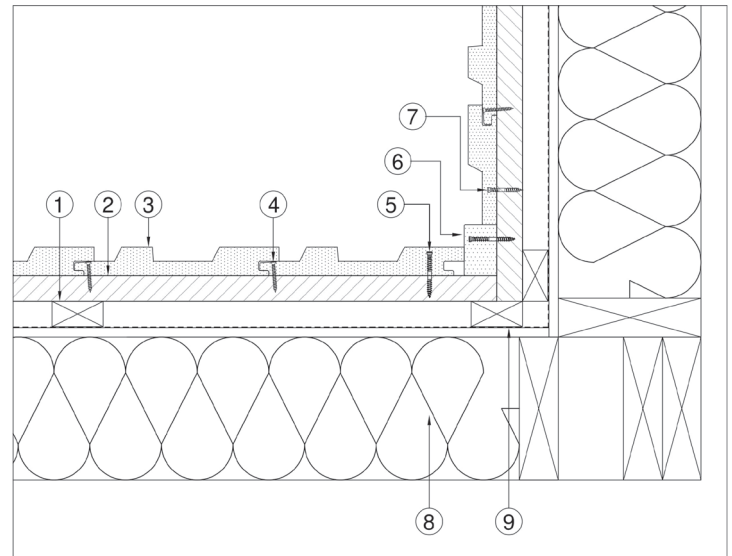

- | | | |
|---|---|--|
| 1 - Plas-Pro or Timber batten at 400mm centres | 6 - Square edging | Note: If treated timber battens are being used, we would recommend putting a strip of DPC, joist tape or epdm on to the front of the battens |
| 2 - Plas-Pro or Timber cross battens at 600mm centres | 7 - Durafix 35mm fixing | |
| 3 - Envello Board & Batten Cladding Board | 8 - Example structural timber & sheathing or masonry wall | |
| 4 - 30mm Cladding board fixing | 9 - Breather membrane | |
| 5 - Durafix 45mm fixings | | |

242.

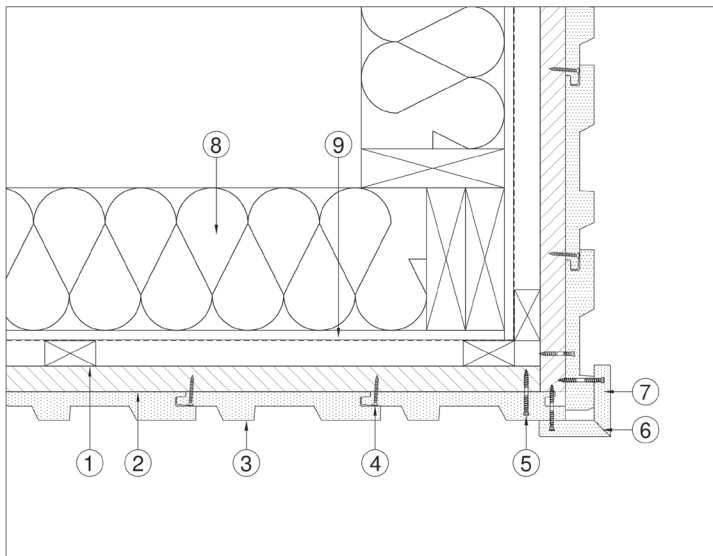

- | | | |
|---|---|--|
| 1 - Plas-Pro or Timber batten at 400mm centres | 6 - Mitred joint to be glued together, PU wood glue to be used for the core and superglue for the Lastane surface | Note: If treated timber battens are being used, we would recommend putting a strip of DPC, joist tape or epdm on to the front of the battens |
| 2 - Plas-Pro or Timber cross battens at 600mm centres | 7 - Fascia Board mitred | |
| 3 - Envello Board & Batten Cladding Board | 8 - Example structural timber & sheathing or masonry wall | |
| 4 - 30mm Cladding board fixing | 9 - Breather membrane | |
| 5 - Durafix 45mm fixings | | |

243.

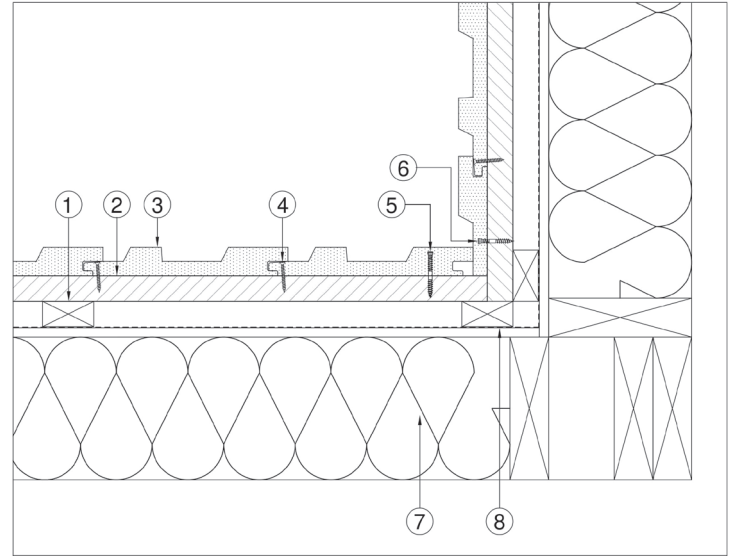

- | | | |
|---|---|--|
| 1 - Plas-Pro or Timber batten at 400mm centres | 6 - Durafix 35mm fixing | Note: If treated timber battens are being used, we would recommend putting a strip of DPC, joist tape or epdm on to the front of the battens |
| 2 - Plas-Pro or Timber cross battens at 600mm centres | 7 - Example structural timber & sheathing or masonry wall | |
| 3 - Envello Board & Batten Cladding Board | 8 - Breather membrane | |
| 4 - 30mm Cladding board fixing | | |
| 5 - Durafix 45mm fixings | | |

Board & Batten used horizontally

301.

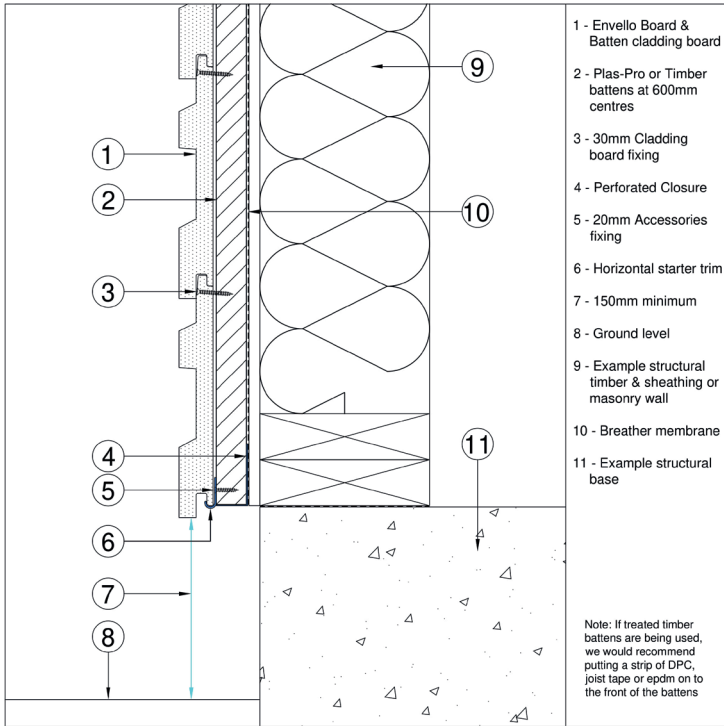

302.

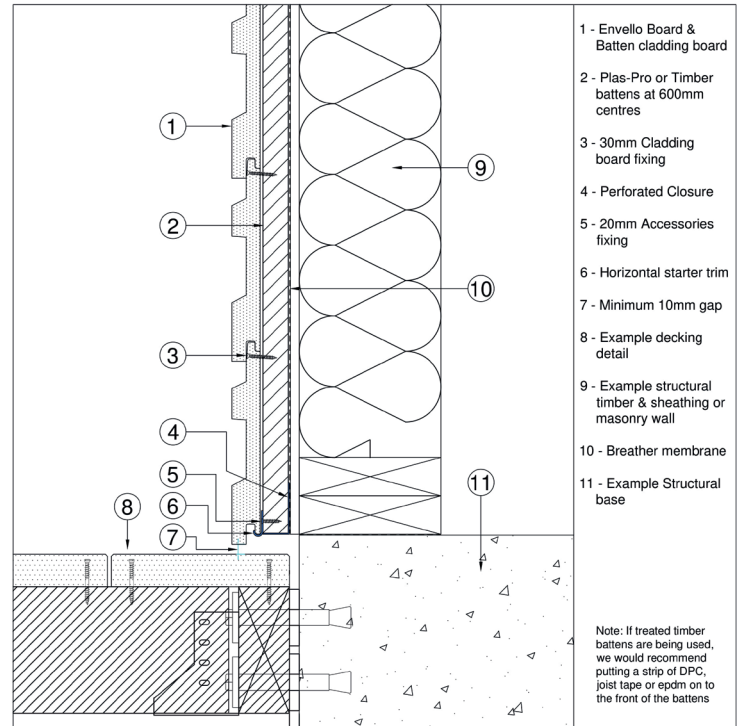

303.

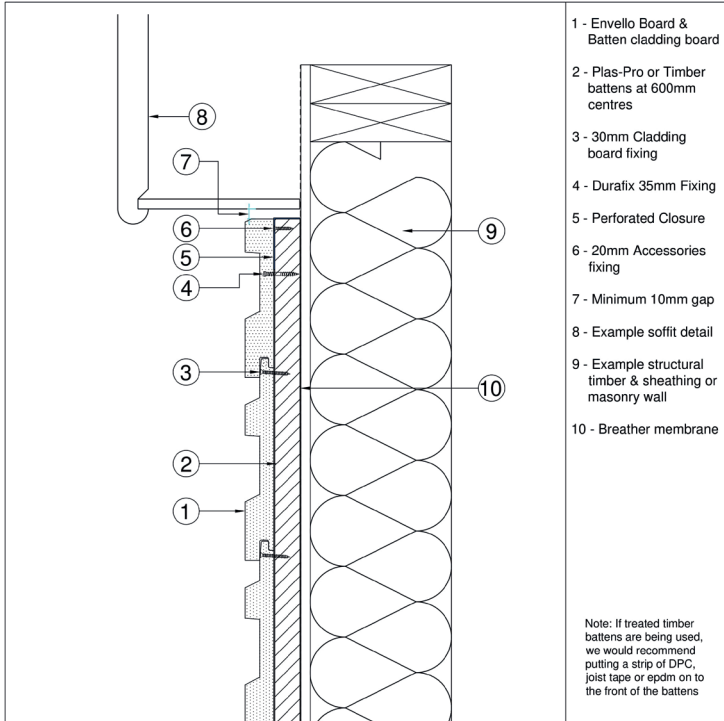

304.

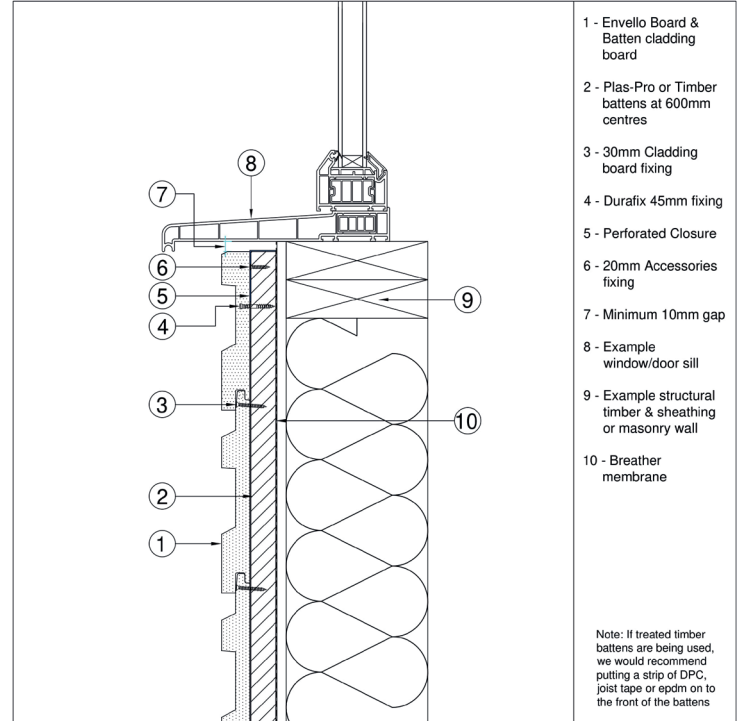

Board & Batten used horizontally

305.

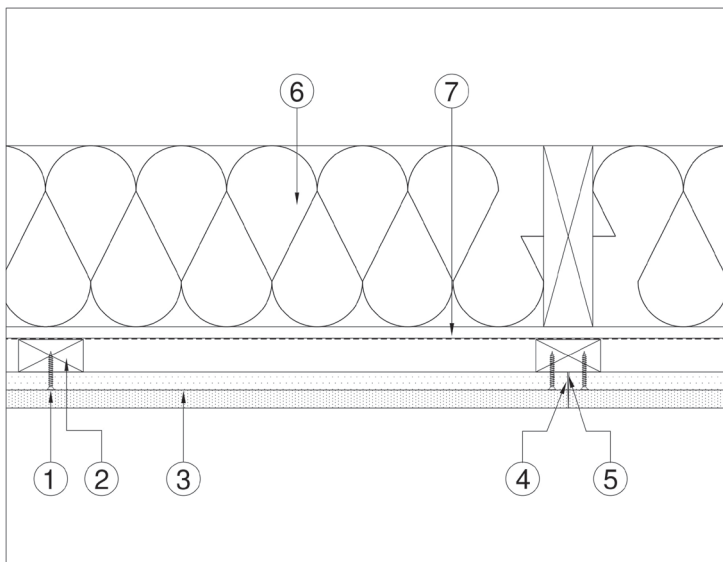

- 1 - 30mm Cladding board fixing
- 2 - Plas-Pro or Timber battens at 600mm centres
- 3 - Envello Board & Batten cladding board
- 4 - Cladding board squared off with a very slight back-cut

- 5 - Gap between back of the boards filled with silicone
- 6 - Example structural timber & sheathing or masonry wall
- 7 - Breather membrane

Note: If treated timber battens are being used, we would recommend putting a strip of DPC, joist tape or epdm on to the front of the battens

306.

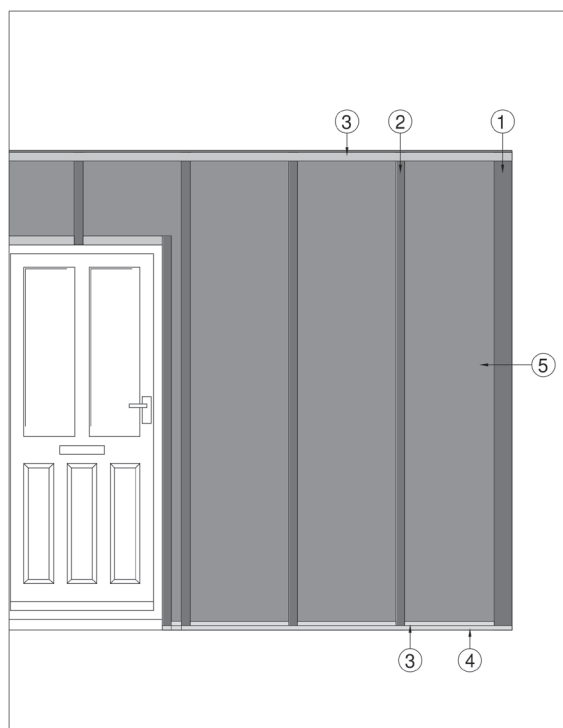

- 1 - 25x100mm Plas-Pro or Timber batten
- 2 - Plas-Pro or Timber battens at 600mm centres
- 3 - Perforated Closure
- 4 - Horizontal Starter Trim
- 5 - Example wall with breather membrane

Note: If treated timber battens are being used, we would recommend putting a strip of DPC, joist tape or epdm on to the front of the battens

307.

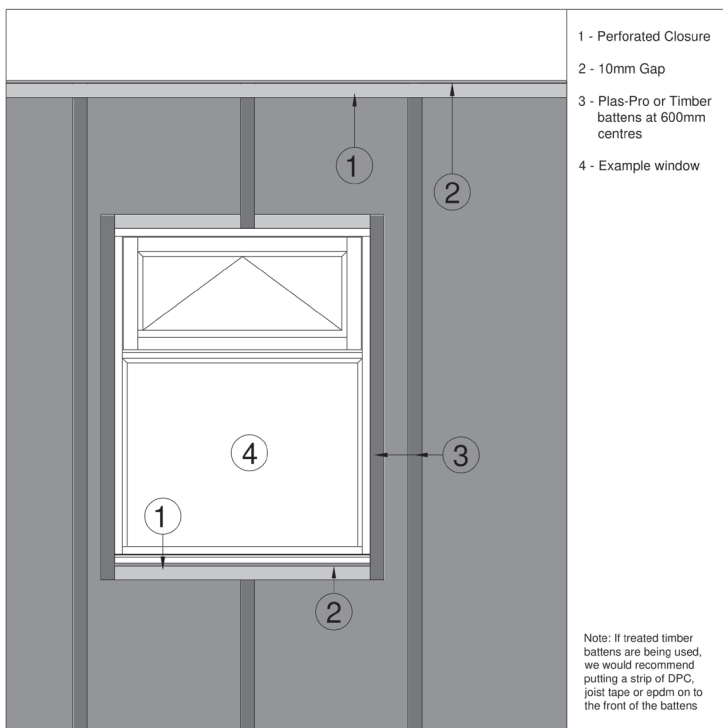

- 1 - Perforated Closure
- 2 - 10mm Gap
- 3 - Plas-Pro or Timber battens at 600mm centres
- 4 - Example window

Note: If treated timber battens are being used, we would recommend putting a strip of DPC, joist tape or epdm on to the front of the battens

320.

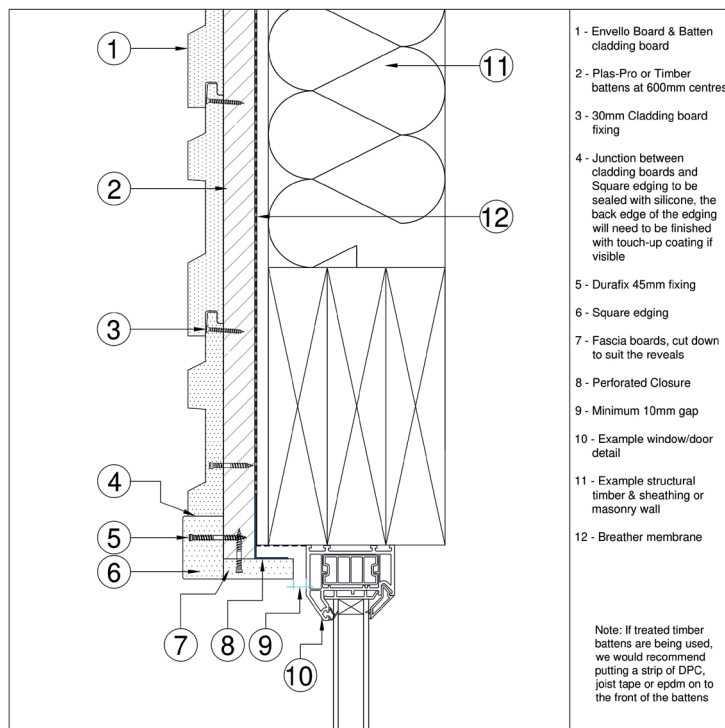

- 1 - Envello Board & Batten cladding board
- 2 - Plas-Pro or Timber battens at 600mm centres
- 3 - 30mm Cladding board fixing
- 4 - Junction between cladding boards and Square edging to be sealed with silicone, the back edge of the edging will need to be finished with touch-up coating if visible
- 5 - Durafix 45mm fixing
- 6 - Square edging
- 7 - Fascia boards, cut down to suit the reveals
- 8 - Perforated Closure
- 9 - Minimum 10mm gap
- 10 - Example window/door detail
- 11 - Example structural timber & sheathing or masonry wall
- 12 - Breather membrane

Note: If treated timber battens are being used, we would recommend putting a strip of DPC, joist tape or epdm on to the front of the battens

Board & Batten used horizontally

321.

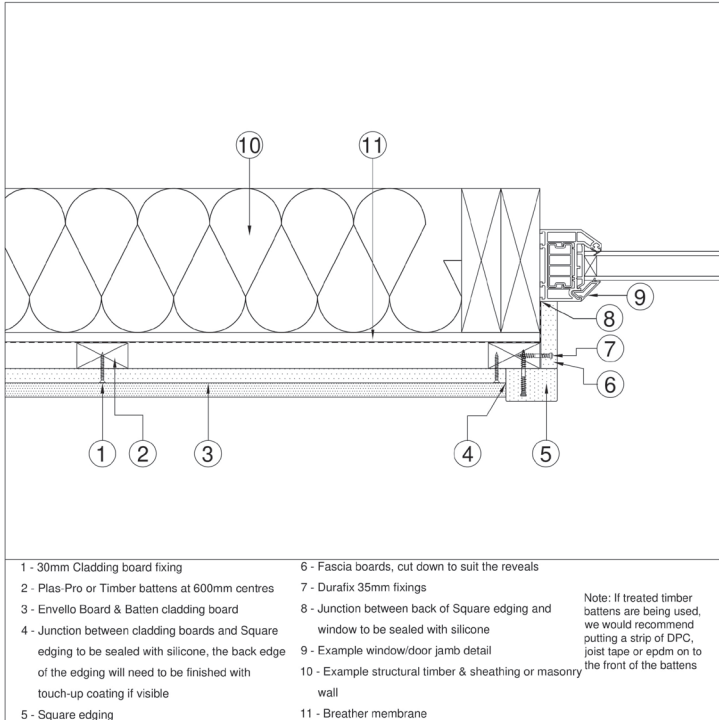

322.

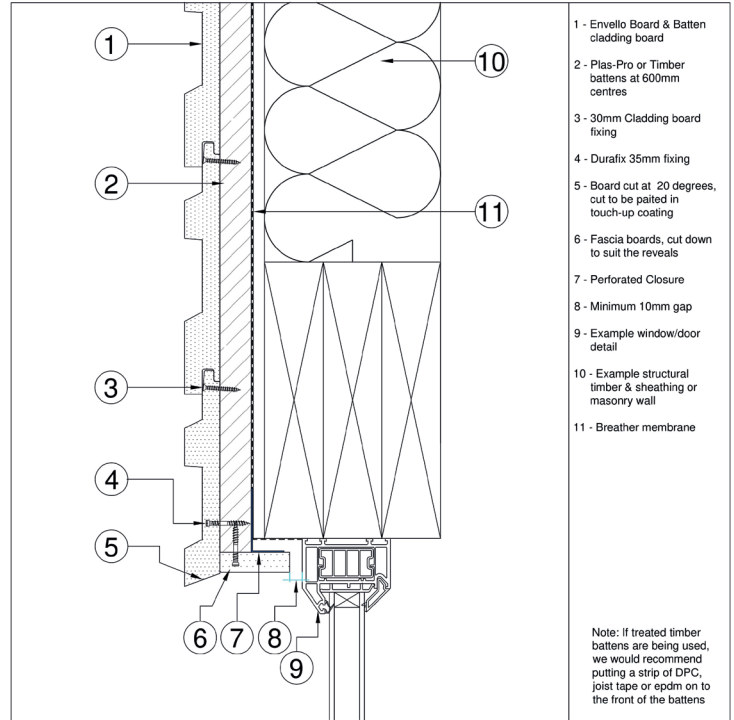

323.

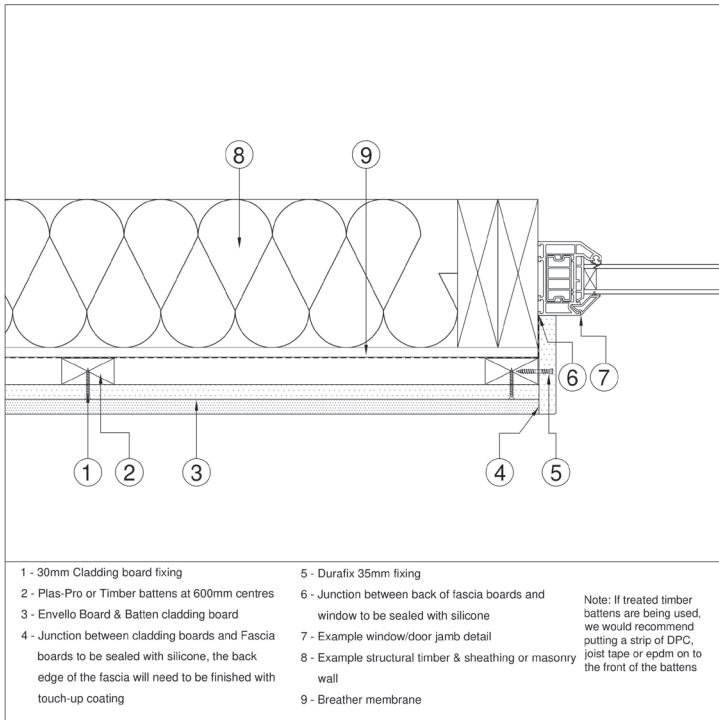

340.

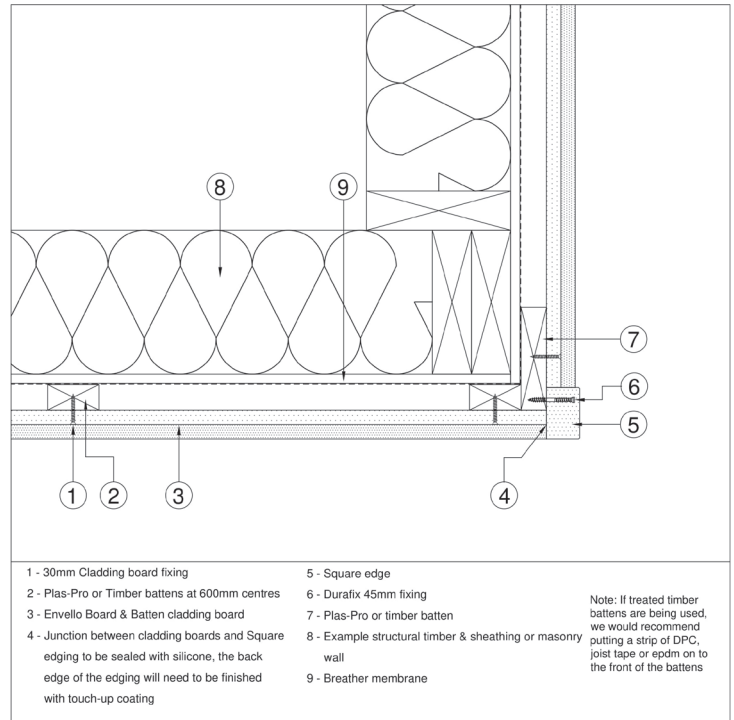

Board & Batten used horizontally

341.

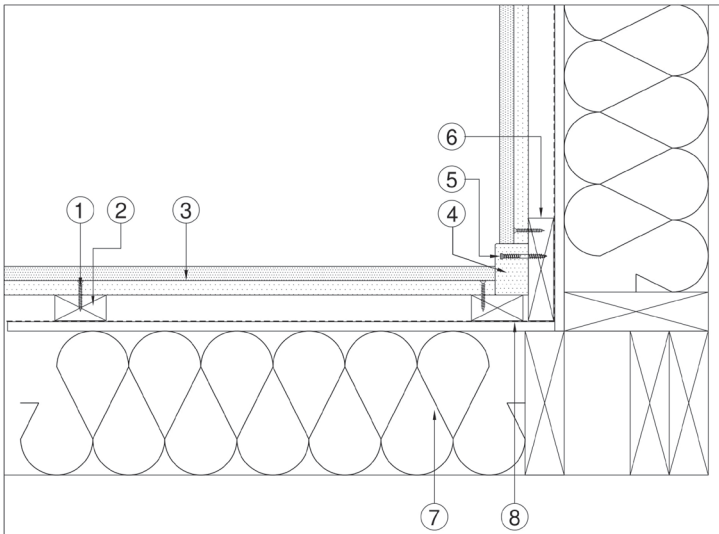

- | | |
|---|---|
| 1 - 30mm Cladding board fixing | 5 - Durafix 45mm fixing |
| 2 - Plas-Pro or Timber battens at 600mm centres | 6 - Plas-Pro or timber batten |
| 3 - Envello Board & Batten cladding board | 7 - Example structural timber & sheathing or masonry wall |
| 4 - Square edging | 8 - Breather membrane |

Note: If treated timber battens are being used, we would recommend putting a strip of DPC, joist tape or epdm on to the front of the battens

342.

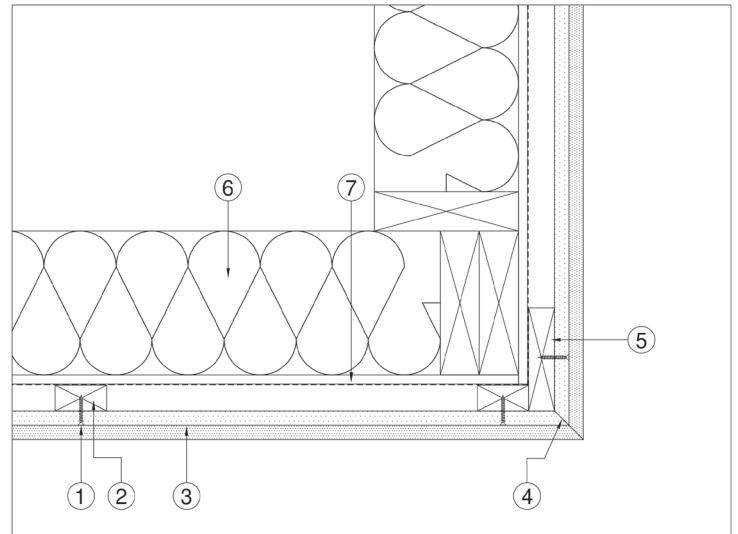

- | | |
|---|---|
| 1 - 30mm Cladding board fixing | 5 - Plas-Pro or timber batten |
| 2 - Plas-Pro or Timber battens at 600mm centres | 6 - Example structural timber & sheathing or masonry wall |
| 3 - Envello Board & Batten cladding board | 7 - Breather membrane |
| 4 - Mitred joint to be glued together, PU wood glue to be used for the core and superglue for the Lastane surface | |

Note: If treated timber battens are being used, we would recommend putting a strip of DPC, joist tape or epdm on to the front of the battens

millboard.co.uk

© 2021 The Millboard Company Ltd., Millboard®, Lastane®, Durafix®, Lasta-Grip®, DuoSpan®, DuoLift® and the phrase "Live. Life. Outside.™" are protected trademarks. Patents and Patents Pending apply to Millboard® products. The company will vigorously defend its patent rights. Due to printing restraints, actual colours may vary from those shown in brochure. This brochure is not to be reproduced or copied without written permission from Millboard directors. Millboard has a policy of continual improvement to specification. Product blend, colours and sizes may change without notice. All sizes and measurements are nominal. Information is correct at time of going to press. Patent numbers include GB 2445714, GB 2449184, USA 8,065,849, CAN 2664329, EU 1951971.

The Millboard Company Ltd
UK Head Office
Unit A, Castle Court
Bodmin Road
Coventry CV2 5DB

T +44 (0) 24 7643 9943
F +44 (0) 24 7661 1668
E enquiries@millboard.co.uk

Company registered No. 06061318
VAT No: 980 616602

