

Yolanda showed us that the way we build houses needs to be stronger. These are 8 key messages on how to repair your house and build back safer.

1 BUILD ON STRONG FOUNDATIONS

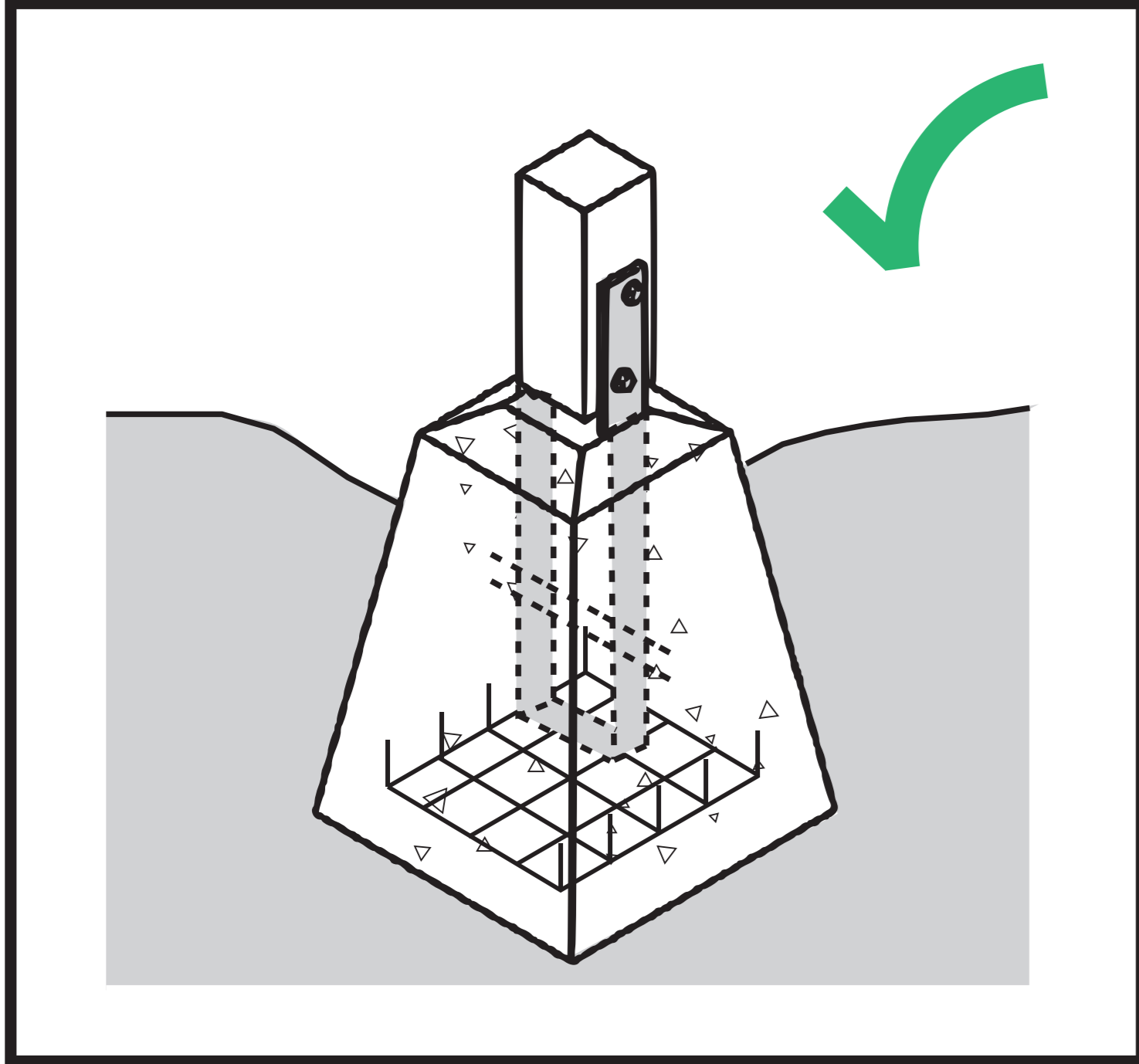

2 TIE-DOWN FROM BOTTOM UP

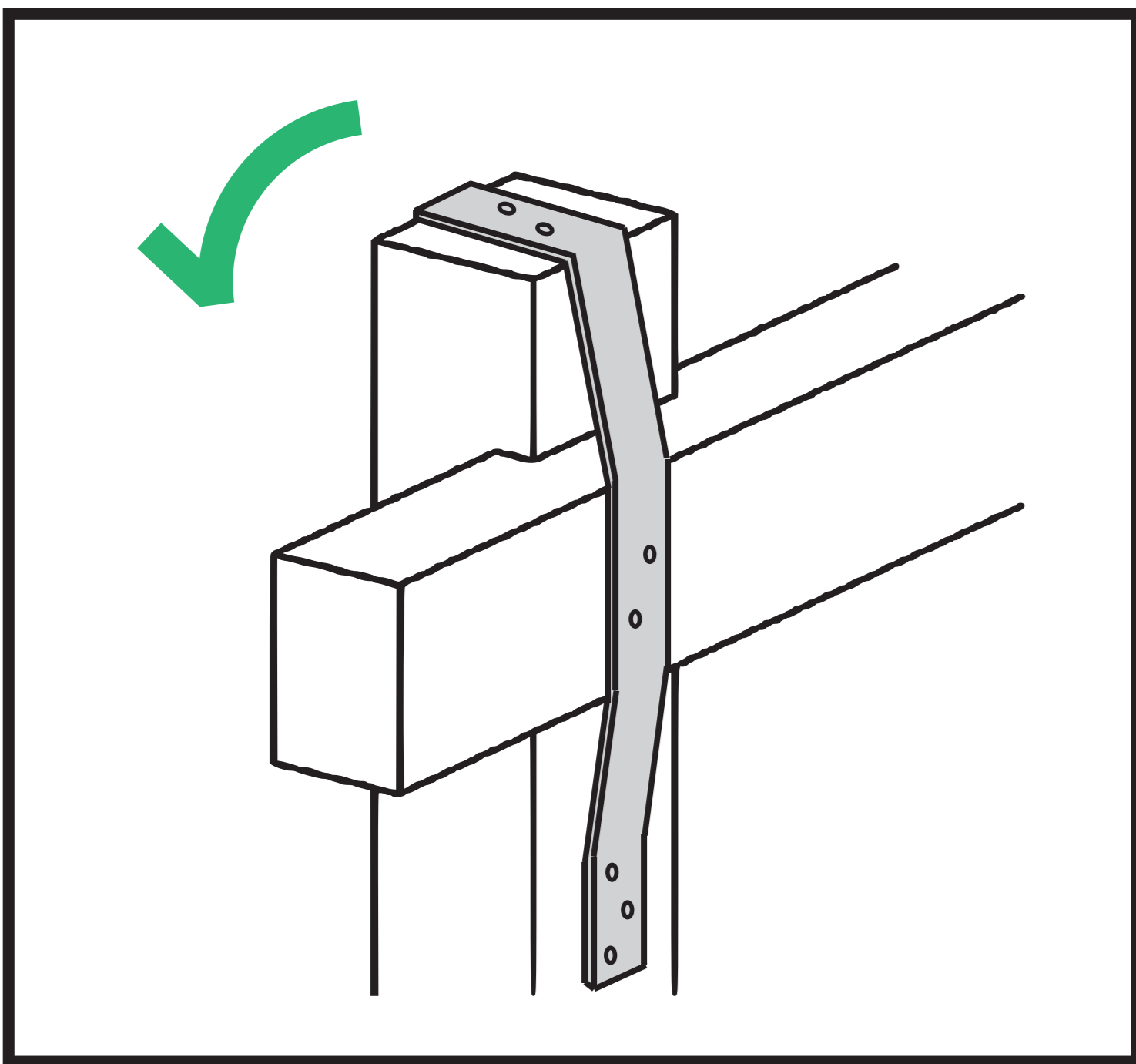

3 BRACE AGAINST THE STORM

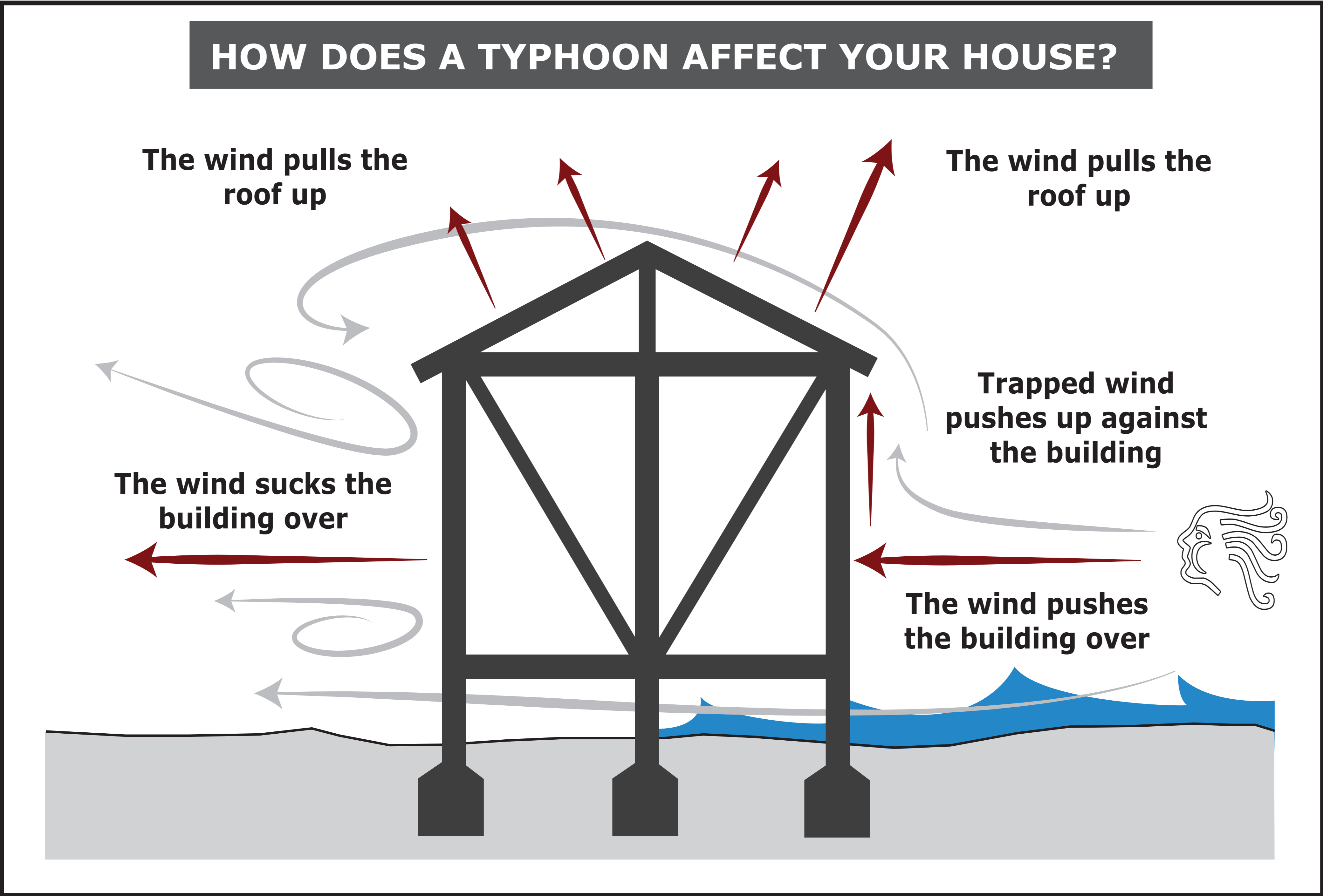
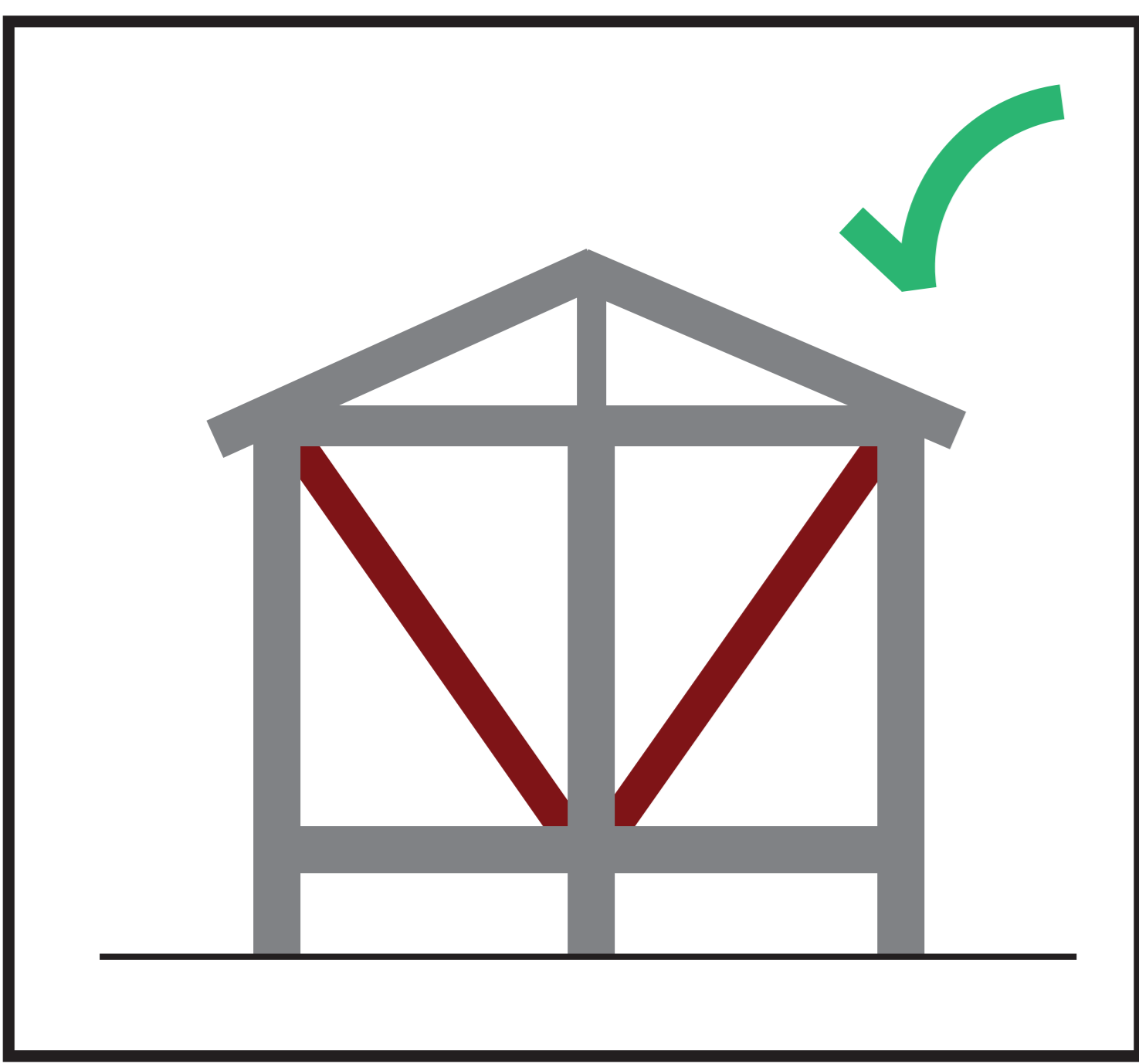

4 USE STRONG JOINTS

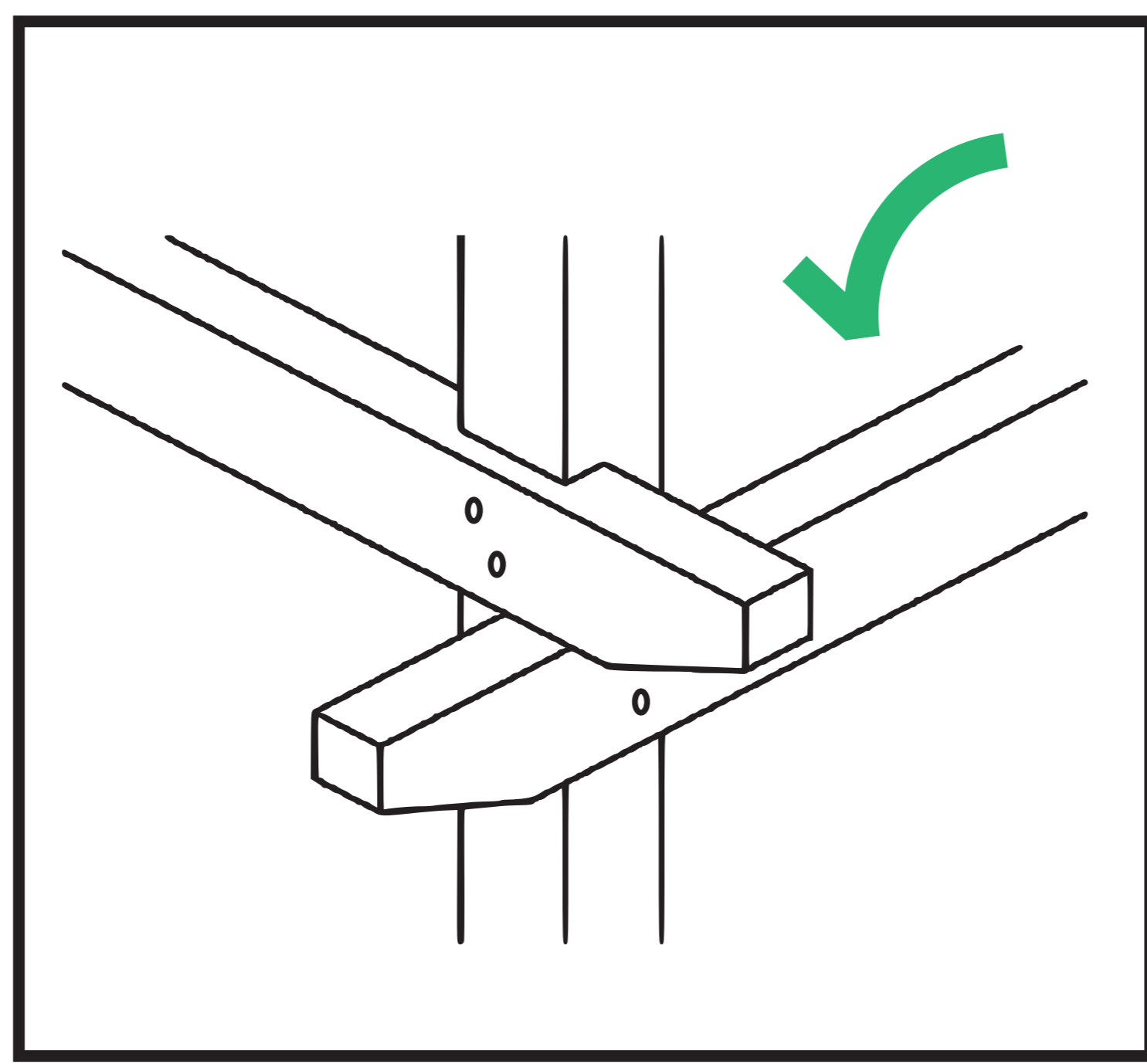

5 A GOOD HOUSE NEEDS A GOOD ROOF

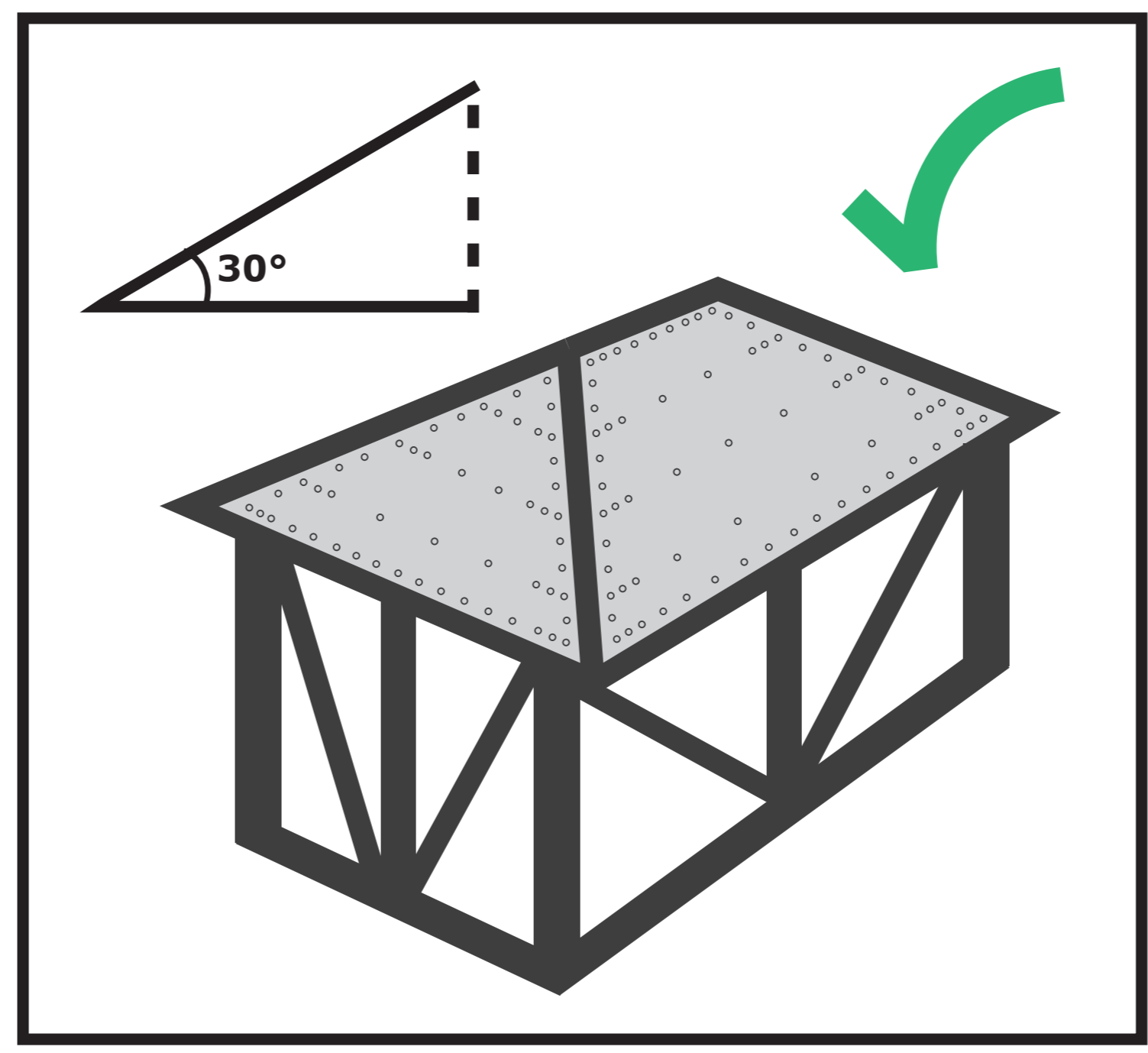

8 BE PREPARED

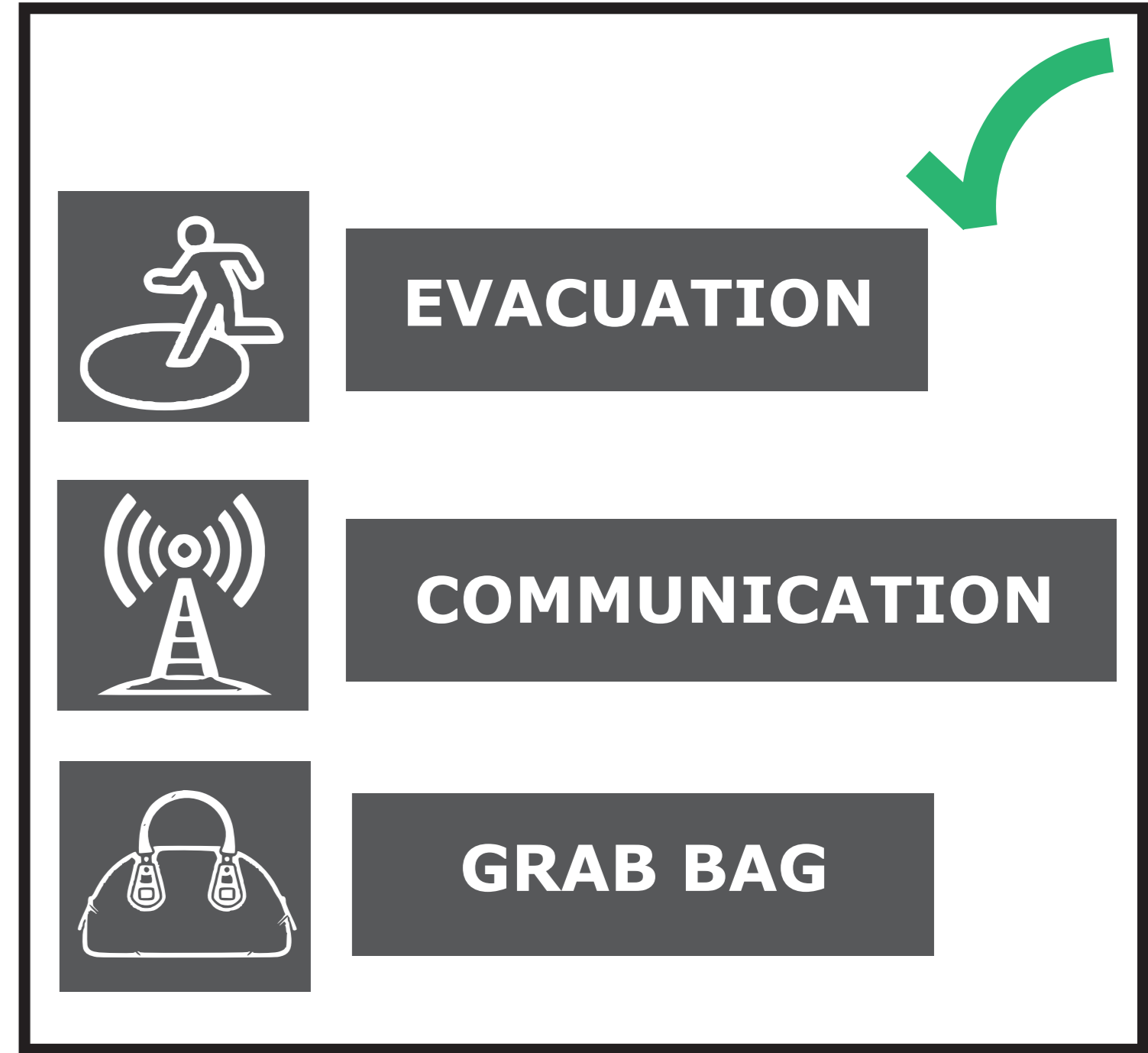

7 A SIMPLE SHAPE WILL KEEP YOU SAFE

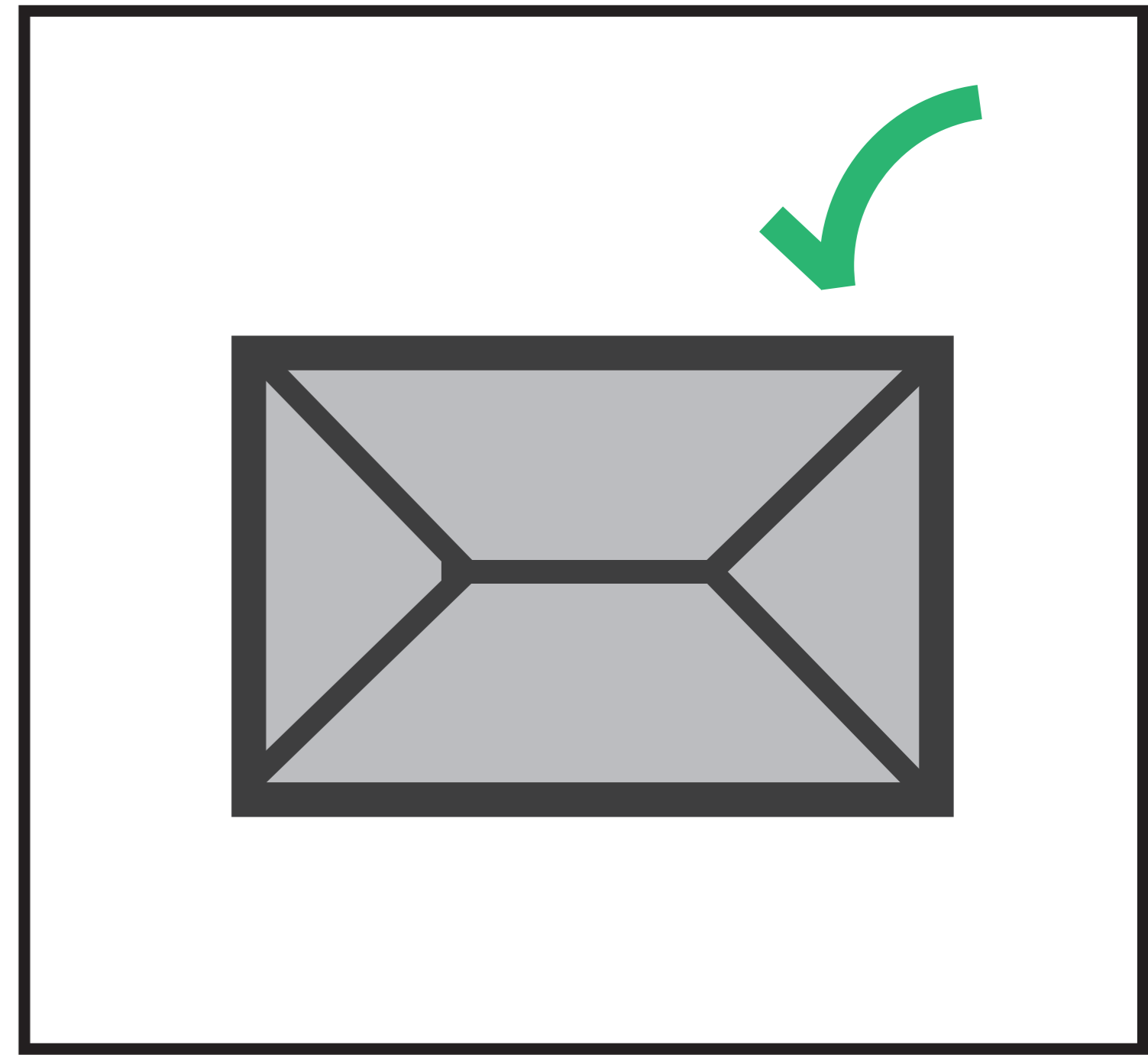

6 SITE YOUR HOUSE SAFELY

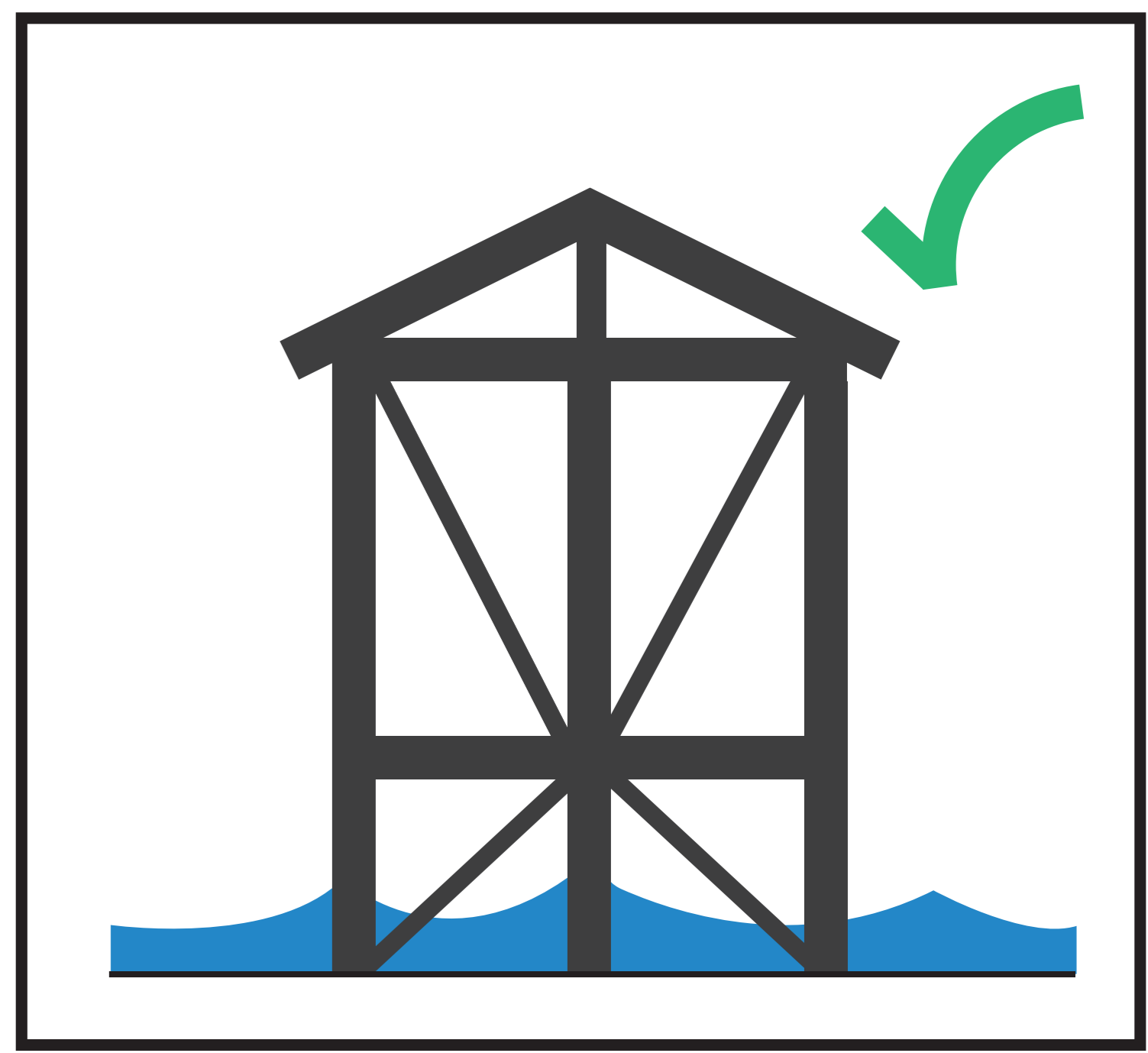

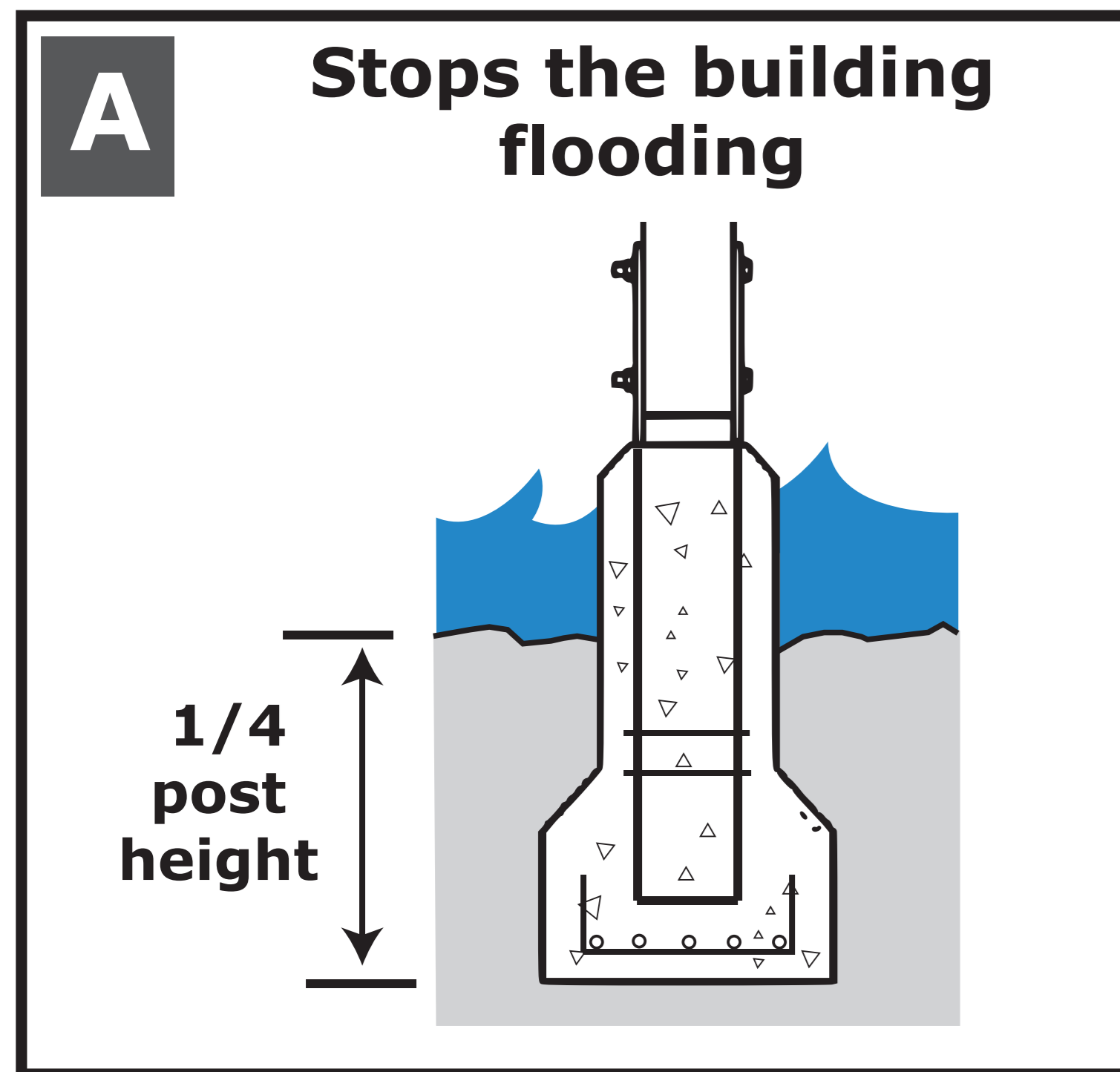

Build on strong foundations



Foundations are very important as they anchor your house to the ground. Ensuring foundations are suitable to your building's location and ground conditions protect your house from strong winds, earthquakes and flooding.

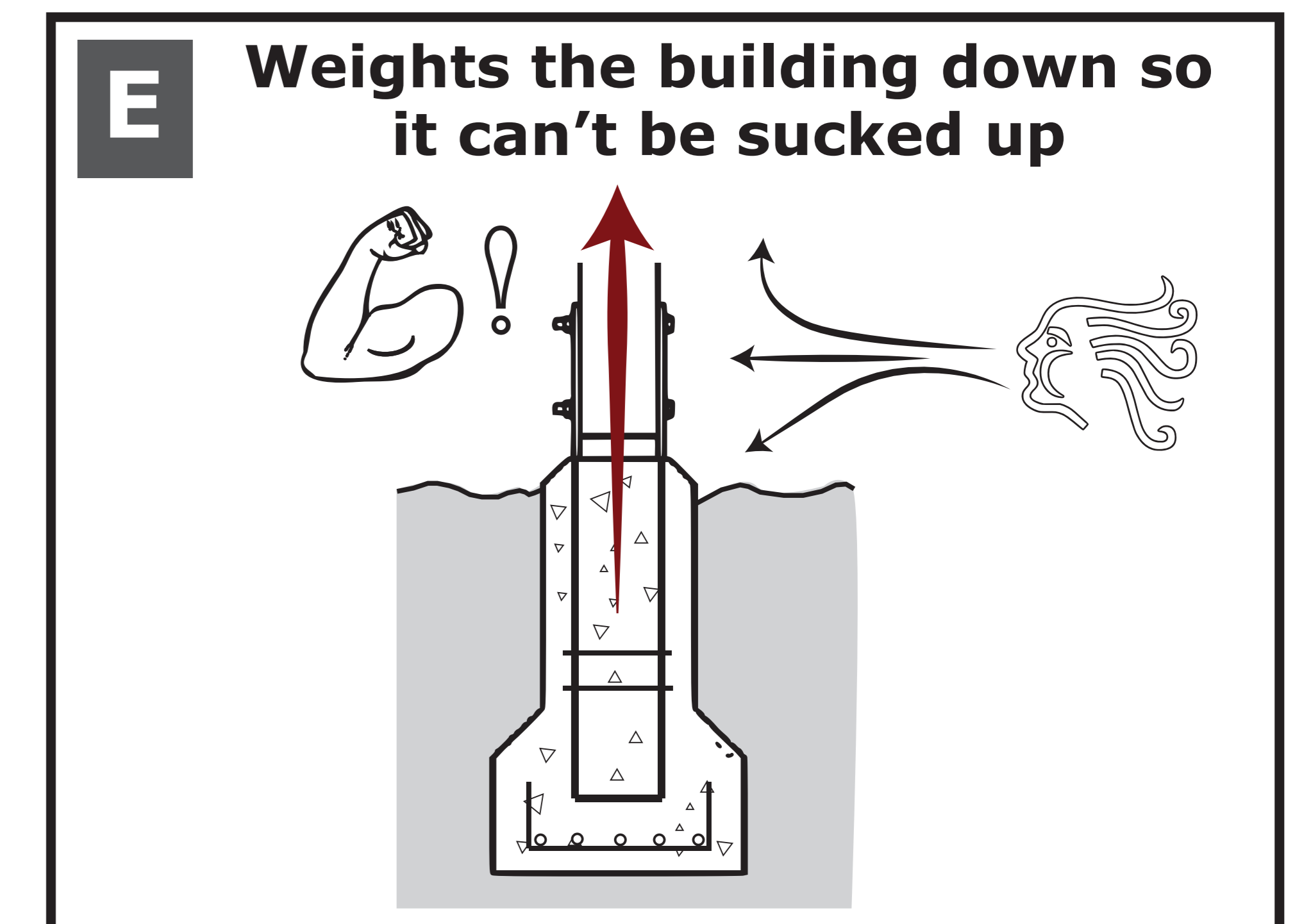
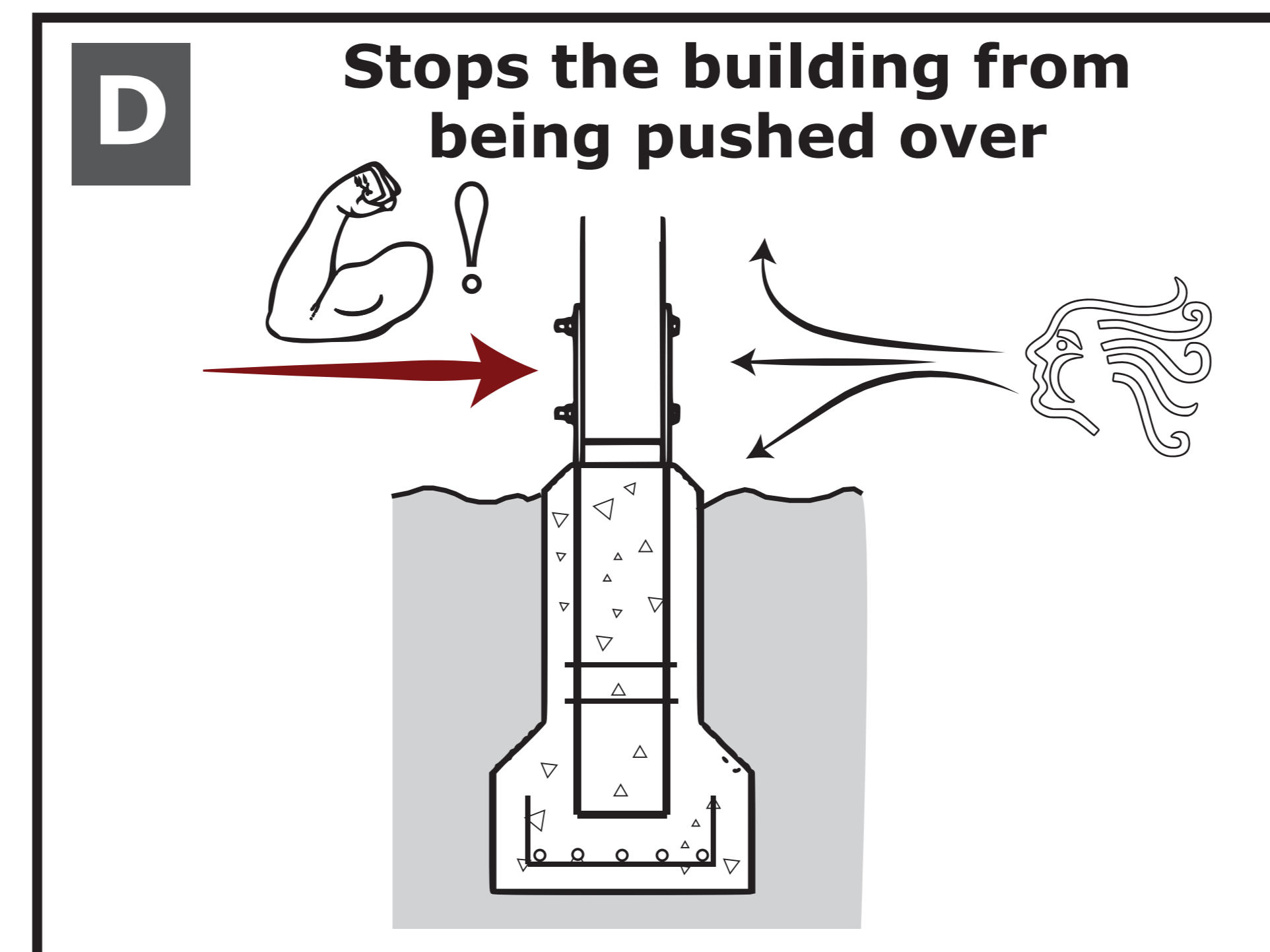
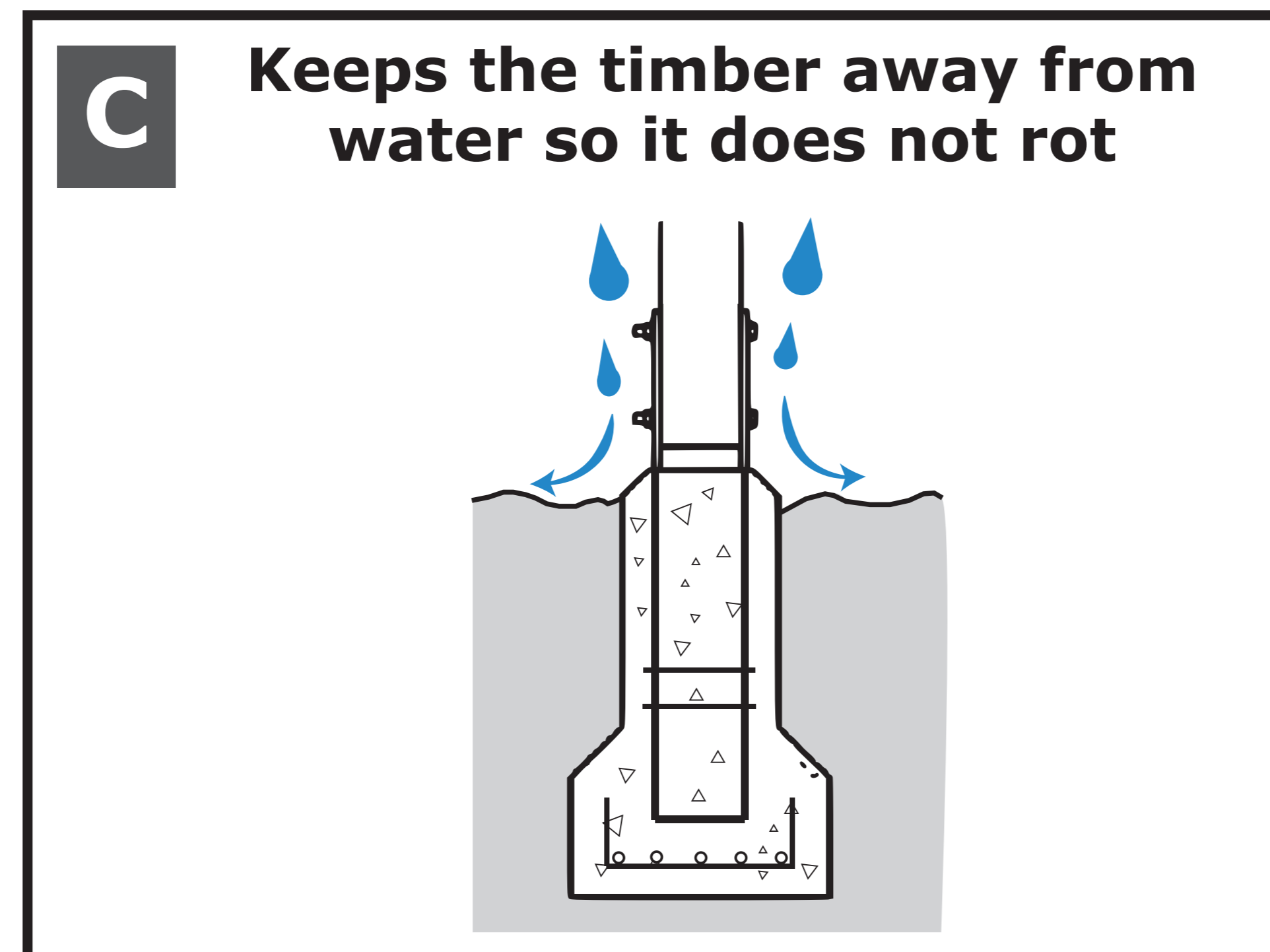
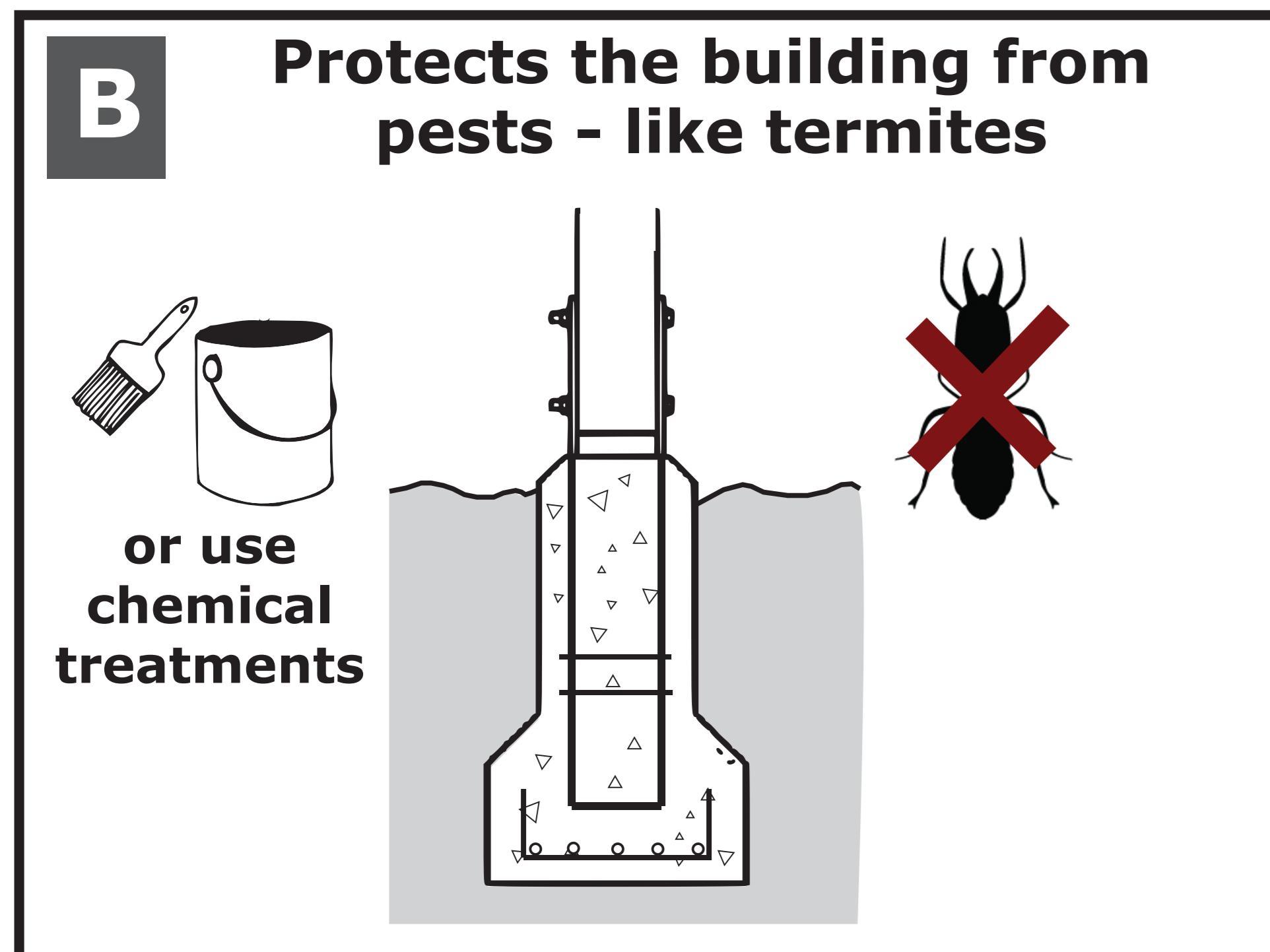
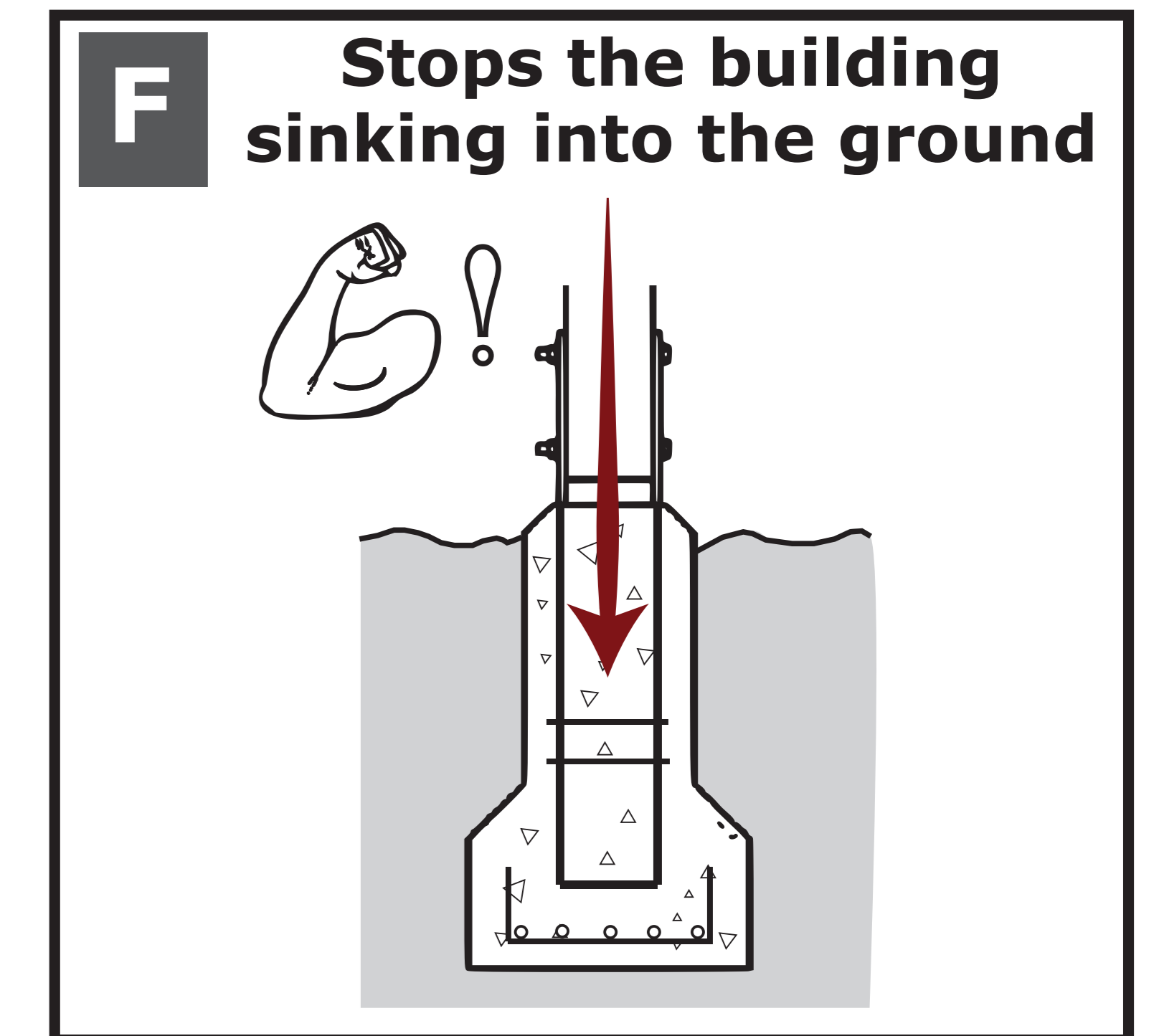

WHAT CAN I USE AS A FOUNDATION FOR MY HOUSE?

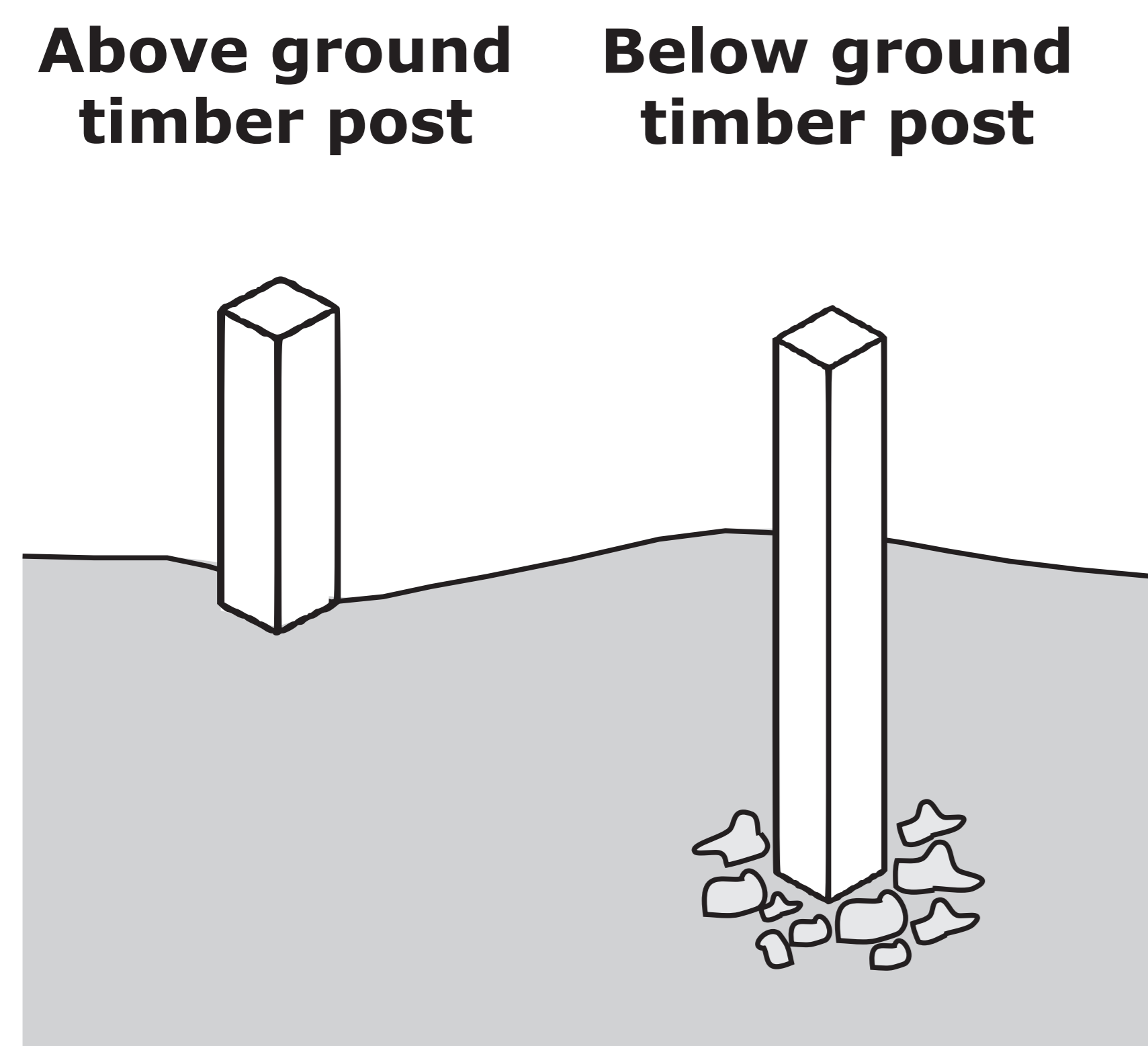

Too Weak **X**

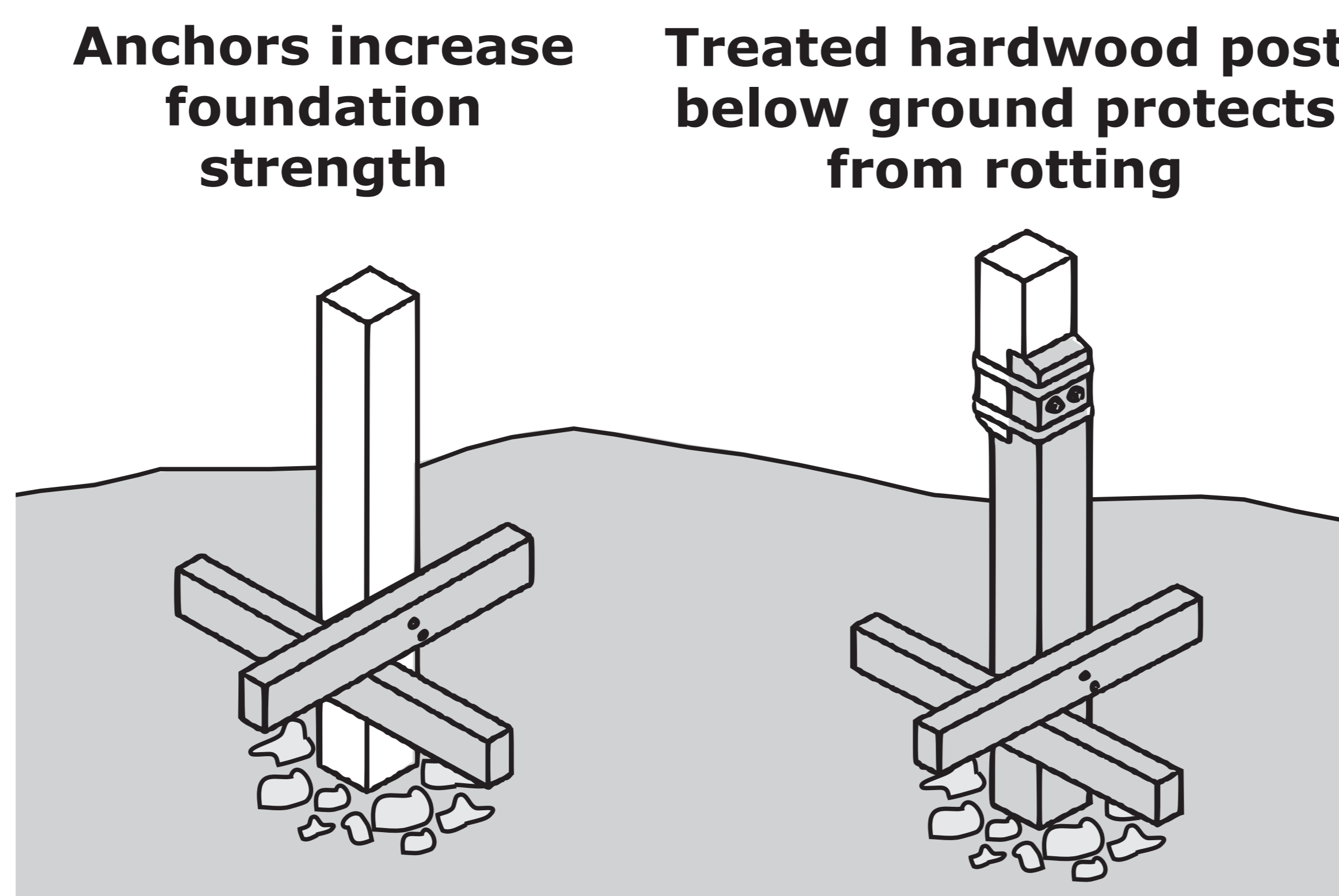

Strong **✓**

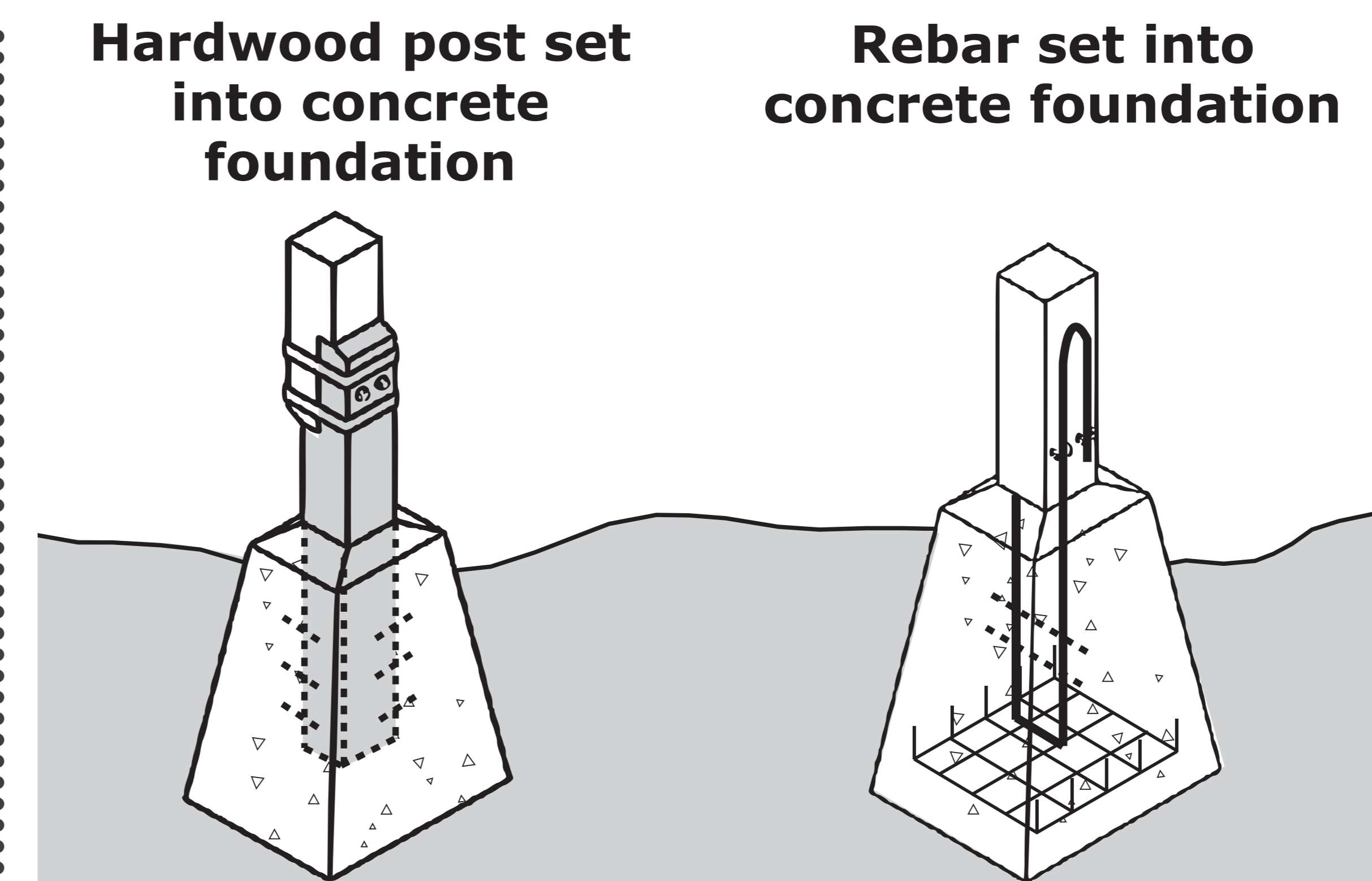

Stronger **✓**

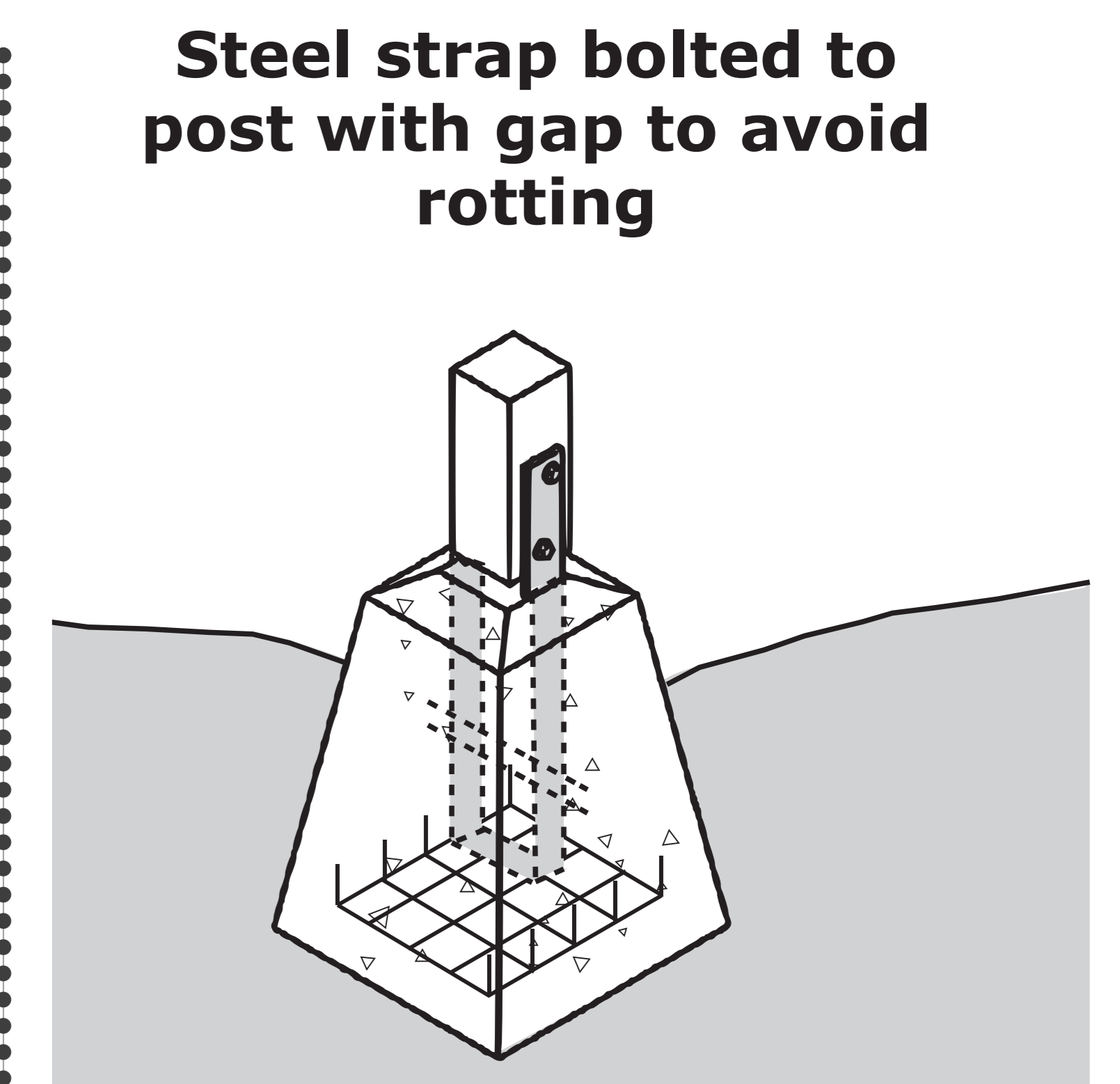

Strongest **✓✓**

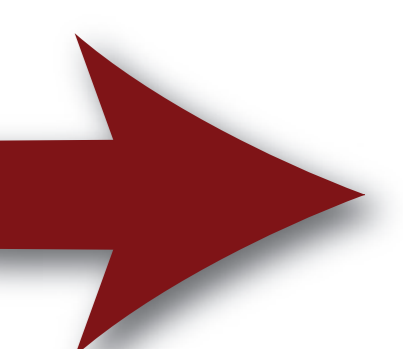

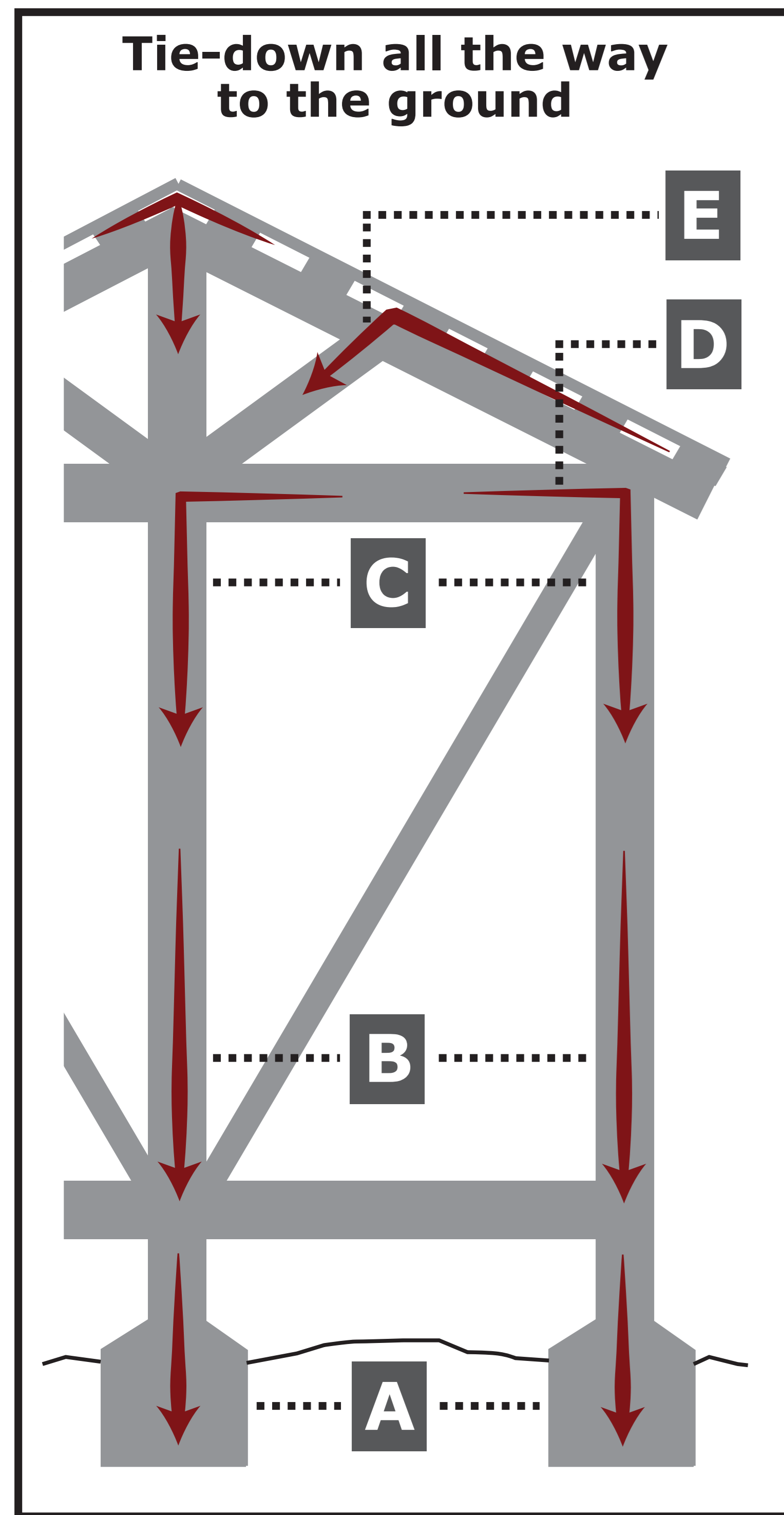

Tie-down from bottom up ✓

In a typhoon your house can be sucked apart or blown away by the wind. Tie every part of your building right through to the ground. Start thinking about this from the bottom up.

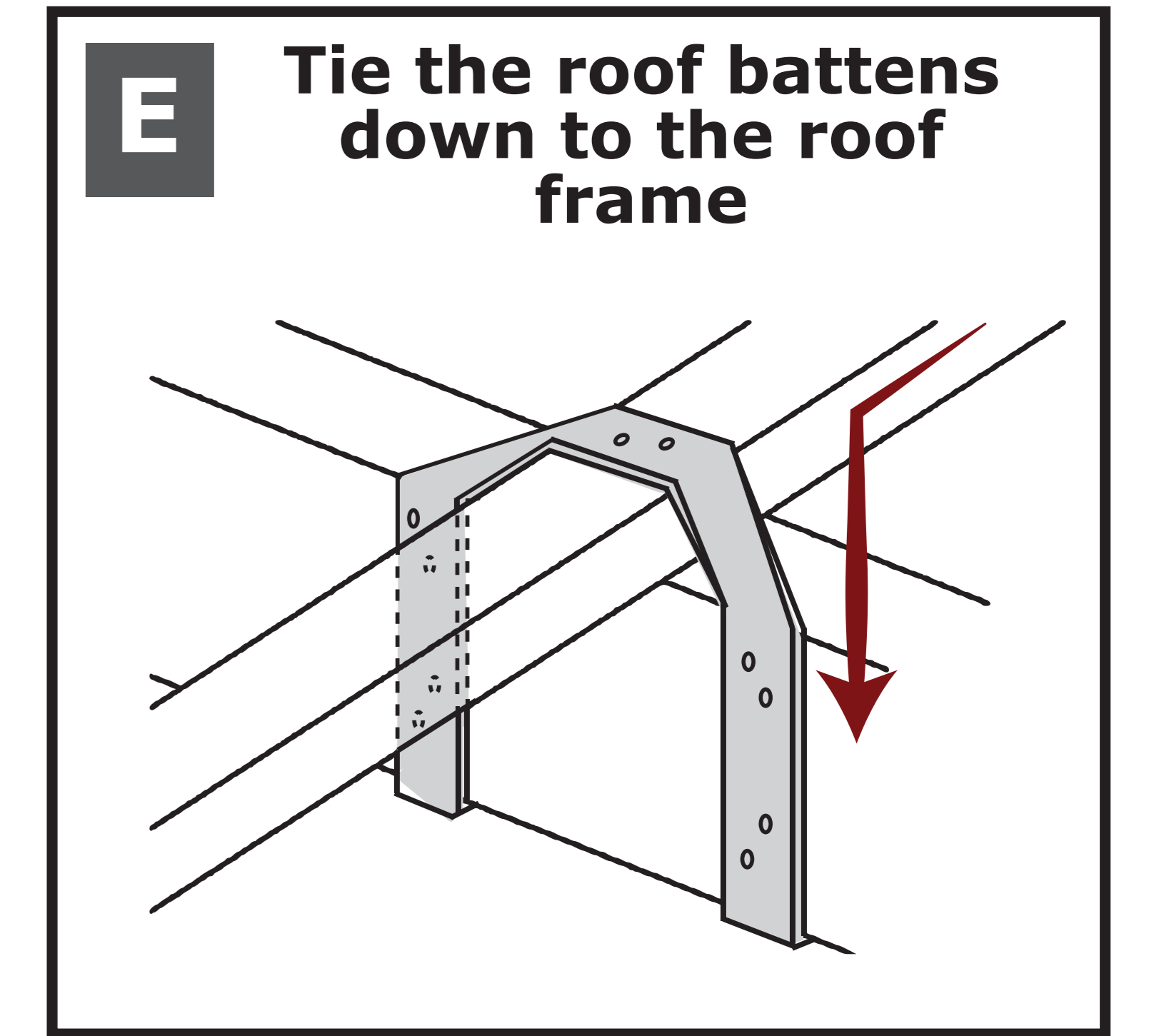
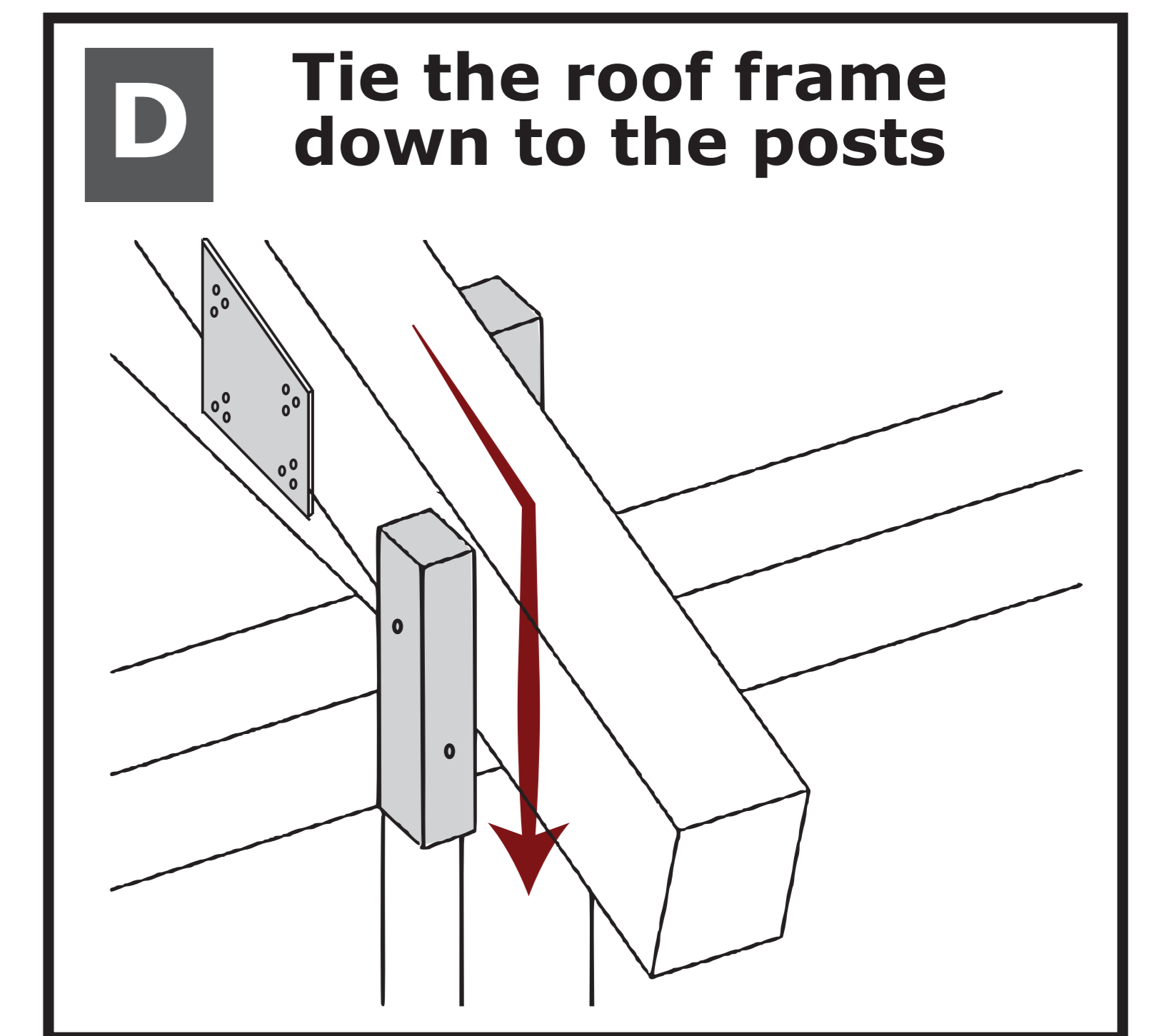
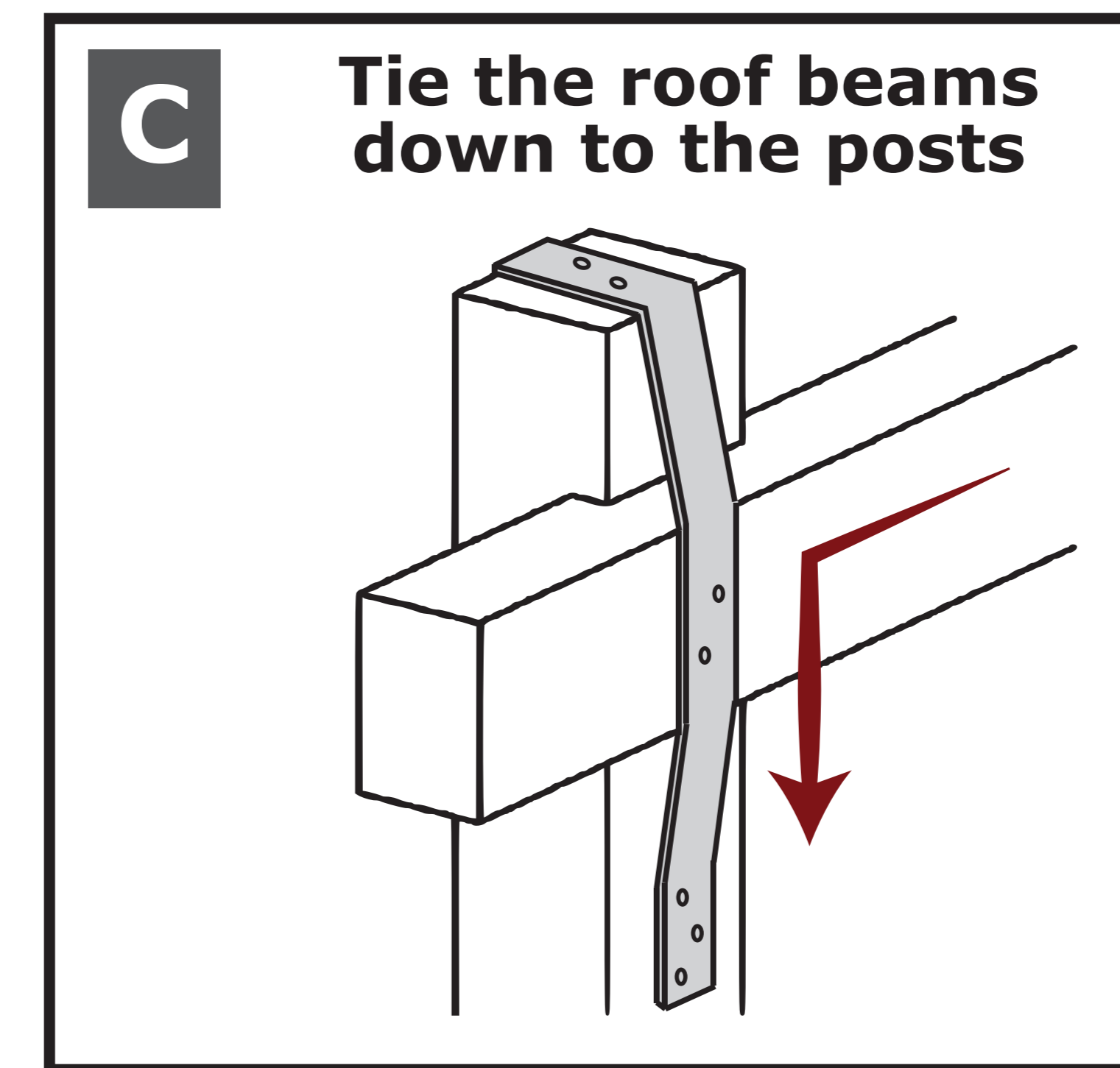
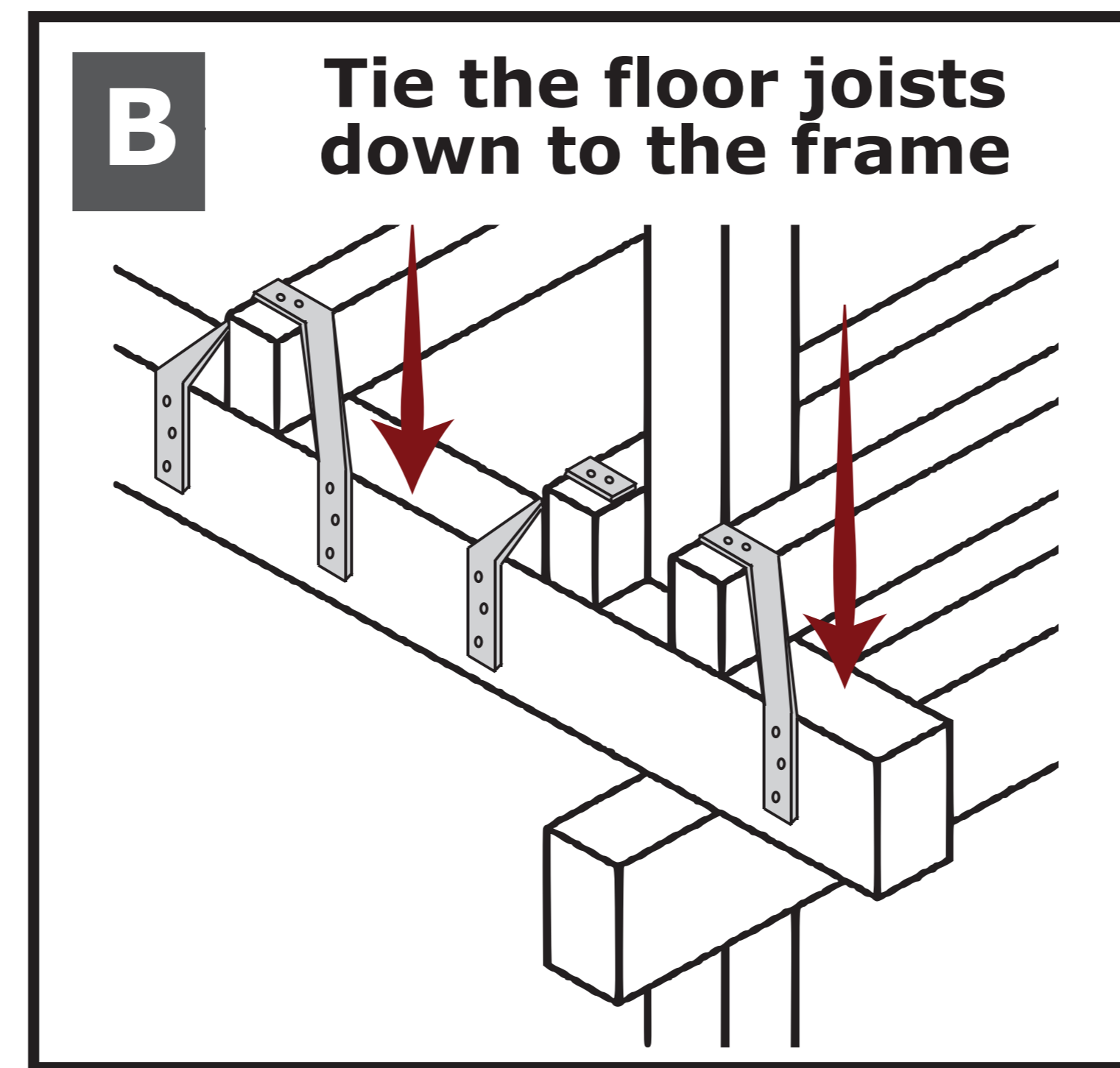
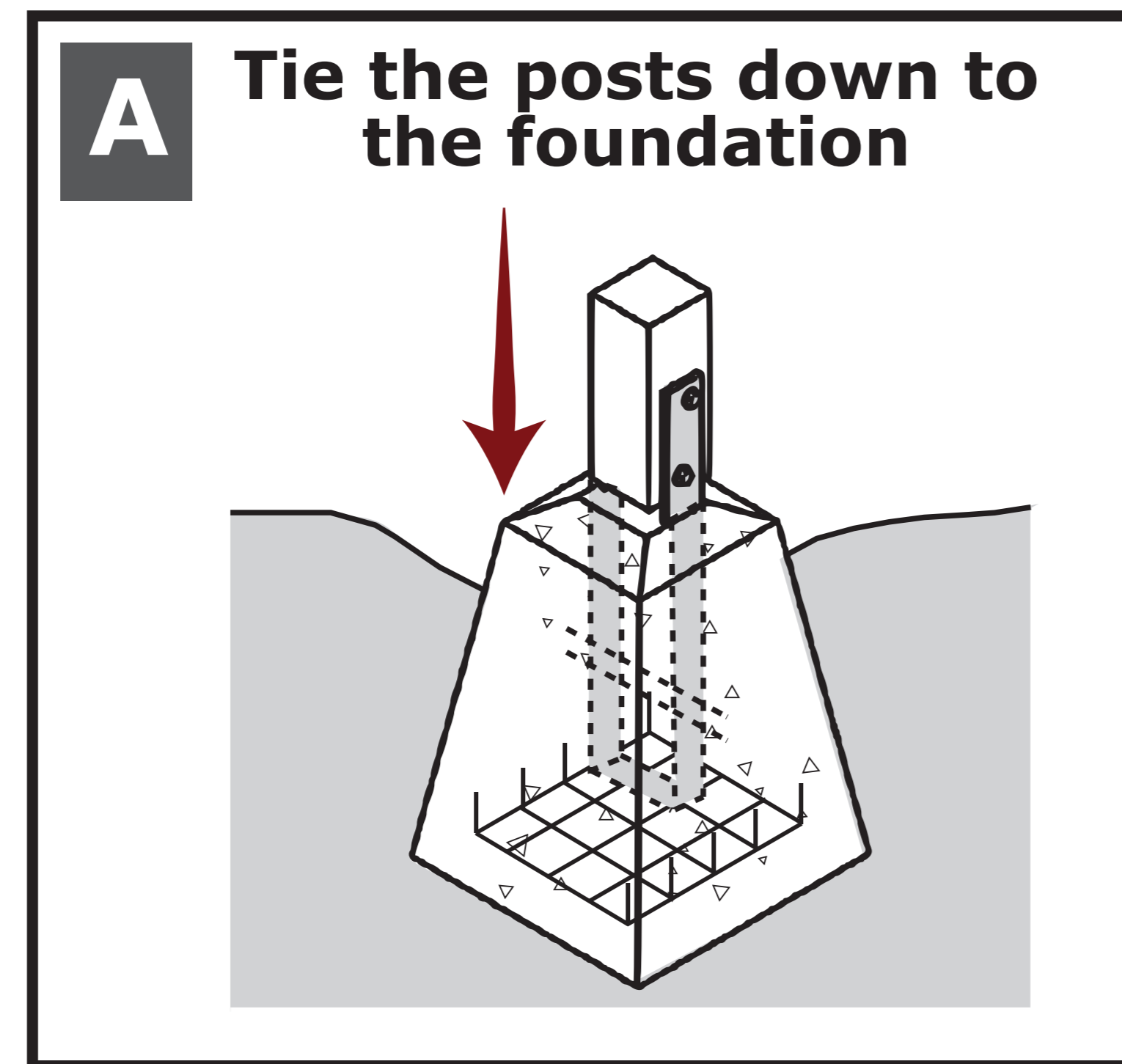

WHAT CAN I USE TO TIE-DOWN MY HOUSE?

STRONG WINDS COMING?

Rope or nylon fishing wire

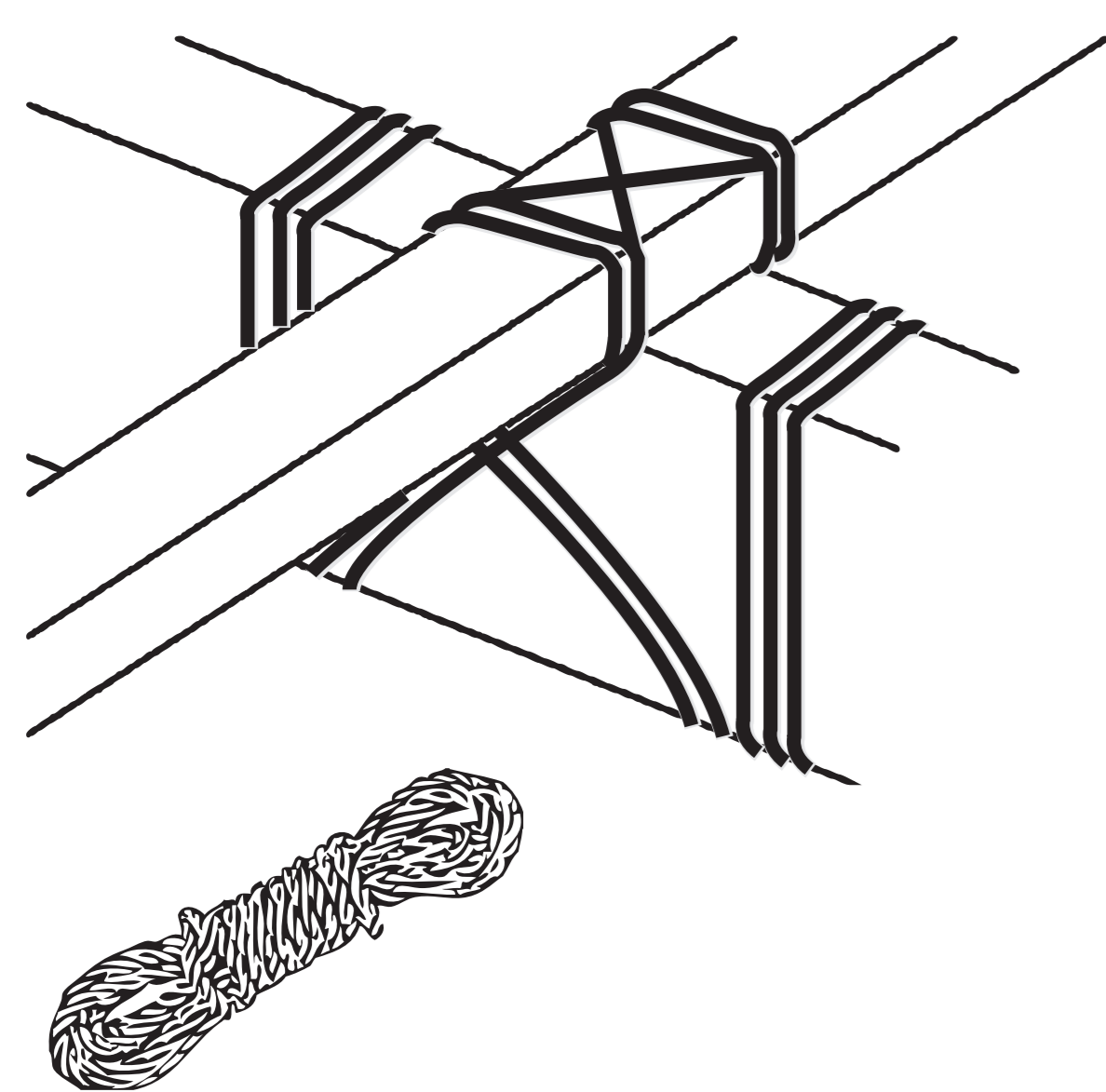

Thick galvanized wire (multiple layers)

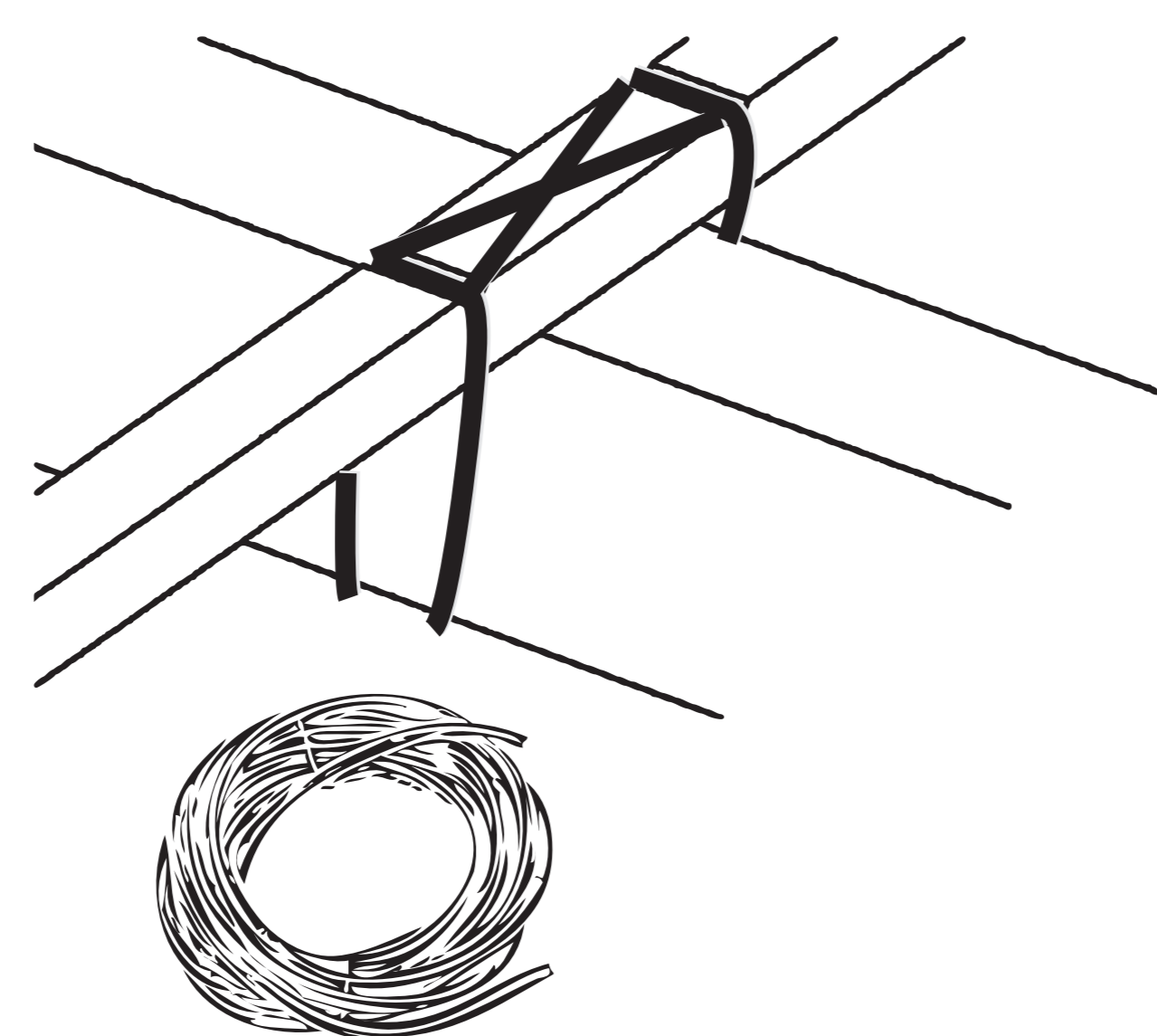

Strong ✓

Timber cleats

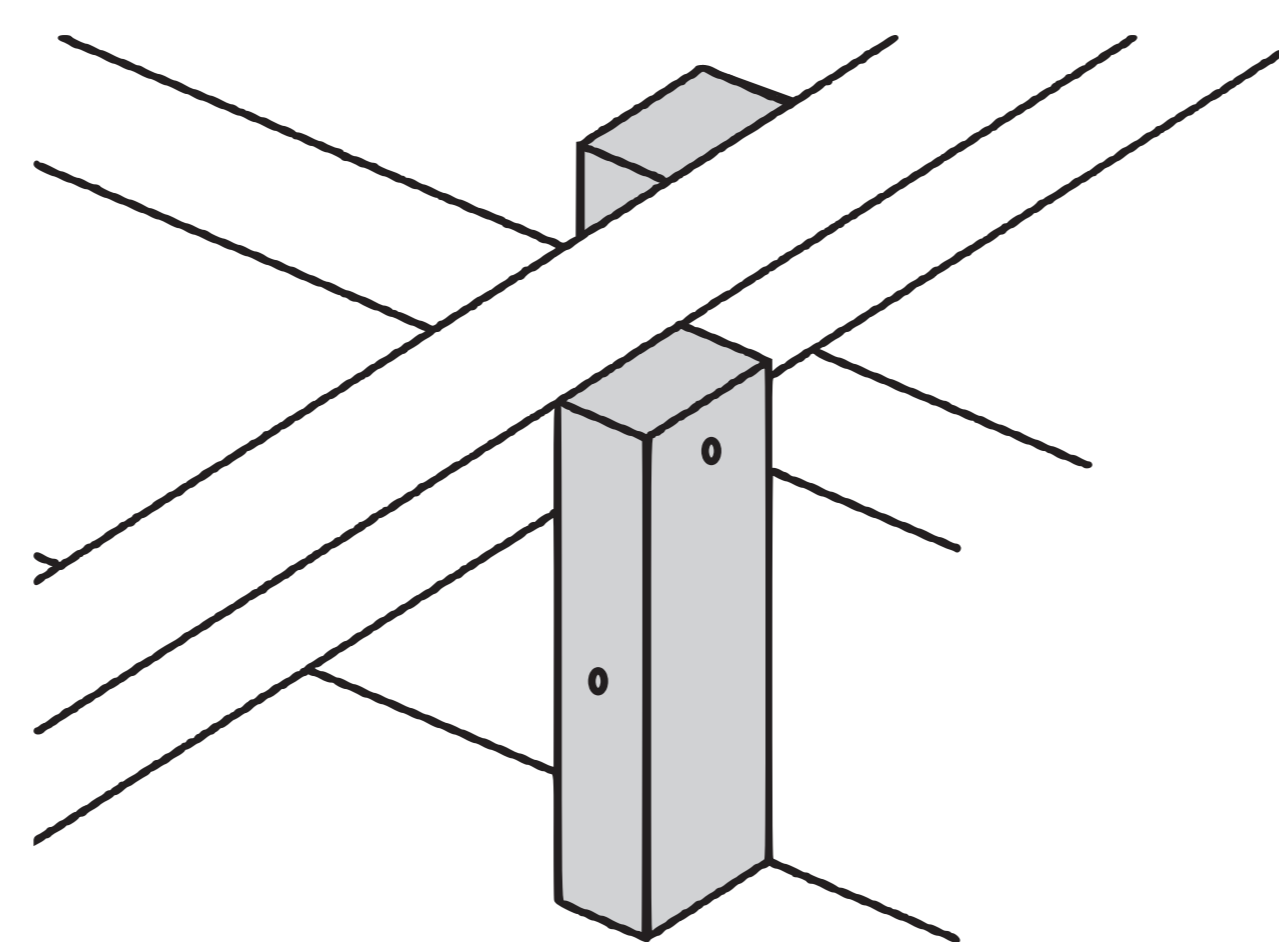

Galvanized metal strap

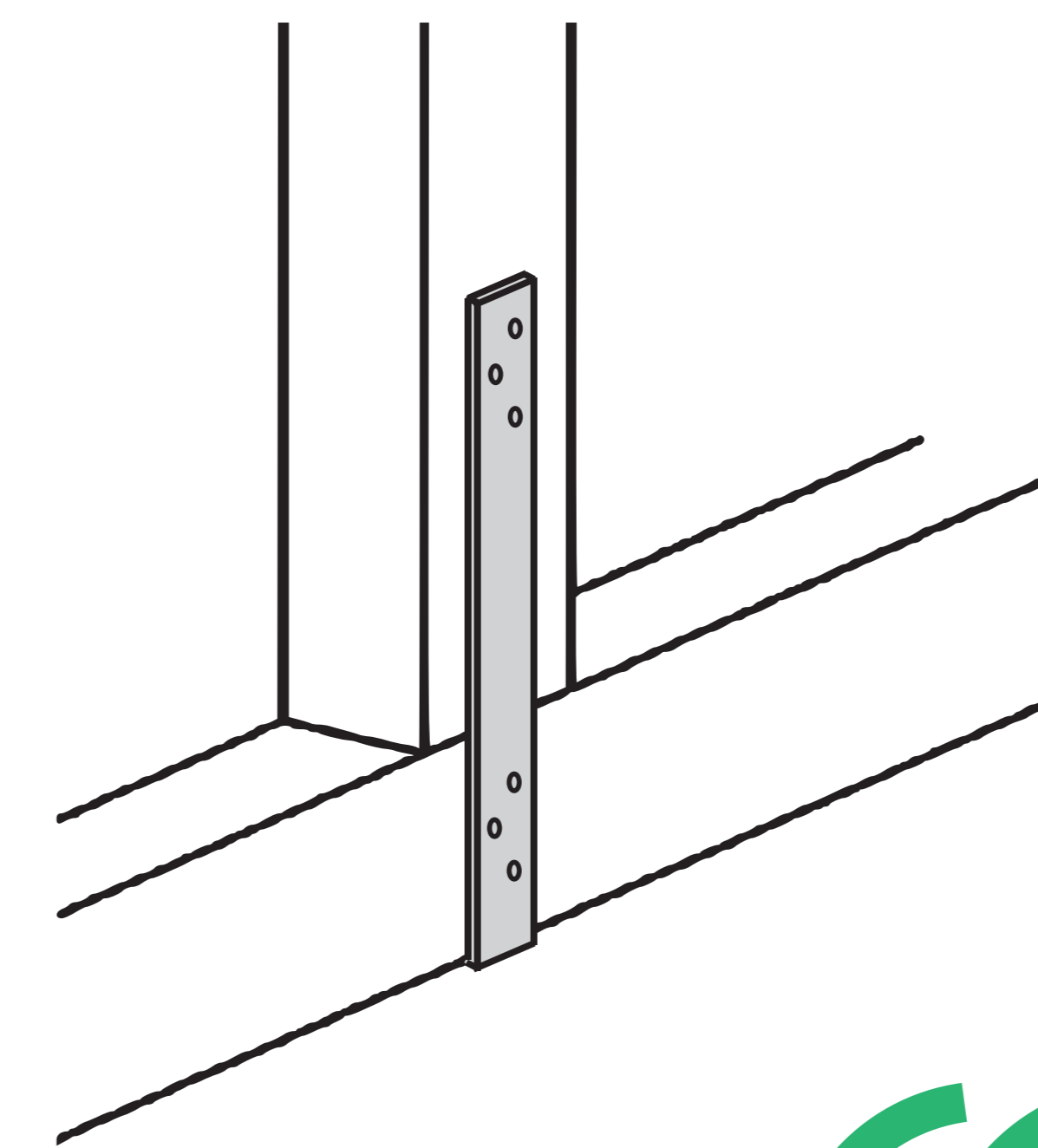

Strongest ✓✓

Tie-down when strong winds come

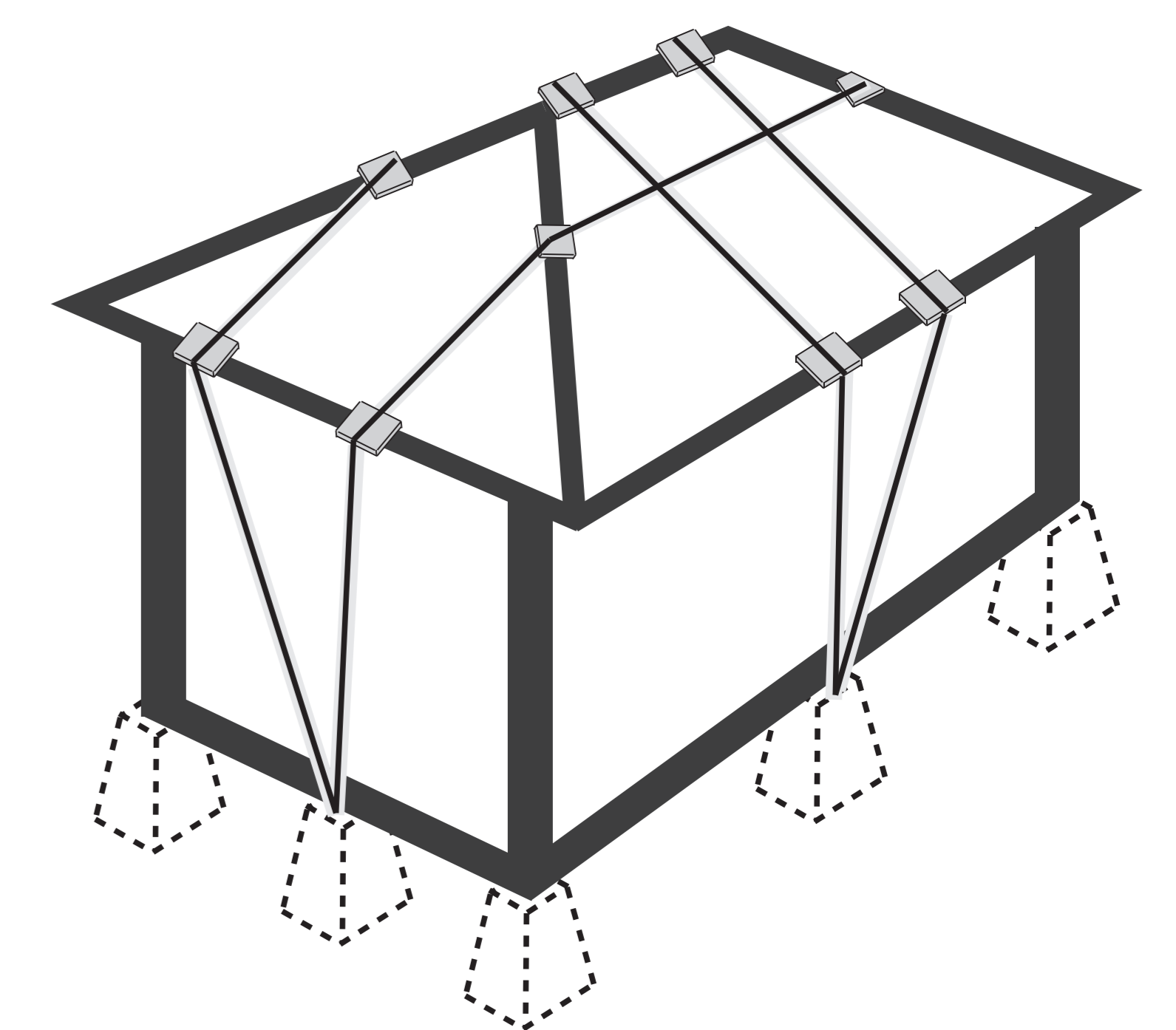

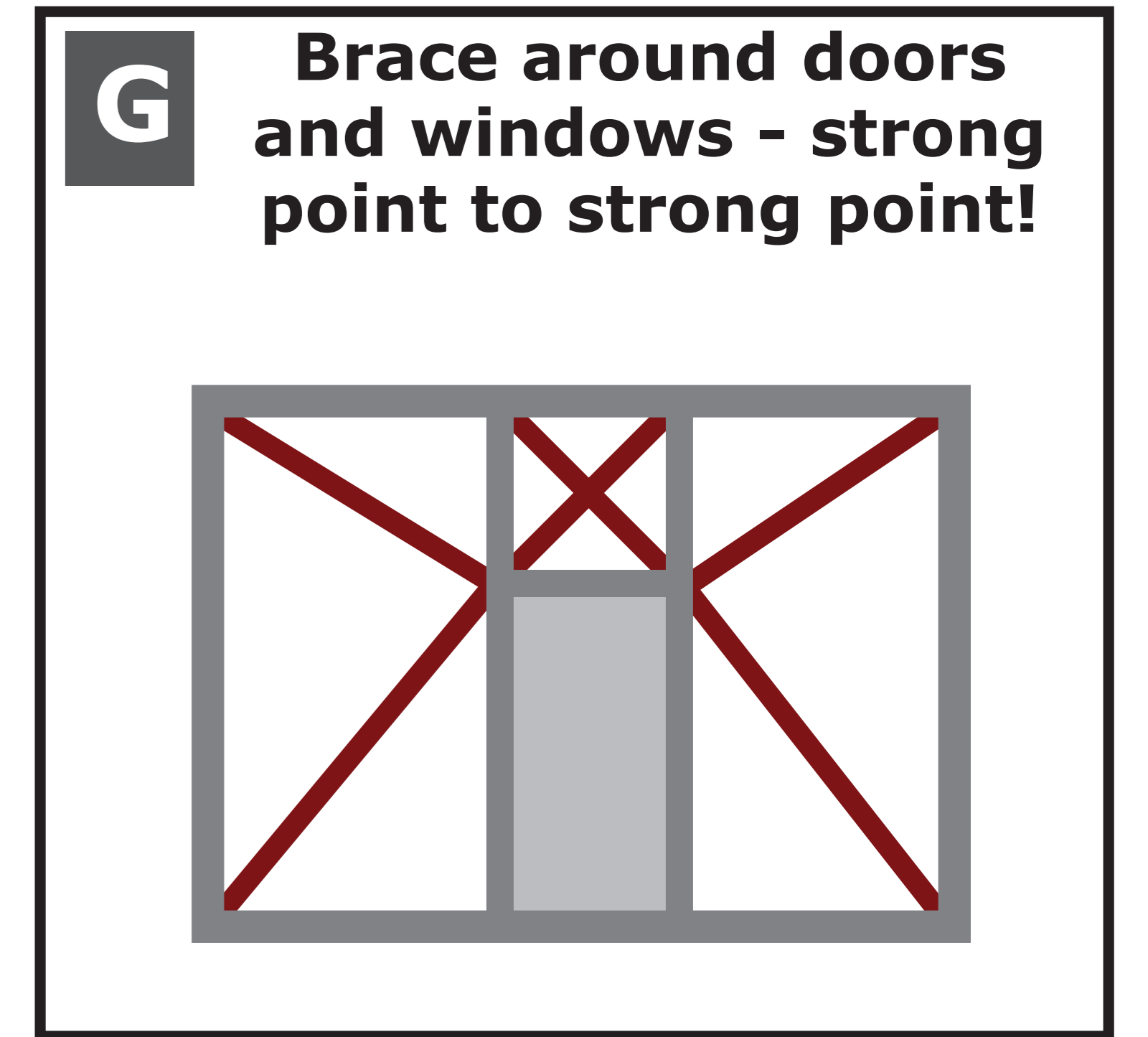
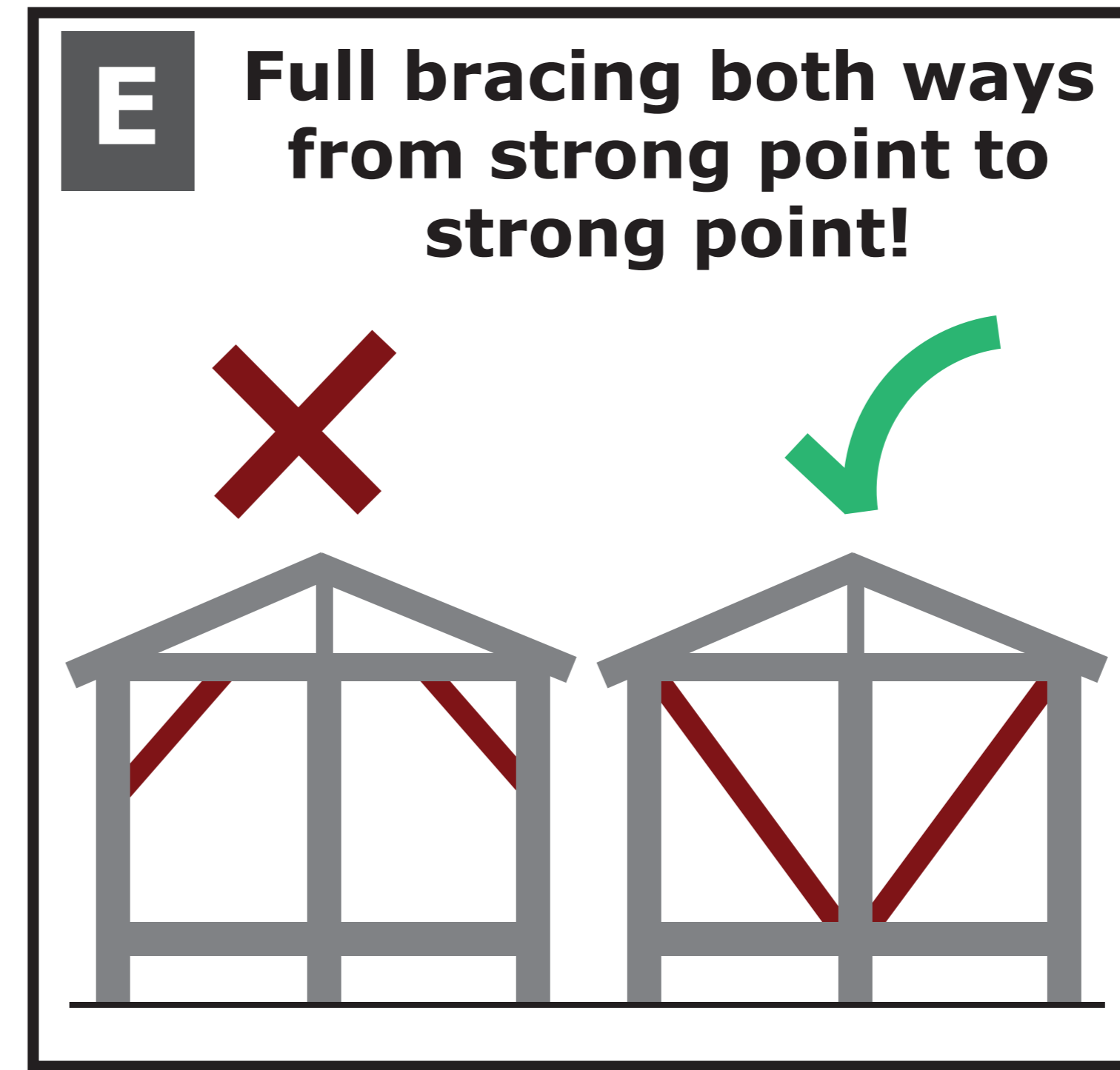
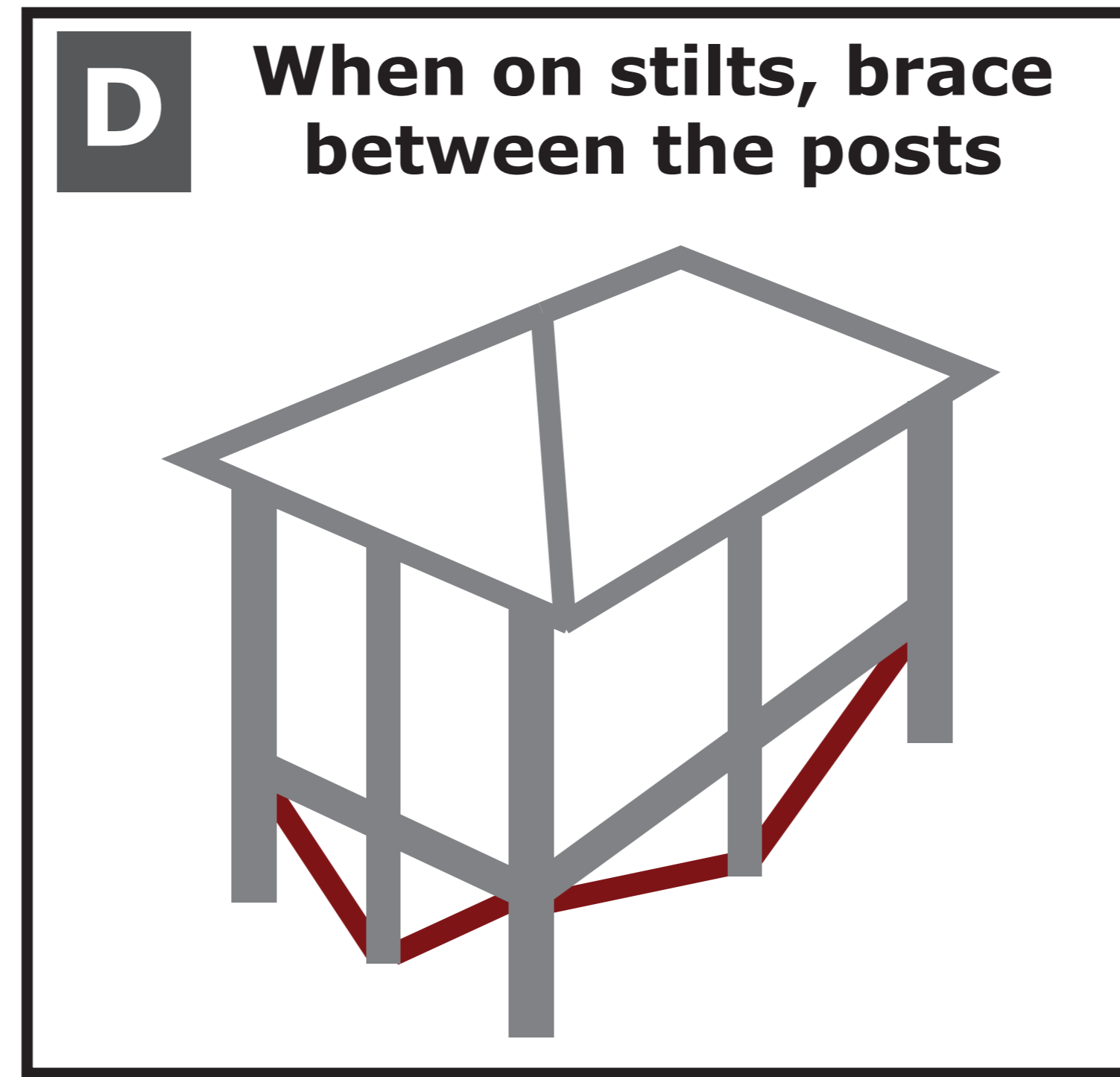
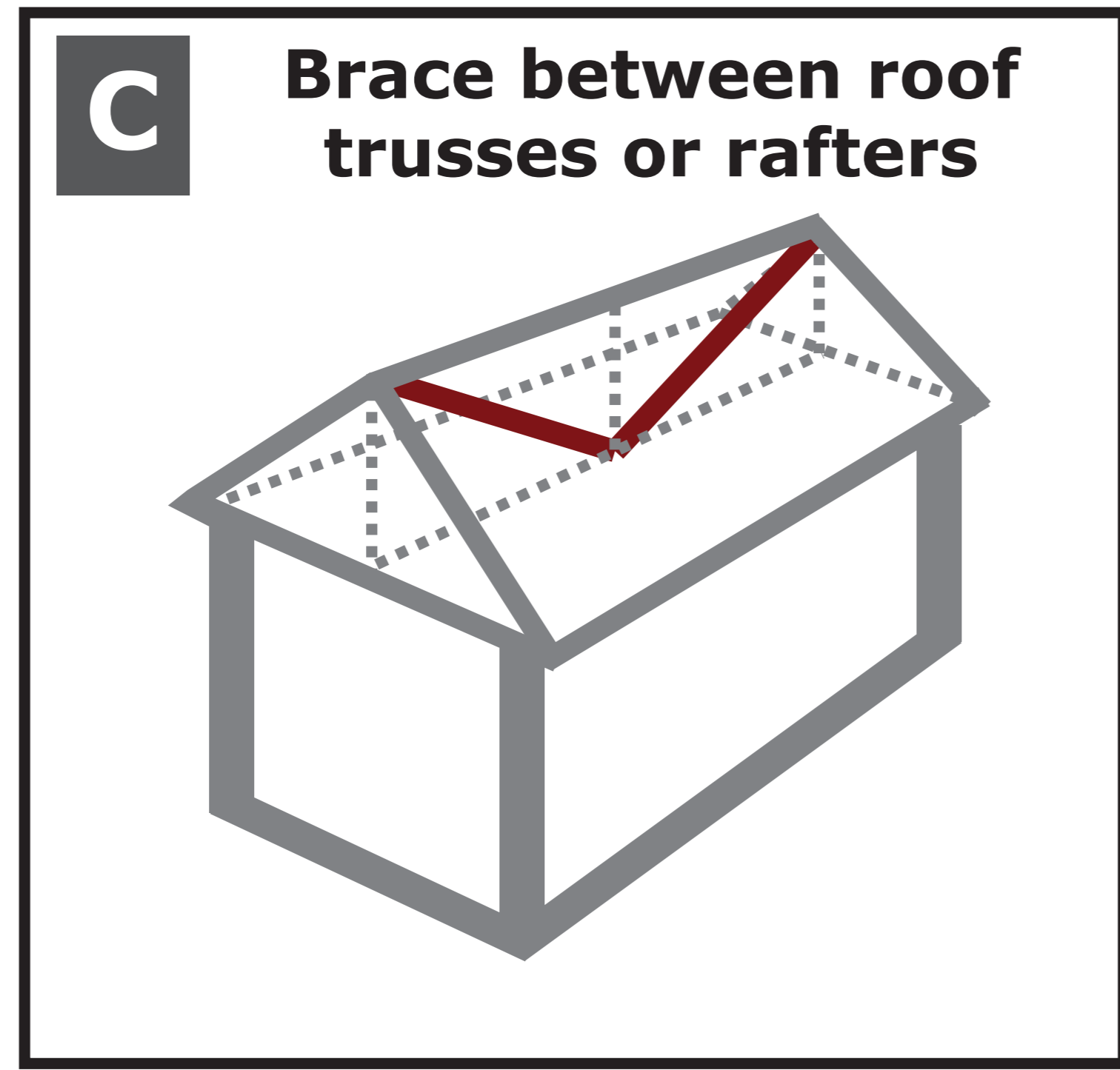
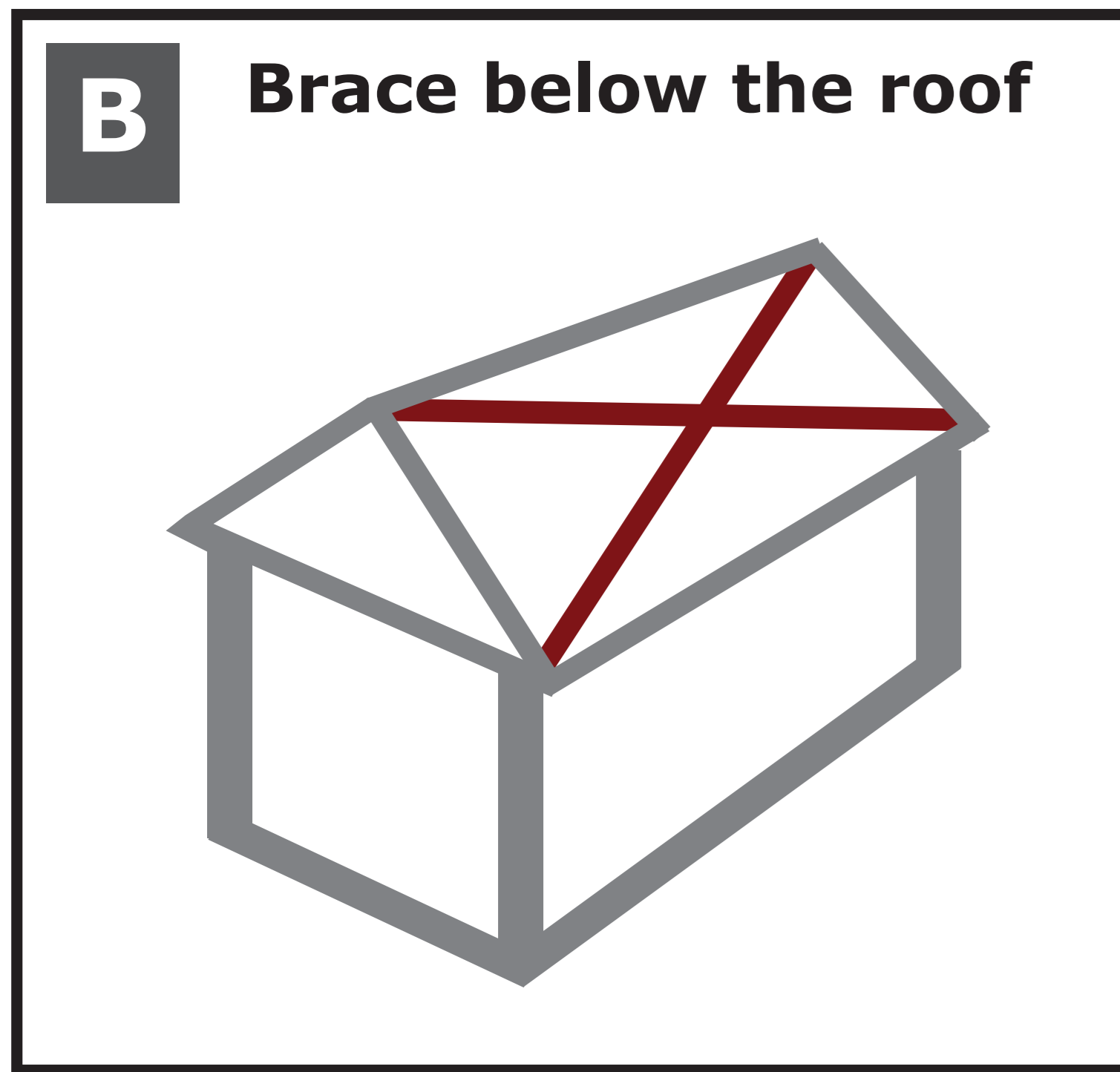
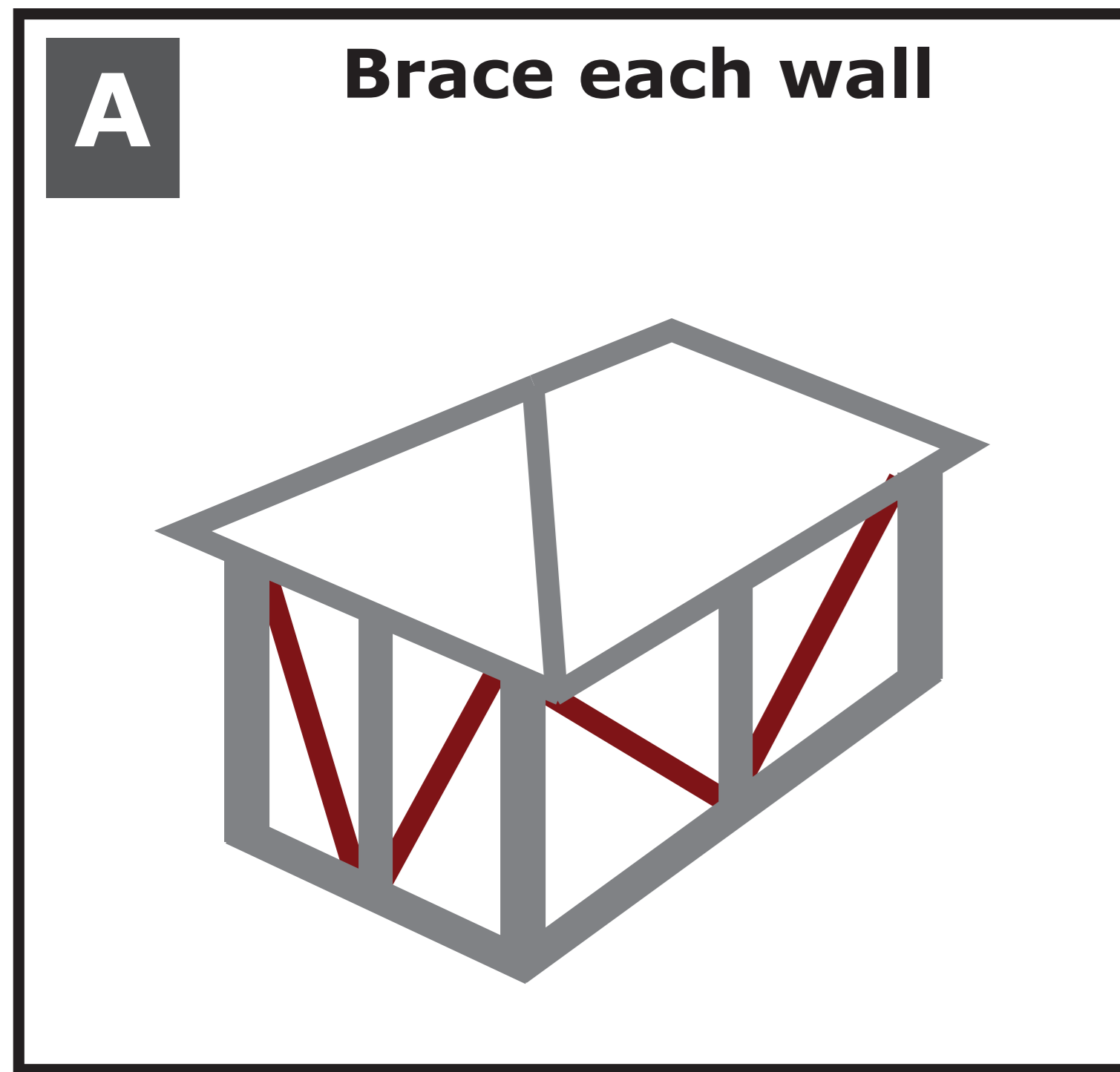

Brace against the storm

Strong bracing stops your house being pushed over or pulled apart by the wind. Bracing needs to be strong against being crushed along its length or pulled apart. Brace between the strong points of your house.

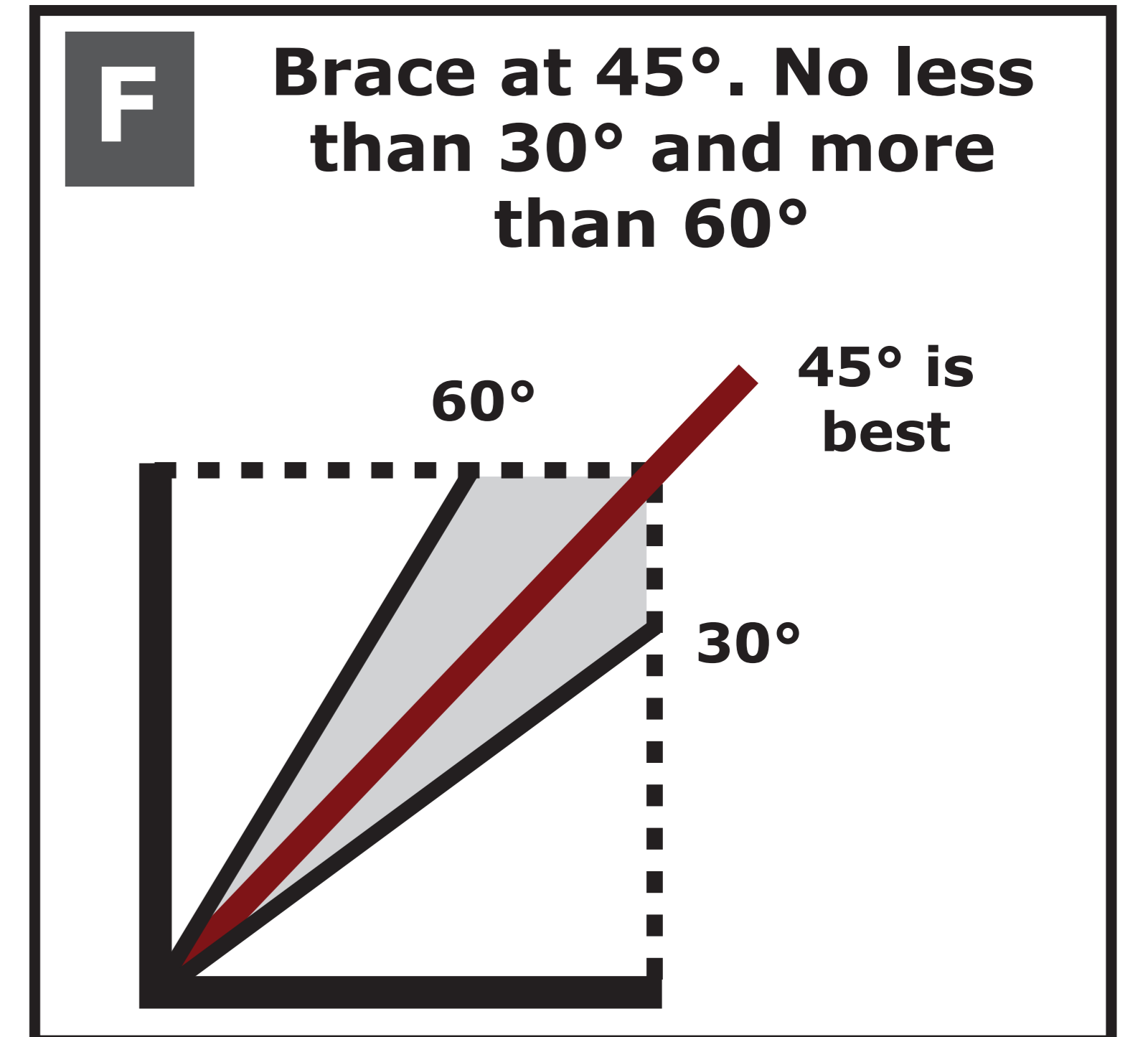

WHAT CAN I USE TO BRACE MY HOUSE?

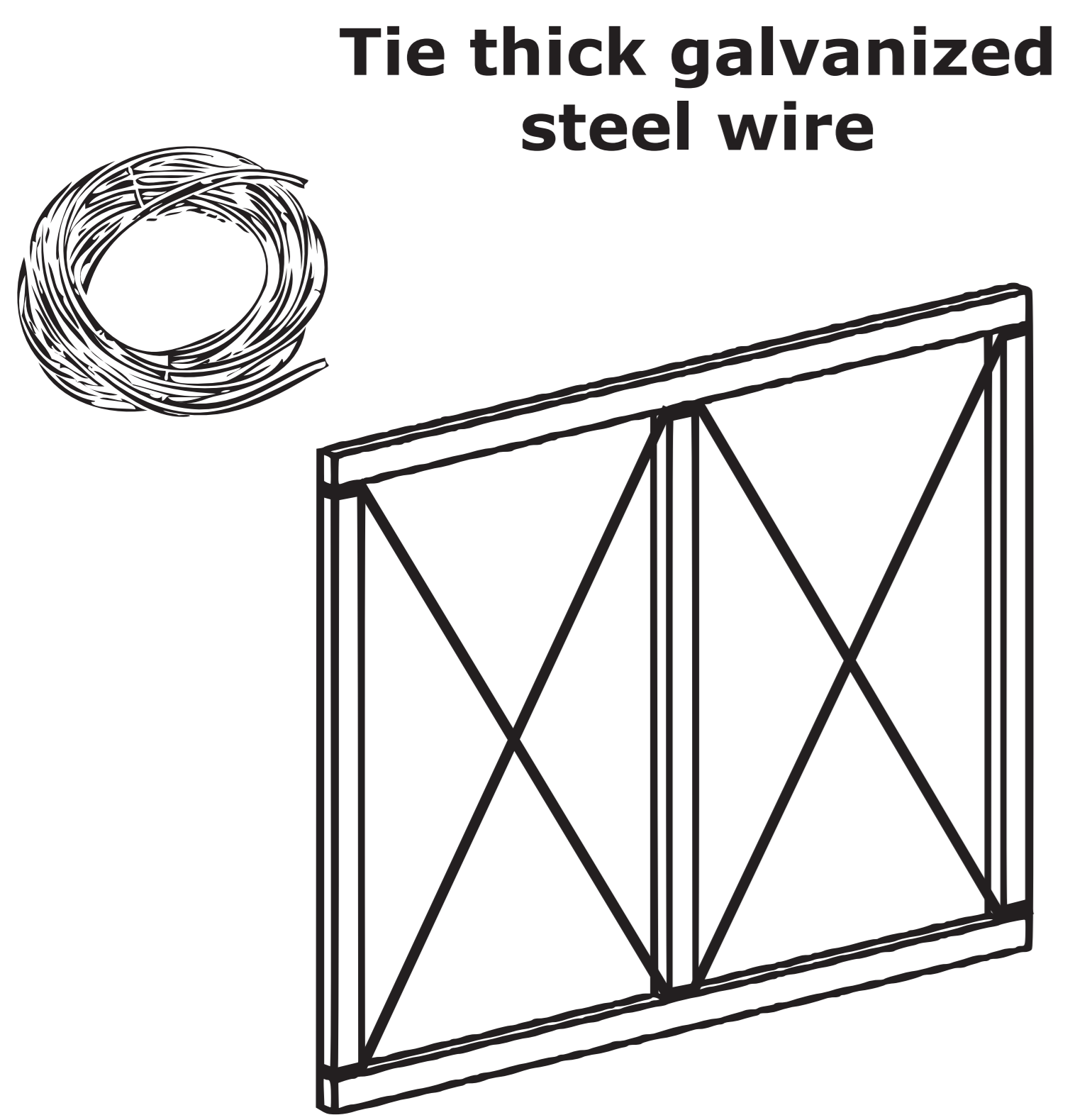

Strong ✓

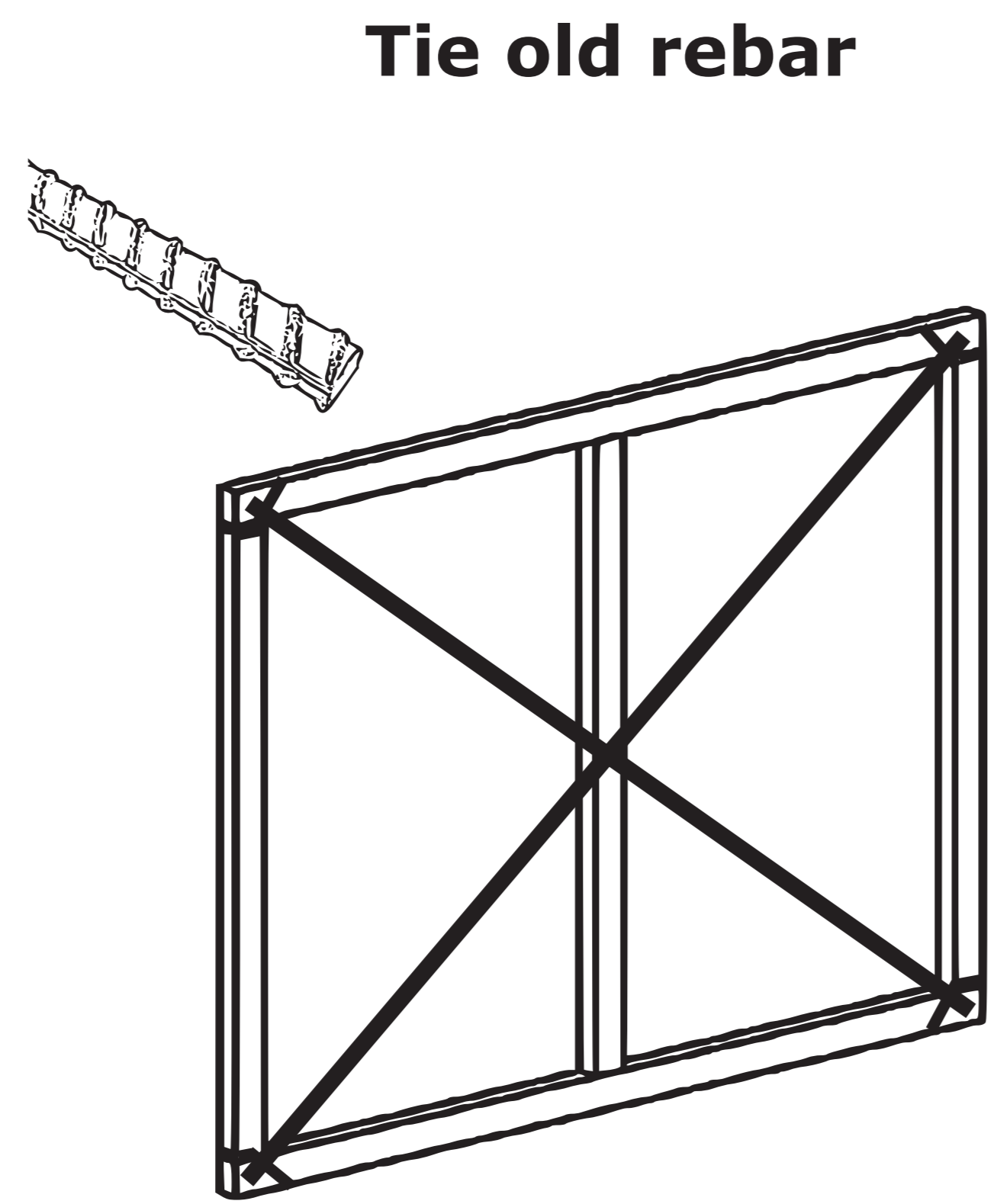

Stronger ✓

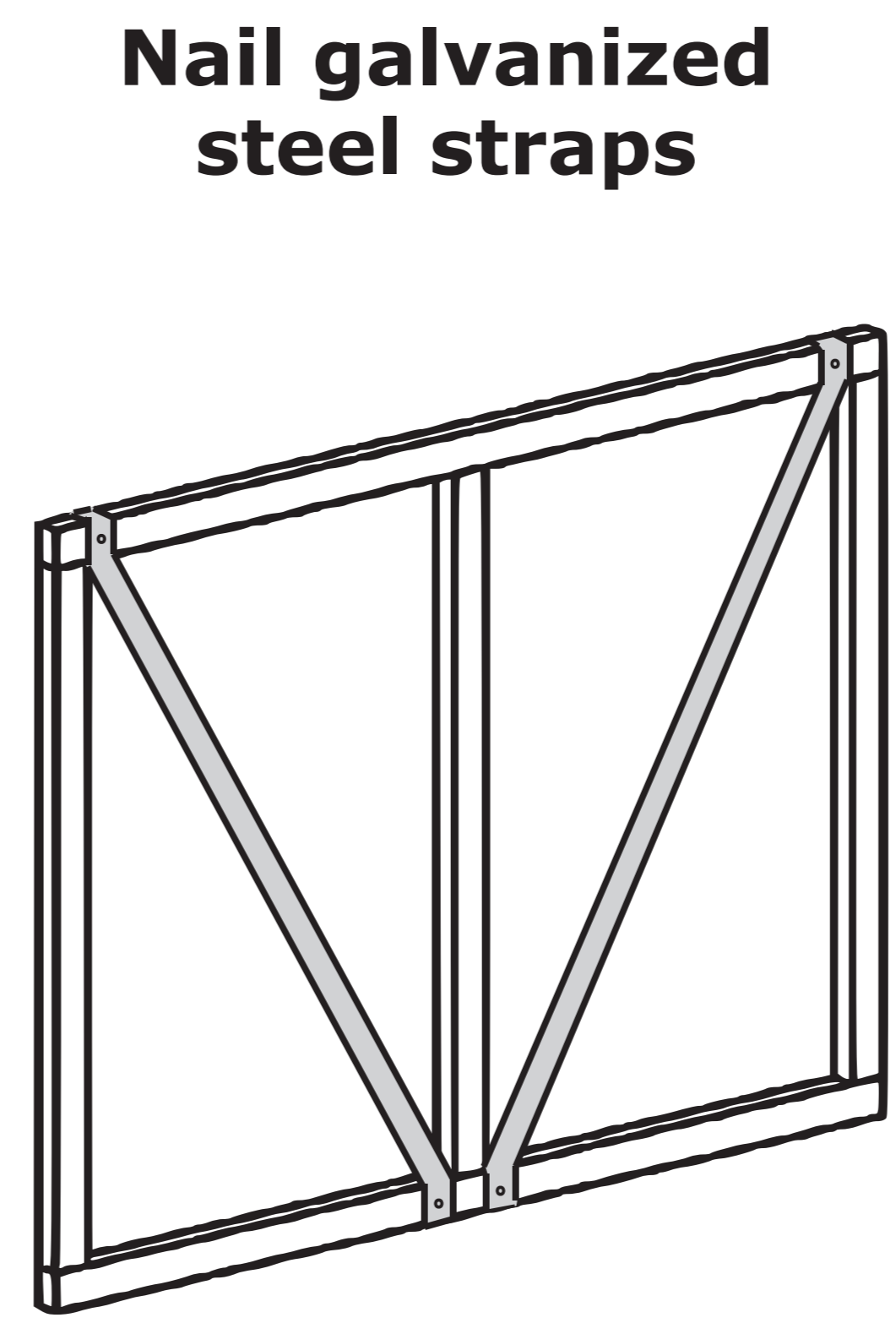
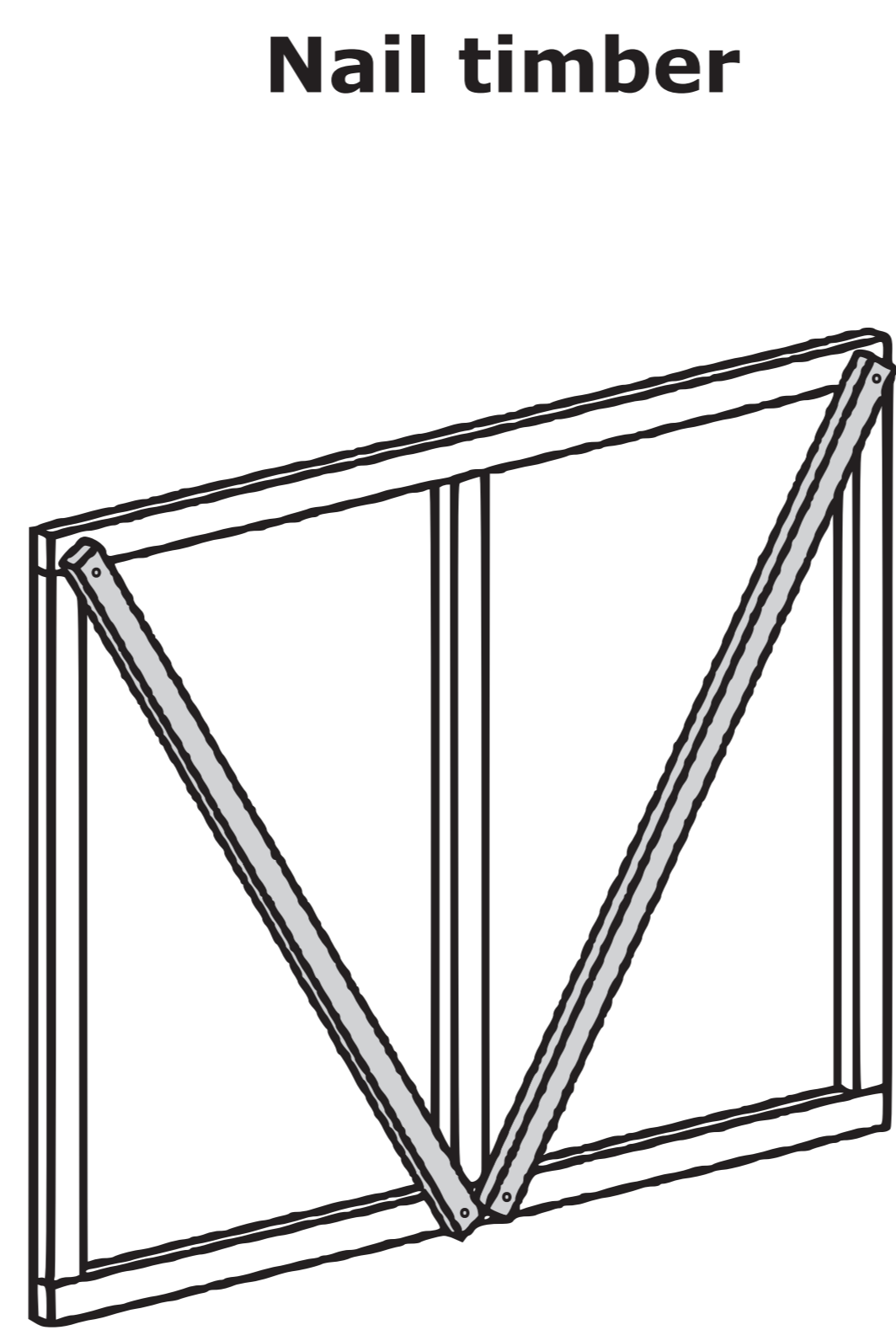

Strongest ✓✓



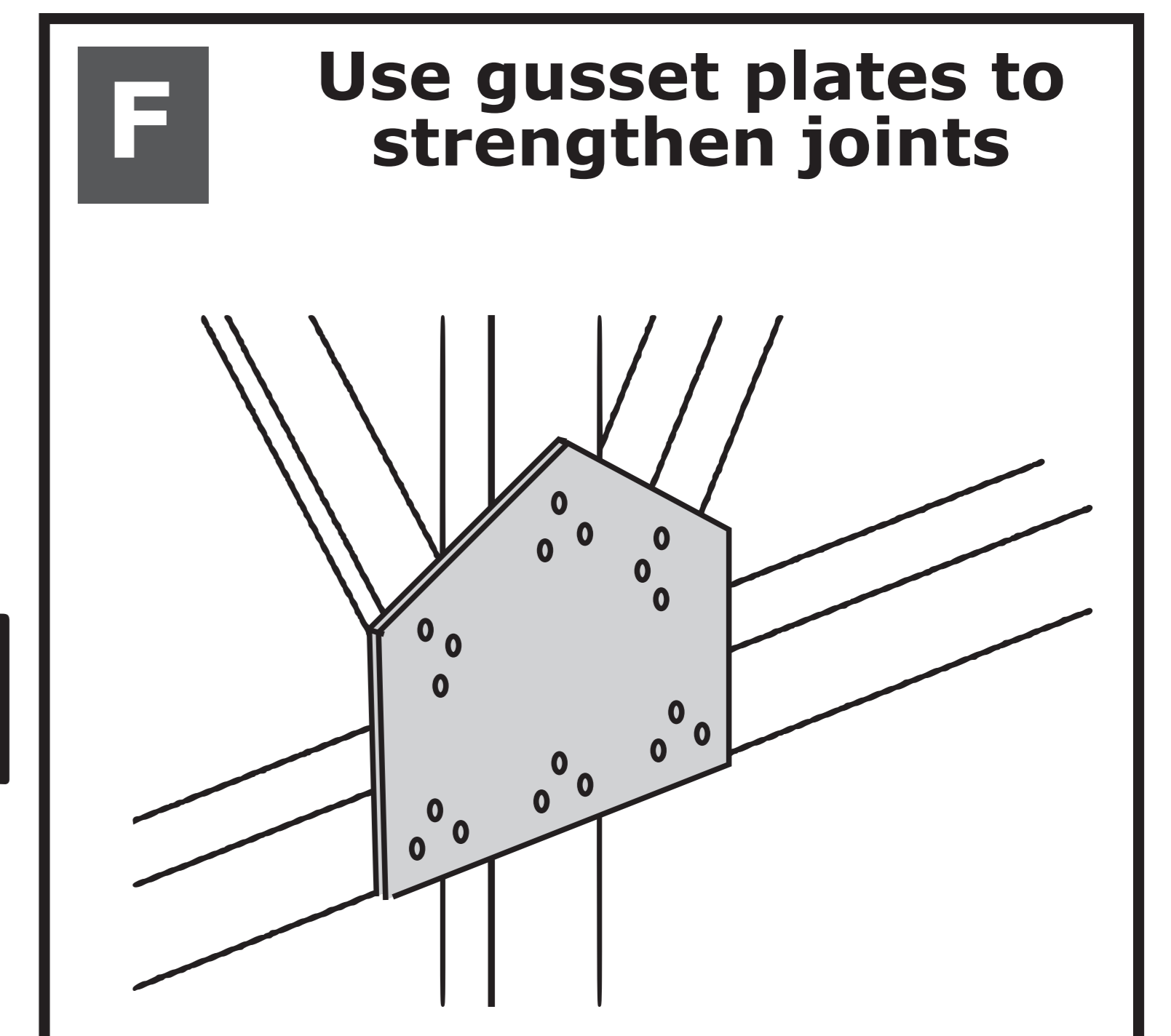
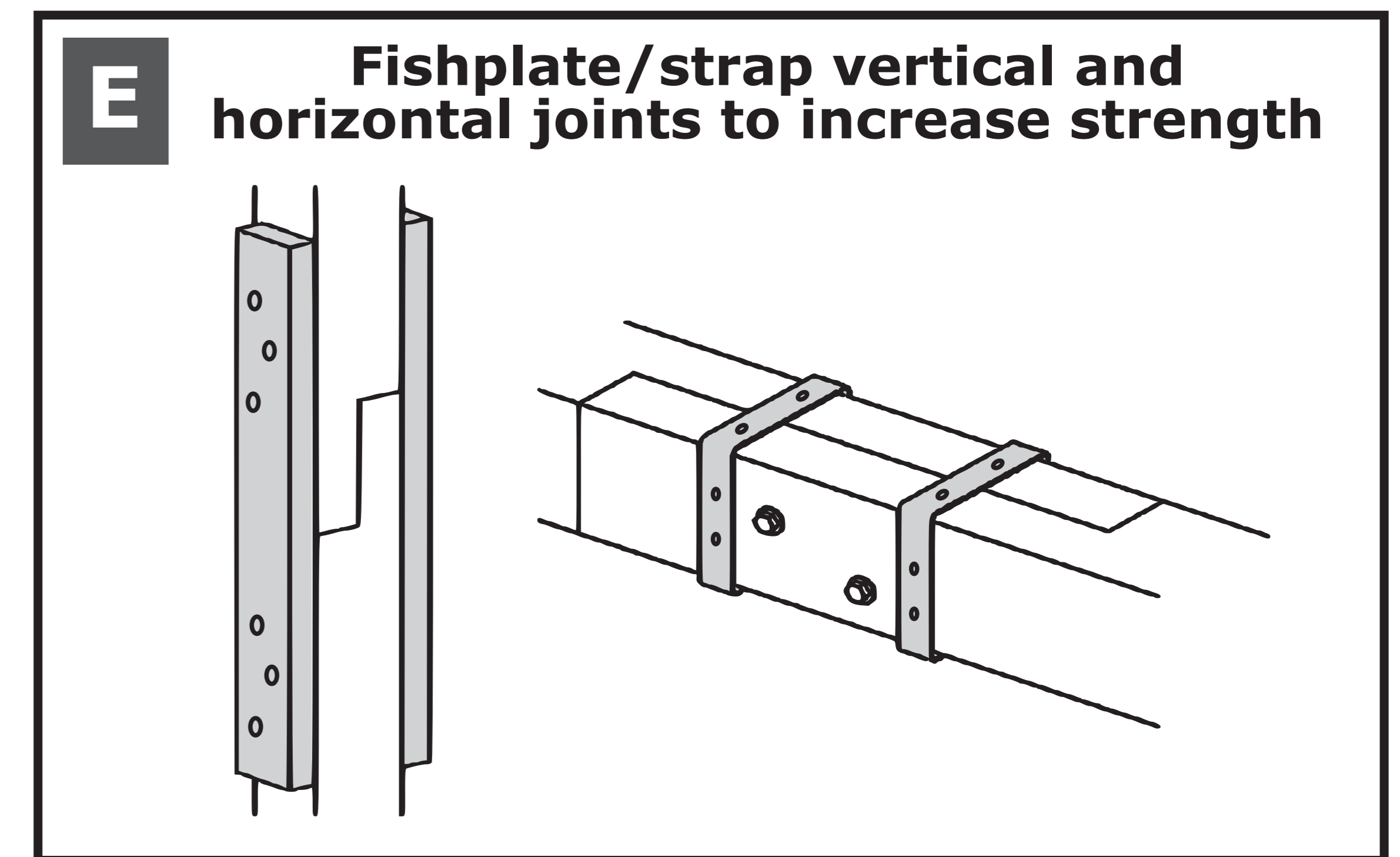
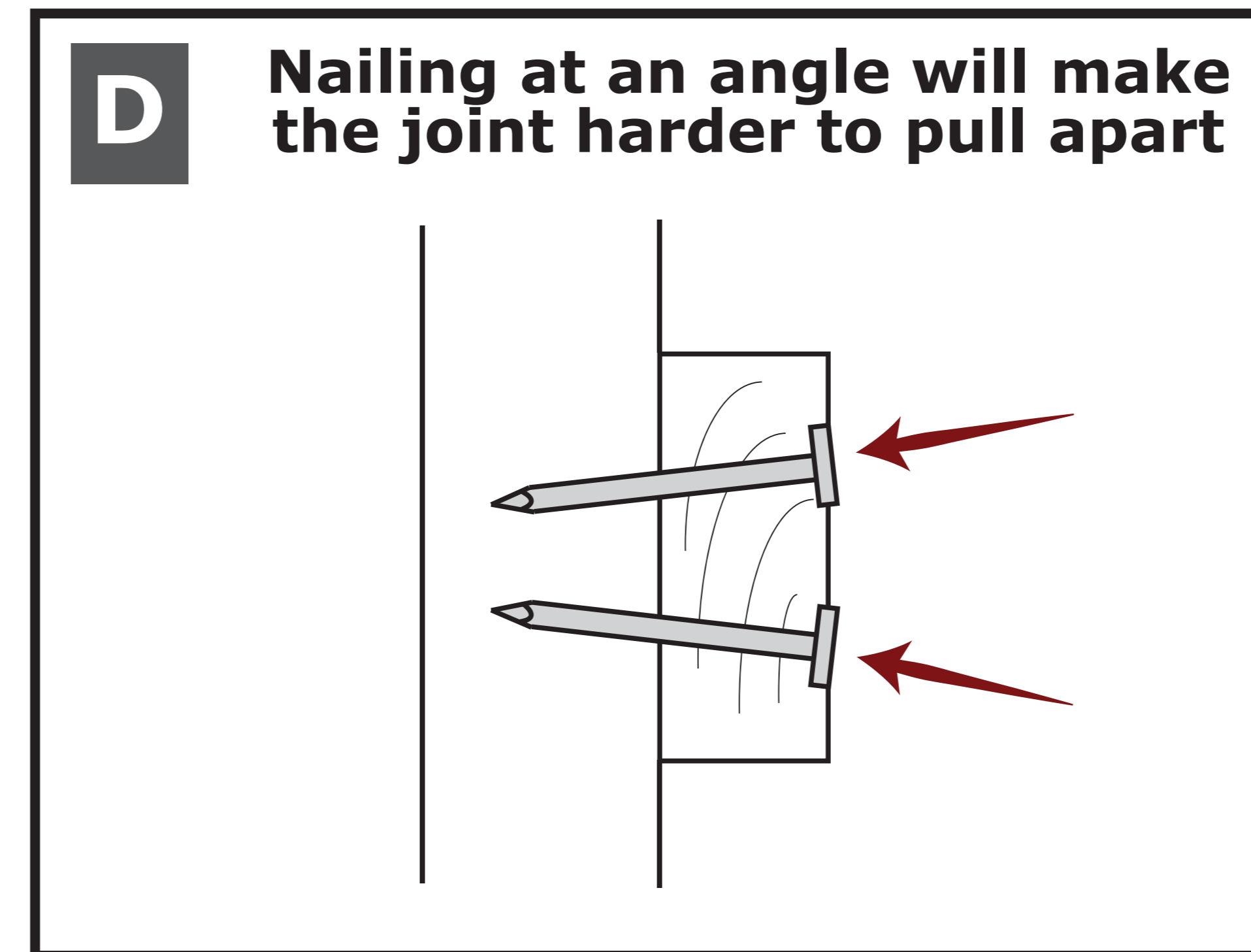
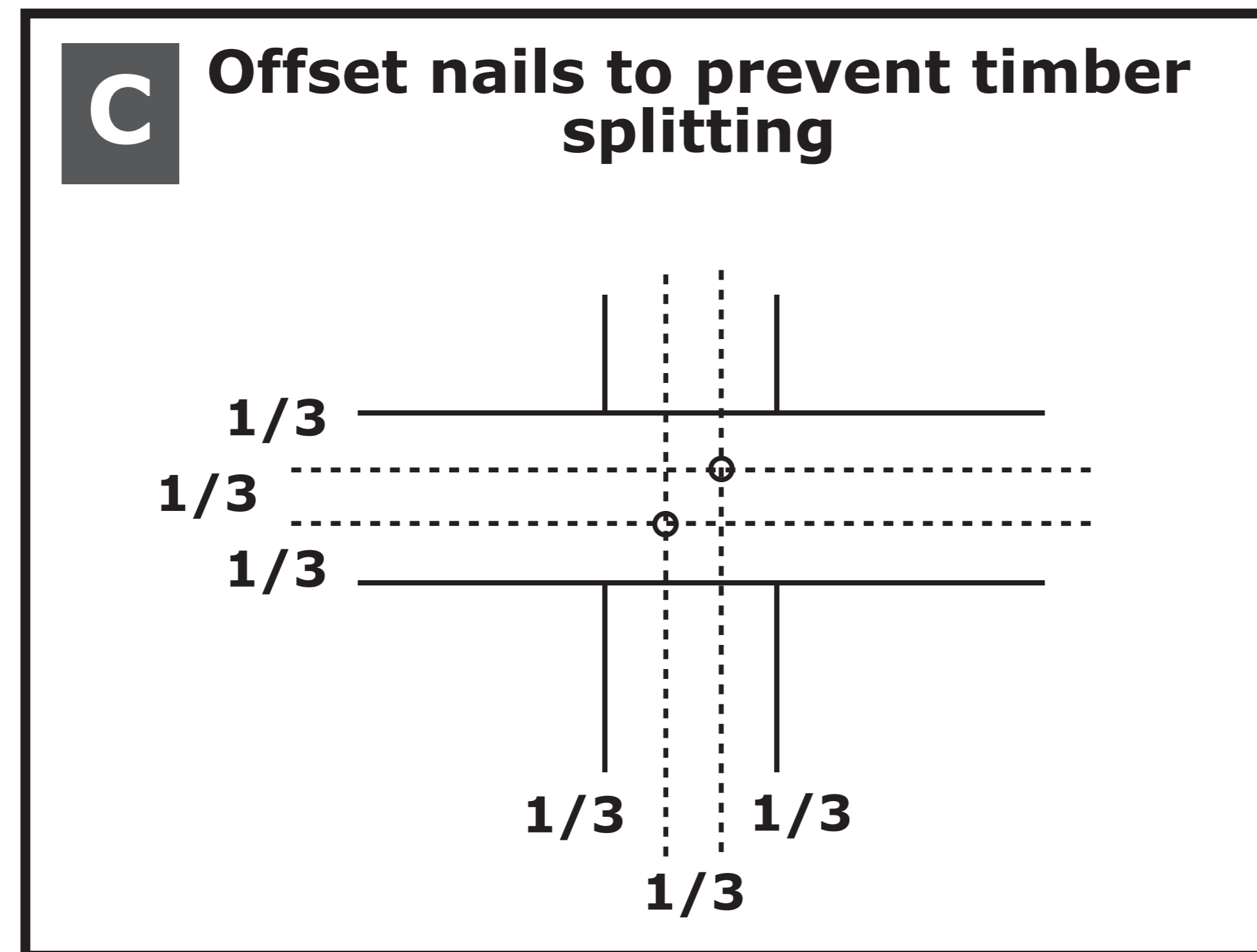
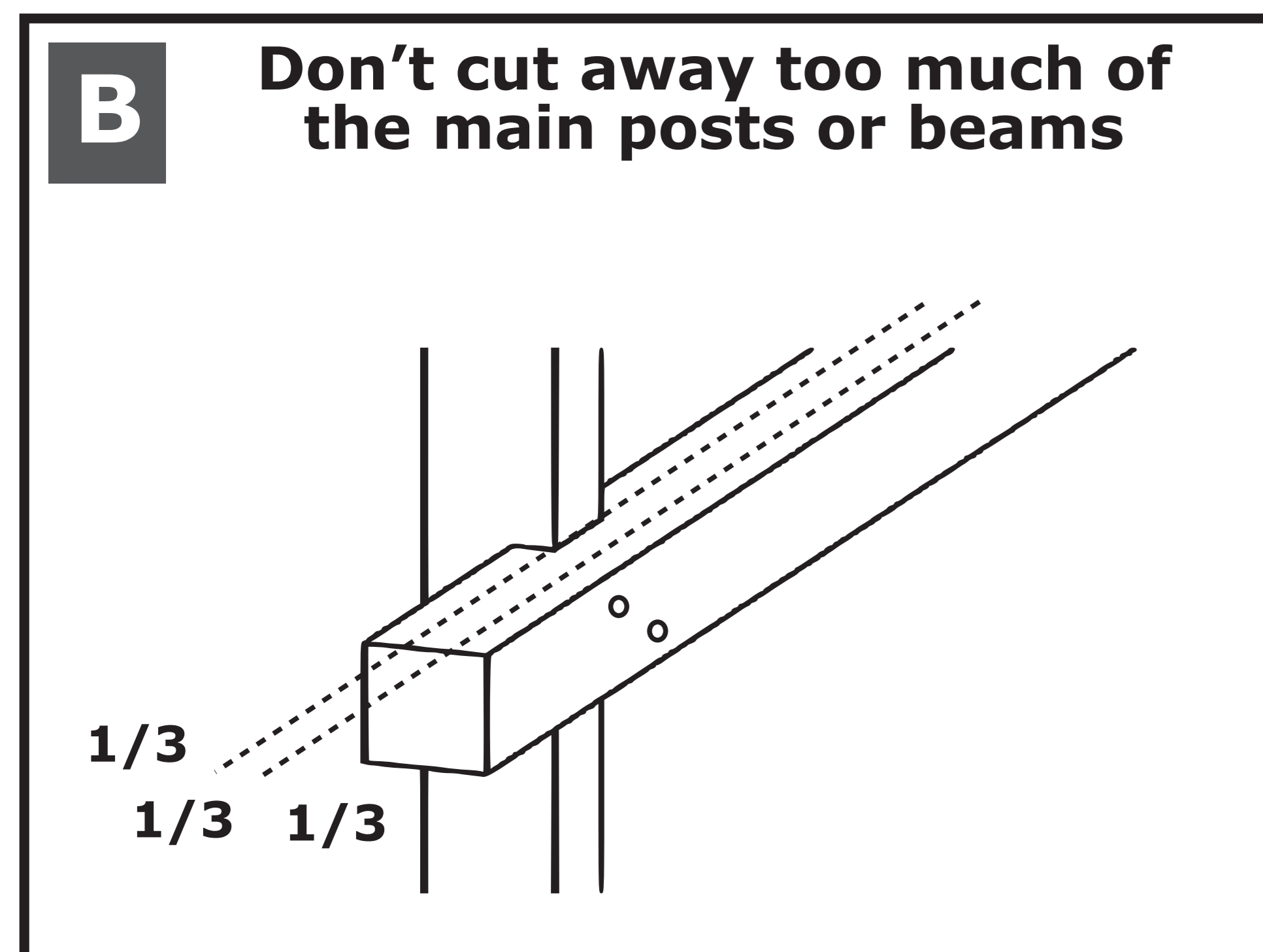
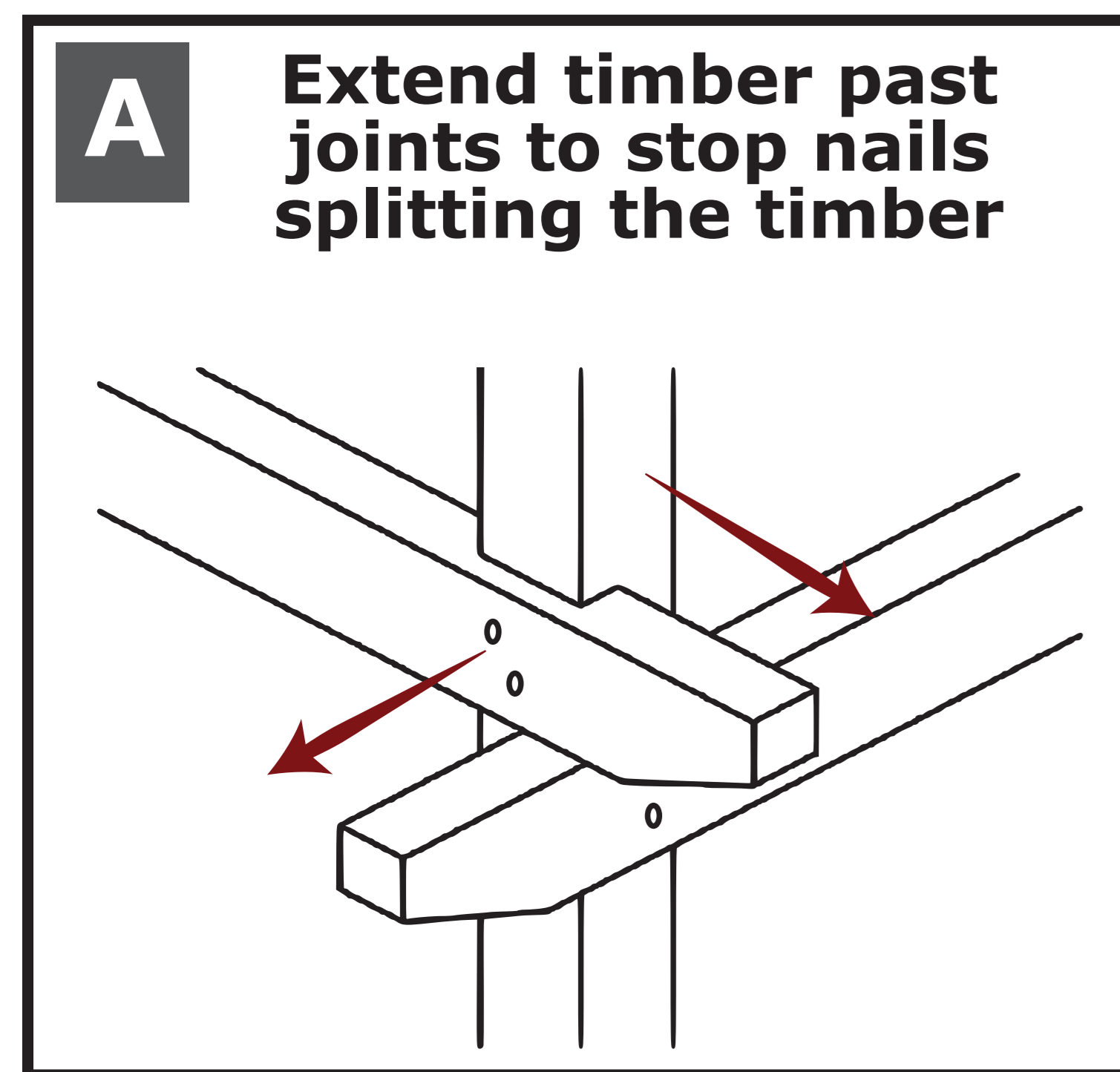

Use strong joints ✓

Your house is only as strong as the weakest joint. Build every joint so it can't be pushed or pulled apart. Horizontal nails are better as they can't be pulled apart by the wind sucking your house up or pulling it down.

WHAT CAN I USE TO STRENGTHEN JOINTS?

<p>Single nail</p> <p>Too Weak ✗</p>	<p>Nails</p> <p>Strong ✓</p>	<p>Screw</p> <p>Stronger ✓</p>	<p>Interlock joint and nail</p>	<p>Fishplate or cleats</p> <p>Strongest ✓✓</p>
--	--	--	--	--

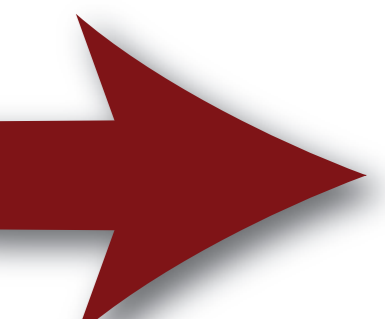

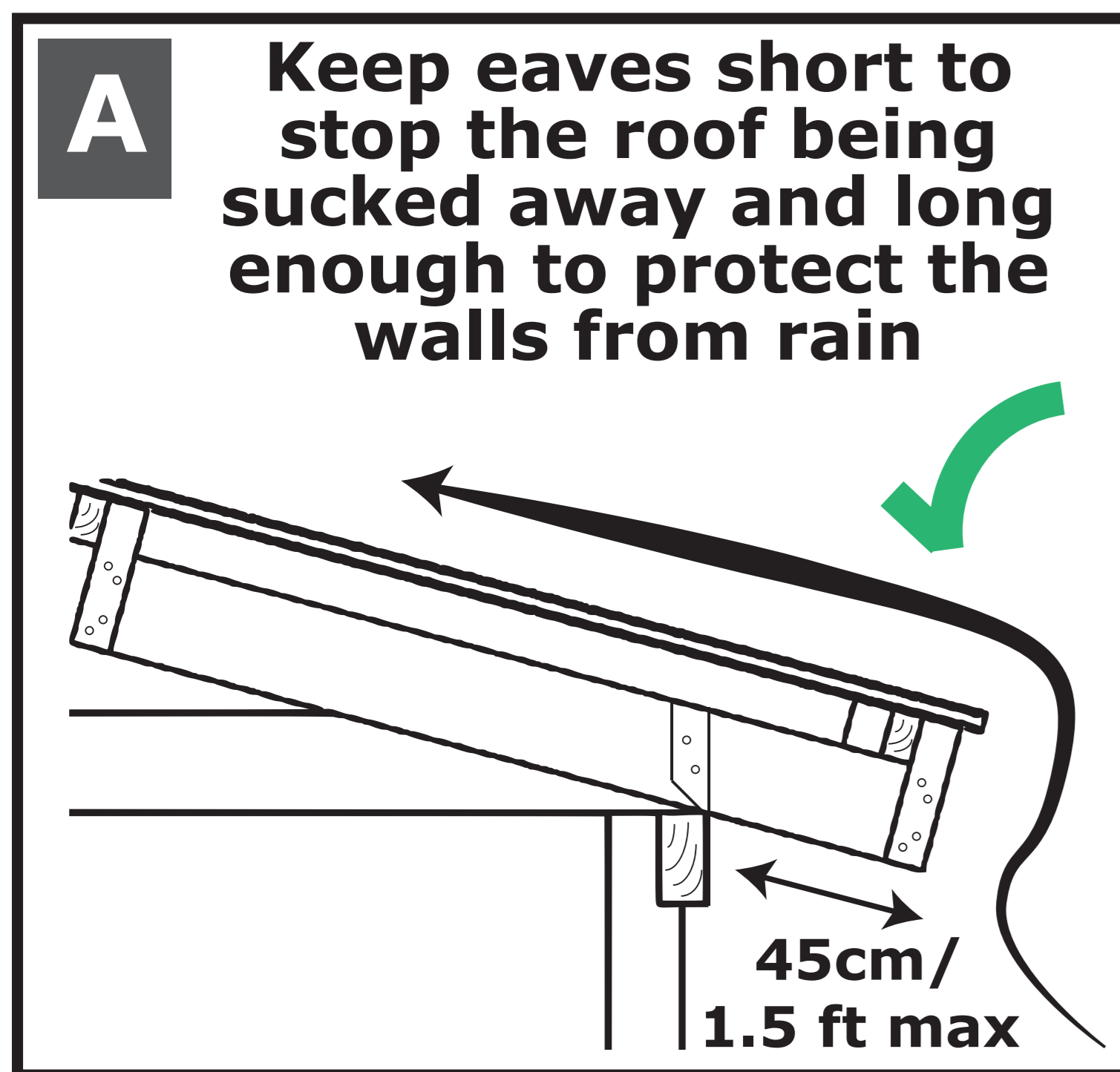

A good house needs a good roof

The way you design and build your roof is critical to protect you against strong winds and rain. Build your roof the right shape and pitch, and well nail down to protect against a storm.

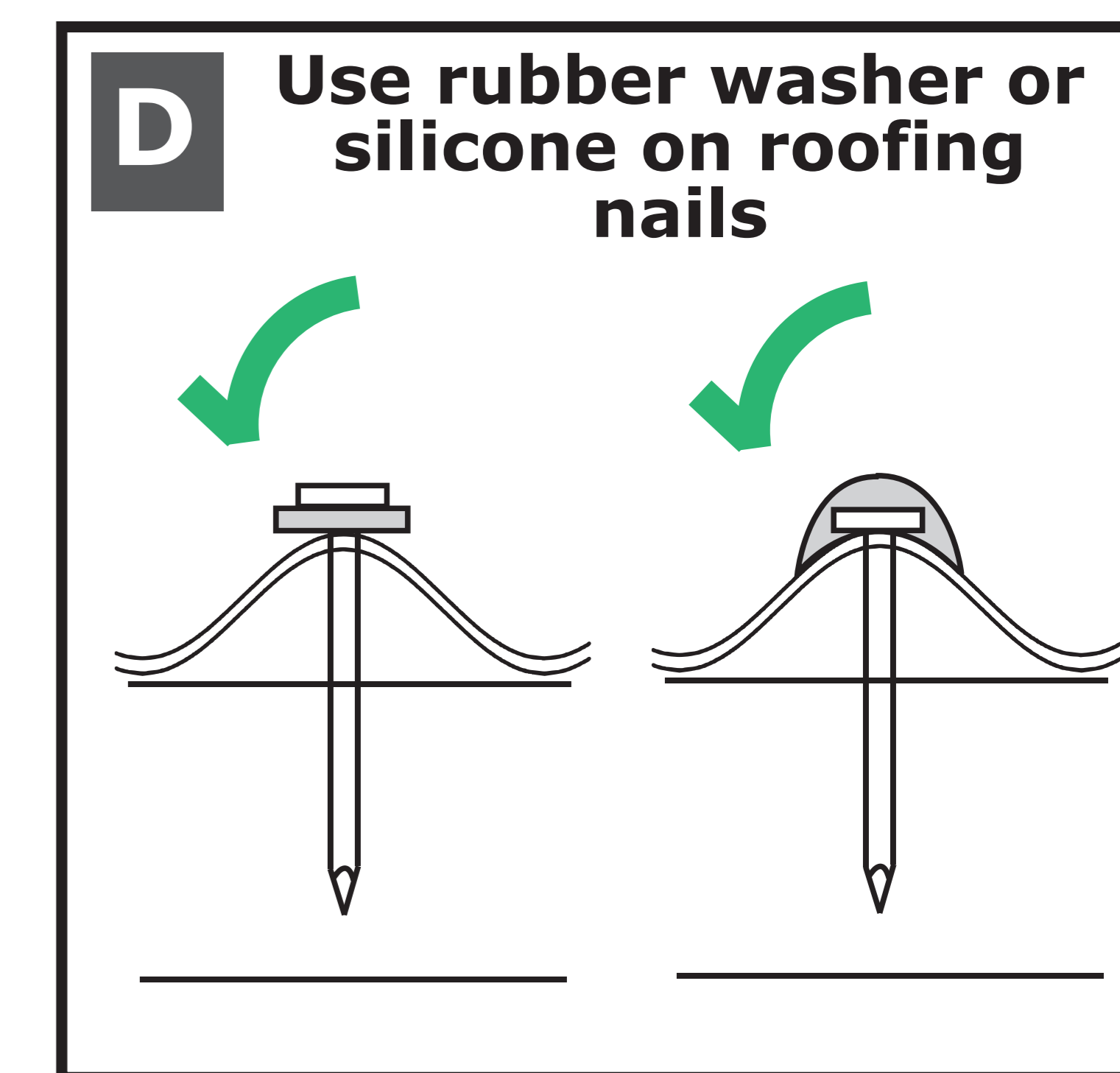
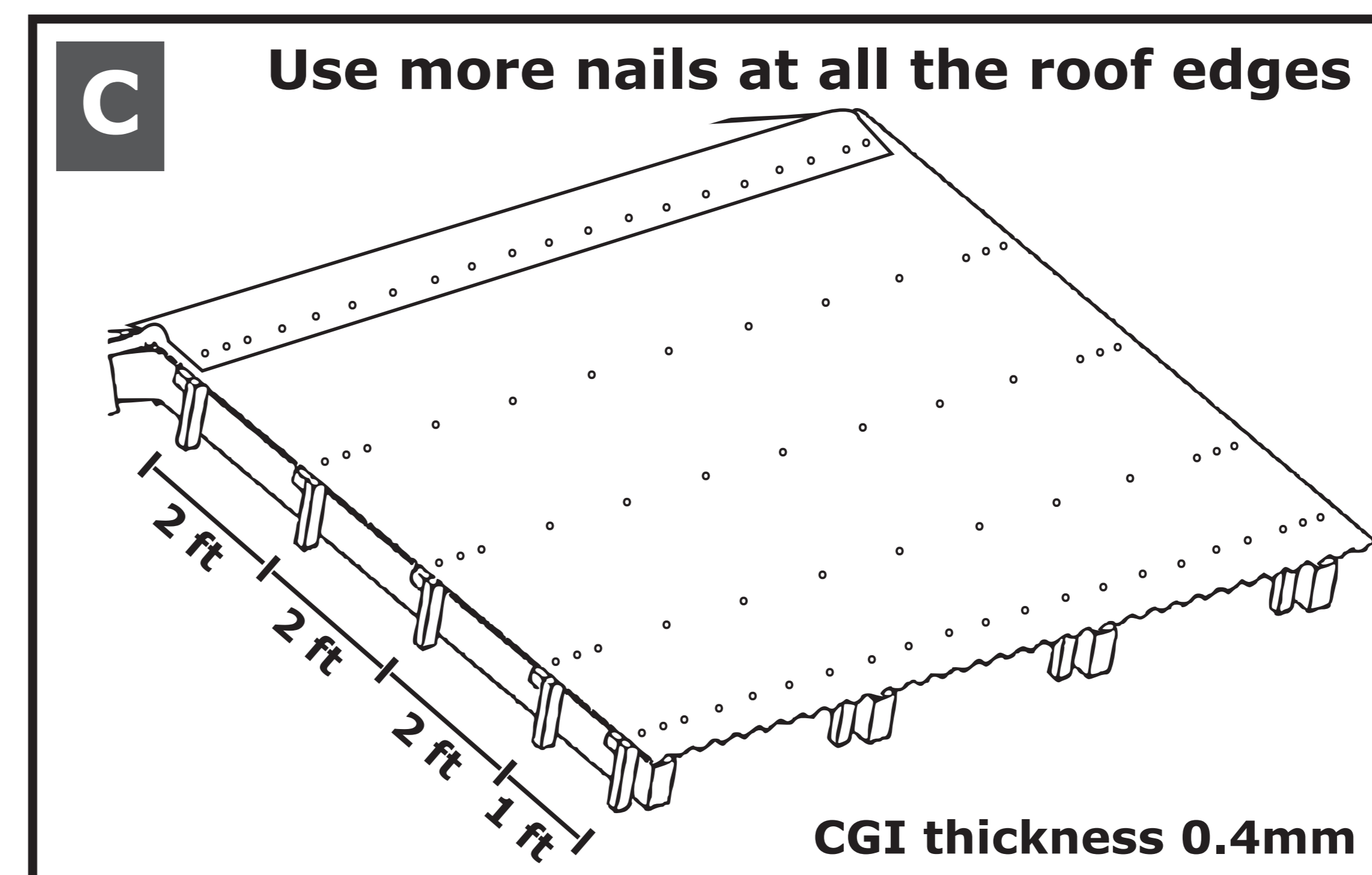
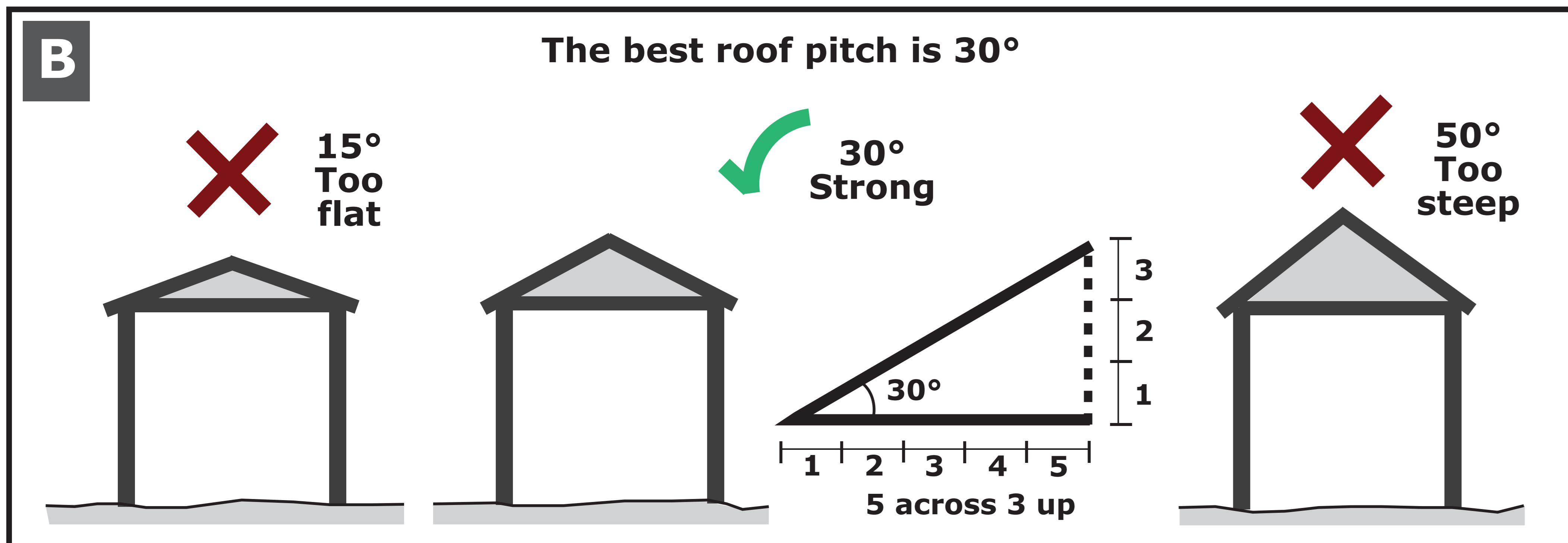
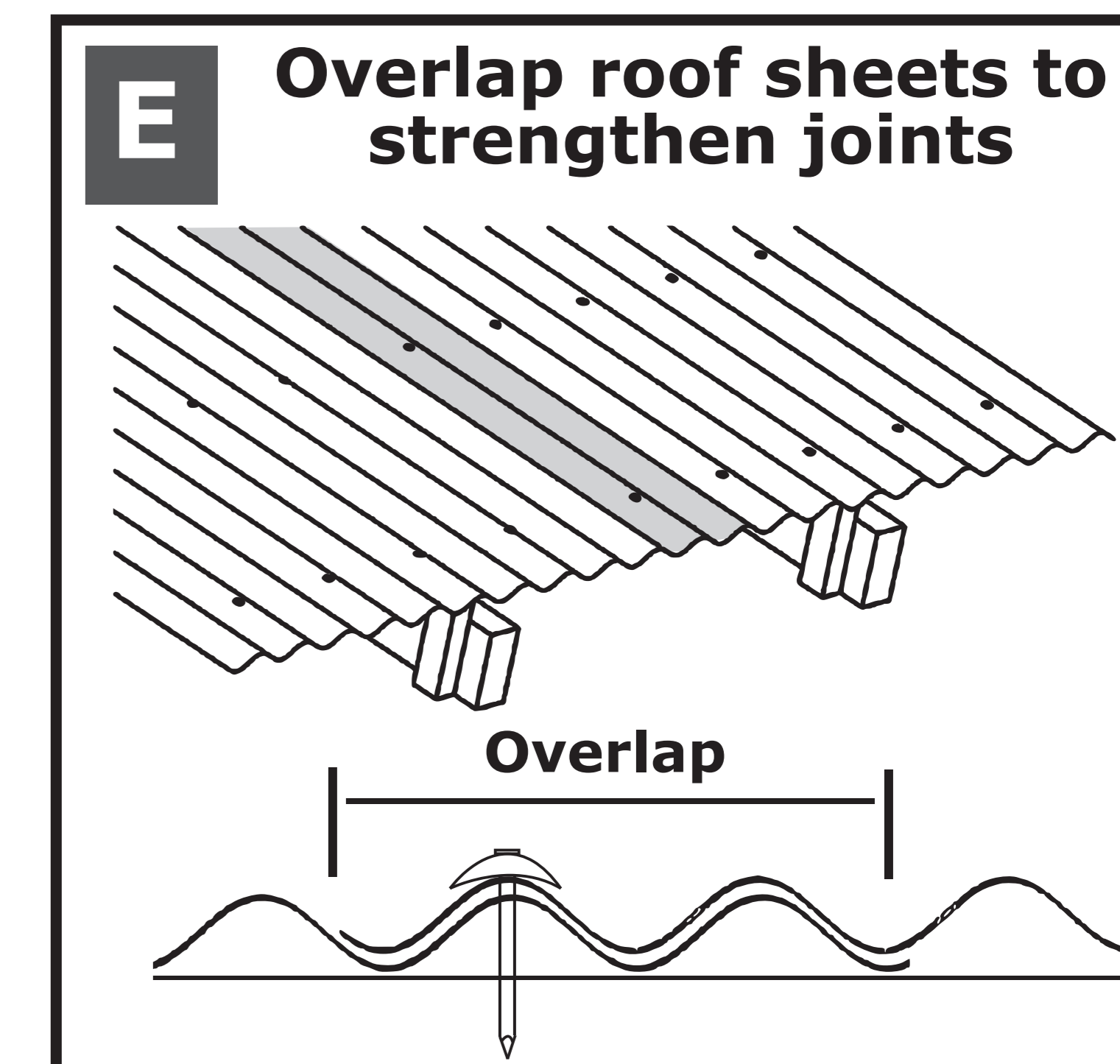

WHAT CAN I USE TO SECURE MY ROOF?

WHAT ROOF SHAPE SHOULD I USE?

<p>Regular nail</p> <p>Too Weak X</p>	<p>Umbrella head nail and washer</p> <p>Strong ✓</p>	<p>German wire (good for bamboo)</p> <p>Strongest ✓✓</p>	<p>Twisted umbrella head nail and washer</p> <p>Strongest ✓✓</p>	<p>Roofing screw and washer</p> <p>Strongest ✓✓</p>
--	---	---	---	--

<p>Single slope roof</p> <p>Too Weak X</p>	<p>Two sided gable roof</p> <p>Strong ✓</p>	<p>Multiple roof slopes reduce the risks of your roof being pulled apart</p> <p>Strongest ✓✓</p>
---	--	---

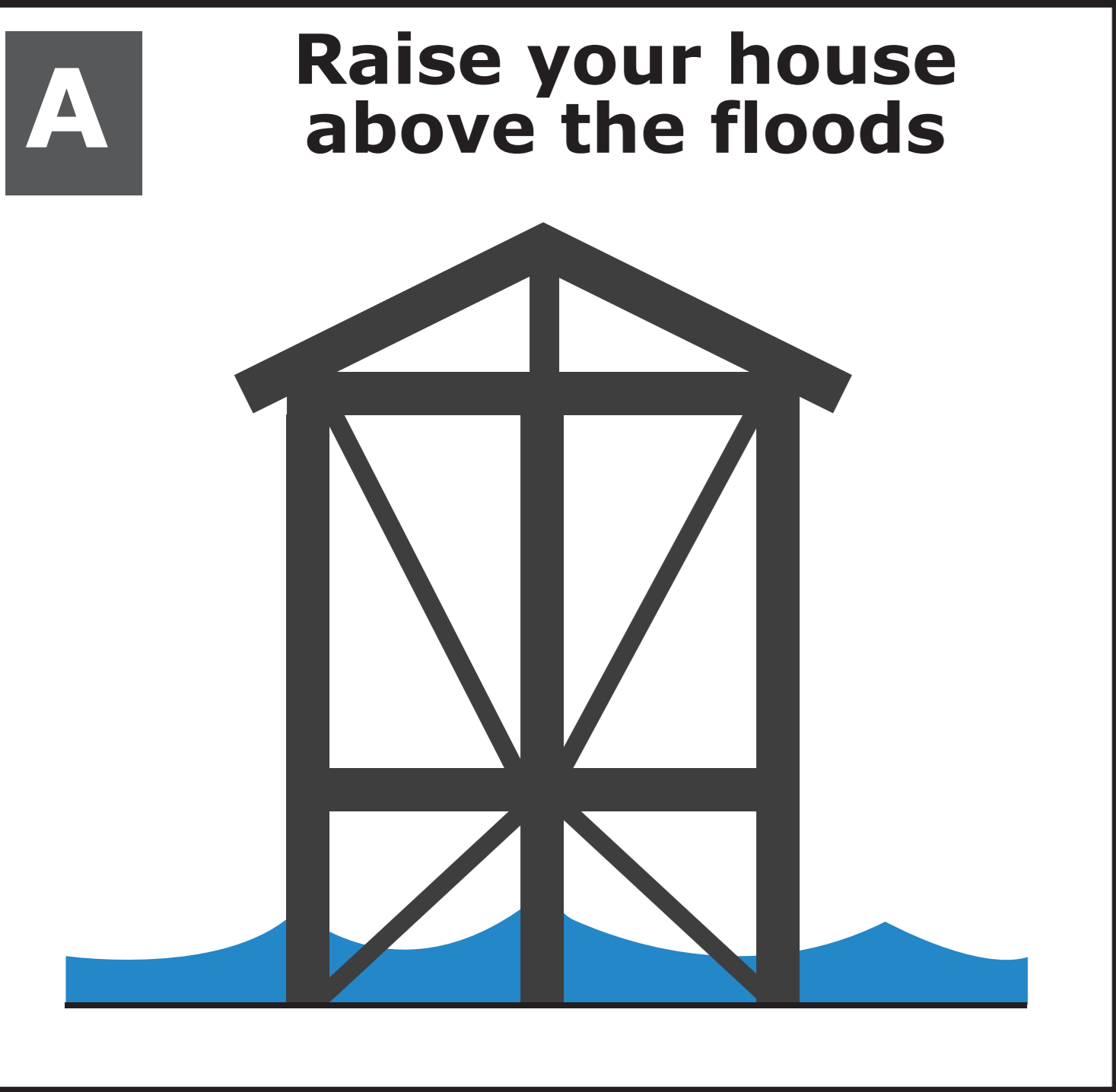

Site you house safely ✓

Identify the hazards in your location and build as well as you can to resist them.

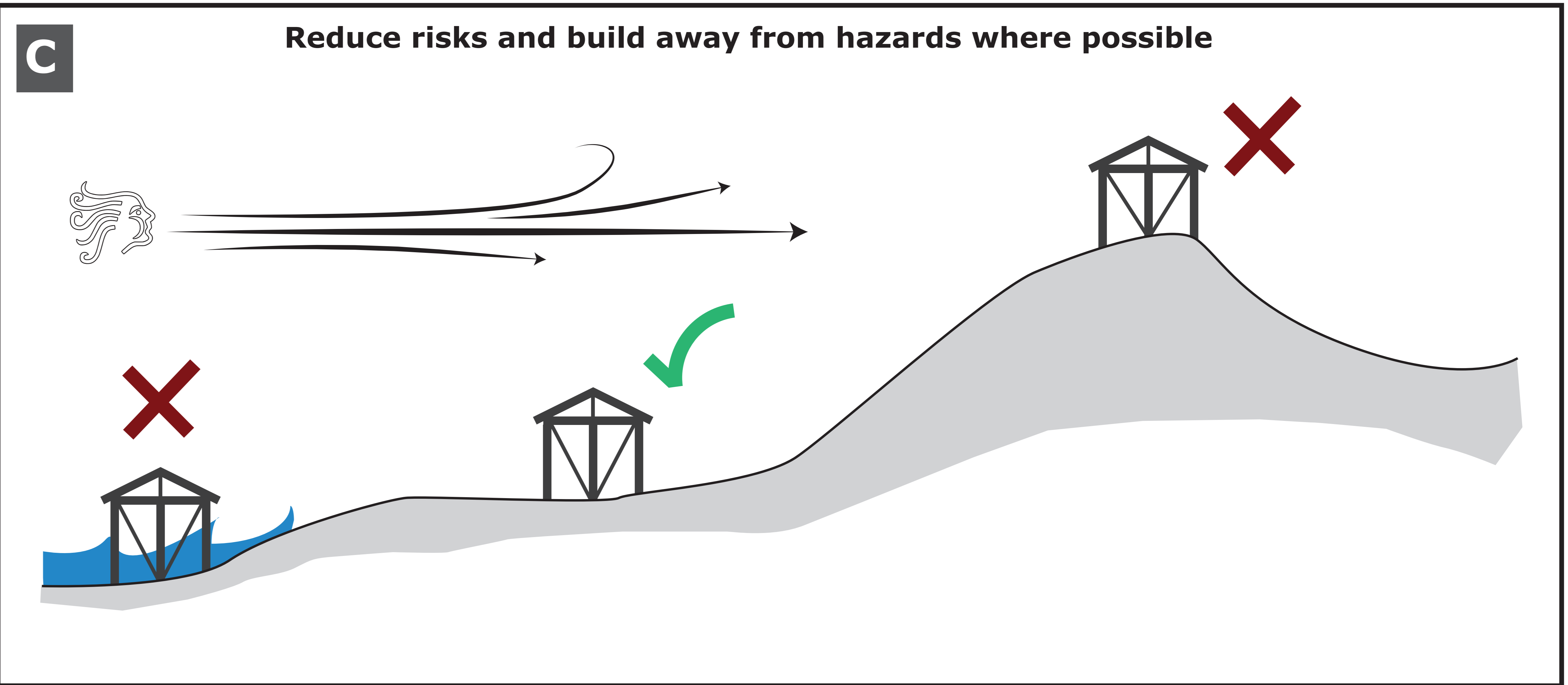
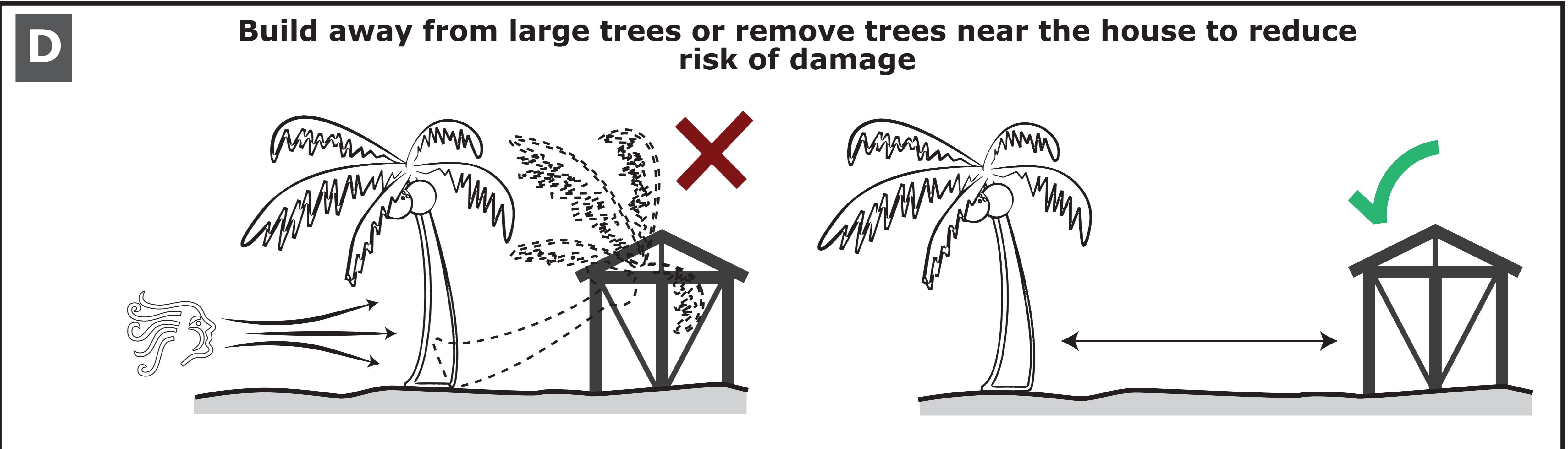
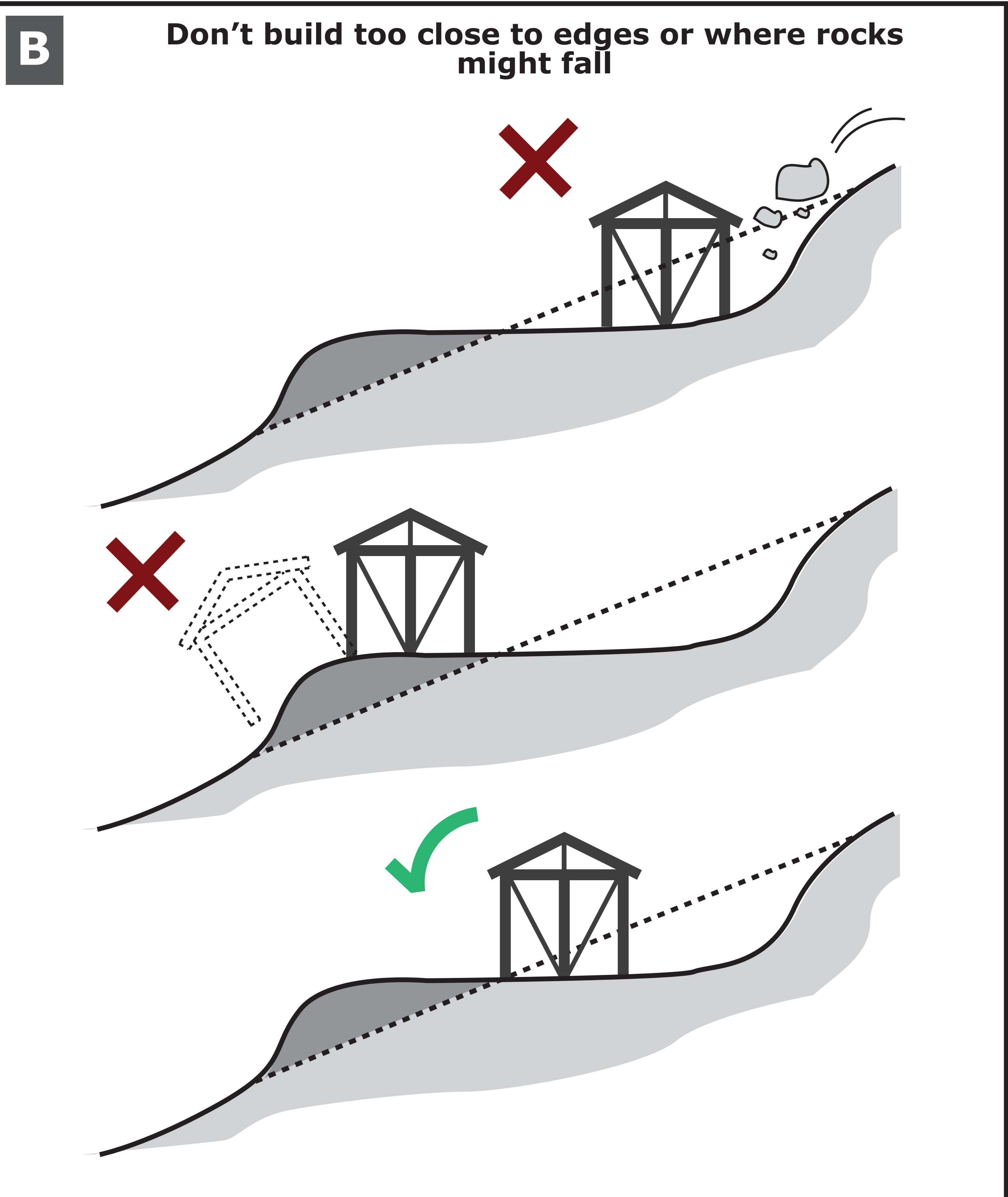

A Overhangs weaken the strength of your house



A simple shape will keep you safe

The shape of your house is important to reduce damage in strong winds. Always keep the design simple and strong.

B Simple, compact shapes are the safest

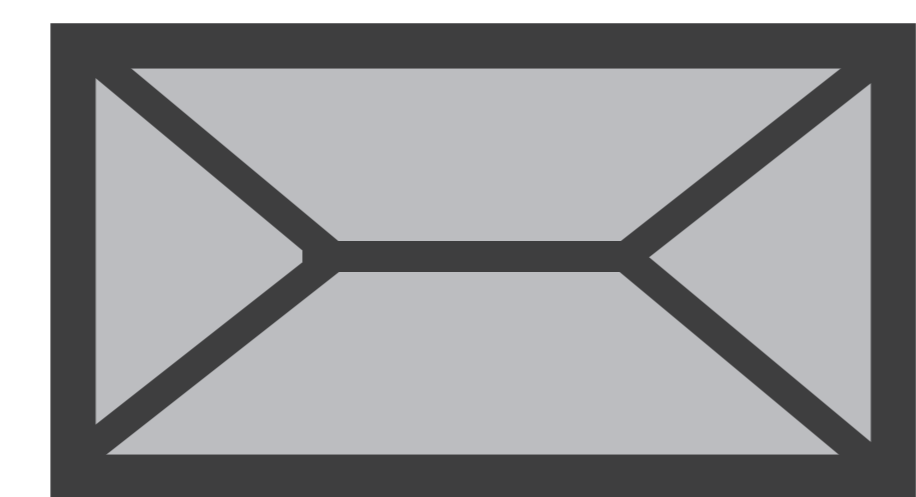
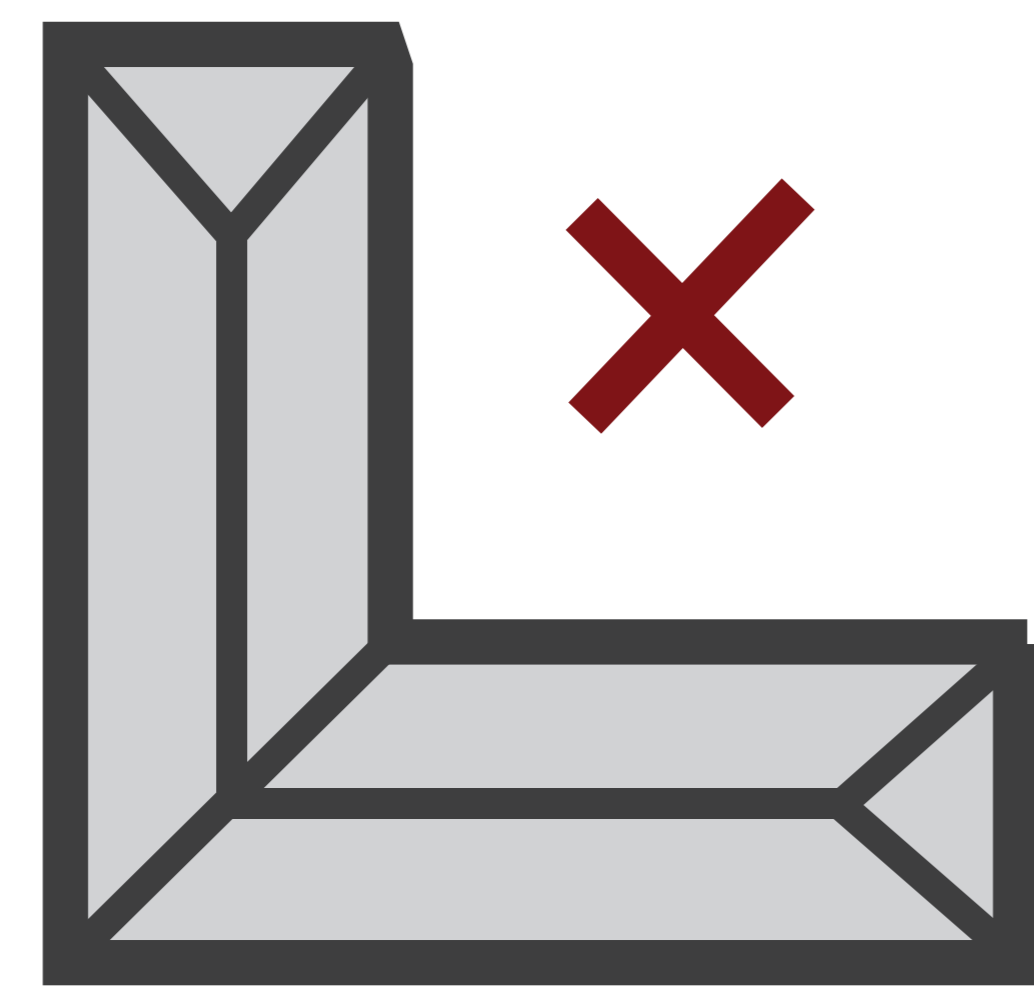

Length no more than three times the width

C Don't extend too long

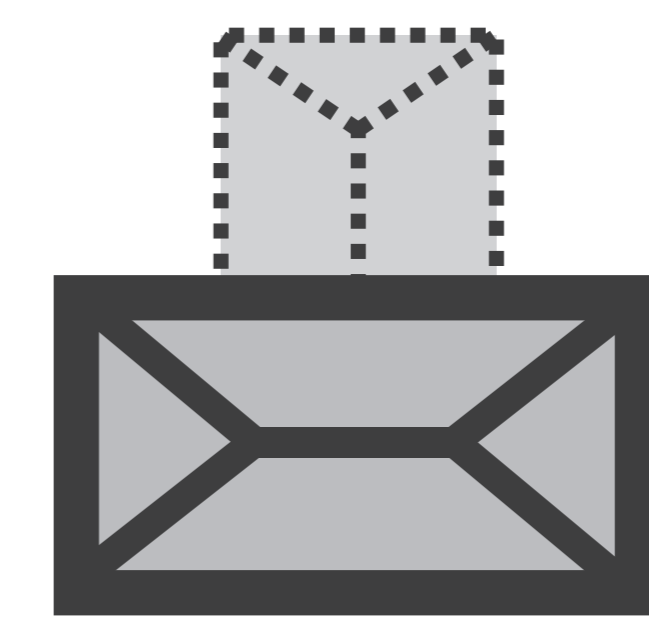
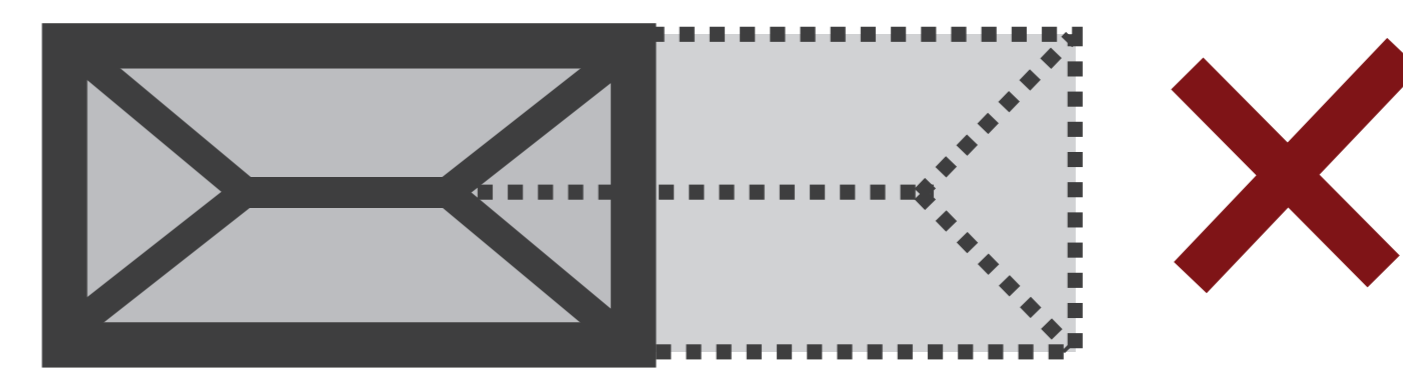

D Lean to roofs separate to main roof

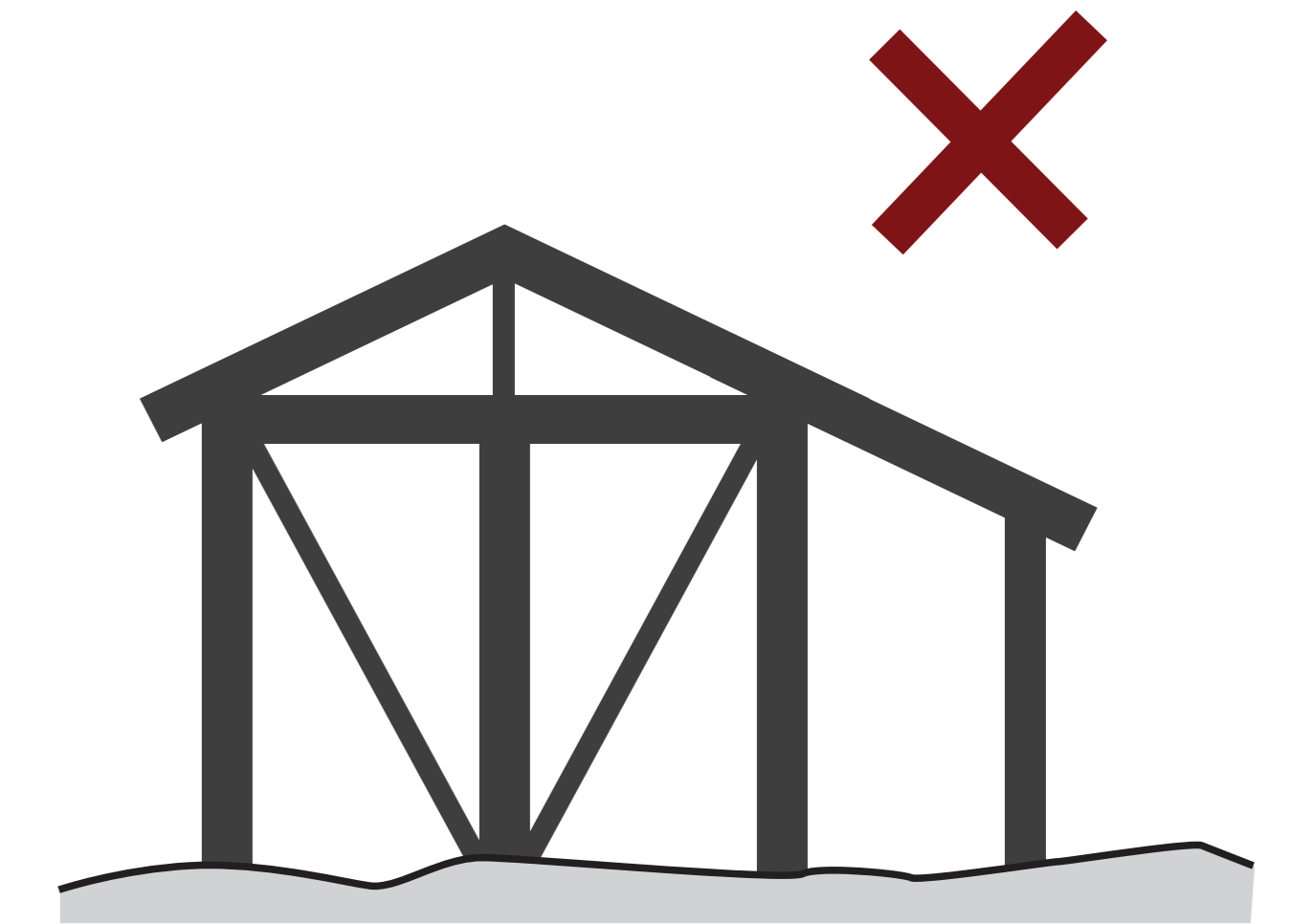

HOW SHOULD WE PLAN A GROUP OF BUILDINGS?

Houses too close together trap the wind

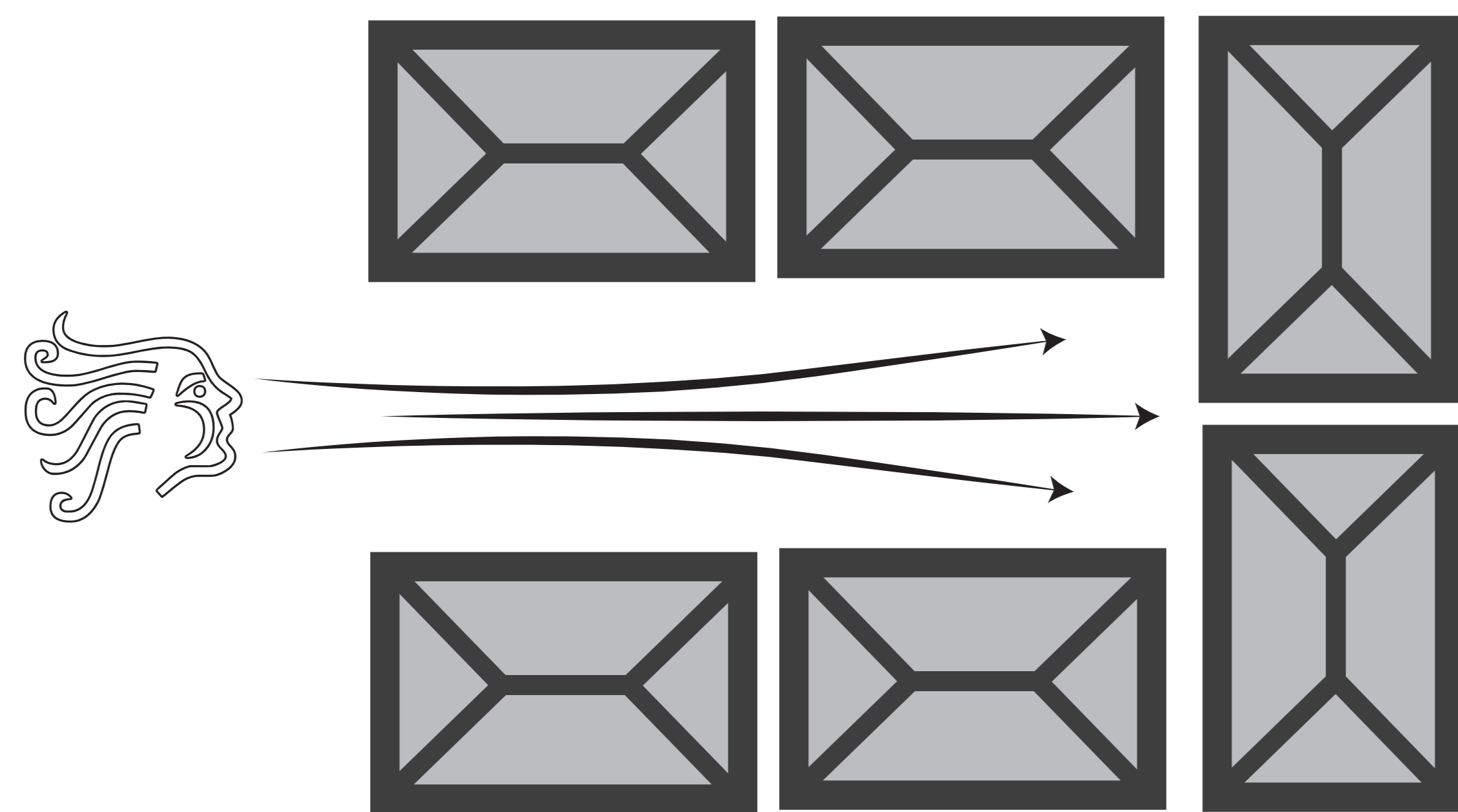

Spacing houses to let the wind pass

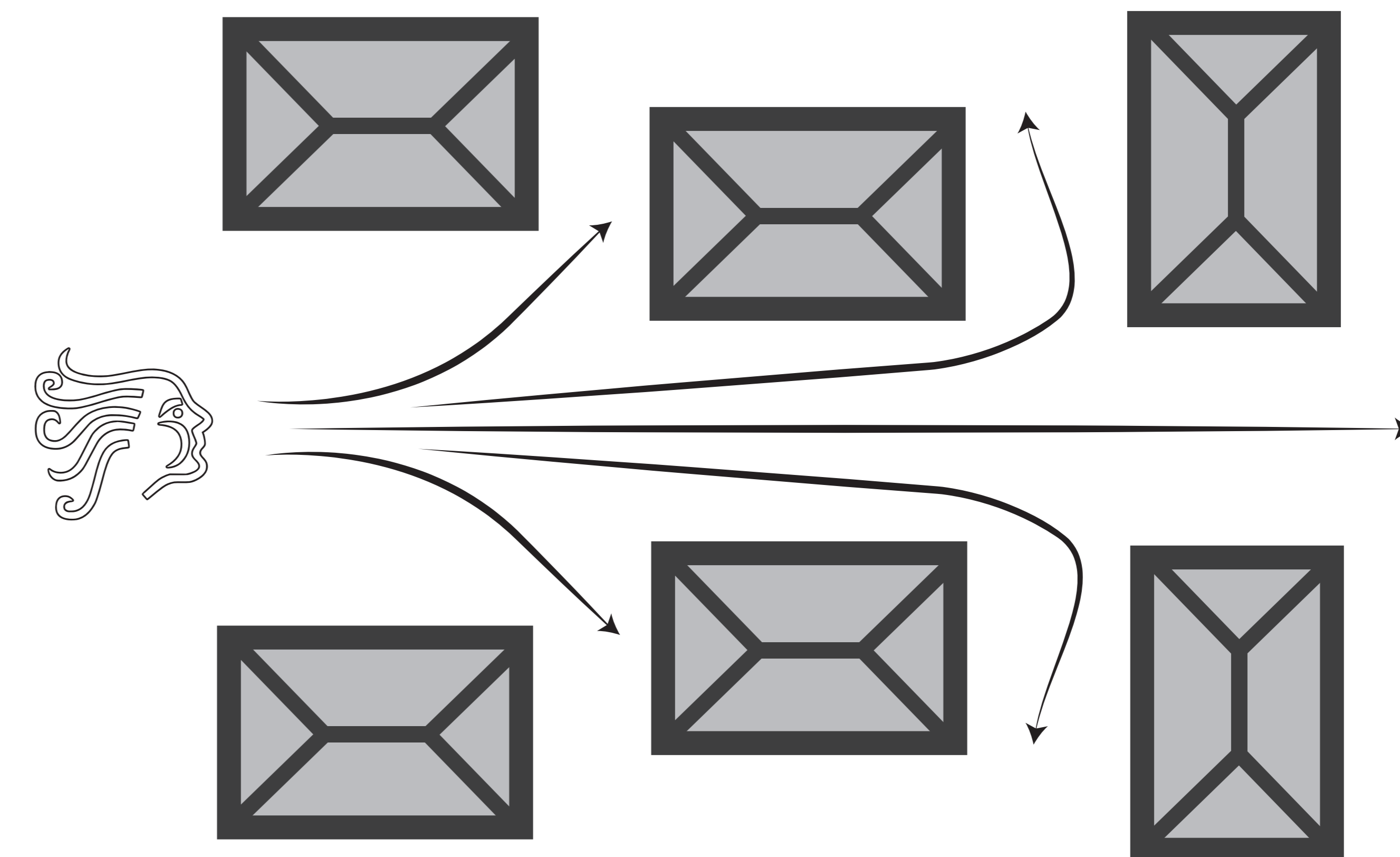



HOW CAN I PREPARE MYSELF AND COMMUNITY FOR A DISASTER?

 **EVACUATION** ✓

- Make a plan and practice it
- Decide early if you will evacuate or stay in place
- Prepare safe evacuation route
- Know where the evacuation sites are
- Know what transport you can use

 **COMMUNICATION** ✓

- Know the disaster warnings signals
- Know how you can receive information about a disaster
- Inform your relatives and friends where you will evacuate to
- Know how you will communicate with relatives and friends after disaster
- Know how and who to inform of your situation after a disaster
- Know where to find information on missing persons

 **GRAB BAG** ✓

- Prepare a waterproof 'grab bag' prior to a disaster
- Make the 'grab bag' easy to carry and include:
 - medical kit
 - extra clothing and safe shoes
 - batteries
 - torch and matches
 - basic food
 - cooking equipment
 - basic tools
 - important personal records/ID
- Don't forget some water