

1

## FANORENANA AMIN'NY TANY MAFY

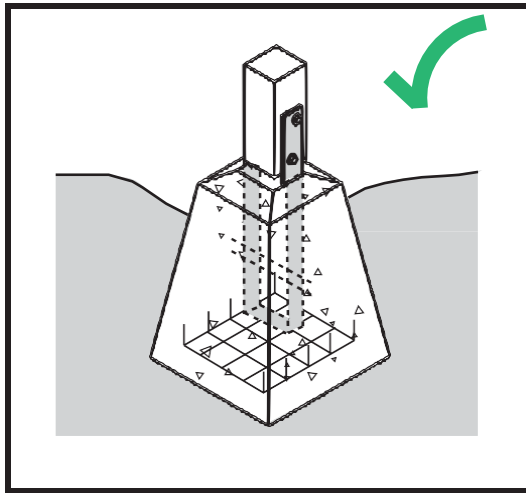

2

## FAMATORANA MIAINGA AVY AMBANY HATRANY AMBONY

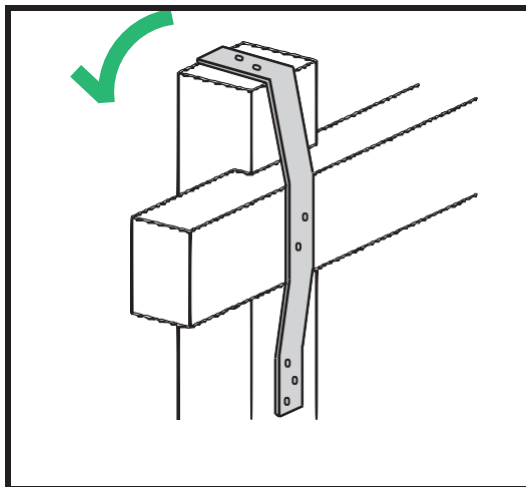

3

## FANOHANANA, FIAROVANA AMIN'NY RIVOTRA MAHERY

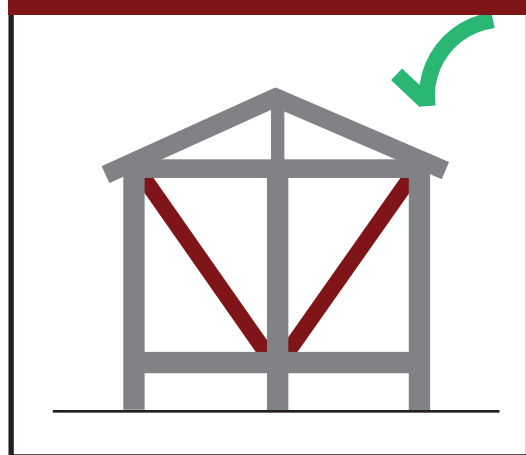

Nasehon'i GEZANI fa mila matanjaka kokoa ny fomba fanorenana trano. Ireto misy hafatra valo manan-danja momba ny fomba hanamboarana/hanamafisana ny trano sy hanorenana indray amin'ny fomba azo antoka kokoa.

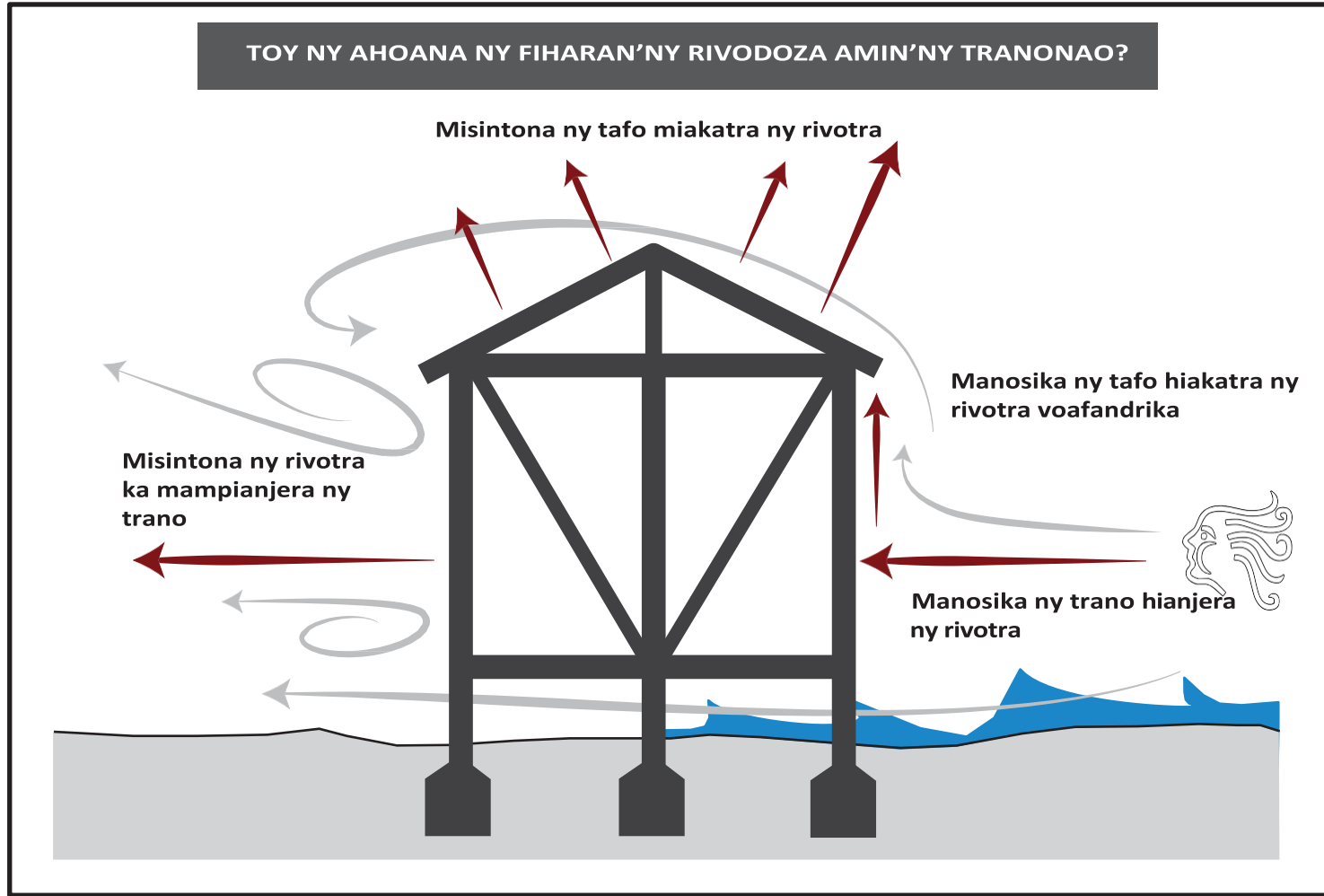

4

## FAMPIASANA TONON-KAZO MATANJAKA

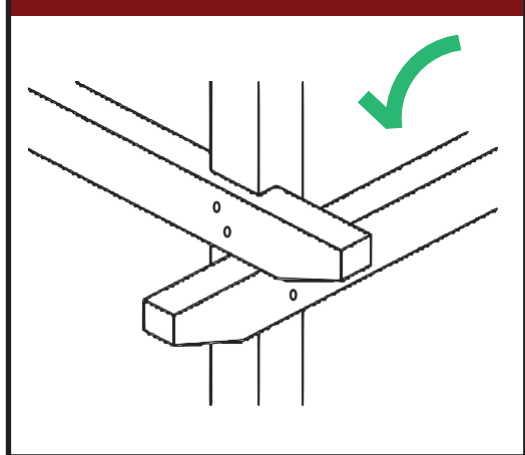

5

## FANAFOANA TSARA NY TRANO

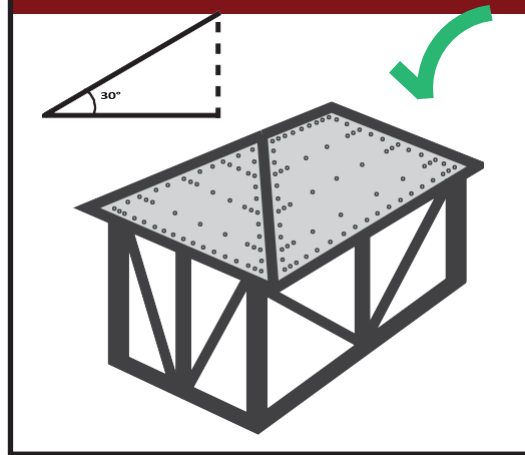

8

## FIOMANANA

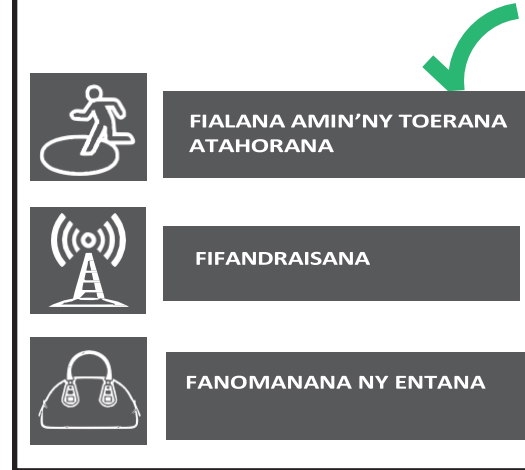

7

## TRANO MIENDRIKA TSOTRA DIA MAHARO ANAO

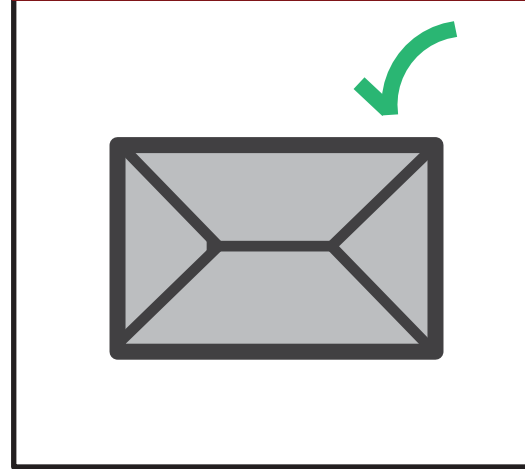

6

## FANORENANA TRANO AMIN'NY TOERANA AZO ANTOKA



**Fanorenana amin'ny tany mafy**

Tena zava-dehibe ny fototra satria mampifamatotra ny trano amin'ny tany. Ny fiantohana fa mifanaraka amin'ny toerana misy ny tranonao sy ny toetry ny tany ny fototra dia miaro ny tranonao amin'ny rivotra mahery, ny horohoron-tany ary ny tondra-drano.

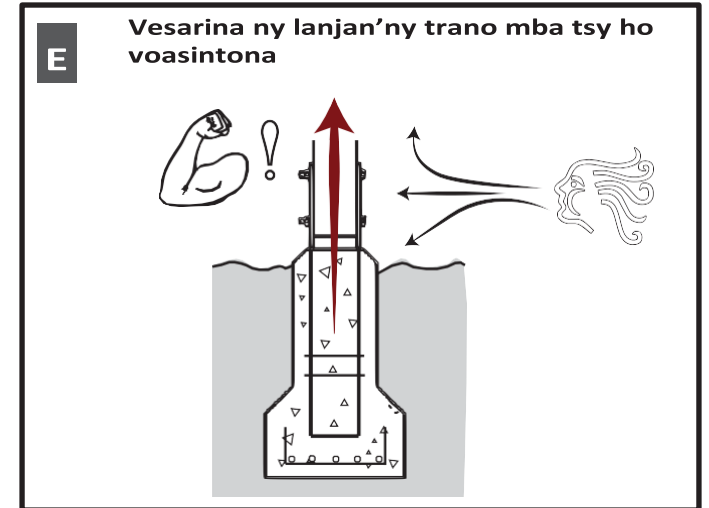
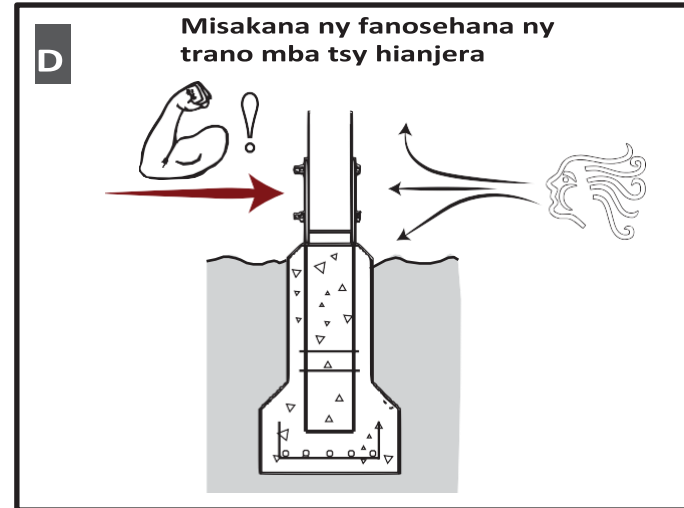
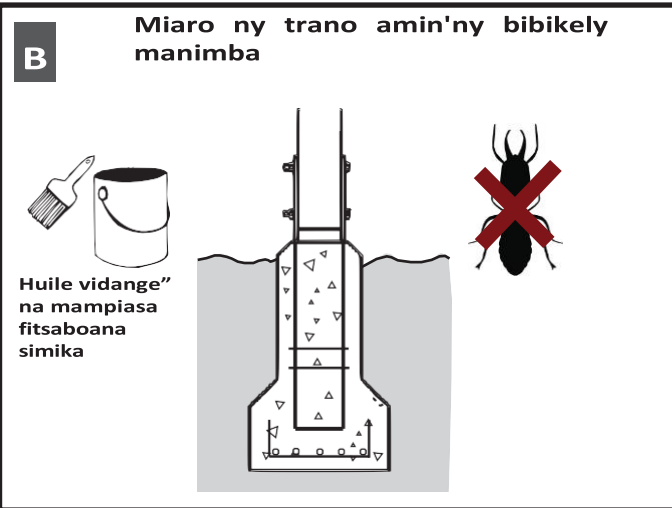
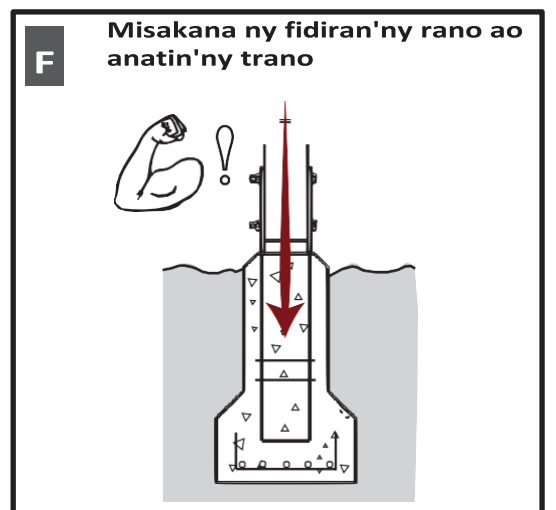
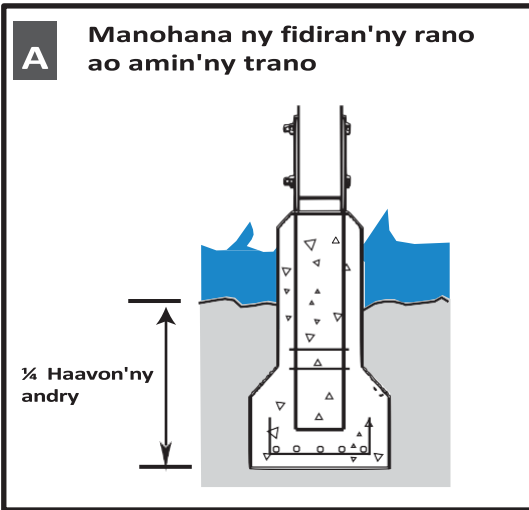

**INONA NO AZOKO ANAMAFISANA HO FOTOTRY NY TRANOKO?**

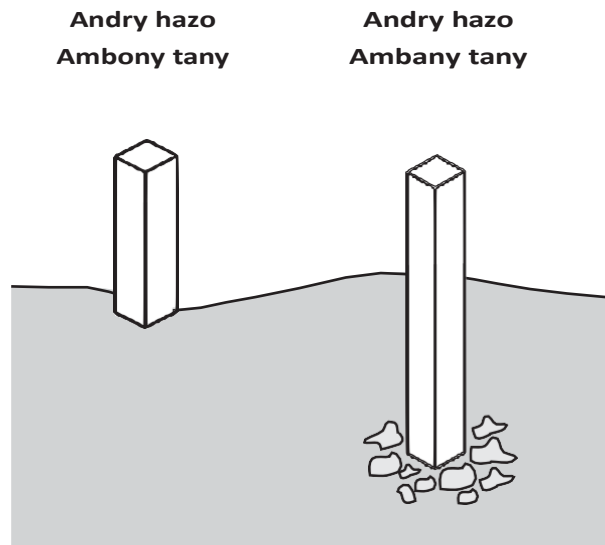

Malemy loatra **X**

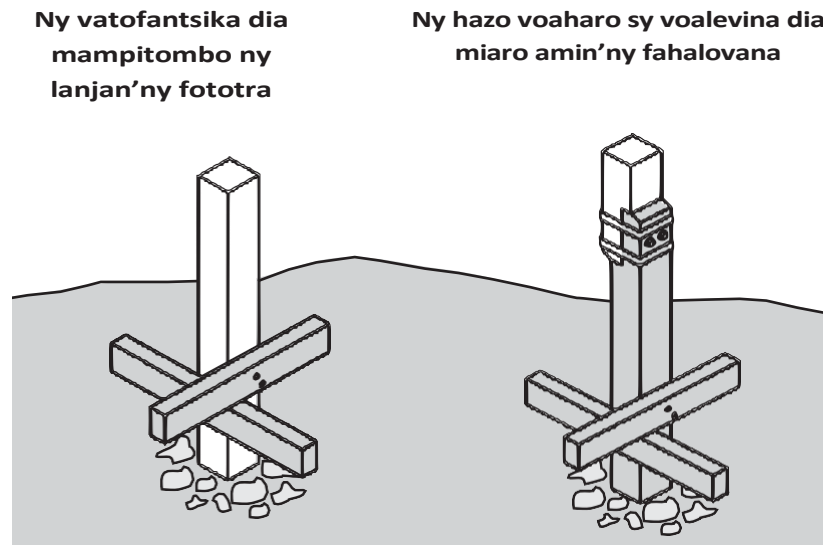

Matanjaka ihany **✓**

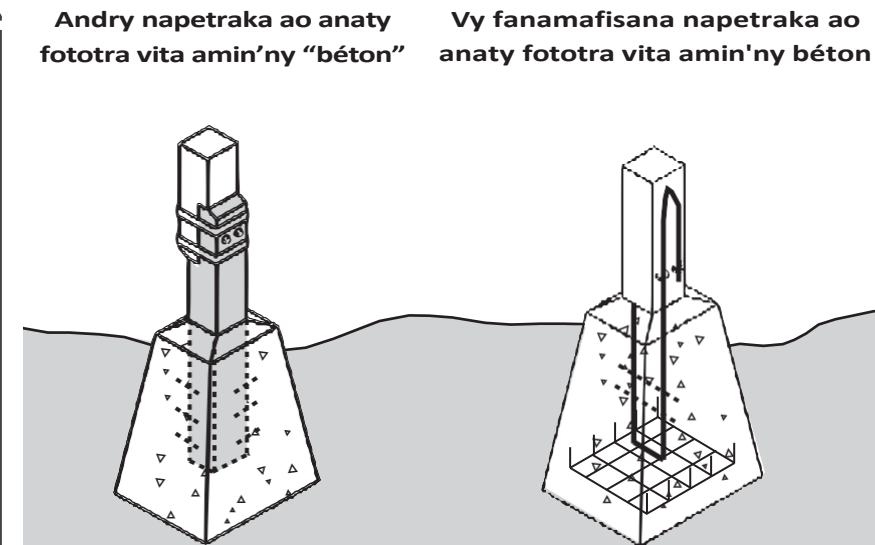

Matanjaka kokoa **✓**



Matanjaka indrindra **✓✓**

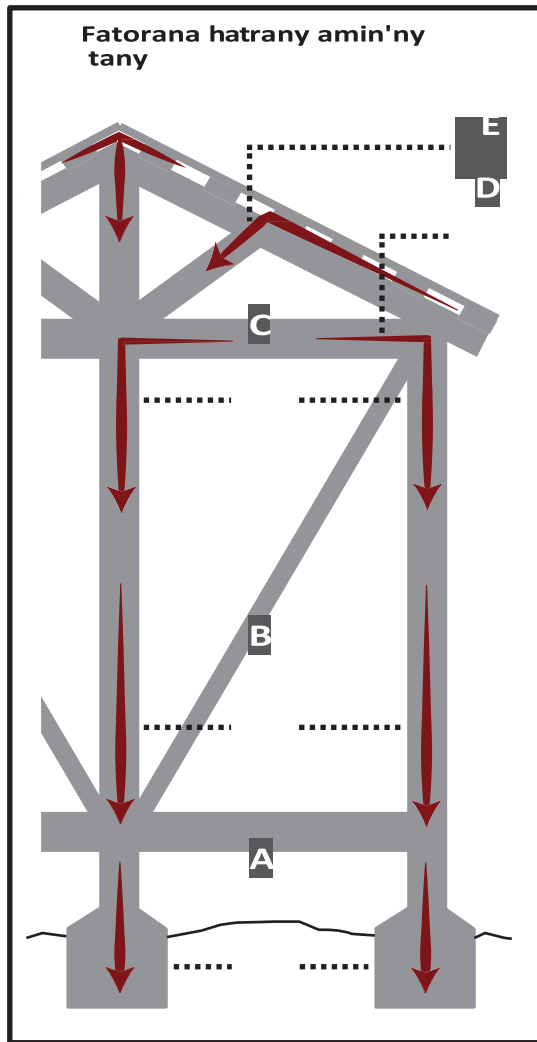

**Famatorana miainga avy amin'ny ambany hatrany ambony**

Amin'ny fotoanan'ny rivo-doza, mety ho voasinton'ny rivotra ka hirodana na ho levon'ny rivotra ny tranonao. Fatory hatrany amin'ny tany ny tranonao. Atomboy avy any ambany izany ary ampiakaro

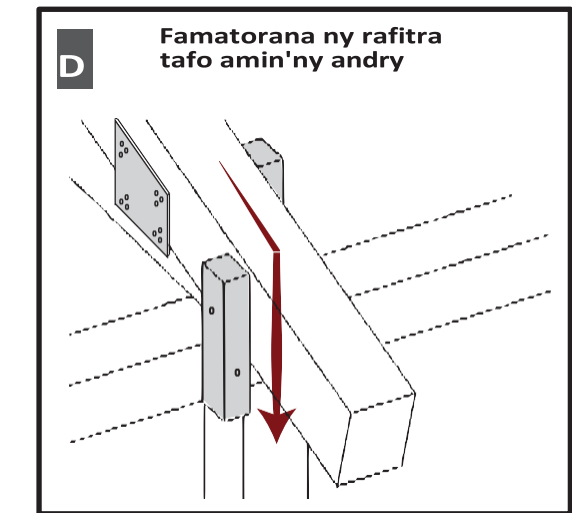
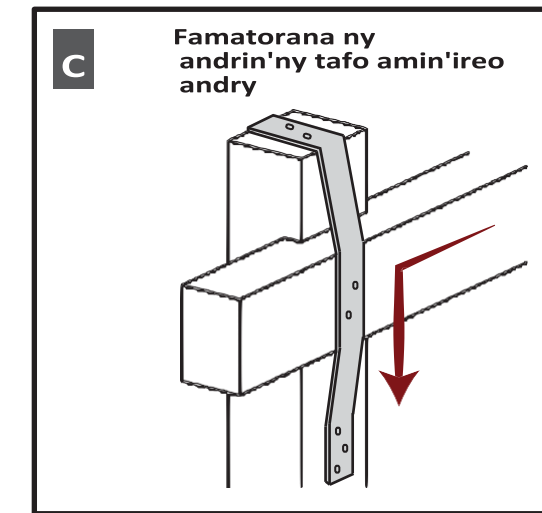
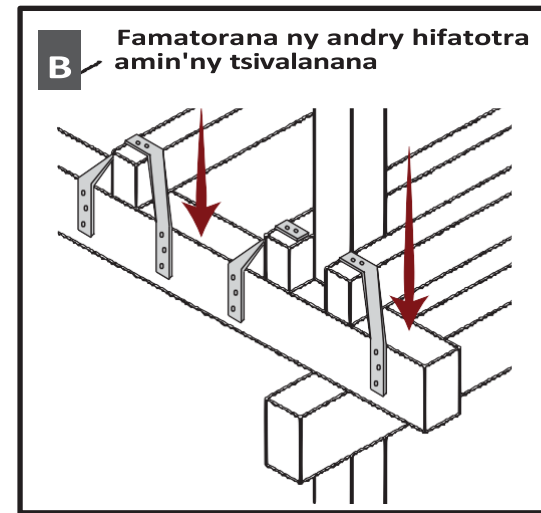
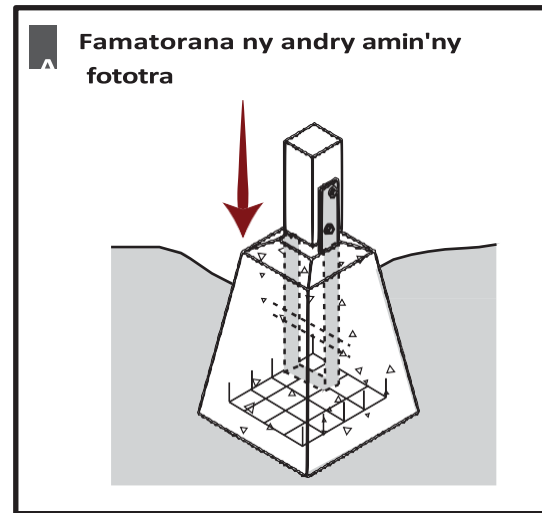
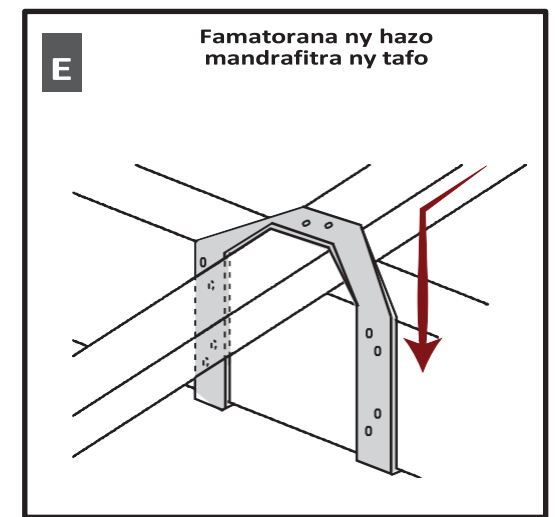

**INONA NO AZOKO AMPIASAINA HAMATORAKO NY TRANOKO?**

**MISY RIVOTRA MAHERY HO AVY?**

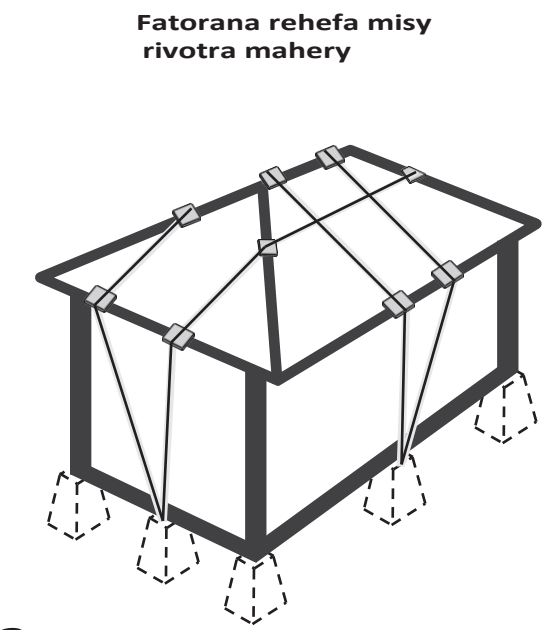
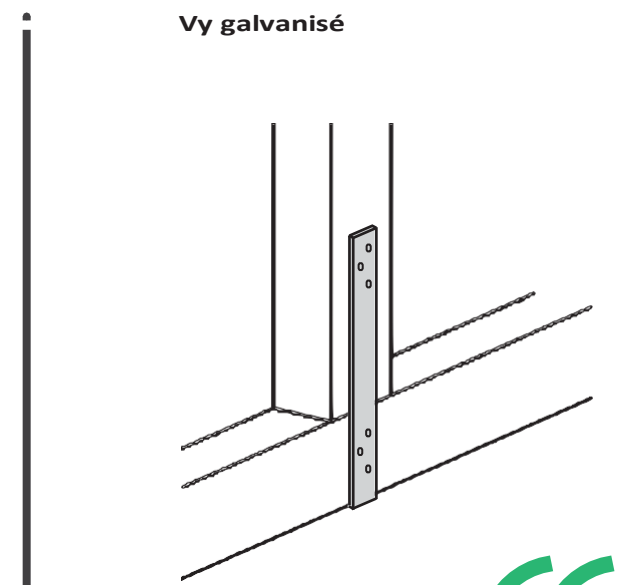
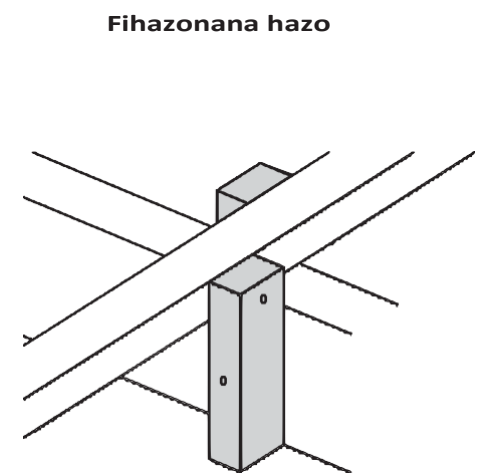
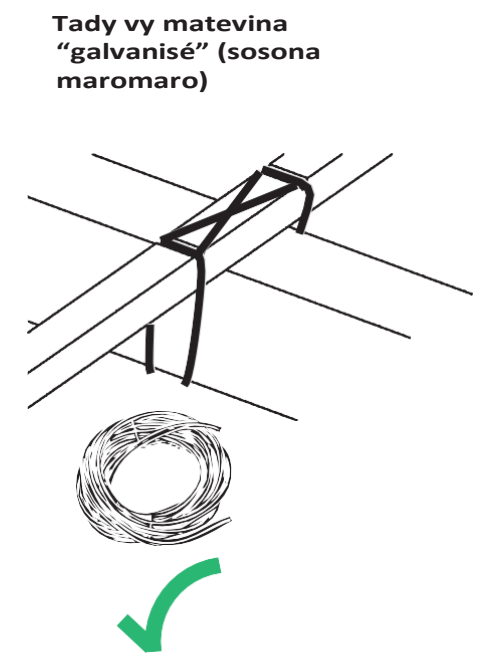
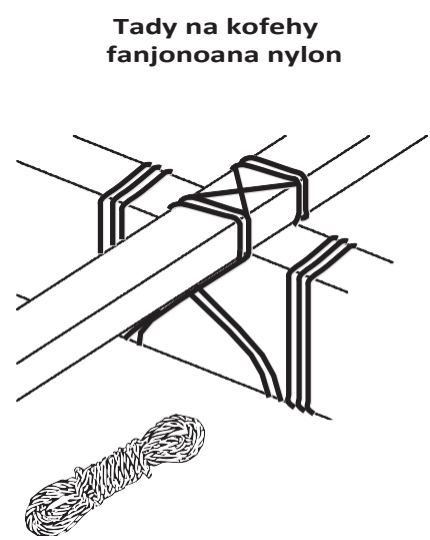

indrindra

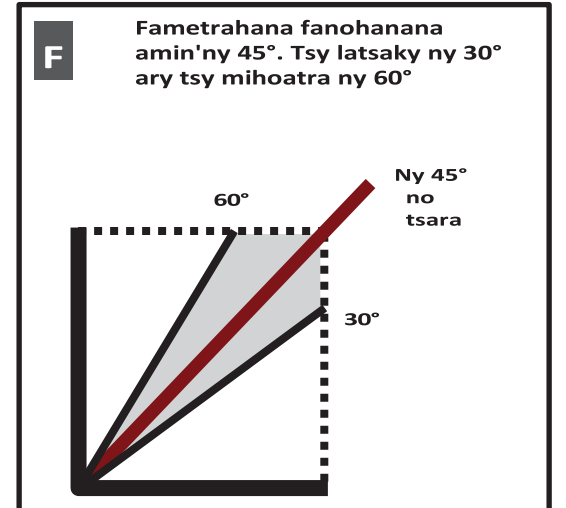
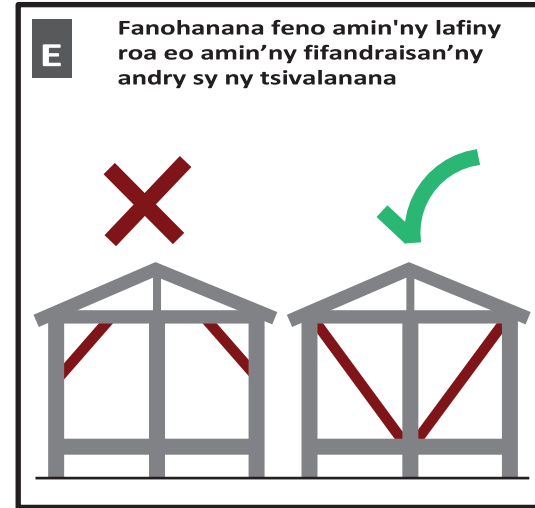
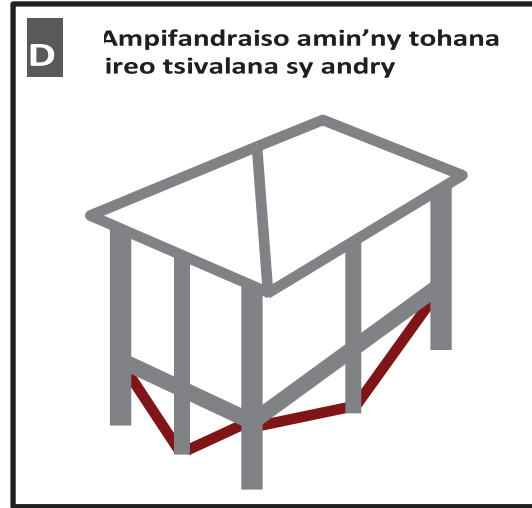
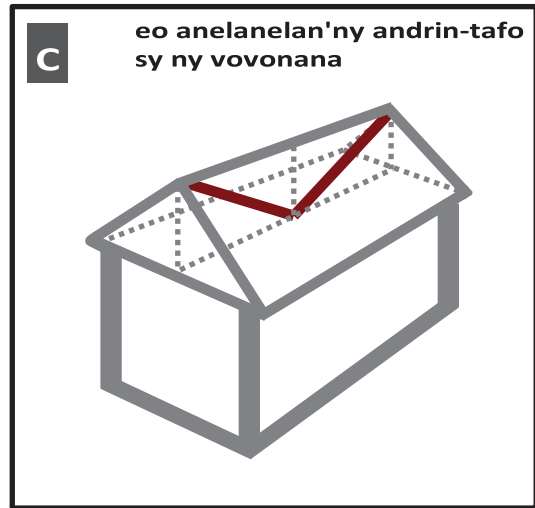
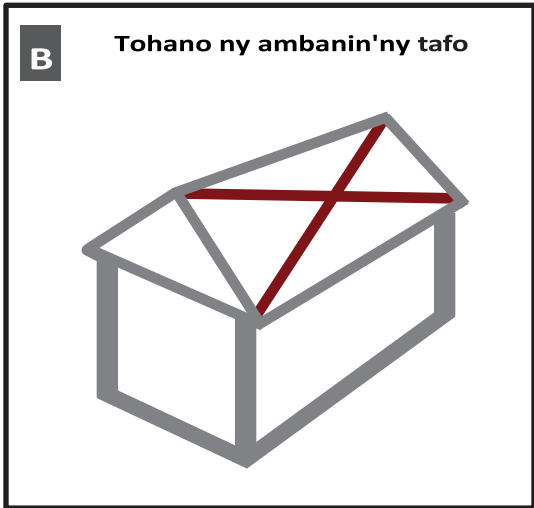
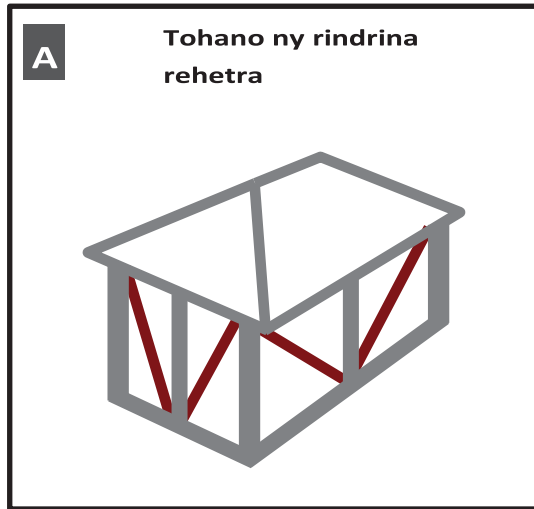

**Fanohanana, fiarovana amin'ny rivotra mahery**

Ny fanohanana matanjaka dia misoroka ny fanosehana na fisintonana ny tranonao hianjera na hisaraka nohon'ny rivotra. Tokony ho matanjaka ny fanohanana mba tsy ho potika na hisaraka ny trano.

Asio fanohanana eo anelanelan'ireo fanambarana hampatanjaka ny tranonao.

**INONA NO AZO AMPIASAINA ANOHANAKO NY TRANOKO?**

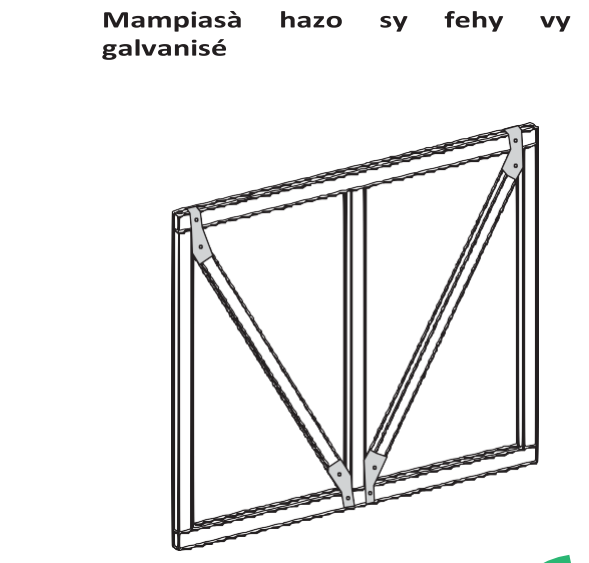
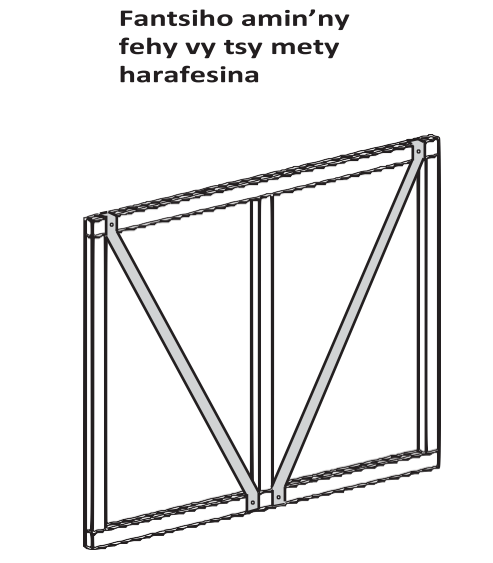
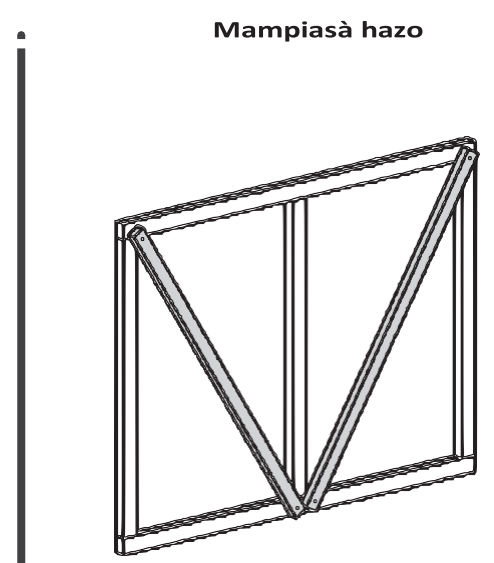
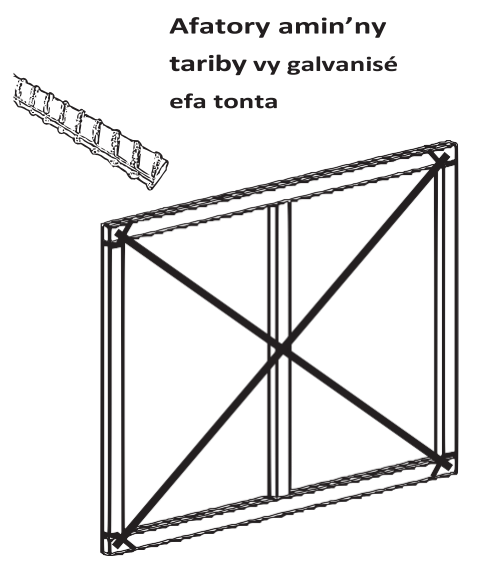
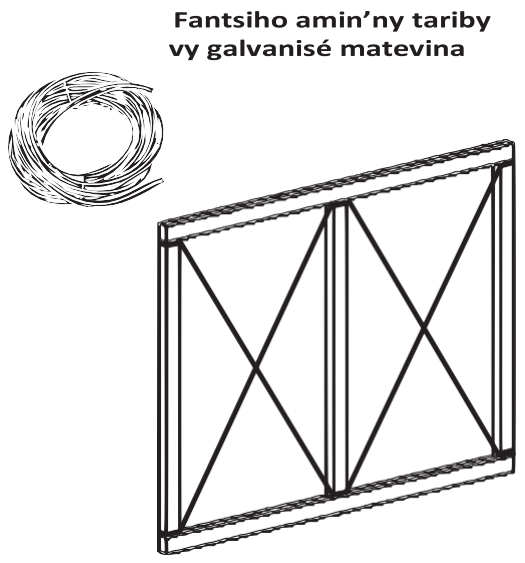

Matanjaka

Matanjaka kokoa

Matanjaka indrindra



**A** Mampiasa hazo mihoatra ny tonon-kazo mba hisorohana ny fahavavisan'ny hazo vokatry ny fantsika



**Fampiasàna tonon-kazo matanjaka**



Ny tanjaky ny tranonao dia miankina indrindra amin'ny fifamatoran'ireo singa mandrafitra azy. Ataovy matanjaka ny fifamatorana tsirairay mba tsy ho voatosika na voasintona ka hisaraka. Tsara kokoa ny fantsika mitsivalana satria tsy ho voasarika hiakatra na hidina nohon ny rivotra izany.



**F** Mampiasà takelaka fanamafisana hanamafisana ny tonony

**B** Aza andrimbinana be loatra ny andry na ny tsanganana lehibe

**C** Tsy alahatra ny fantsika rehefa mamantsika

**D** Ny famantsiana misopirana dia hanamafy ny fifandraisana

**E** Fampifandraisana amin'ny takelaka sy fehy mitsangana sy mitsivalana mba hampitomboana ny tanjaka

**INONA NO AZO AMPIASAINA HANAMAFISAKO NY FANAMBARANA HAZO?**

Fantsika tokana

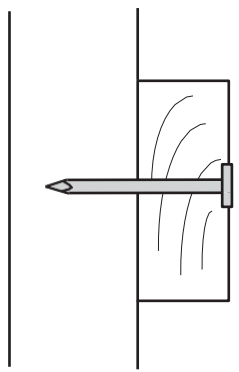

Malemy loatra **X**

Fantsika roa

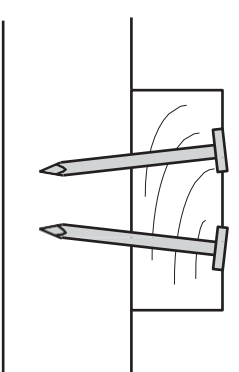

Matanjaka **✓**

Vis

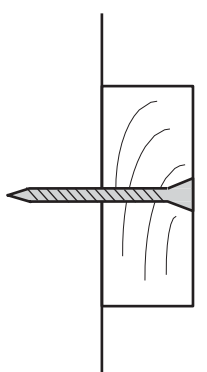

Fifandraisana mifampiditra tsara sy fantsika

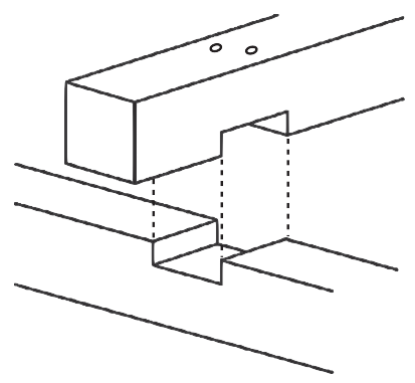

Matanjaka kokoa **✓**

Takelaka vy

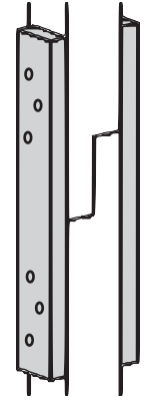

Bilao sy « ecrou »

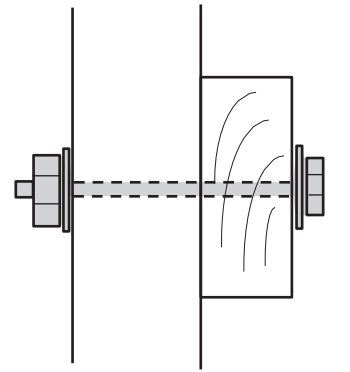

Matanjaka indrindra **✓**





## Fanafoana tsara ny trano



Ny fomba famolavolana sy fananganana ny tafonao dia tena zava-dehibe mba hiarovana anao amin'ny rivotra mahery sy ny orana. Ataovy amin'ny endrika sy fihantonana mety ny tafonao, ary kapohina tsara amin'ny fantsika mba hiarovana amin'ny tafiotra.

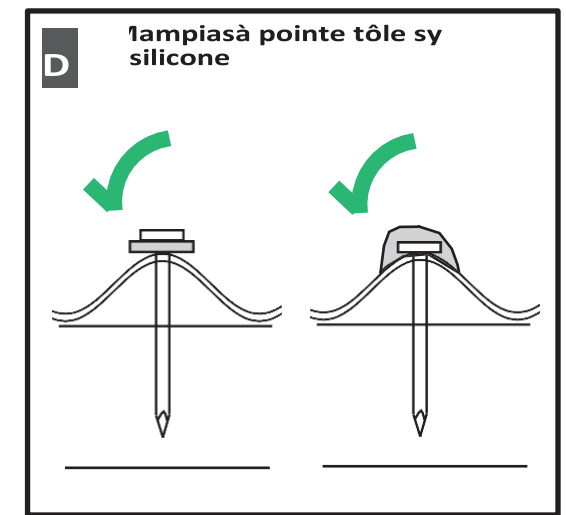
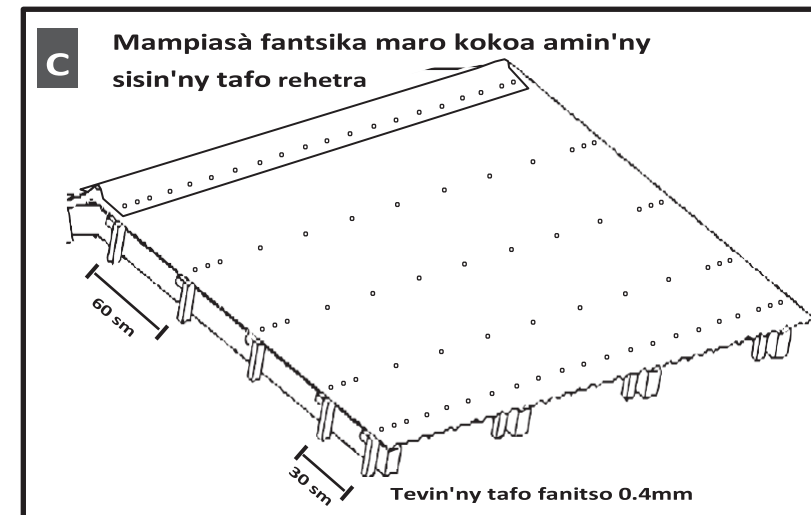
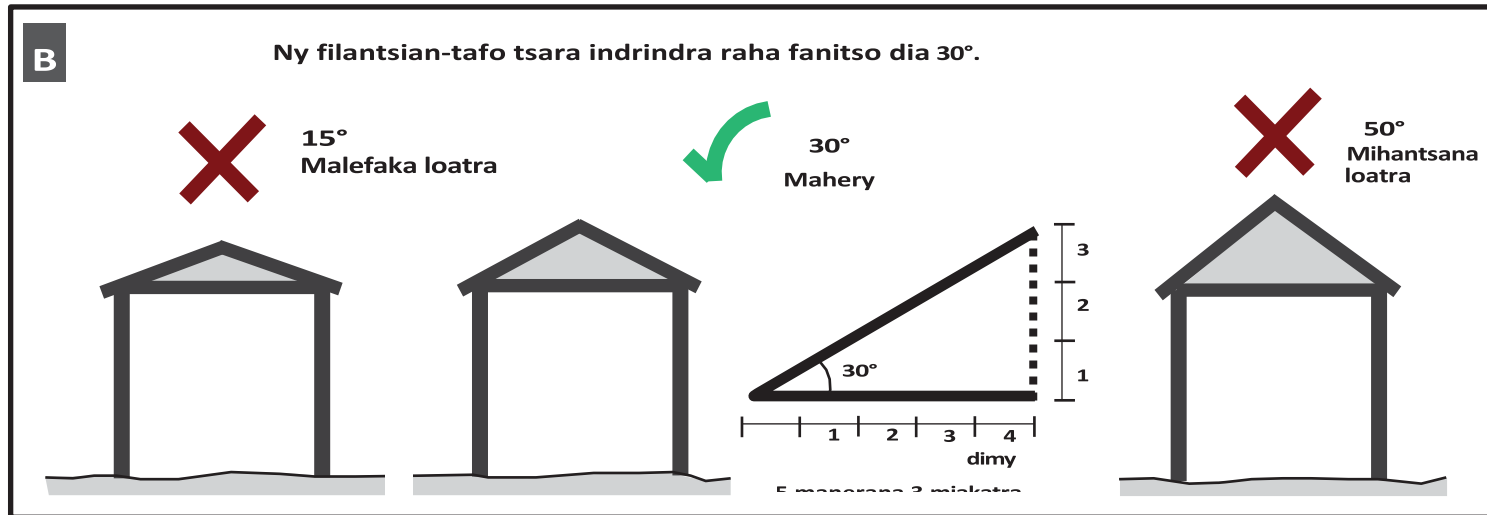
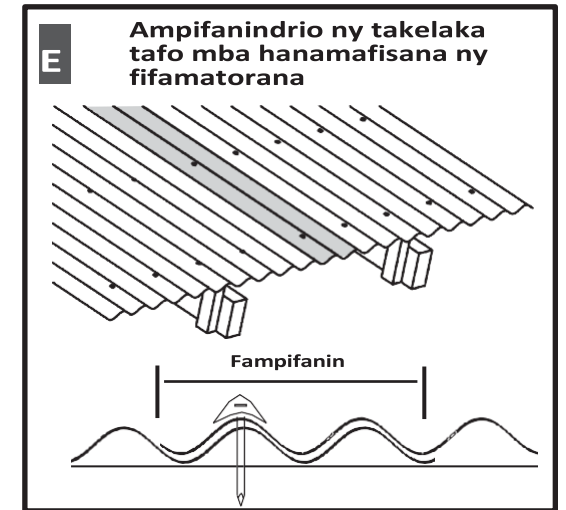

### INONA NO AZOKO AMPIASAINA HANAMAFISAKO NY TAFO?

### INONA NO ENDRIKAN'NY TAAFAOKO?

Fantsika mahazatra	Fantsika ary peratra vy (tsara ho an'ny bambou)	Fantsika-tafo misy miendrika elo eo amin'ny lohany ho fanariana rano	Bilao miampy "rondelle"
Malemy loatra <b>X</b>	Matanjaka <b>✓</b>	Matanjaka indrindra <b>✓✓</b>	

Lafy tafo iray	Tafo misy lafiny roa	Tafo misy lafiny efatra
Malemy loatra <b>X</b>	Matanjaka <b>✓</b>	Matanjaka indrindra <b>✓✓</b>

Malemy loatra      Matanjaka      Matanjaka indrindra



**Aoreno amin'ny toerana azo antoka ny tranonao**



Fantaro ireo loza mety hitranga eo amin'ny toerana misy anao ary manaova trano mafy araka izay tratra mba hiatrehana izany.

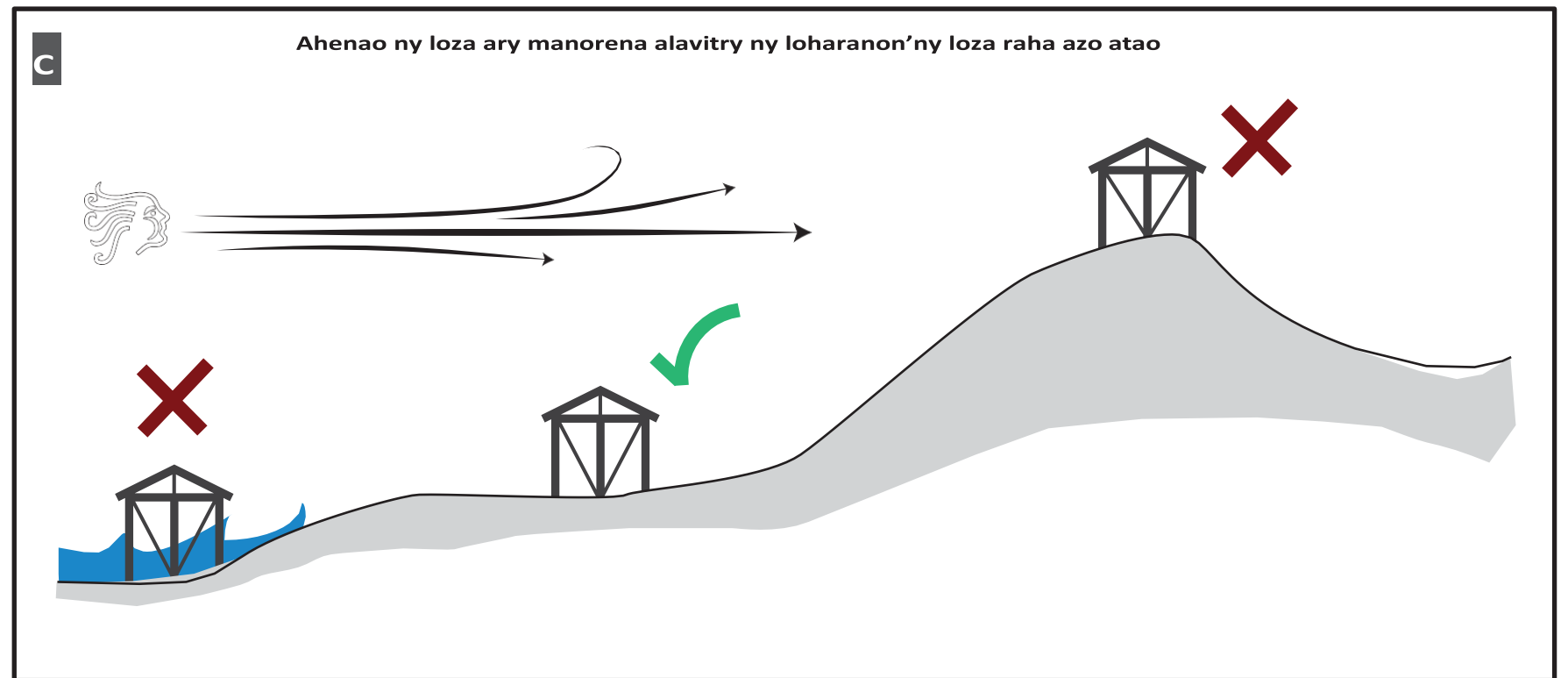
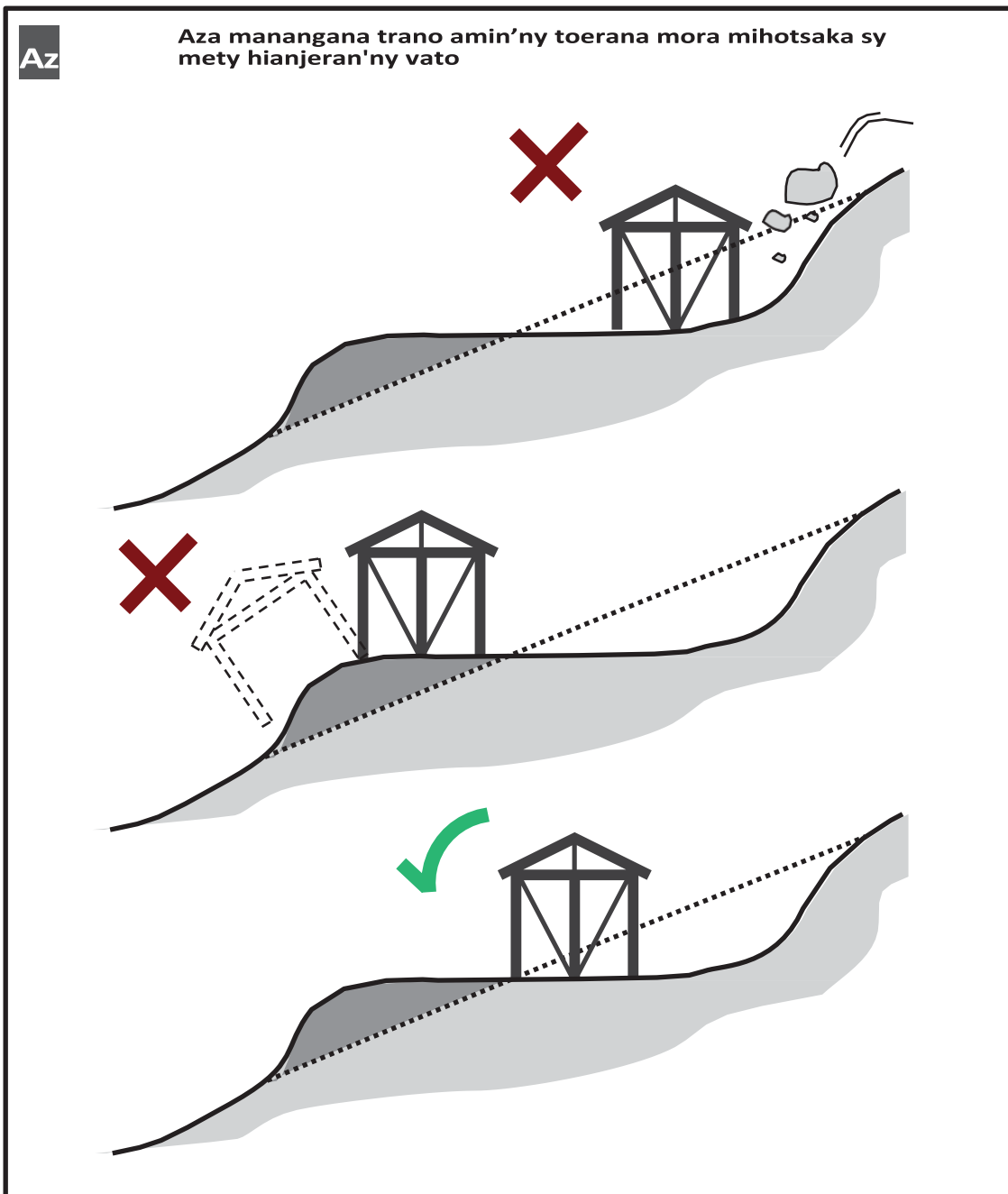

**A** Ny fiholika fanampiny amin'ny trano dia manalefaka ny tanjany

**Trano miendrika tsotra dia maharo anao**

Zava-dehibe ny endriky ny tranonao mba hampihenana ny fahasimbana amin'ny rivotra mahery. Ataovy tsotra sy matanjaka foana ny endriny.

**B** Ny endrika tsotra sy mifintina no azo antoka indrindra

Ny halavany tsy mihoatra ny in-telo ny

**C** Aza atao lava loatra

**D** Tsara raha misaraka amin'ny tafo lehibe ny ribany

**AHOANA NO TOKONY HAMETRAHANA NY TRANO?**

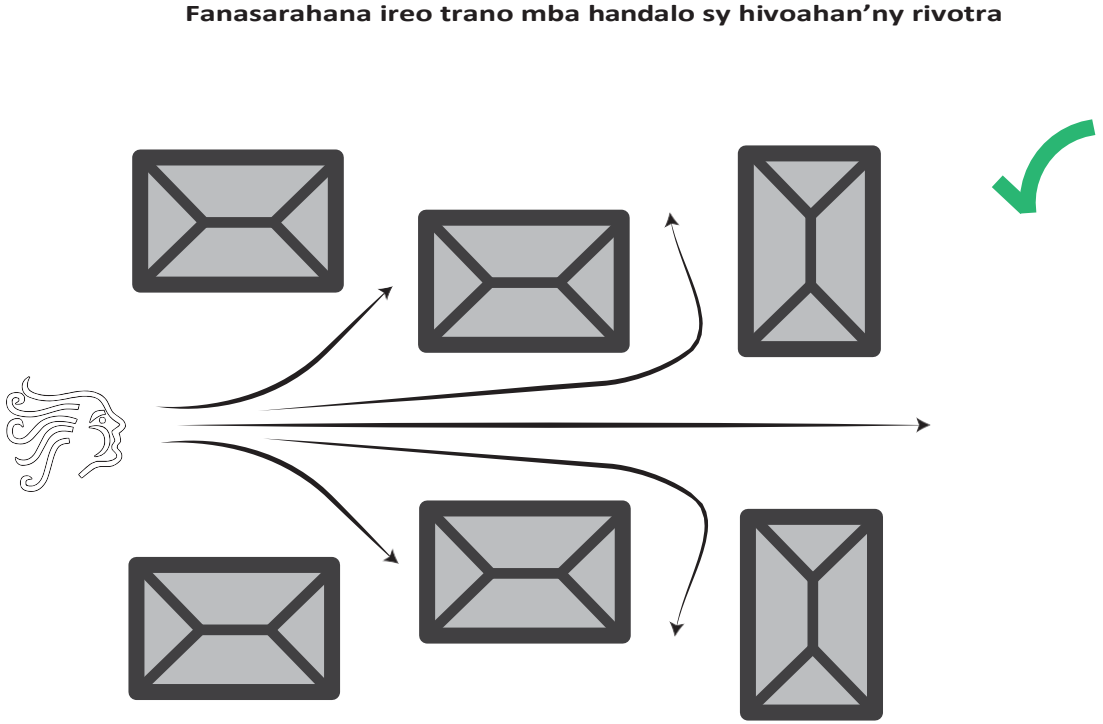
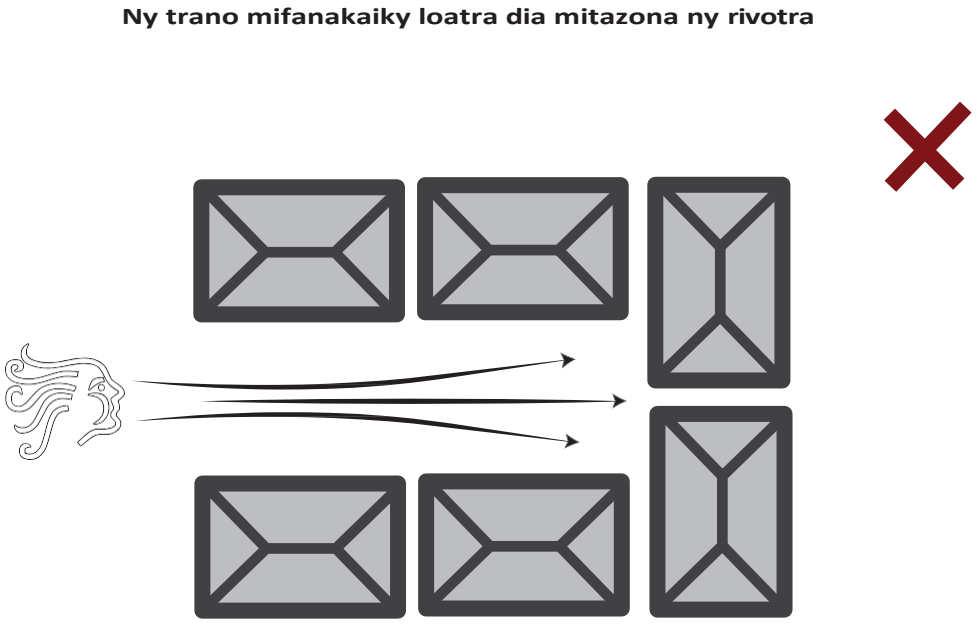

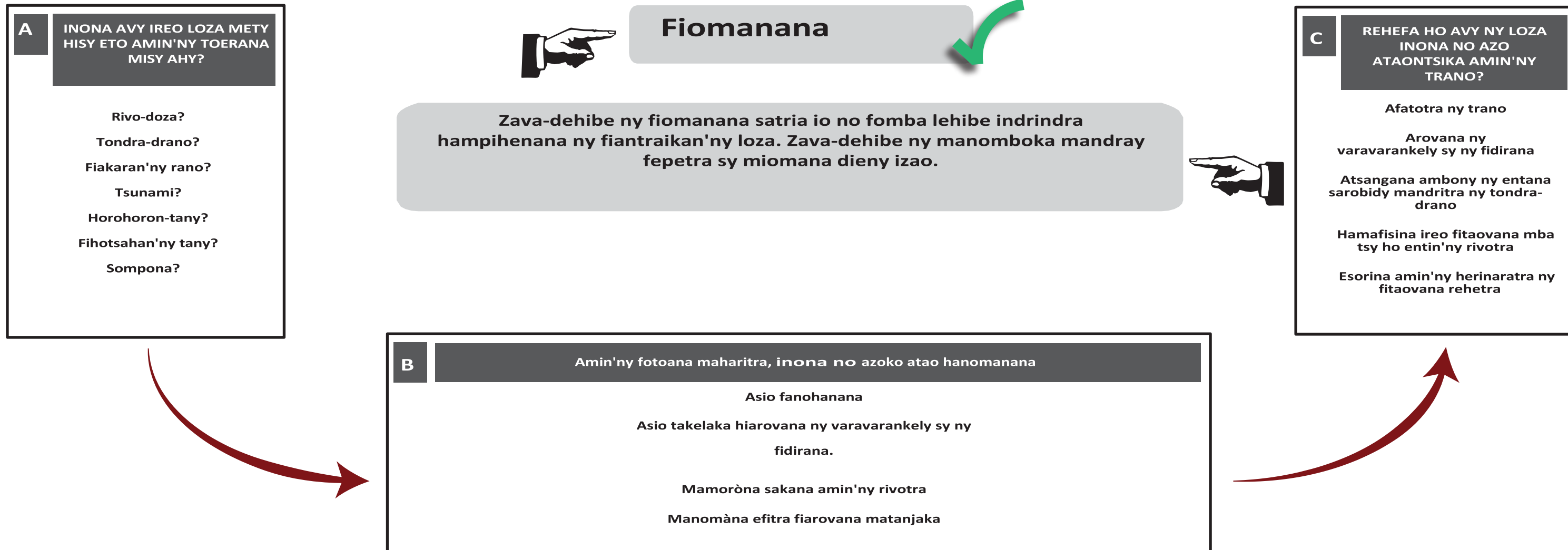

**AHOANA NO AFAHANAY SY NY MPIARA MONINA AMIKO HIATRIKA NY LOZA?**



**FILEFANA**

- Manaova drafitra ary ampiharo izany
- Manapaha hevitra mialoha raha hiala na hijanona eo an-toerana
- Manomana lalana fialana azo antoka
- Fantaro hoe aiza ireo toerana fialofana
- Fantaro izay fitaterana azonao ampiasaina



**FIFANDRAISANA**

- Fantaro ireo famantarana fampitandremana momba ny loza
- Fantaro ny fomba ahafahanao mahazo fampahalalana momba ny loza
- Ampahafantaro ny havanao sy ny namanao hoe aiza ianao no handositra
- Fantaro ny fomba hifandraisanao amin'ny havana sy ny namana aorian'ny loza
- Fantaro ny fomba sy ny olona ampahafantarina ny toe-javatra misy anao aorian'ny loza
- Fantaro hoe aiza no ahitana fampahalalana momba ny olona very



**ENTANA HIOMANANA**

- Manomana kitapo vonjy taitra tsy tantera-drano mialoha ny loza
- Ataovy mora entina ny 'kitapo vonjy taitra' ary ampidiro ao anatin'ny:
  - kitapo fitaovam-pitsaboana
  - akanjo fanampiny sy kiraro azo antoka,
  - jiro sy labozia sakafo fototra
- fitaovana fandrahoan-tsakafo fitaovana fototra
- antontan-taratasy manan-danja manokana/karapanondro
- Aza adino ny rano kely