

DOMES CONSTRUCTION

For further information on dome construction
Please contact:



**UNITED NATIONS CENTRE
FOR HUMAN SETTLEMENTS
(UNCHS - HABITAT)**

PO Box 30030, Nairobi, KENYA
Phone: (254-2) 621234
Fax: (254-2) 624265
E-mail: Rainer.Nordberg@unchs.org



**AUROVILLE BUILDING CENTRE
(AVBC / EARTH UNIT)**

Auroshipam, Auroville - 605 101
Tamil Nadu, INDIA
Phone: +91 (0)413-622277 / 622168
Fax: +91 (0)413-622057
E-mail: csr@auroville.org.in

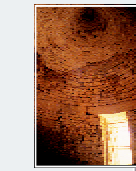

Treasure of Atreus - Tomb of Agamemnon (Ø +/- 18m)
Mycene, Greece (c/- 1500 BC)



Blue mosque, XVI century - Istanbul, Turkey
(Ø 23.50 m, 43 m high)



Office, Auroville, India
(3.63 m side, 0.60 m rise)



Sainte Sophia, VIIth Century - Istanbul, Turkey
(31-32 m side, 55 m high)

Dhyanalingam Temple - Coimbatore, India
elliptical section (Ø 22.16 m, 9.85 m high)

School - Auroville, India
(5.70 m side, 2 m rise)

Application of Domes:

- Plain masonry built with blocks or bricks
- Floors for multi-storey buildings, they can be leveled flat
- Roofs, they can be left like that and they will be waterproofed
- Earthquakes zones, they can be used with a reinforced ringbeam

They are Built Free Spanning:

- It means that they are built without form
- This way is also called the Nubian technique

Timber Saving:

- Domes are built with bricks and blocks (rarely with stones)

Variety of Plans and Shapes:

- Domes can be built on round, square, rectangular rooms, etc.
- They allow a wider variety of shapes than vaults

Stability Study:

- The shape of a dome is crucial for stability, and a stability study is often needed. Be careful, a wrong shape will collapse

Need of Skilled Masons:

- Building a dome requires trained masons. Never improvise when building domes, ask advice from skilled people
- Be careful, a badly built dome may collapse

Need of Good Quality Materials:

- Domes built with compressed earth blocks should be made of blocks of very regular thickness

BASICS FOR DOMES

Variety of Shapes

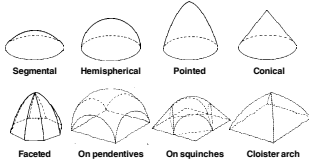

Terminology

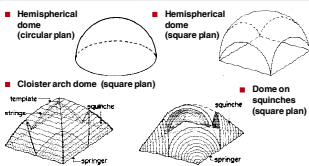

Basic Structural Principles

Generality:

- A dome is composed of a series of rings, resting on each other
- A dome is characterized by a thrust, with pushes on the walls

Two forces are acting in a dome:

- The thrust (T), which pushes down with an angle on the walls
- A concentric thrust (CT), which acts in every ring and compresses it

The thrust (T) is composed of 2 forces:

- A horizontal force (HT), which tends to push the walls apart
- The weight (W), which is the weight of the masonry

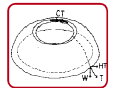

Technique Basics:

- The clay which is present in a soil binds a brick or block
- This technique can use adobe (sun dried bricks), stabilized CEB (compressed earth blocks), or fired bricks
- The blocks must be dry before starting the block laying process
- The mortar is like a glue, it is very sticky; clay is the binder
- The mortar contains more soil than sand, and some cement
- The cement does not help for adhesion, the clay does it
- Mortar proportions will vary according to the soil quality
- The mortar thickness should not exceed 2-3 mm

Suitability of Domes

Hemispherical dome

- It often needs a tie ring
- The round wall can be a difficulty
- If it is for an exposed roof, the waterproofing often cracks

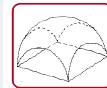

Hemispherical dome on pendentives

- It is advised to use a tie beam
- It needs arches
- If the segmental sphere is the roof, the waterproofing often cracks

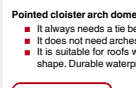

Pointed cloister arch dome

- It always needs a tie beam
- It does not need arches to support it
- It is suitable for roofs with a pyramidal shape. Durable waterproofing



Segmental cloister arch dome

- It always needs a tie beam
- It does not need arches to support it
- Suitable for floors of apartments in multi-storey buildings

Typical Square Dome for Village House

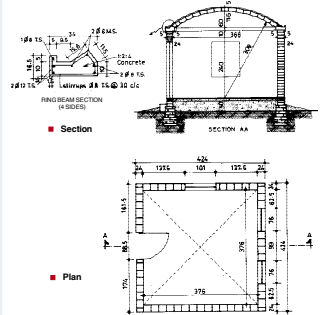

- These dimensions and specifications must be rigorously respected! Any disregard to them may cause collapse...

BUILDING A CIRCULAR DOME

1. Setting up the Compass

- Adjust the sliding guide at the proper radius
- Support the compass in the centre
- The compass level (articulation) is at the same level as the springer level

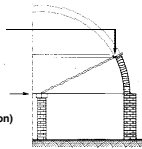

2. Detail of a Compass

- Wooden reaper (4 x 4 cm x 4 m)
- Sliding pipe (45 x 45 x 45 mm) with a nut welded and a bolt
- Articulation with flat steel and 2 bolts welded at 90°
- Supporting plate with a pipe welded at 90°
- Block to support the compass and adjust it in the centre

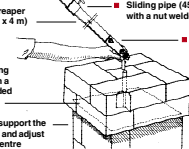

3. Soaking the Block and Laying the Glue

- Soak the block for 2 seconds just before laying it. It will start a capillary action which will suck the glue in
- The glue is made of soil, sand, a little cement and a lot of water
- Immediately after soaking the block, apply 3-4 mm glue on it

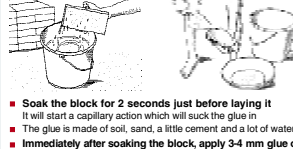

4. Stick the Block on the Masonry

- The previous course must be humid
- 0 mm
- Blocks must touch each other in their lower part: Intrados = 0 mm mortar for the side joint. The laying mortar must be thin (2-3 mm)



5. Adjust the Block

- Handle the compass to check if the block is on the radius
- Adjust the block if needed

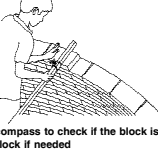

6. Wedge the Joints

- The outside joint must be wedged with a stone chip or pebble
- The wedge is inserted by hand and must be tight in the joint



7. Laying the Last Block

- Adjust the length of the last block
- It must touch on either side at the intrados - 0 mm of mortar
- Wedge tight, by hand, the outside of the joint

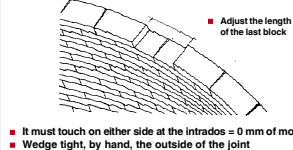

8. Starting a New Ring

- Start laying the blocks in the same way, but don't forget to cross the bonds

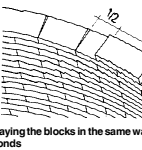

BUILDING A SQUARE DOME

1. Setting up the Template

- Template with steel pipes
- Lay the template in the corners, adjust it and pull the strings

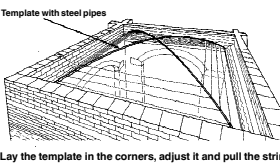

5. Adjust the Block

- Check that the block does not touch the string (1 mm below)

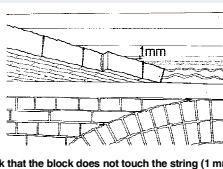

2. Soaking the Block

- Soak the block for 2 seconds just before laying it on the mortar
- The block start a capillary action, which suck the glue in

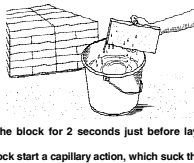

6. Wedge the Joints

- The outside joint must be wedged with a chip or pebble
- The wedge is inserted by hand and must be tight in the joint

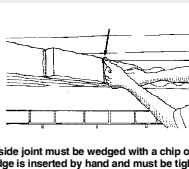

3. Laying the Glue

- The binder is glue, which is made of soil, sand, a little cement and a lot of water
- Immediately after soaking the block, apply 3-4 mm glue on it

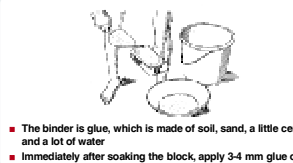

7. Laying the Keystone

- Adjust the block length and cross the bonds
- It must be touching at the intrados - 0 mm of mortar
- Wedge tight, by hand, the outside of the joint

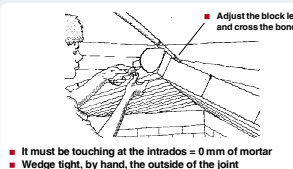

4. Stick the Block on the Masonry

- The previous course must be humid
- Blocks must touch each other in their lower part: Intrados = 0 mm mortar for the side joint. The laying mortar must be thin (2-3 mm)

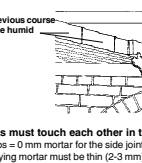

8. Starting a New Arch

- Lay the blocks in the same way, don't forget to cross the bonds
- Don't forget to build each arch and the dome symmetrically

