

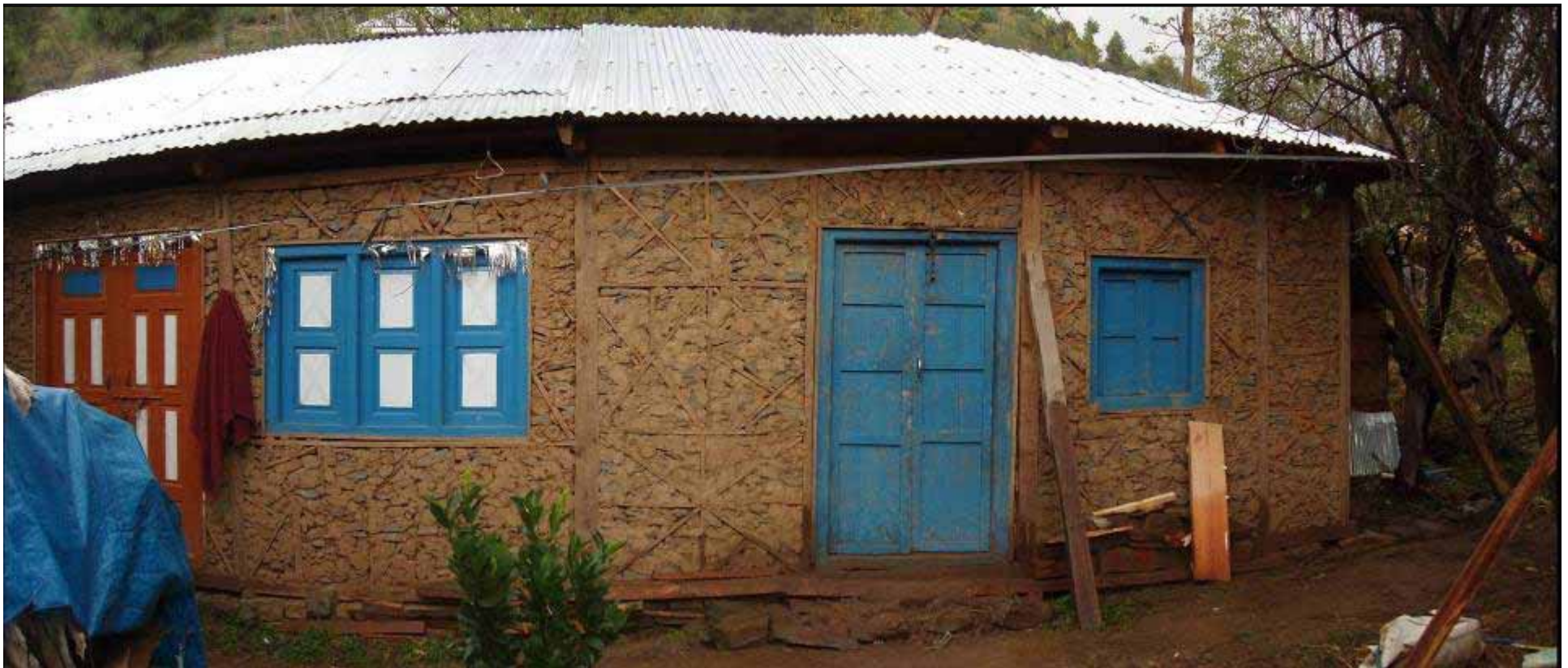

Version 13.12.06

Basic Training on Dhajji construction

(PowerPoint lesson)





Content

1. Concept of Dhajji
2. Foundations
3. Dasa (plinth beam)
4. The frame structure
5. Joints
6. Roof trusses
7. Walls and bracings
8. Windows and doors
9. Infills and plaster
10. Examples



1. Concept of Dhajji



What is Dhajji?

‘Dhajj’ means ‘patchwork quilt’



A Dhajji house is a patchwork of timber and stone





Why is a Dhajji wall strong?

In big panels, the energy is concentrated

In a usual house, an earthquake first makes:

- ONE BIG crack,
- then TWO BIG cracks,
- then the walls fall out.

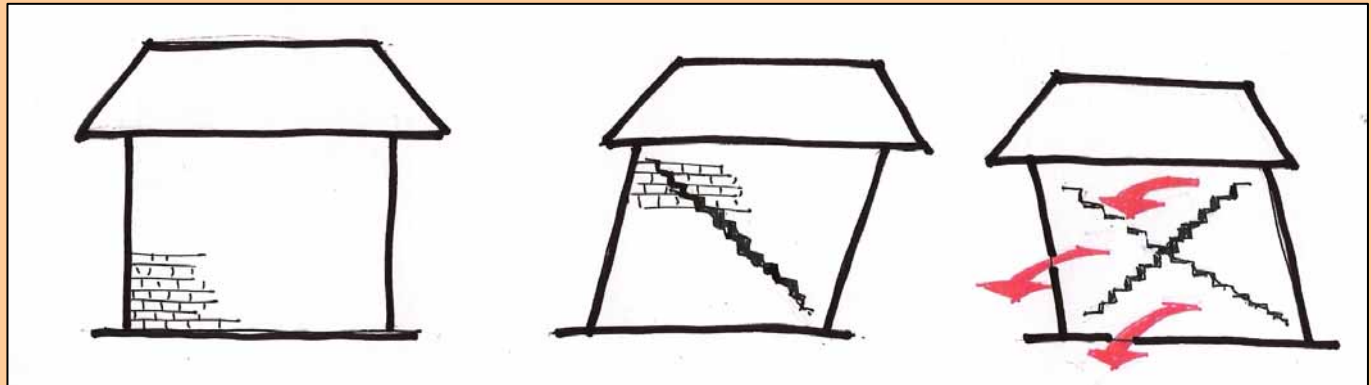

Small panels distribute the energy evenly

- In a Dhajji house, there are:
- many **SMALL** cracks,
- and only small parts fall out.
- **BUT THE WALLS REMAIN!**

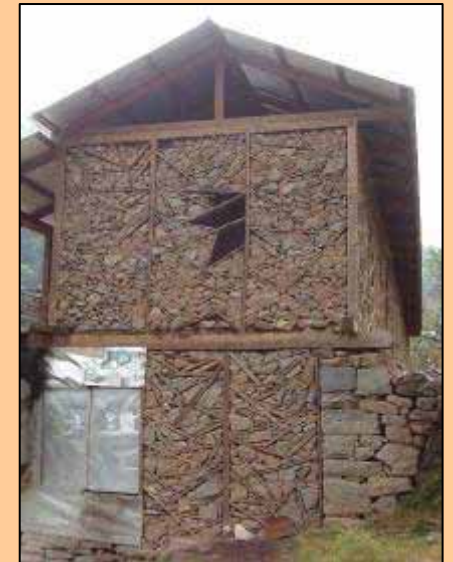
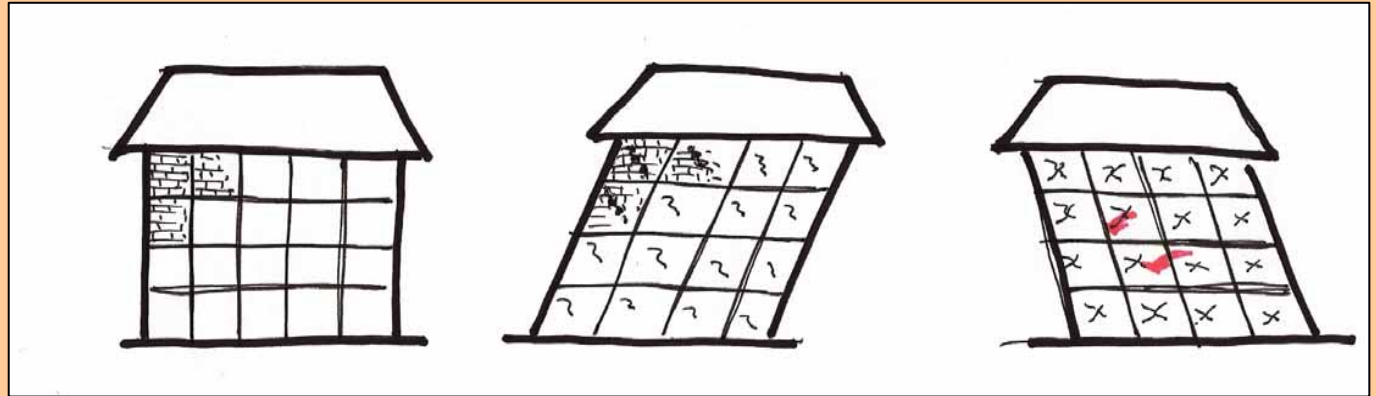

Friction breaks down the energy

- Do you prefer to hit a stone or a heap of sand?

Why?



Friction breaks down the energy

- A stone is hard.
- Either the stone breaks, or the hand.

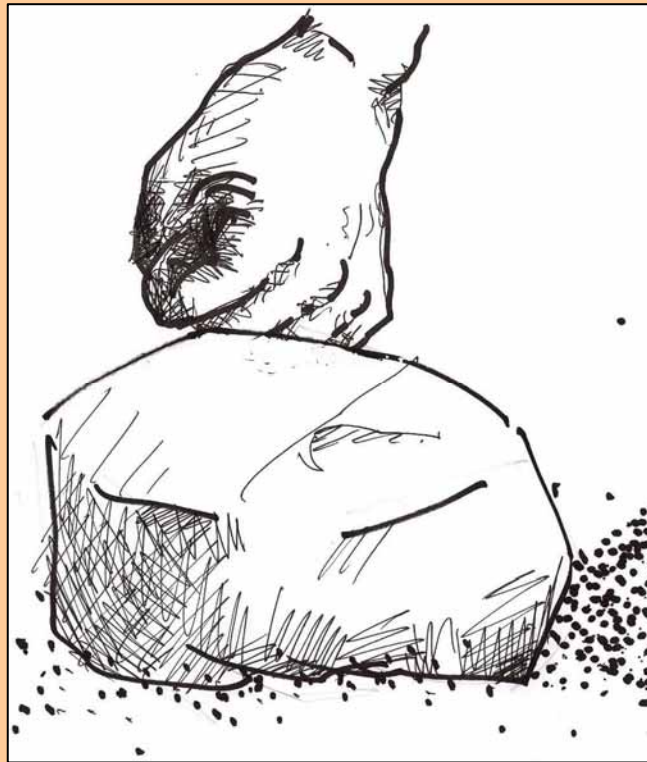

Friction breaks down the energy

- Grains of sand are also hard.
- But they will move away.

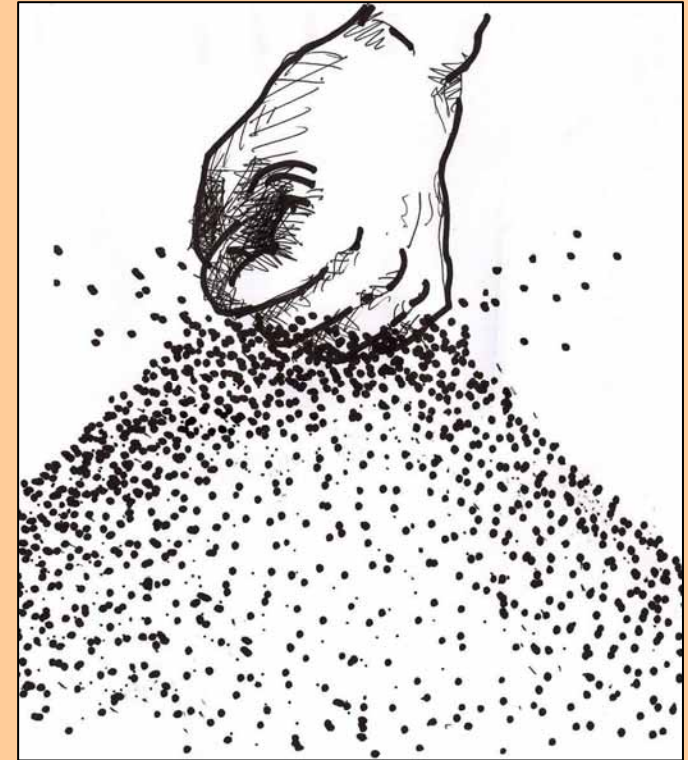

Friction breaks down the energy

- When a frame is deformed, the stones of the infill have to move away.

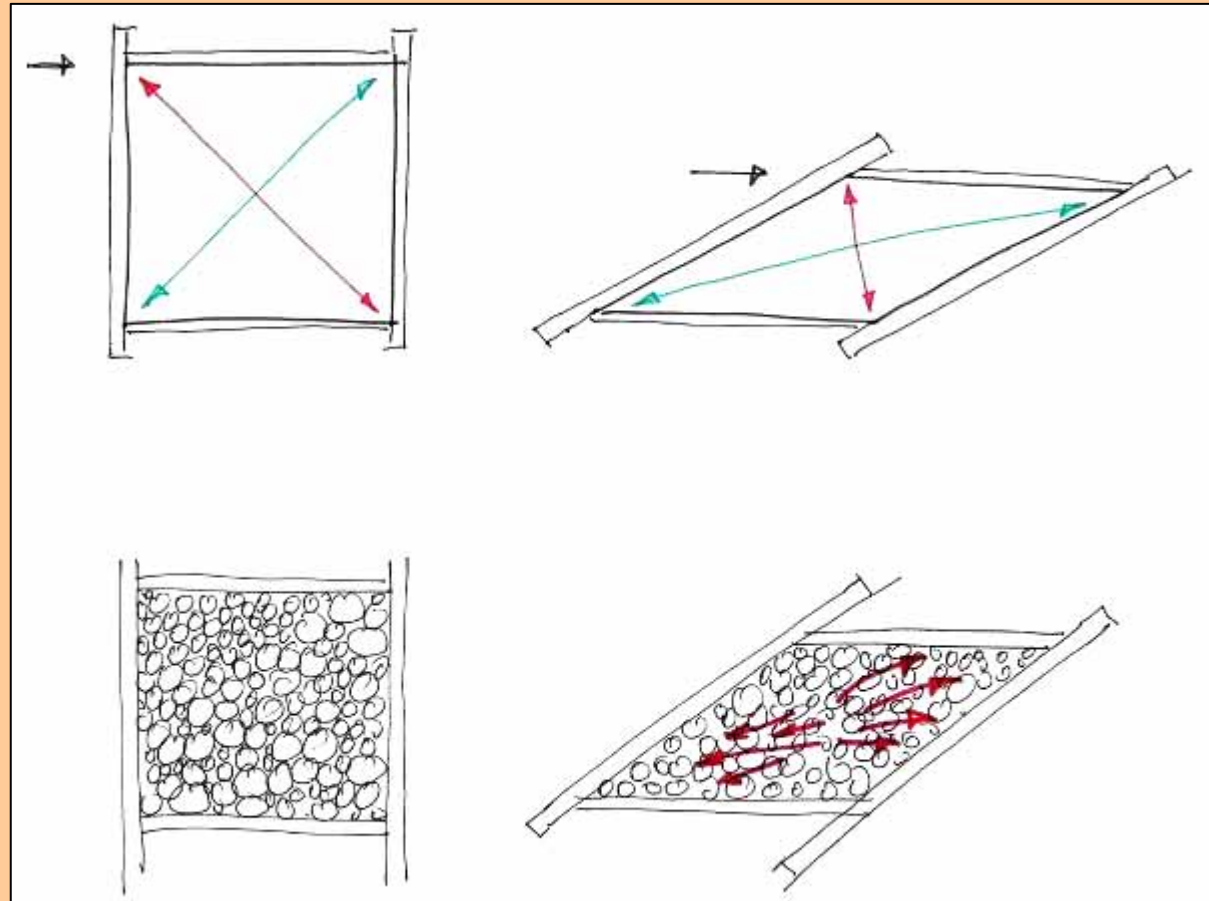

Friction breaks down the energy

- When the stones and the boards have to move, they rasp against each other.
- This friction dissipates energy.

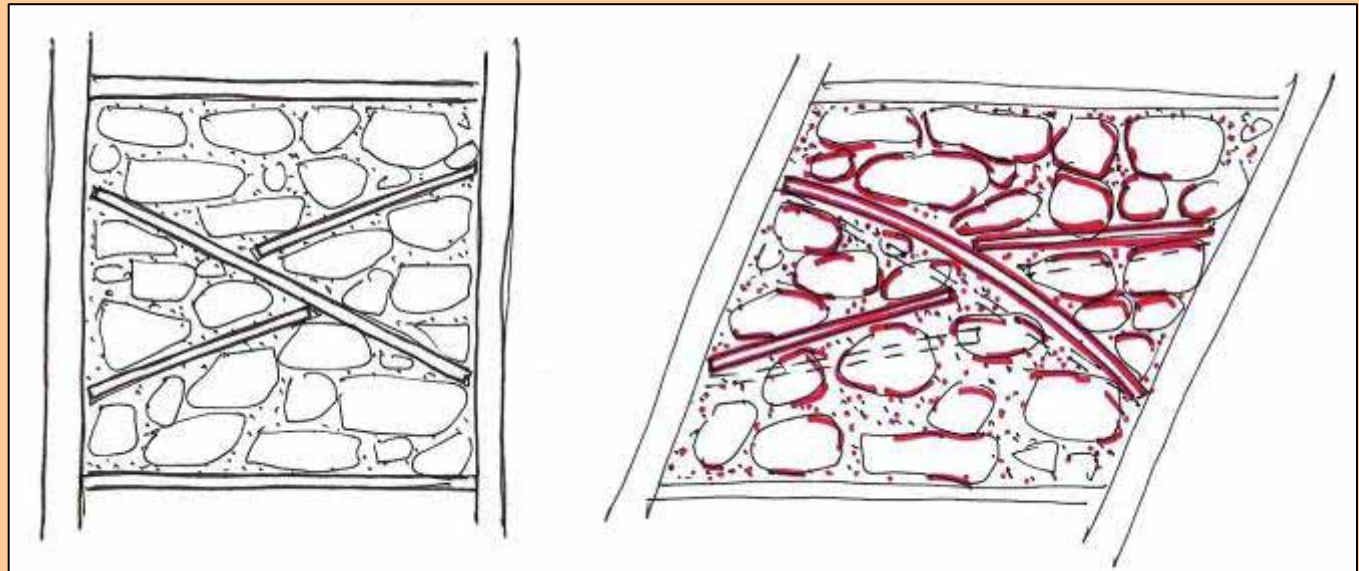

Only a solid frame can contain the energy

- An earthquake will put the frame under great stress.

Take care to make:

- Good joints
- Good protection from water

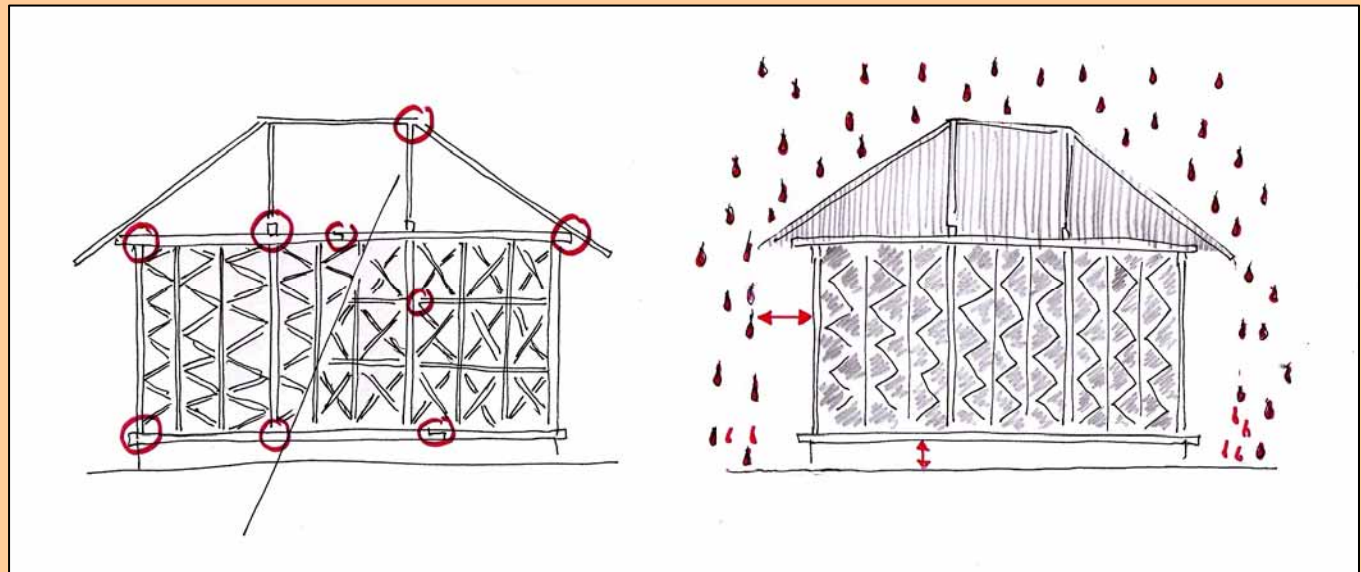

- All joints must be executed with great care.
- The quality of the joints will save you house, and your life.

Solid frame = well done joints

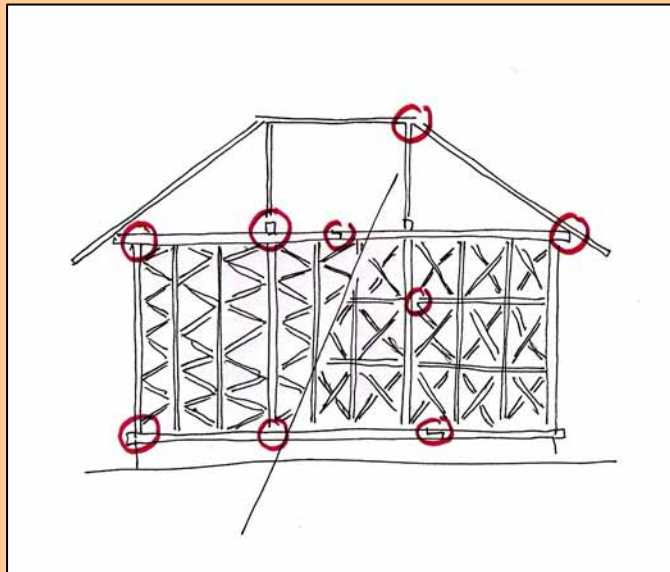

- Timber must be in a good state.
- Timber must be protected from water:
 - Rain
 - Humidity from the ground.

Solid frame = well protected

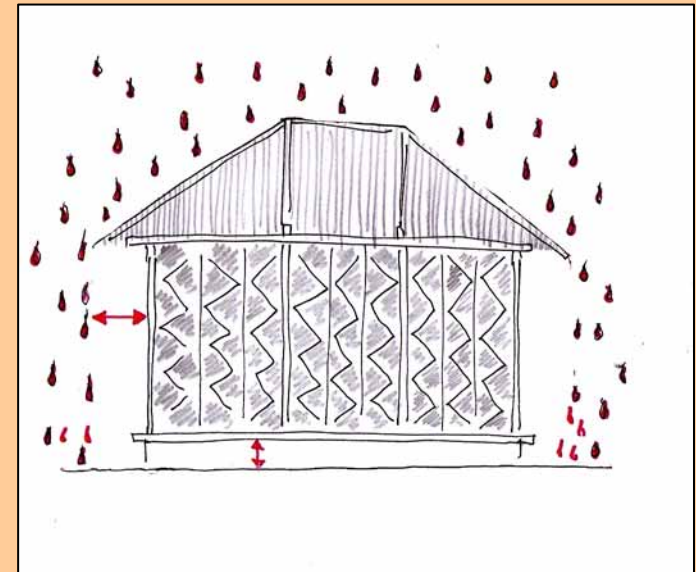



A Dhajji wall is strong because:

- The small panels distribute the earthquake energy evenly.
- The friction between all the small elements and their in-fills breaks down the energy.
- There may be a lot of small cracks which are not dangerous.
- But large destructive cracks become very rare.



But, ... a Dhajji wall is only strong if:

- ALL joints are well executed.
- Timber is well protected from water.
- The infills are done properly.

- This is not a dhajji wall !!!

Why?



- *These panels are too big.*

They can fall out in one single piece.



- *The panels are too rigid.*

There is no friction between the elements which breaks down the energy.



- This too is not a dhajji wall.

Why?



- *The panels are too big.*

They can fall out in one single piece.





2. Foundations

- Prepare a good foundation with stone and cement mortar.



- Place anchor bolts into concrete, into the lower part of the foundation.
- Anchors can be prepared with a plate or a hook.

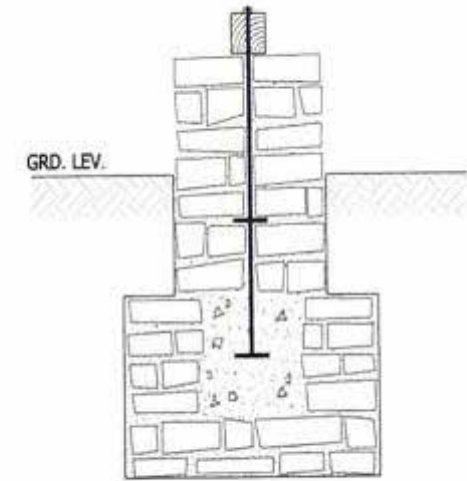
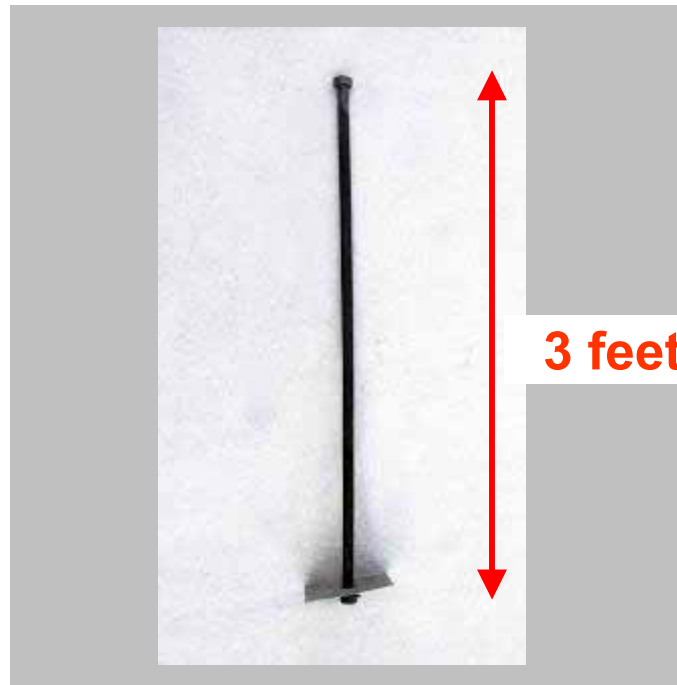

ROD WITH PLATES CAST IN CC ANCHOR AT FOUNDATION LEVEL

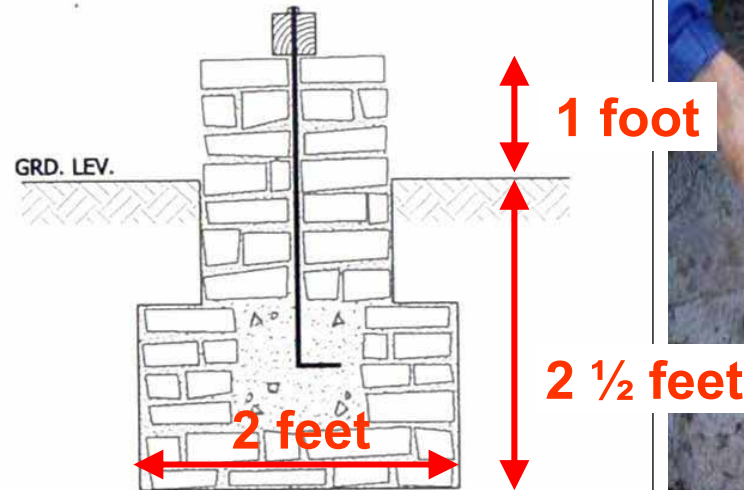

J ROD CAST IN CC ANCHOR PAD AT FOUNDATION LEVEL

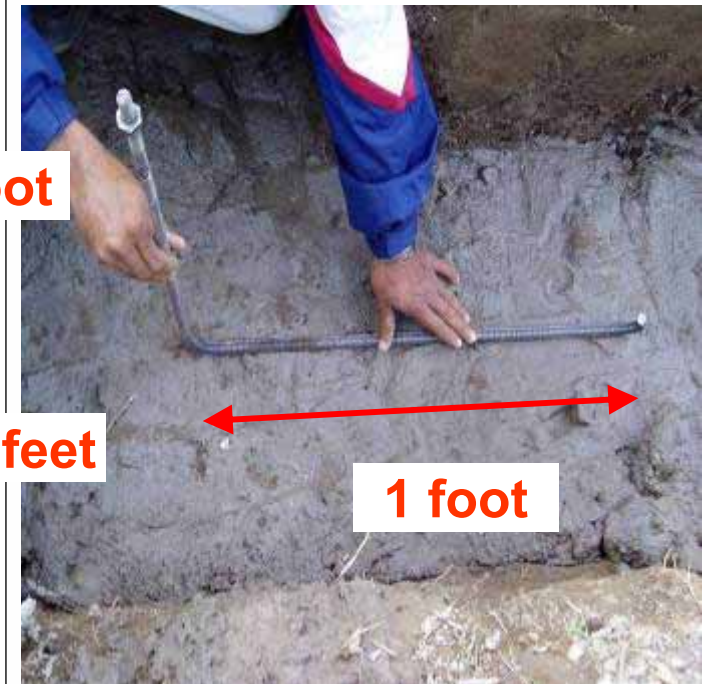

- Distance between anchor bolts about 6 feet.
- Diameter anchor bolt $\frac{1}{2}$ inch.

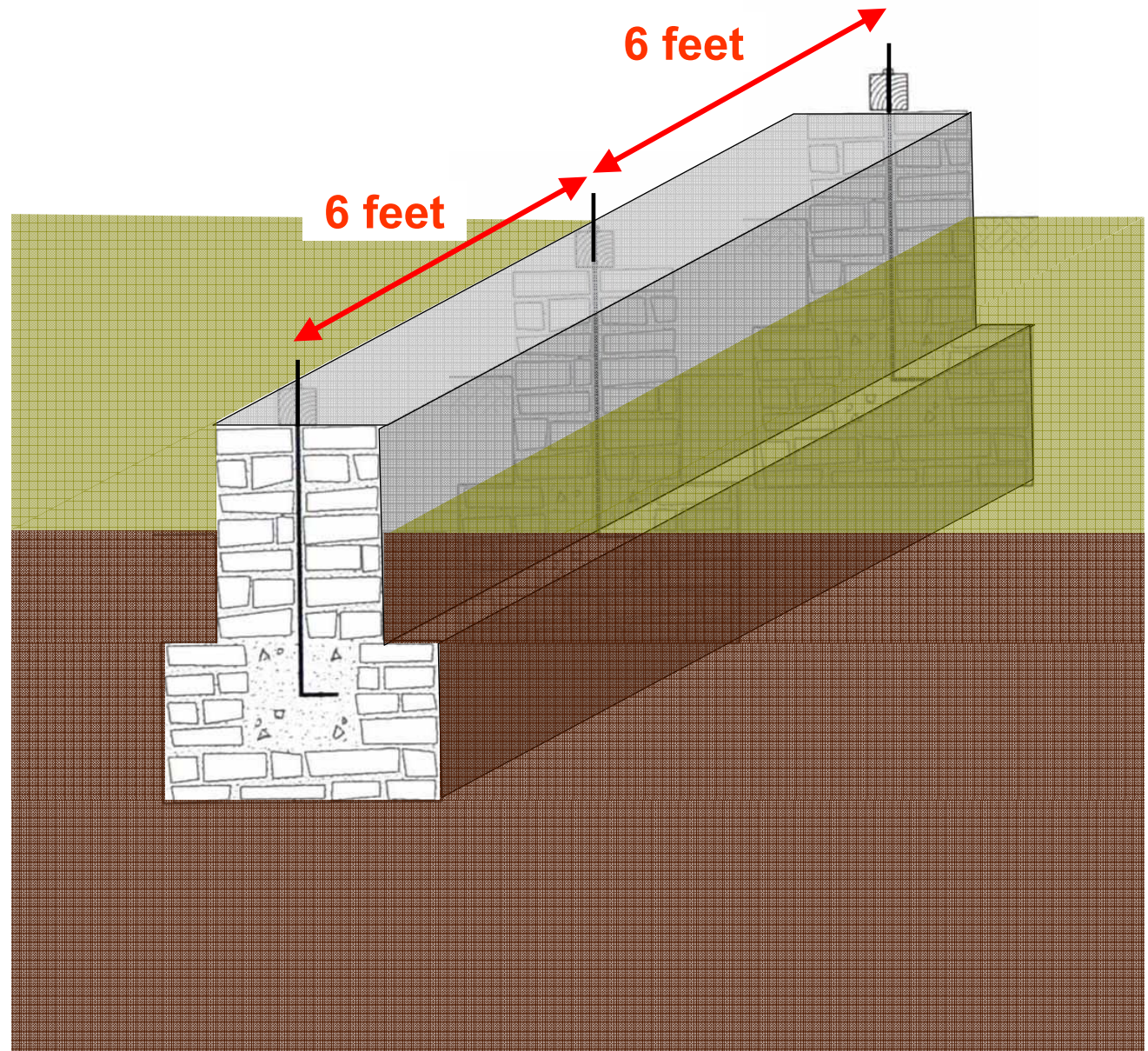

- Top of the foundation should be in stone.



- Top of the foundation should be in stone.
- Avoid a concrete finish, as the water will remain under the dasa.



- Top of the foundation should be in stone.
- Avoid a concrete finish, as the water will remain under the dasa.
- This foundation is not enough solid.



- Foundations shouldn't come out of the ground that much.



- Foundations shouldn't come out of the ground that much.
- They become weak, particularly when made in dry stone.



Best: 1 foot only



3. Dasa (plinth beam)

- Anchoring the Dasa to the foundation
- Protecting the Dasa against water and insects

- **Minimum size of dasa: 4x4 inch**
- Fix the Dasa with the anchors...
- (Don't forget to add a solid washer).

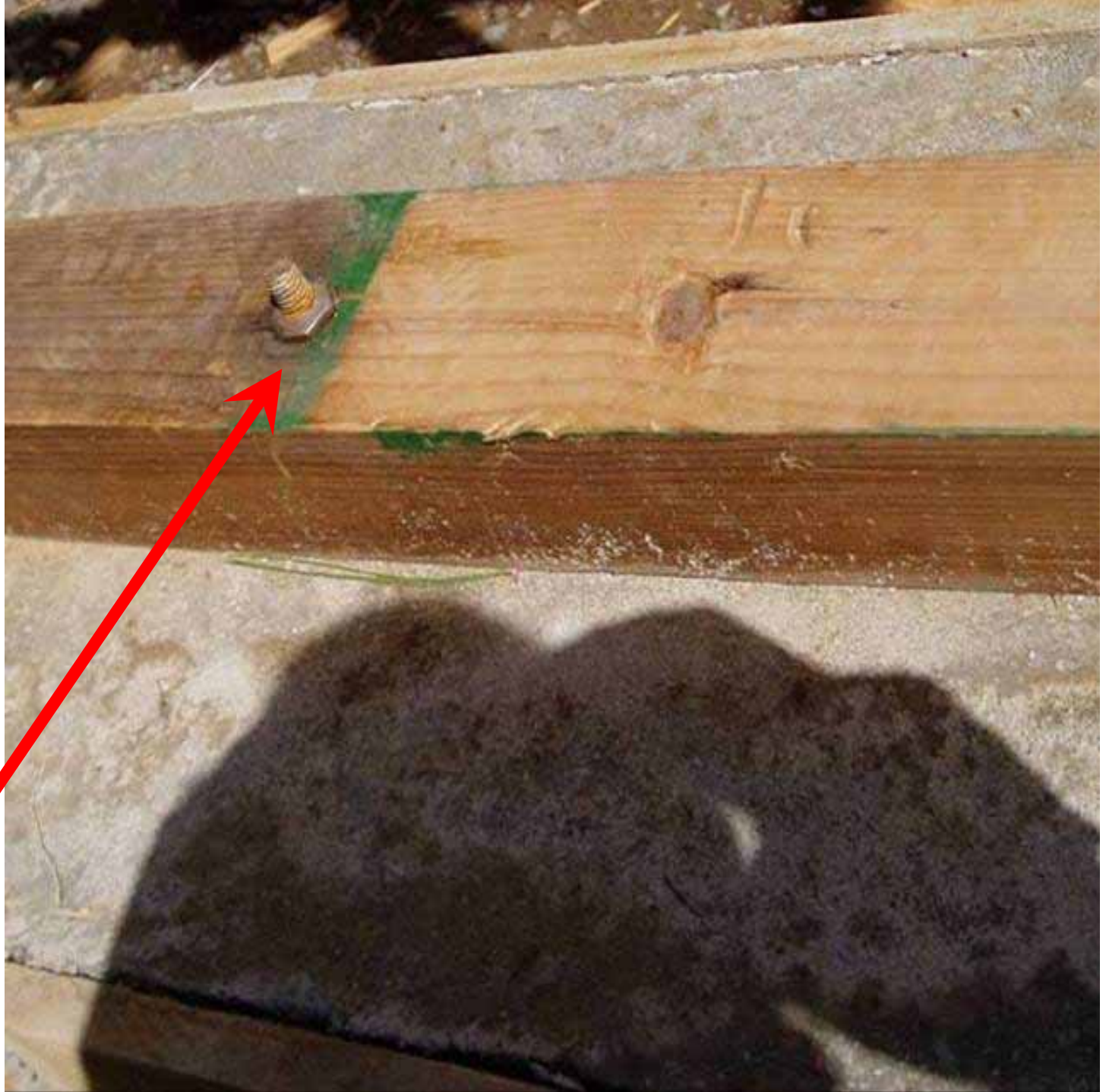

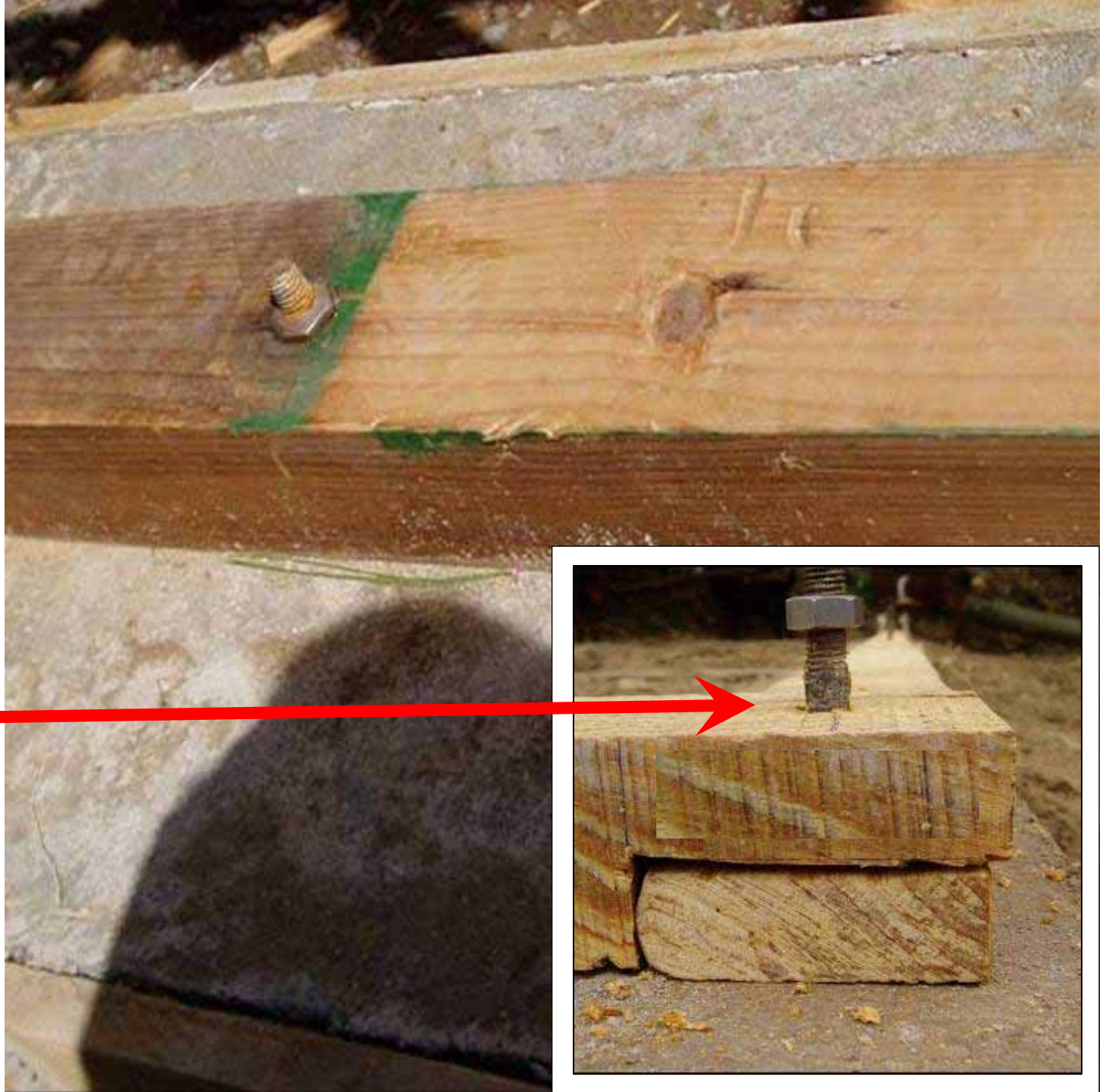

- ... but preferably not in the corners.
- (AGAIN, don't forget to add a solid washer).

- Bad anchoring of the Dasa with loose straps.
- Bolts or re-bars are better than straps to anchor the Dasa.



- Don't place the posts directly on the foundation, without a Dasa.



- Use the best wood for the Dasa.
- Protect the Dasa with old engine oil.
- Apply oil **before** placing, including the lower side.



- Protect the Dasa against water.
- Water from the roof will fall on the foundation and under the Dasa.

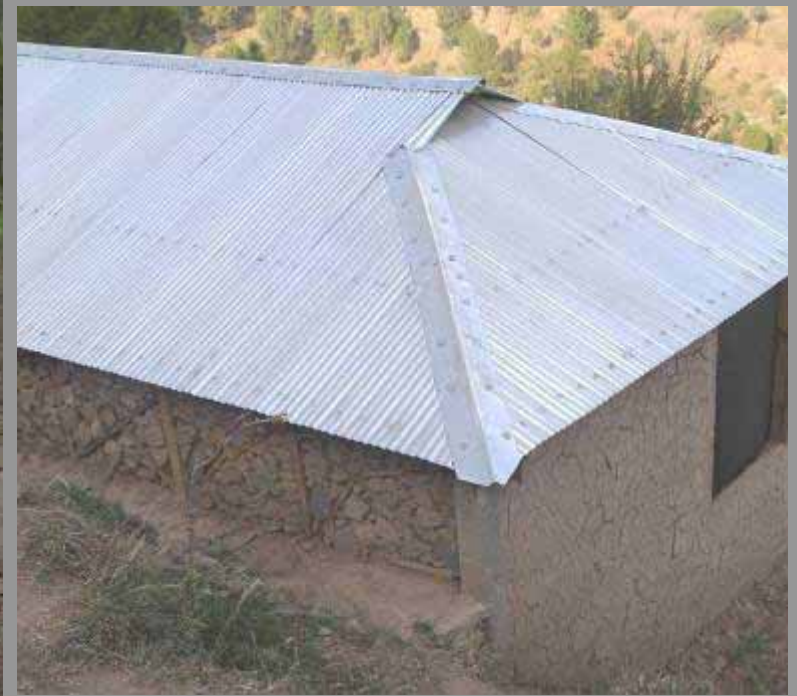



- These are good channels behind the house to keep the water away.

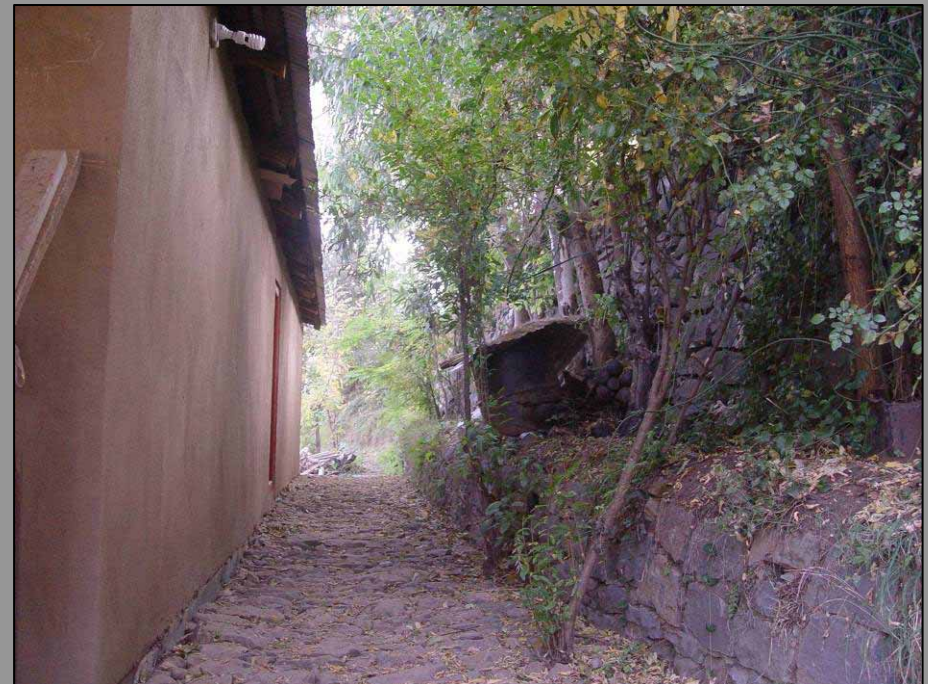

- These are good channels behind the house to keep the water away.



- Foundation does not come 1 foot out of the ground.
- Dasa is in contact with the soil.
- Humidity will creep into the Dasa and ruin it.





4. The frame structure

- A well done frame structure.
- But this is not for dhajji construction.
- The panels to receive the infills are too big.



...and:

- No foundation: the dasa on the ground will rot away very quickly.



- A typical Dhajji frame structure



- A typical Dhajji frame structure
- Unfortunately the Dasa is missing!



- This subdivision is correct.
- Main posts should be 4 to 6 feet apart.
- With this spacing, the main posts must be 4"x 4"



Max. 2 ft

- With no main posts (except the corners), the vertical boards can be 2"x 4".
- But they must be maximum 2 ft apart.



- This is not a frame structure.
- Why?



- *No Dasa (foot plate or plinth beam)*
- *No bracings*
- *No solid joints*





5. Joints

- Dasa extension joints
- Wall joints
- Corner joints

Use a

- **Scarf joint**
- **Lap joint**

to make the
Dasa
longer.

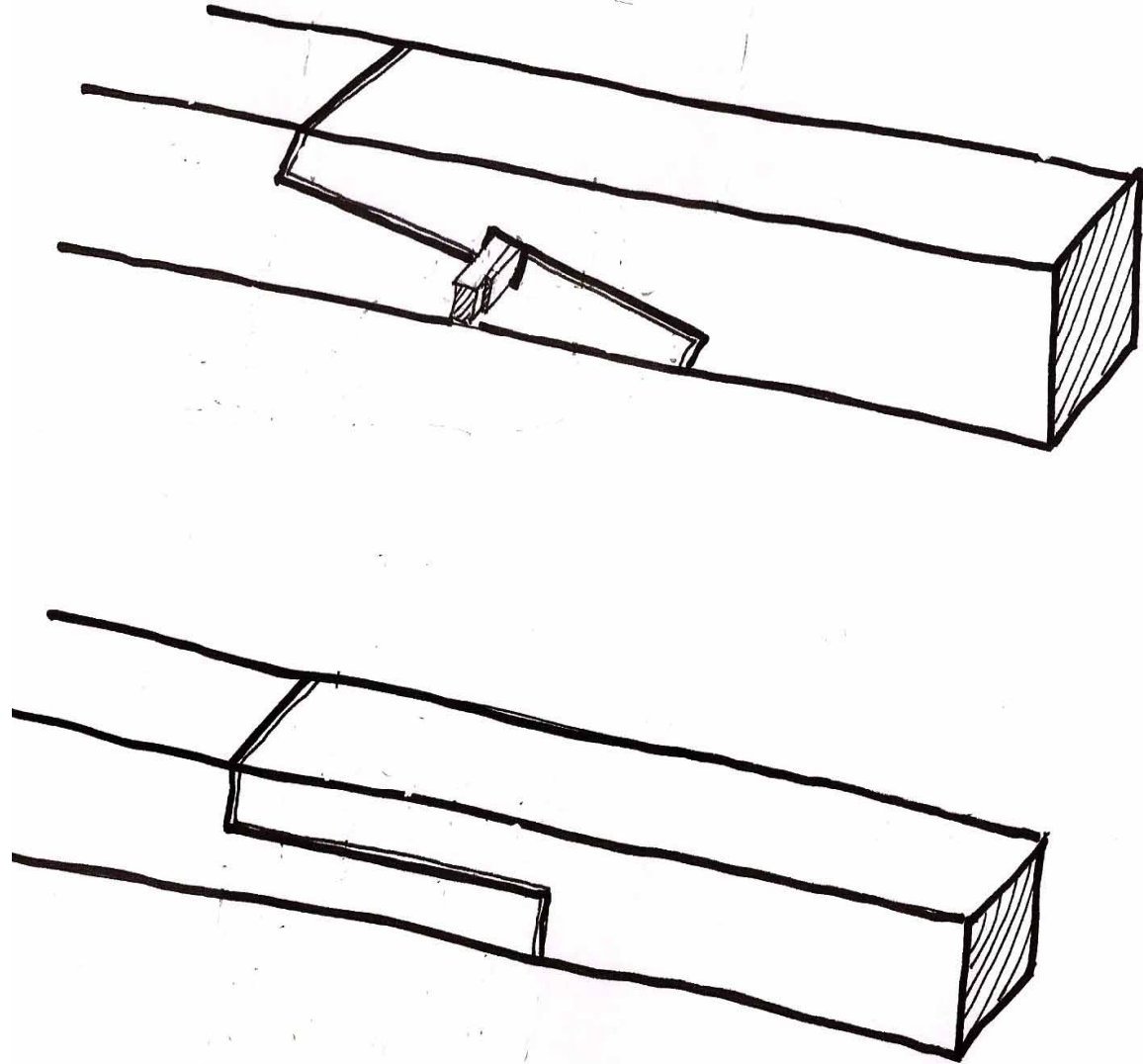

Scarf joint:

- Length: 3 times size of beam (with 4"x4" beam = 1ft).
- Cut as on the drawing.
- Use a hardwood peg, cut into 2 wedges.

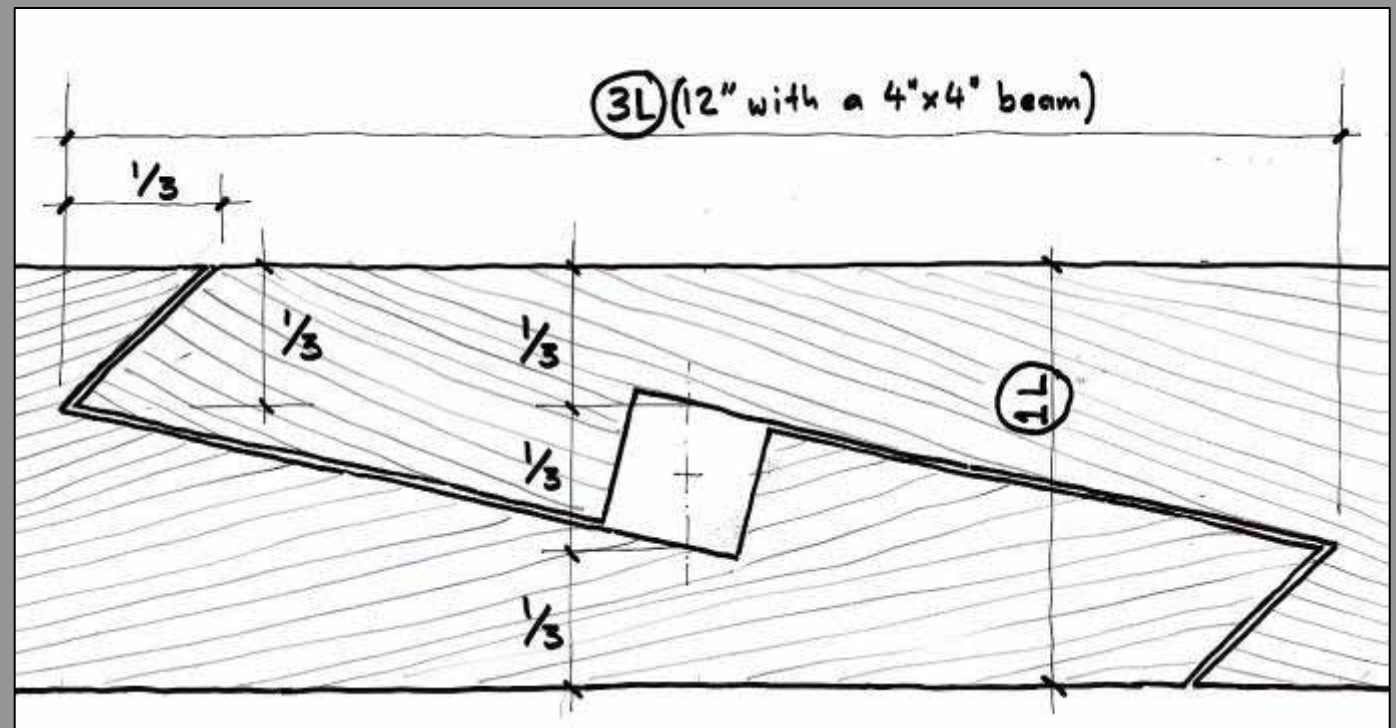
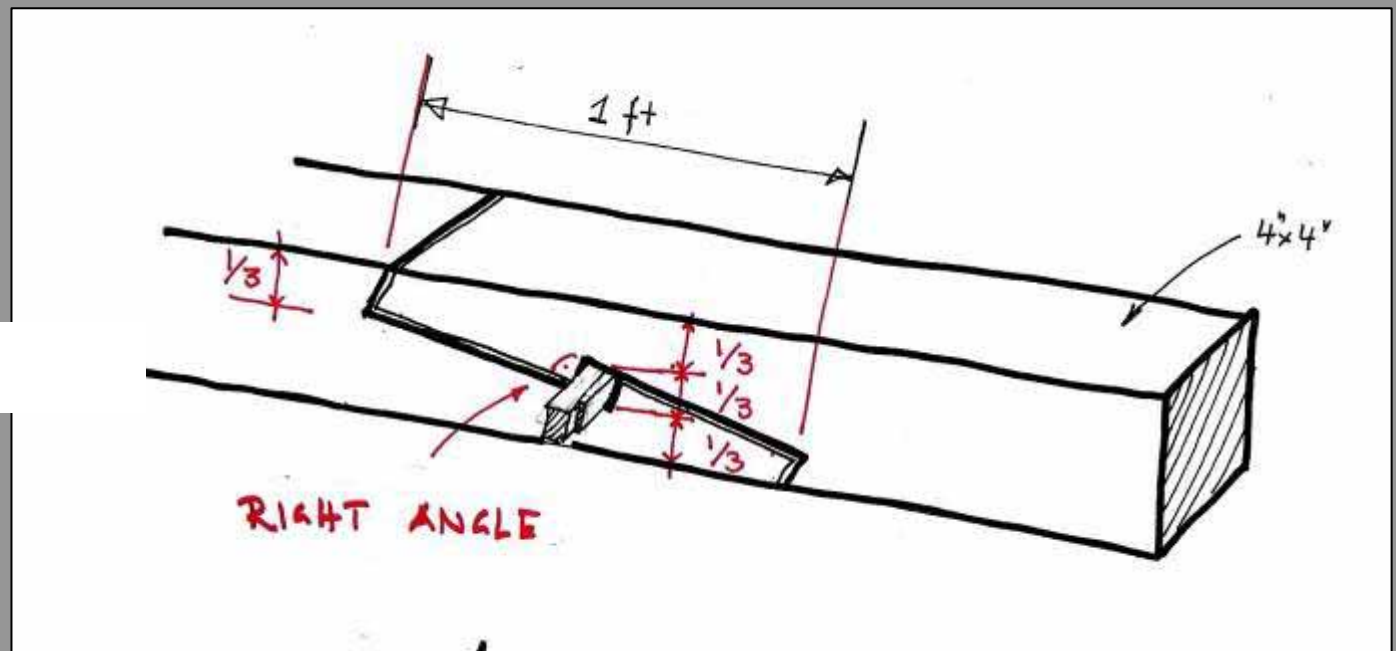

Scarf joint:

- How to make a scarf joint.

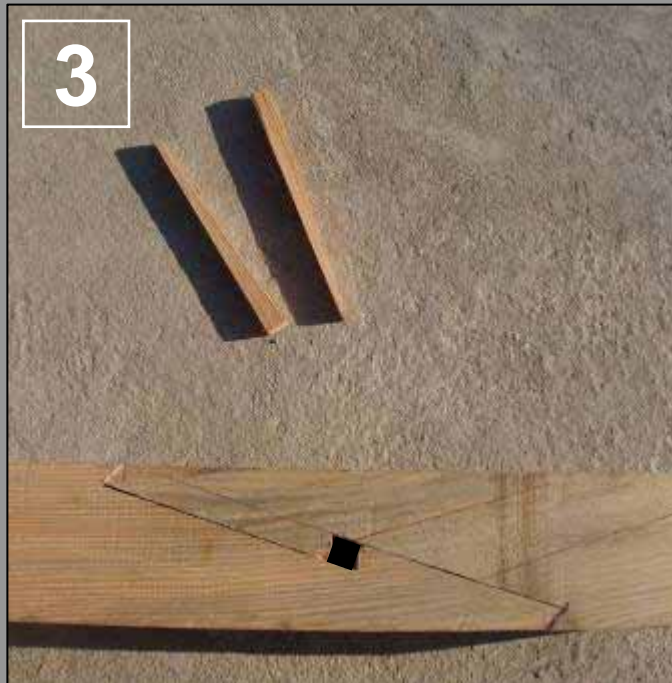
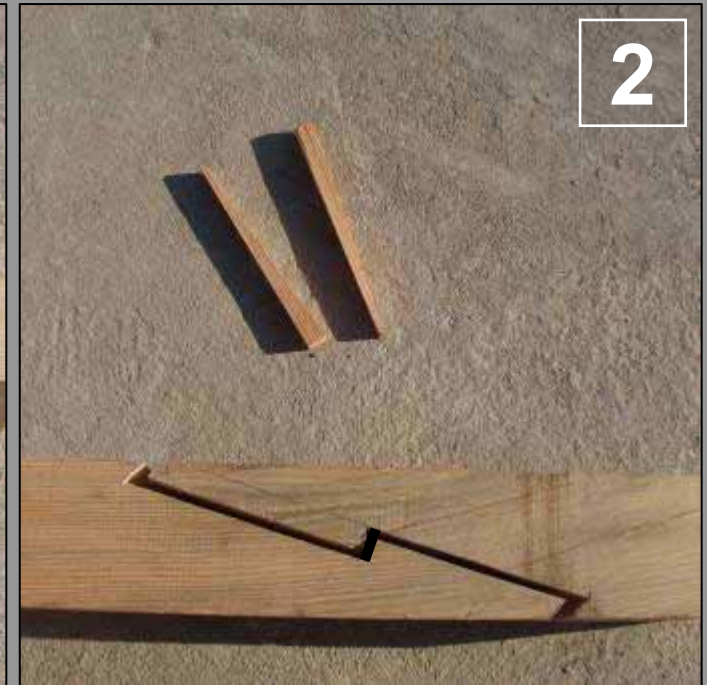
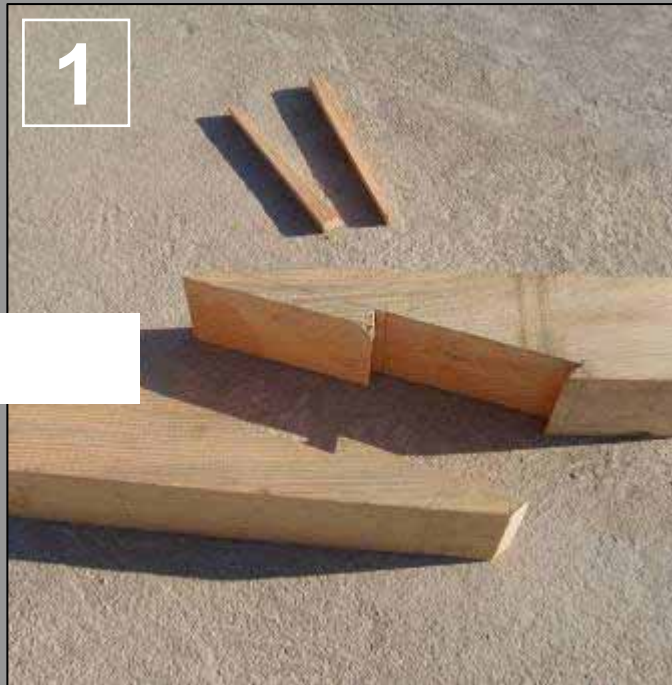

Lap joint:

- Length: 3 times size of beam.
- Connect with 4" nails, 3 from each sides.
- First nail 4" from end of wood.

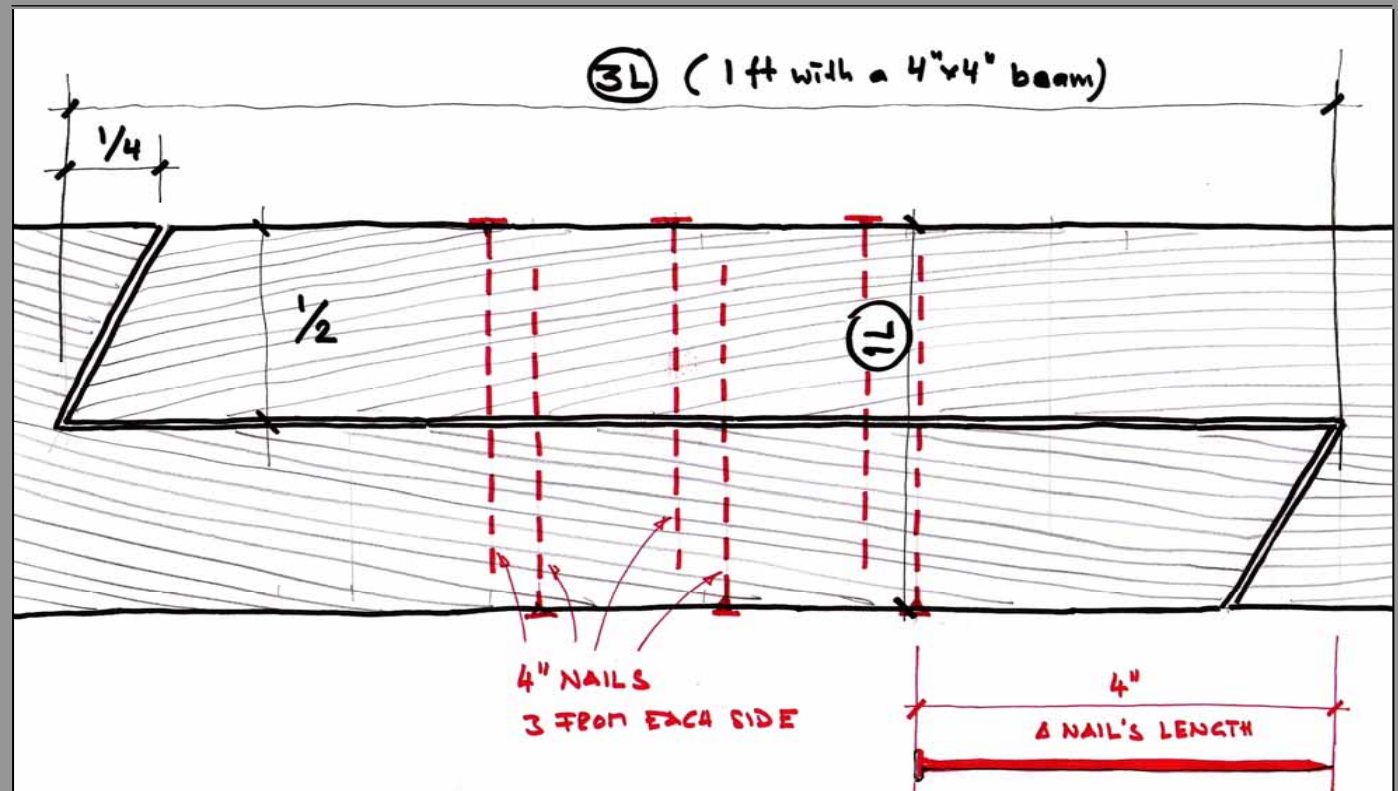
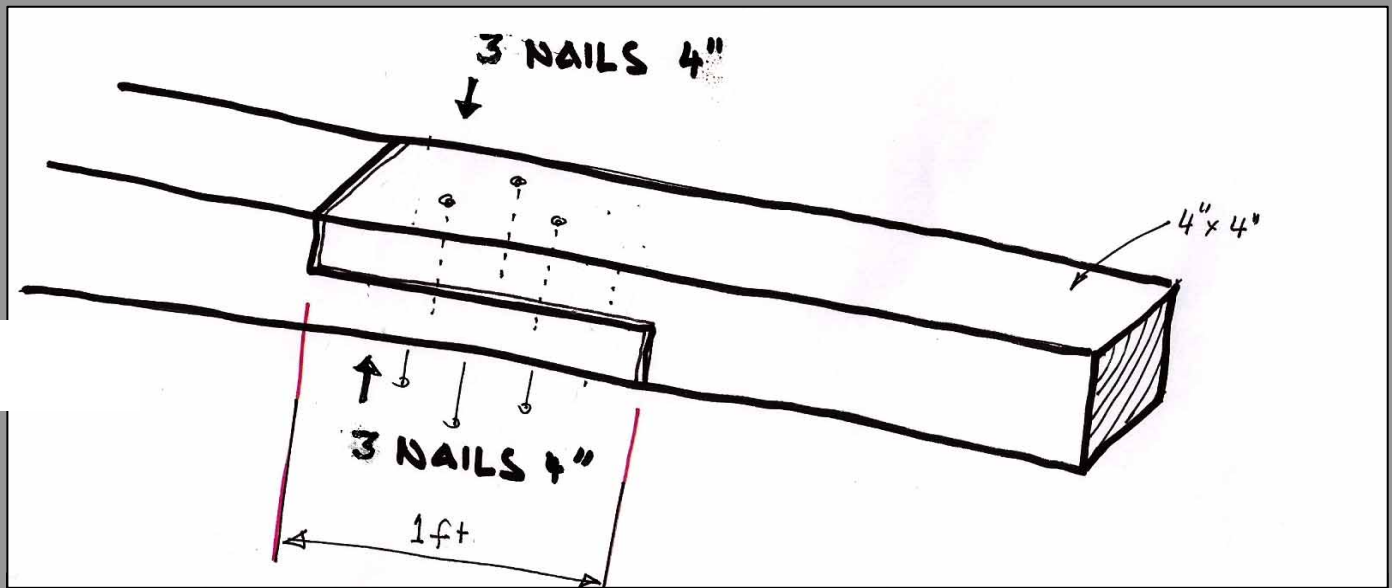

Lap joint:

- A squinted end of the lap improves the joint against torsion.

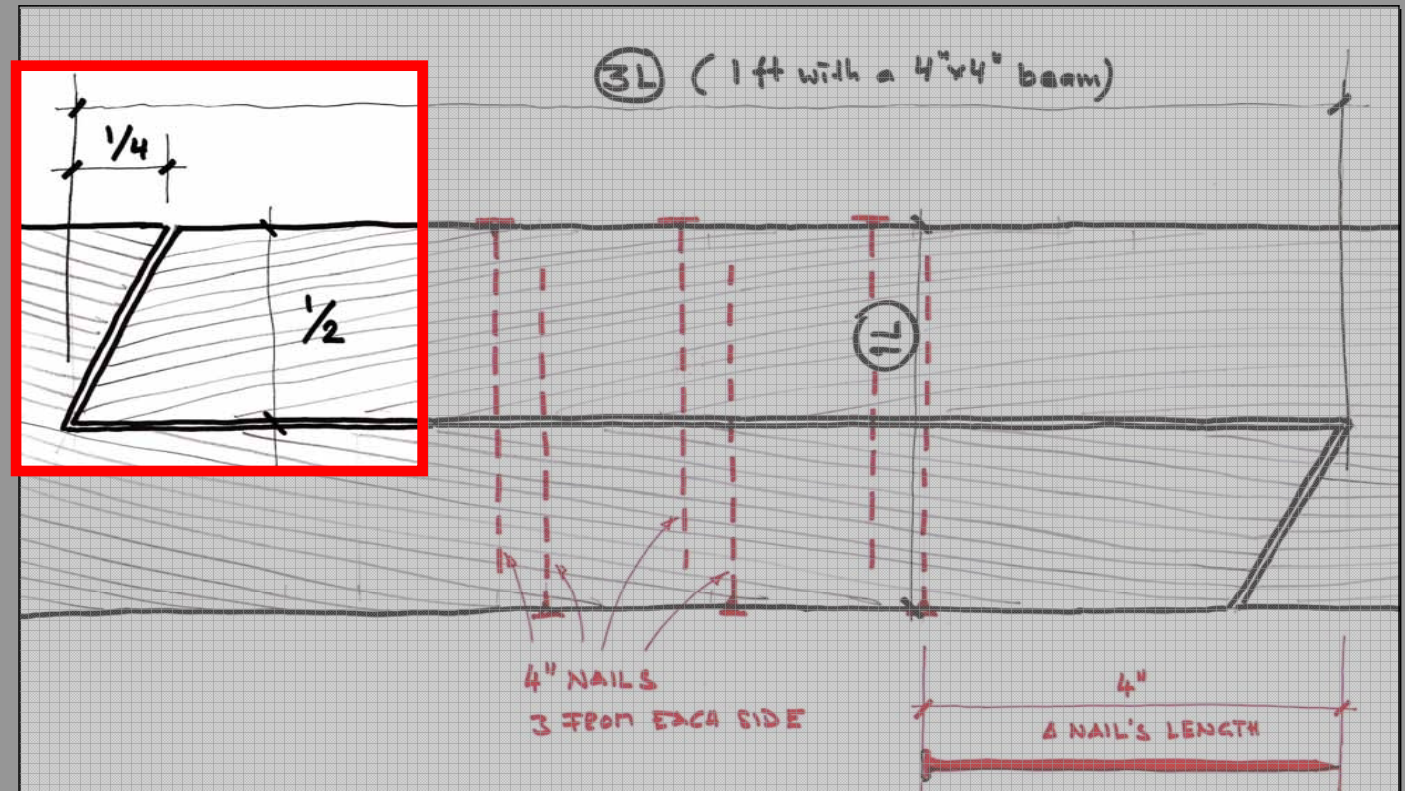
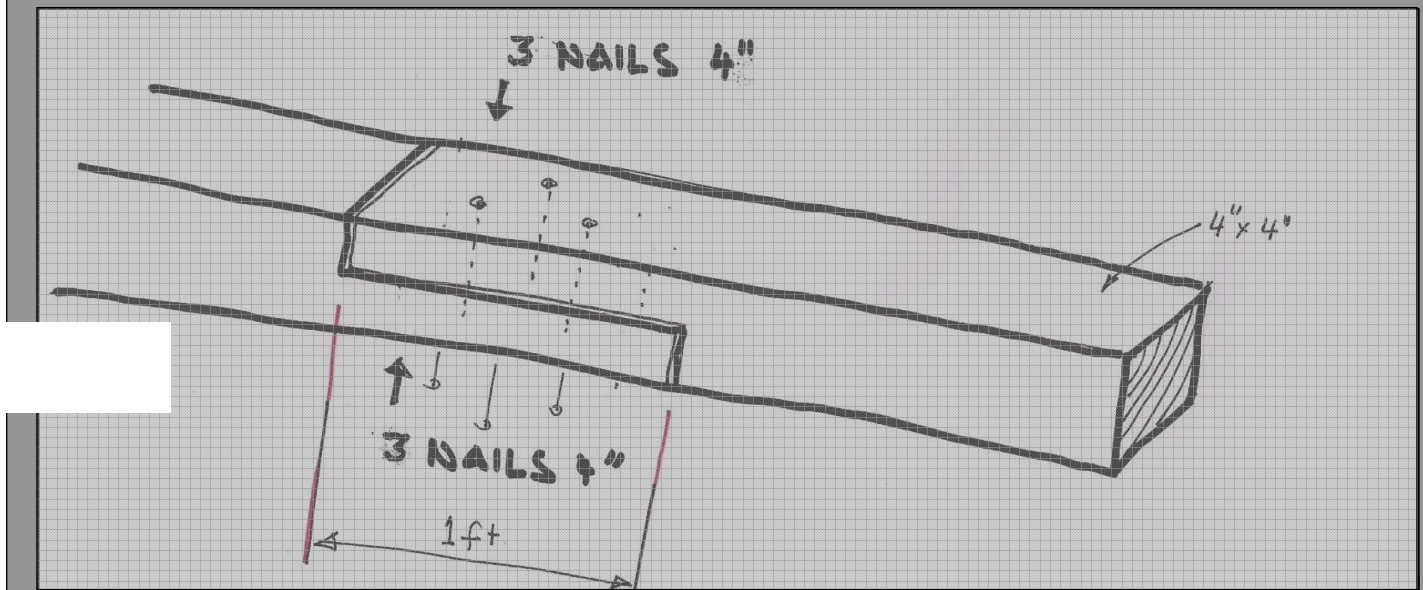

Tenon and mortise:

- To join the posts with the dasa, use tenon and mortise joints.



Tenon and mortise:

- You can add straps...

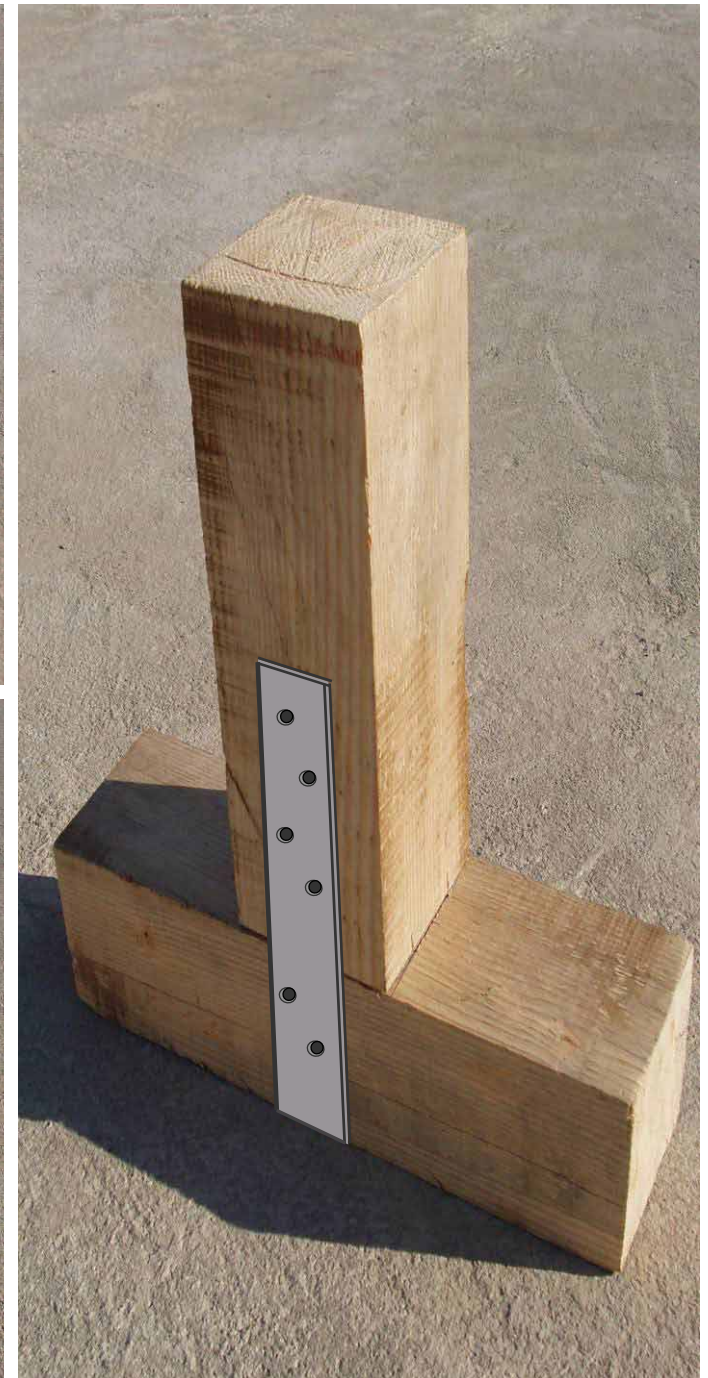

Tenon and mortise:

- You can add straps...
- ... or nails to secure the joint.

(here straps are better than nails).

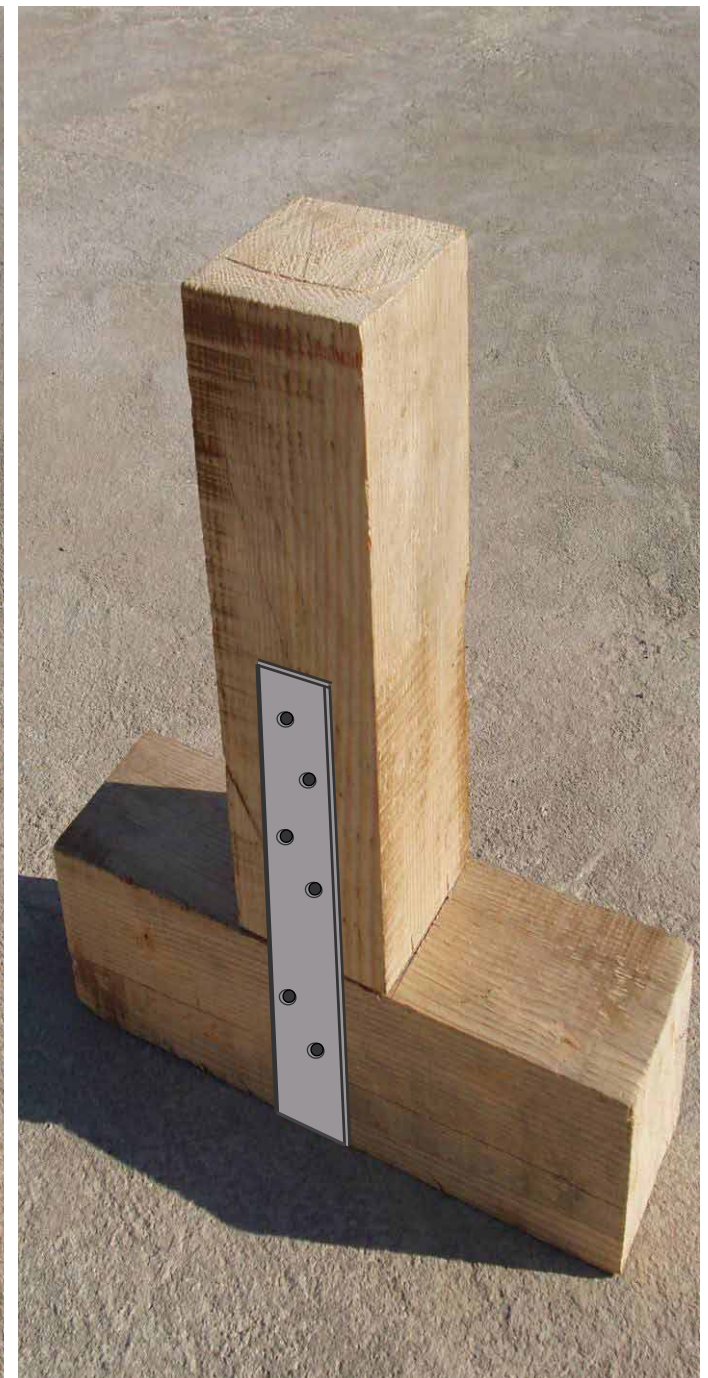
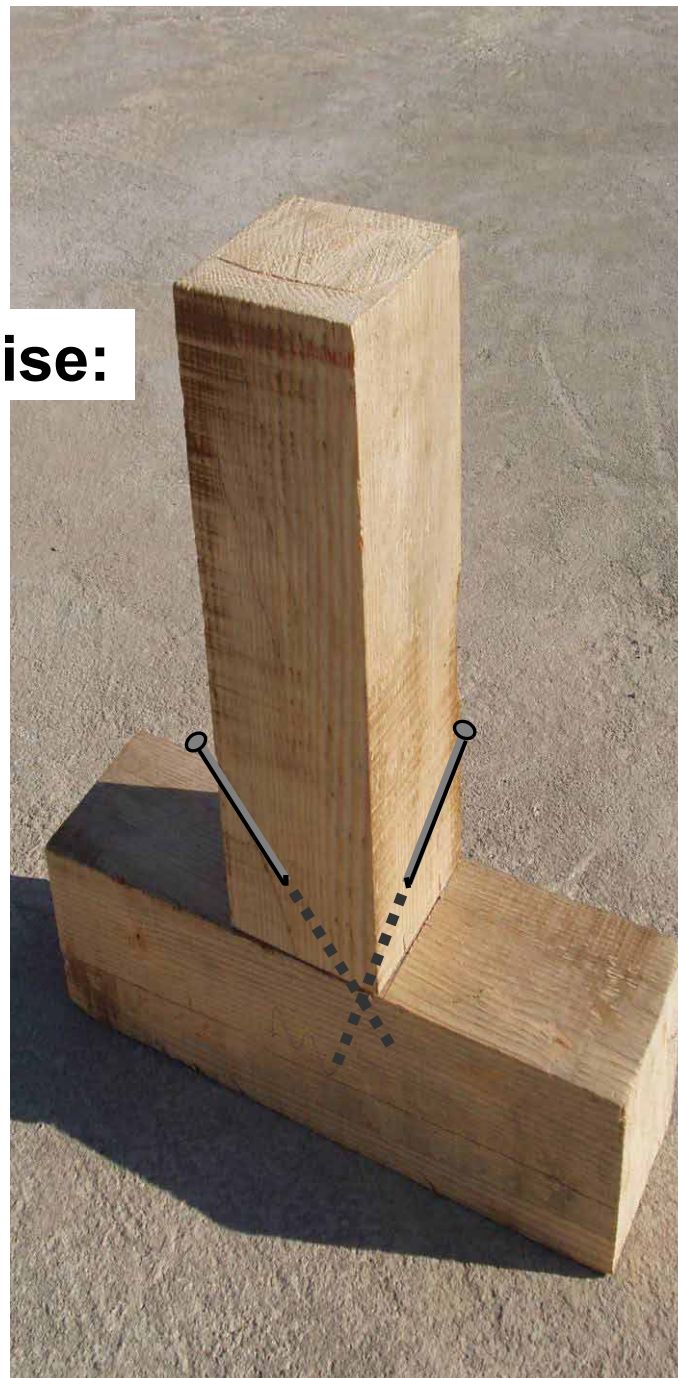

- Wall plate and posts must be well connected, with tenon and mortise joints and long nails (4"– 5") or straps.



- Joints on top of a columns are weak points!

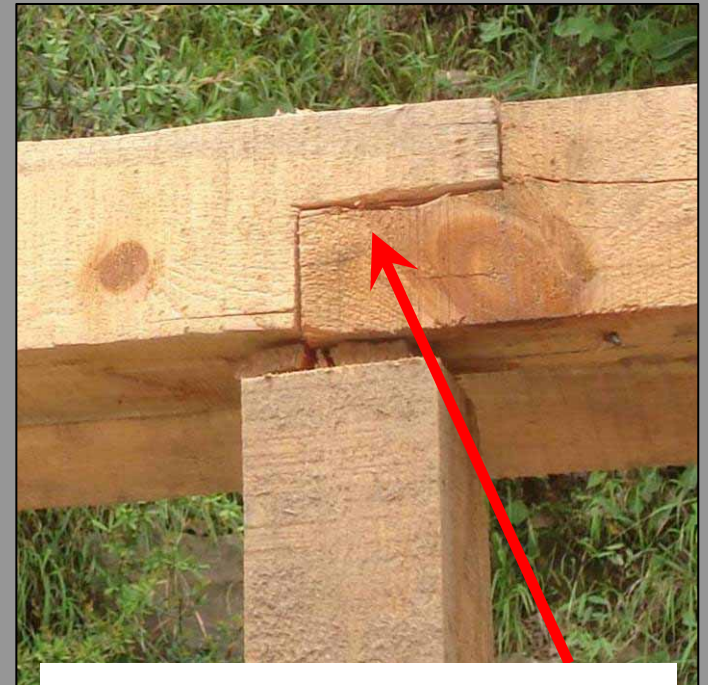

Laps are too short!



- Joints on top of a columns are weak points!

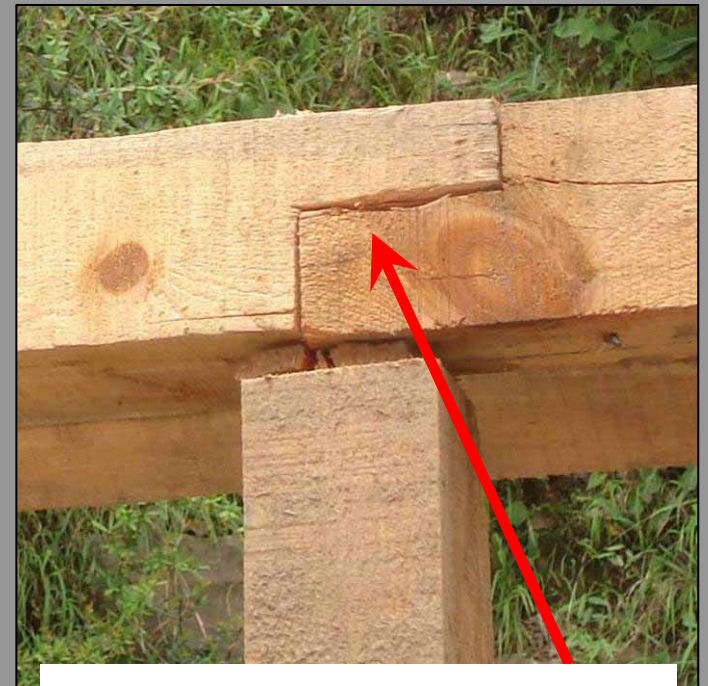

Laps are too short!

- And what is this ???



- If you join beams on top of a column, you **MUST** add a capital.



- Use pegs and tenon and mortise joints to secure the pieces against horizontal shift.

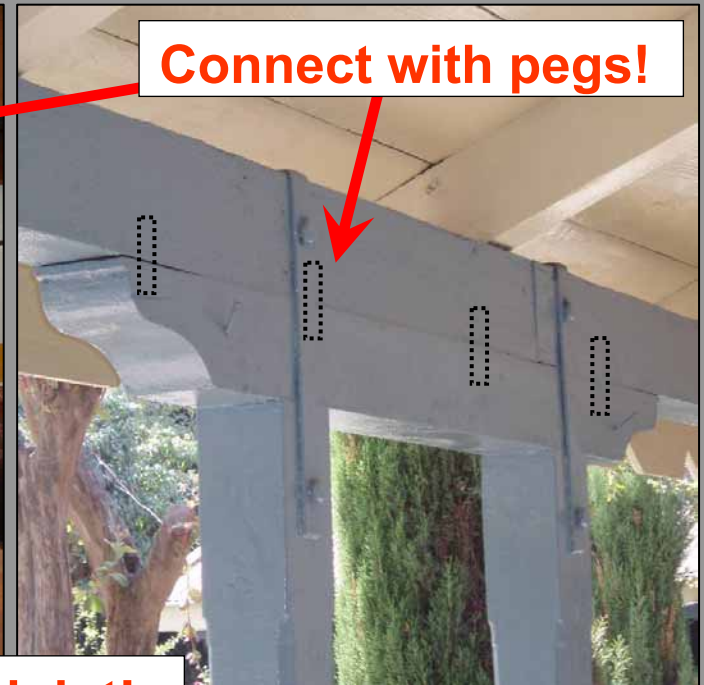
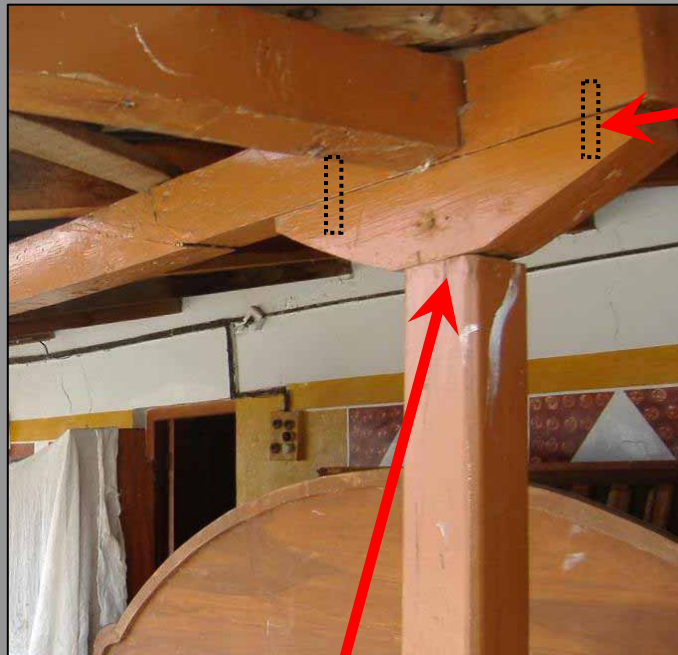

- Add straps to secure the pieces against vertical movement.



- Joint reinforced with a good strap against vertical movement.
- It's better to put the straps on top and bottom of the beam.



- These straps are too weak. Why? (check the nails)



- Instead of straps, you can use pegs or 4" nails from the top.

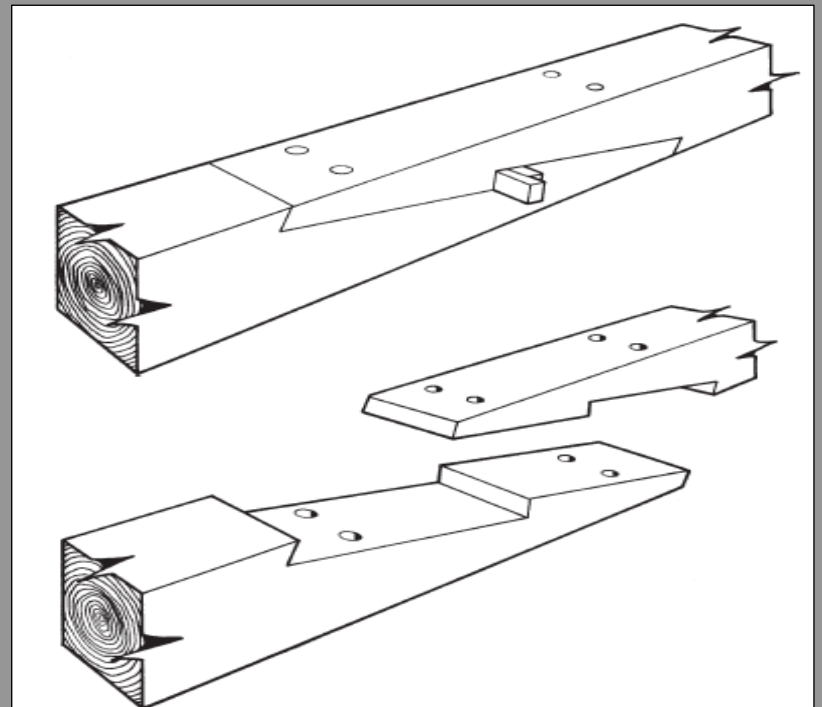

- This connection to hold down the wall plate is useless. The iron bar will stretch open with the slightest movement.



- This L shaped connection is insufficient, as the nails will be pulled out with the slightest movement.

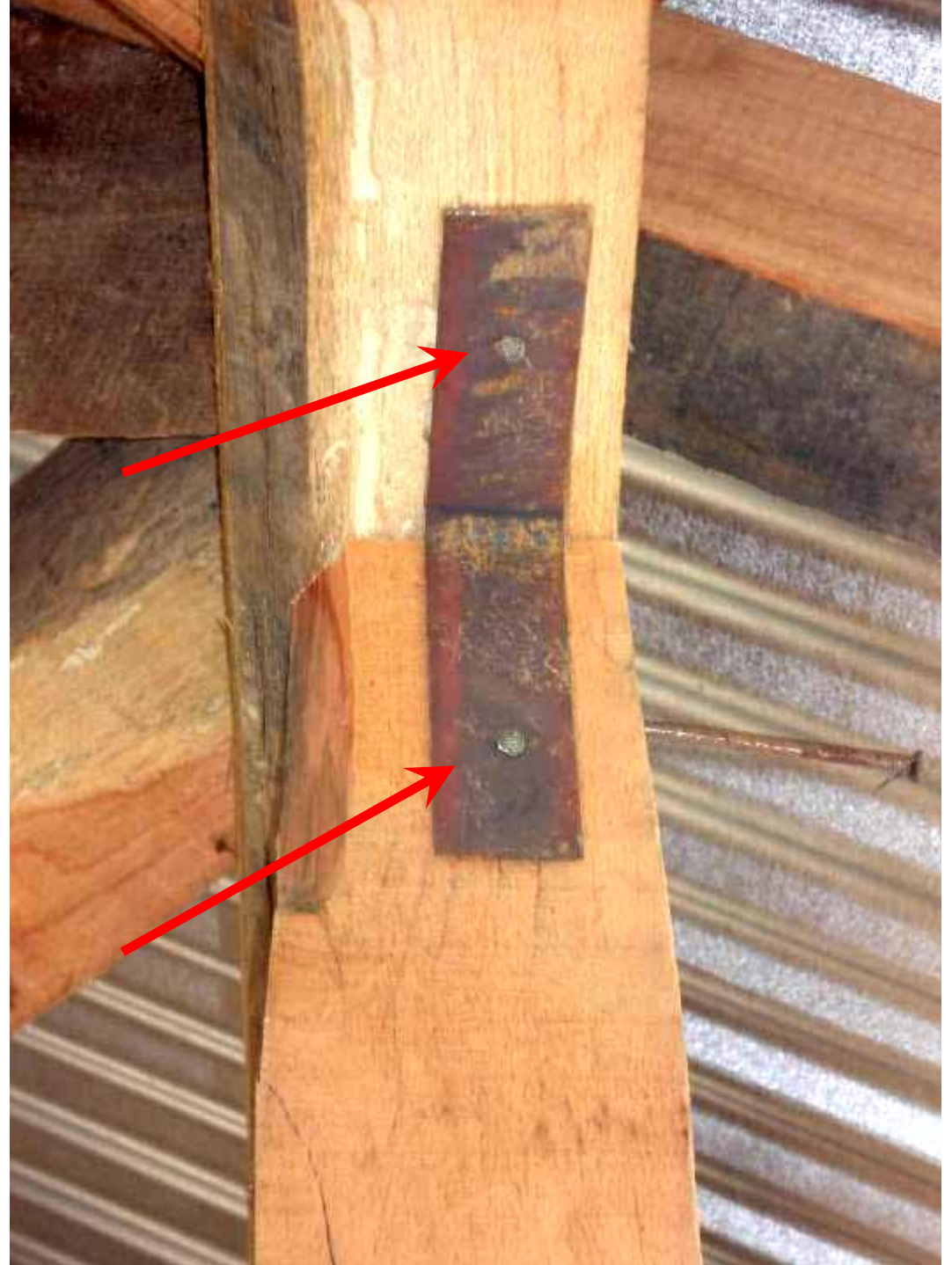

Corner joints

- 3 methods for the dasa-post joint in the corner:

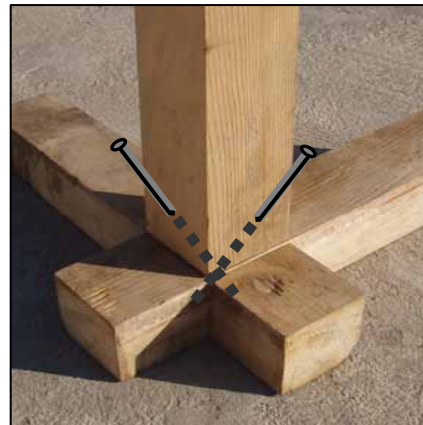
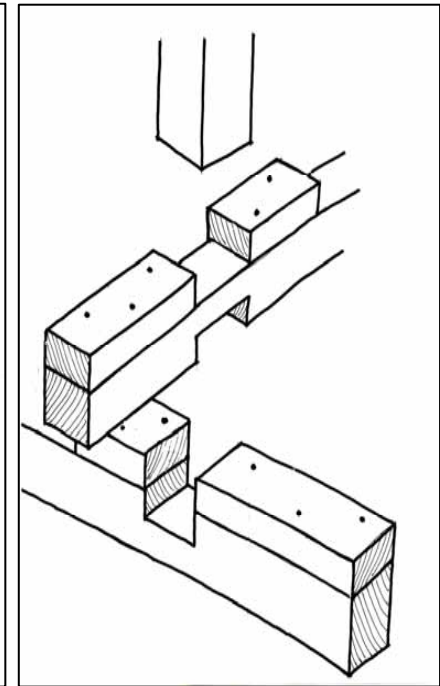
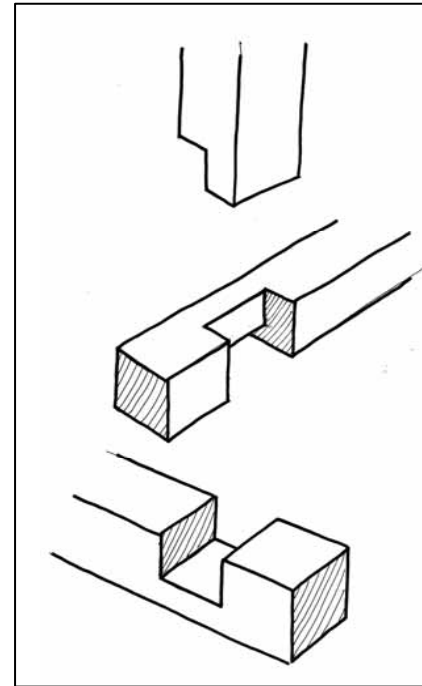
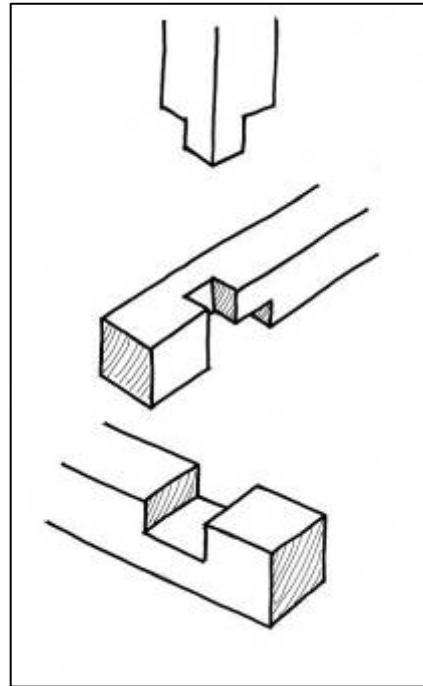

Quarter tenon

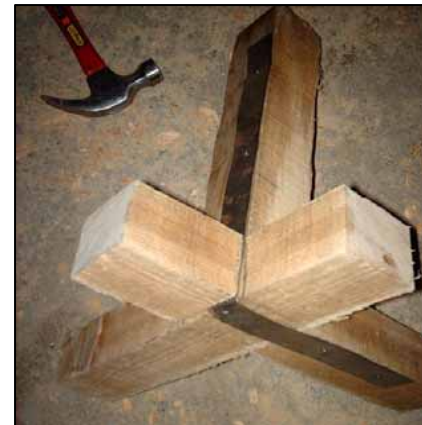

Half tenon

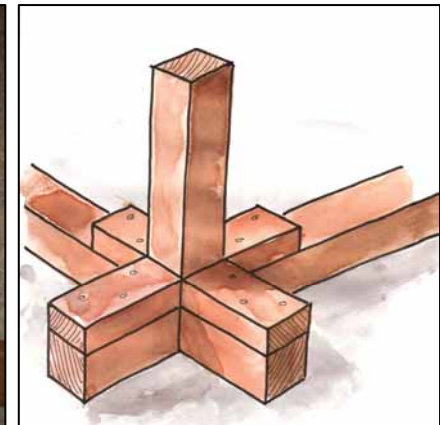

Added blocks

Quarter tenon:

- Overlap the dasa in the corners.
- Then place the posts on the dasa.
- Add 5" nails to secure connection.

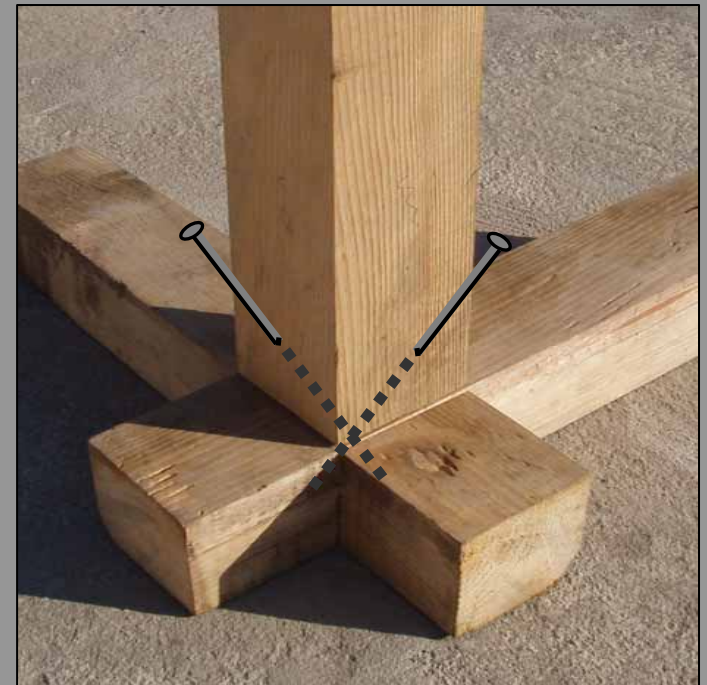

Quarter tenon:

- How to make the quarter tenon corner joint.



Half tenon:

- Leave at least as much wood after the cut-out as the timber is wide.

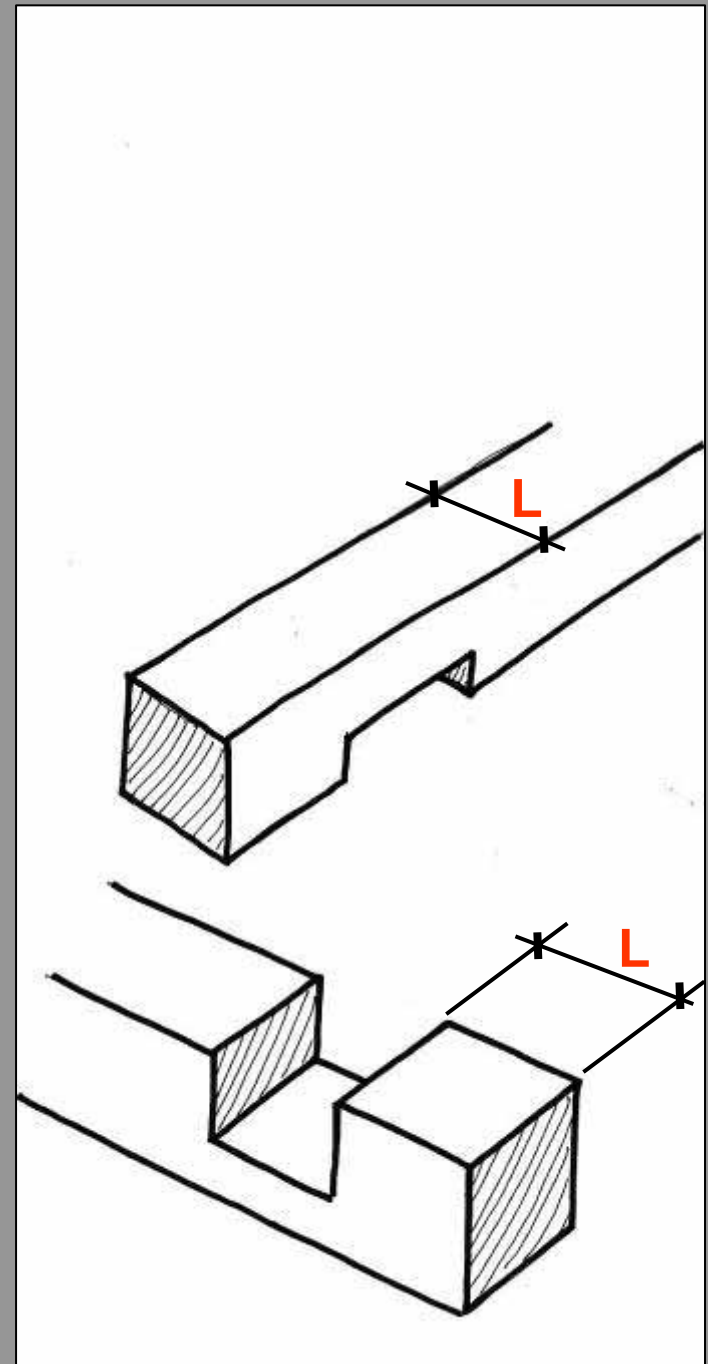

Half tenon:

- Cut first lap $\frac{1}{3}$ deep.
- Cut the lap $\frac{2}{3}$ deep.

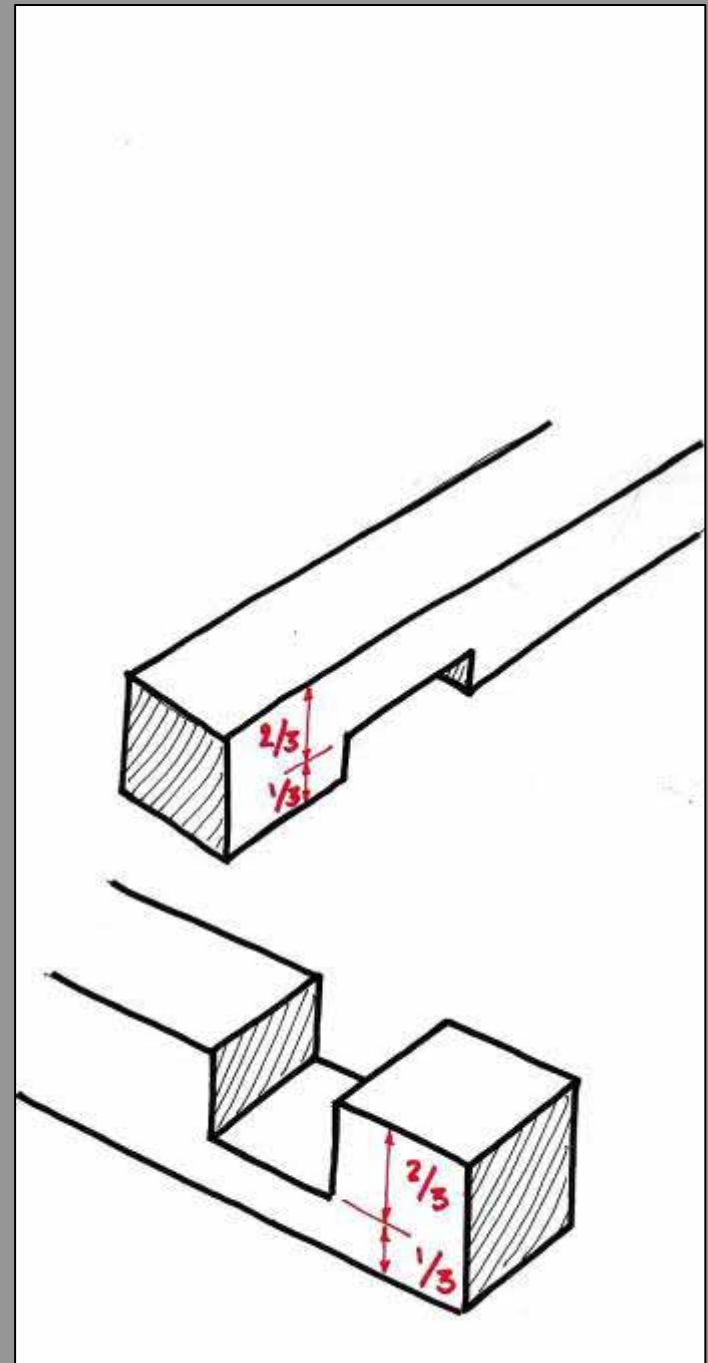

Half tenon:

- Then cut out half of the remaining lap of the top beam.

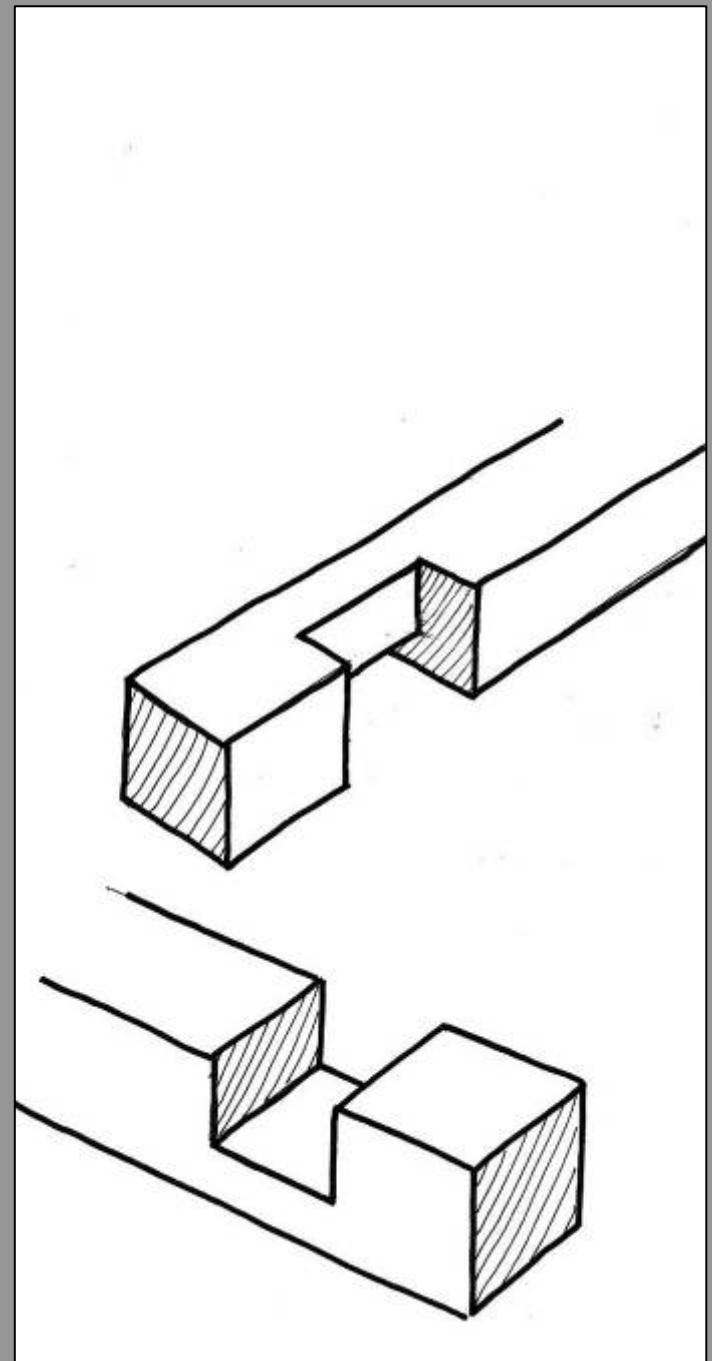

Half tenon:

- Then cut out half of the remaining lap of the top beam.

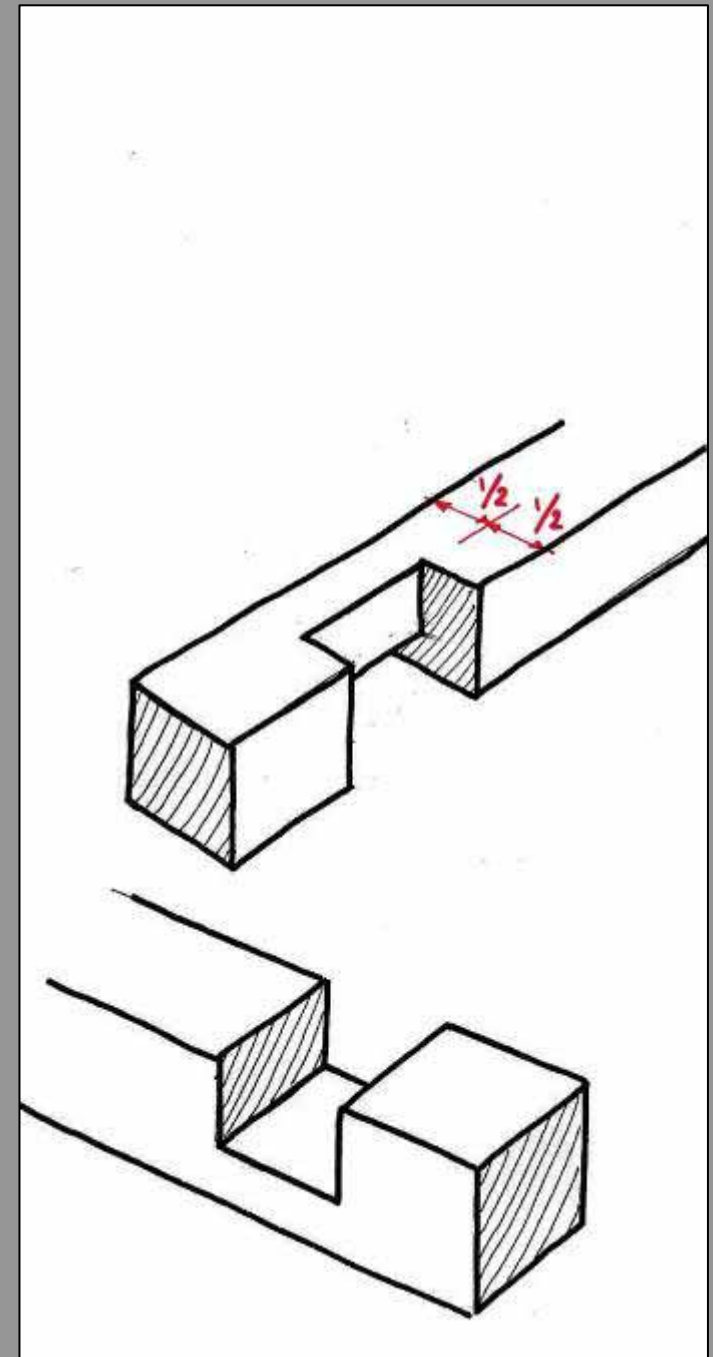

Half tenon:

- Prepare the post by cutting a tenon $\frac{1}{2}$ its width and as high as the remaining part of the dasa lap ($\frac{2}{3}$).

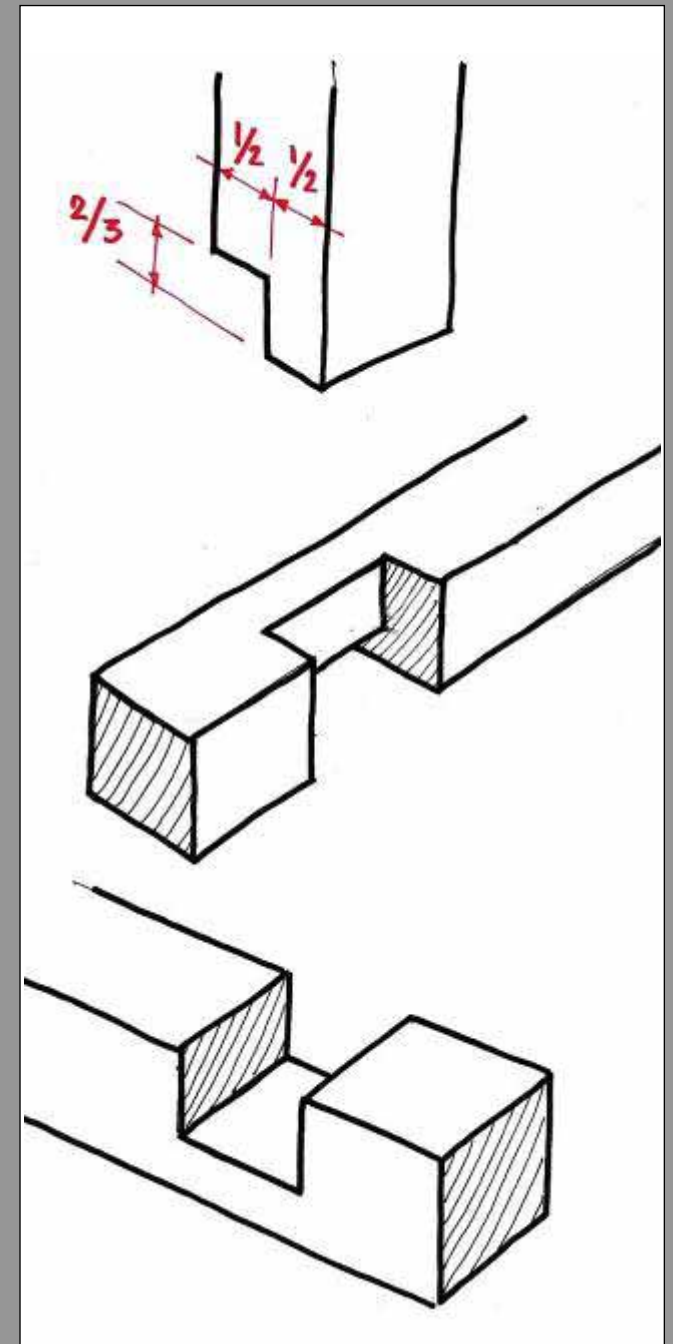

Half tenon:

- Add a strap before you place the dasa on the foundation.
- Bend it through the joint.
- Nail it against the post with 3 nails.

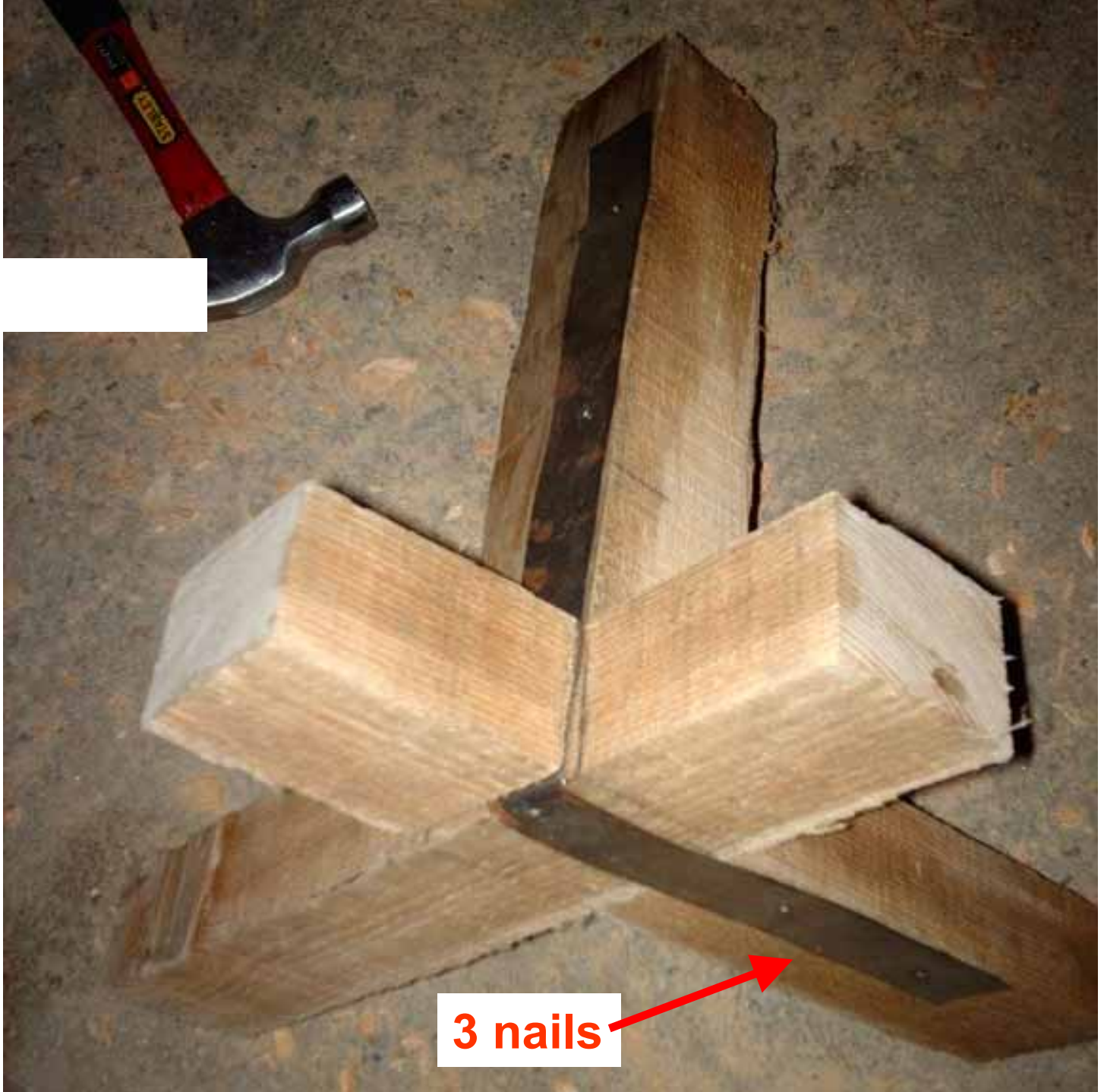

Added blocks:

- Leave one foot of timber after the joint.

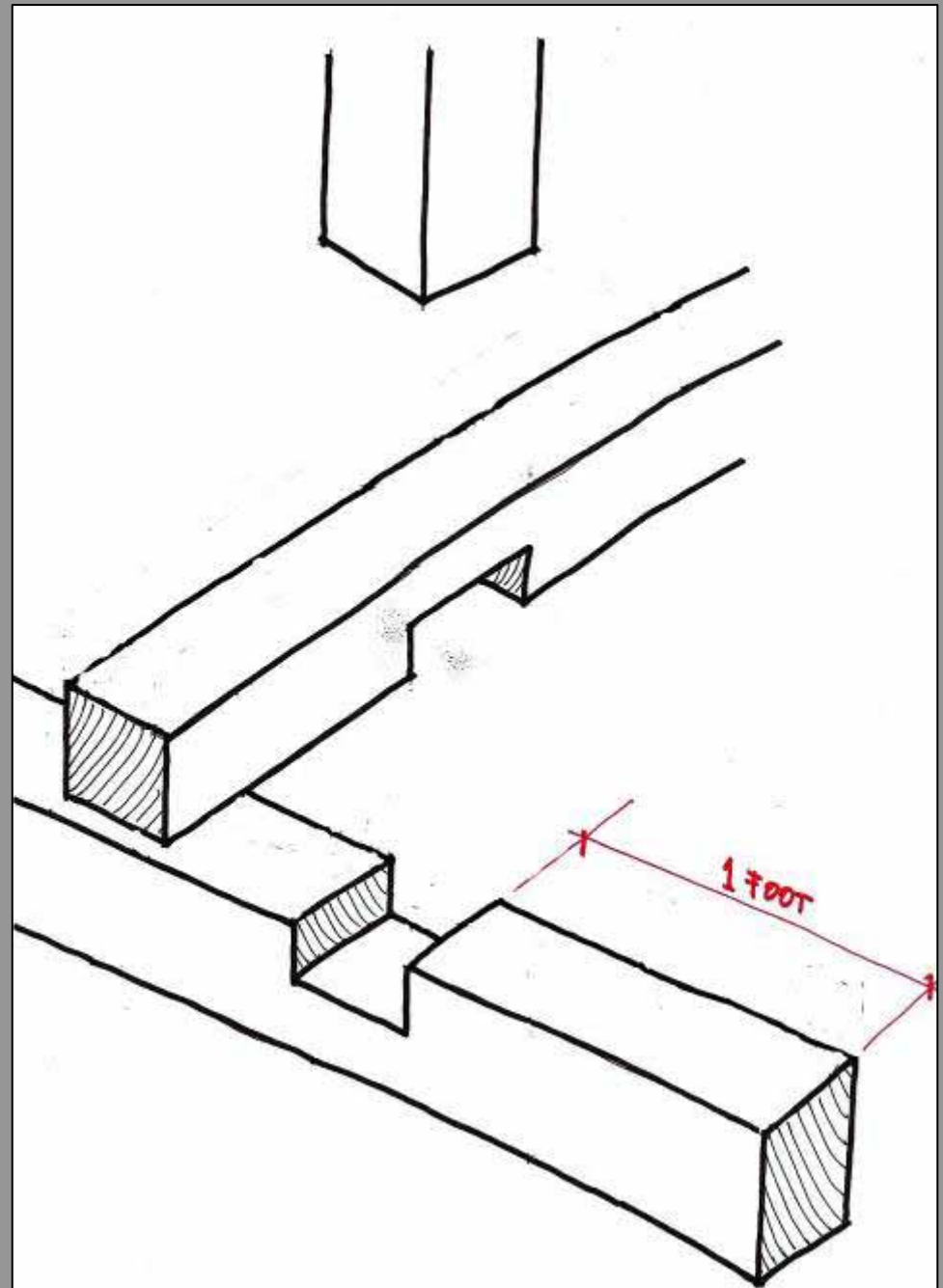

Added blocks:

- Add 2"x4" blocks:

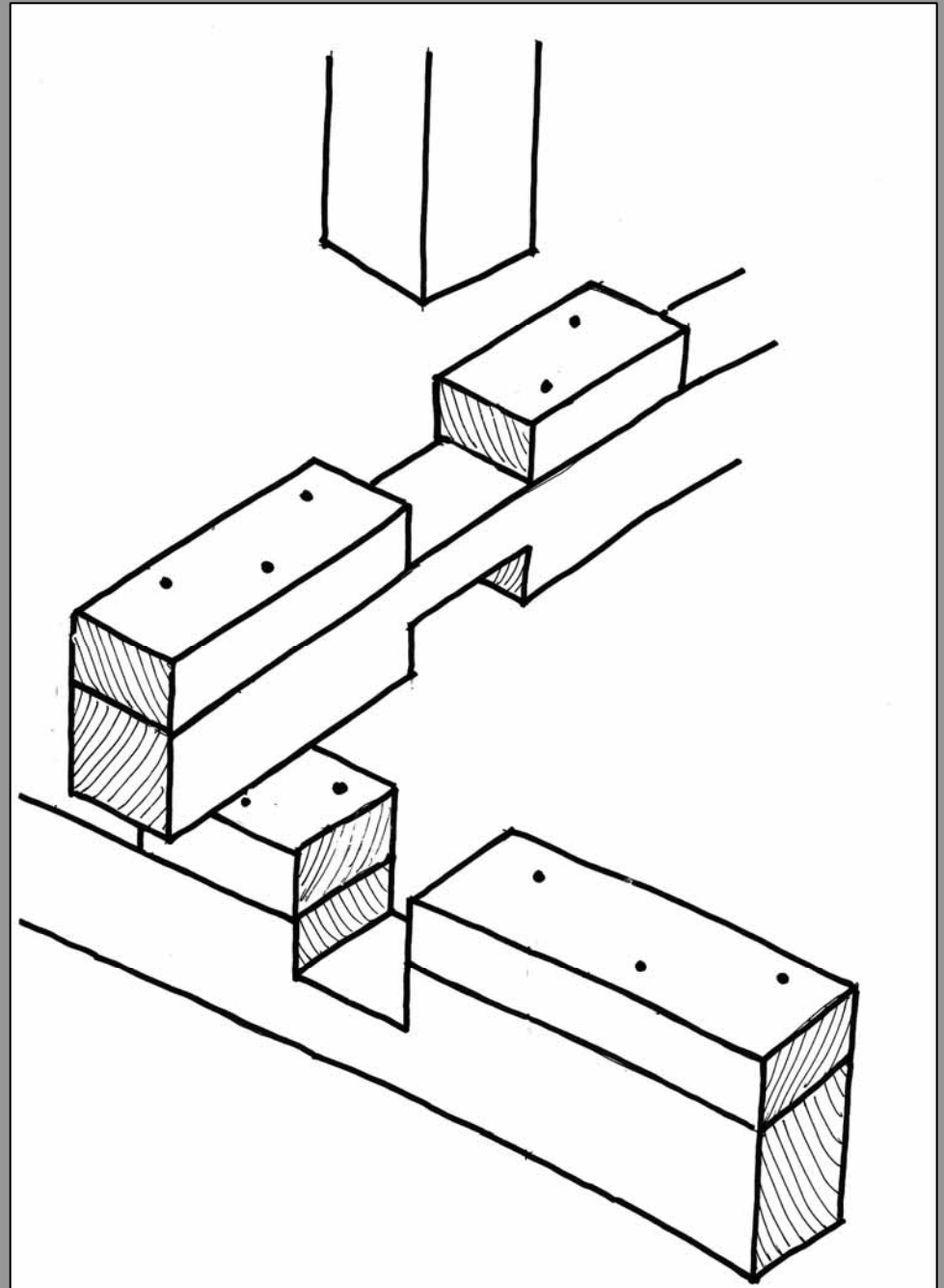

Added blocks:

- Add 2"x4" blocks:
- 12" long on the outside
- 10" long on the inside.
- Nail them with three 4" nails each to the dasa.

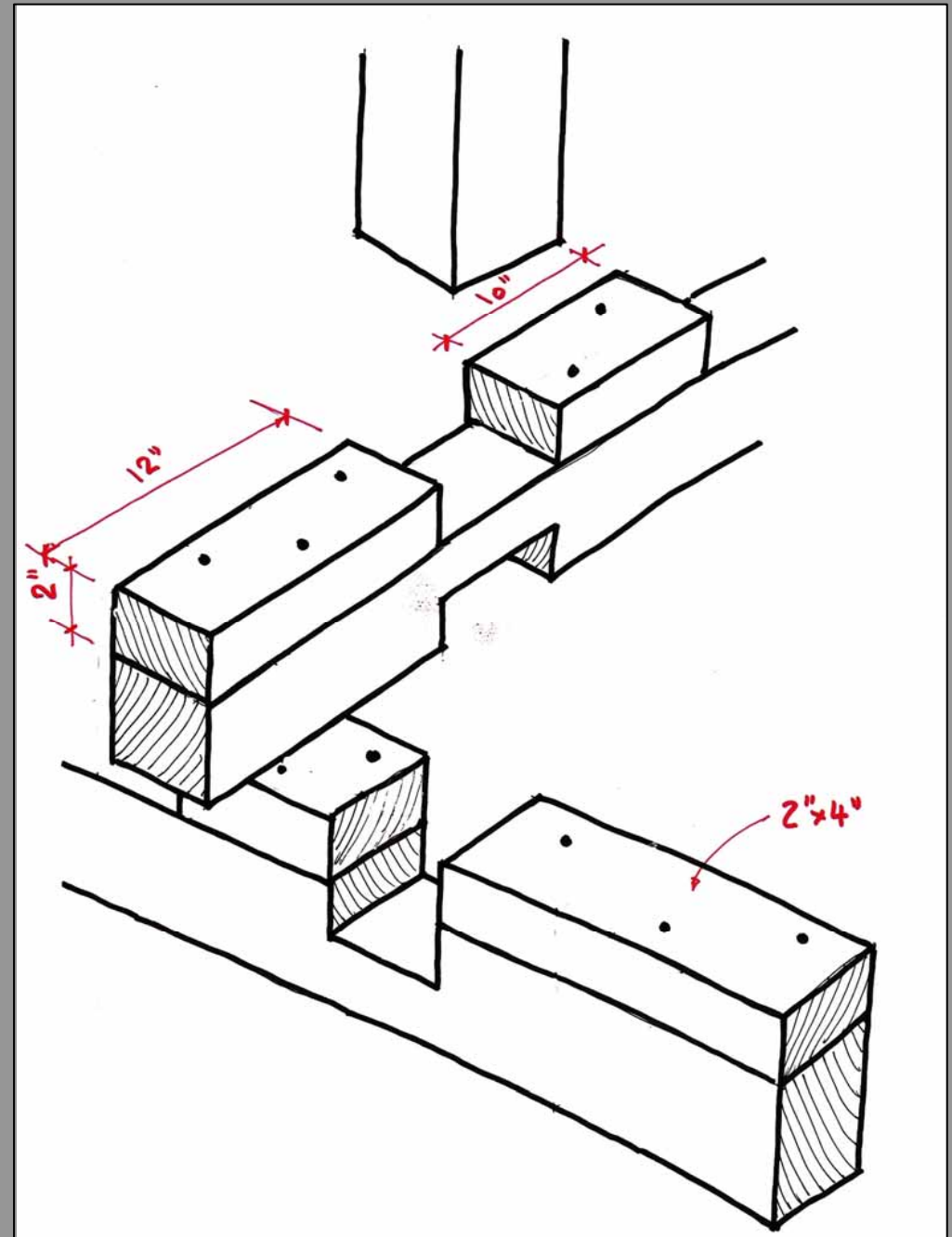

Added blocks:

- Add the corner post

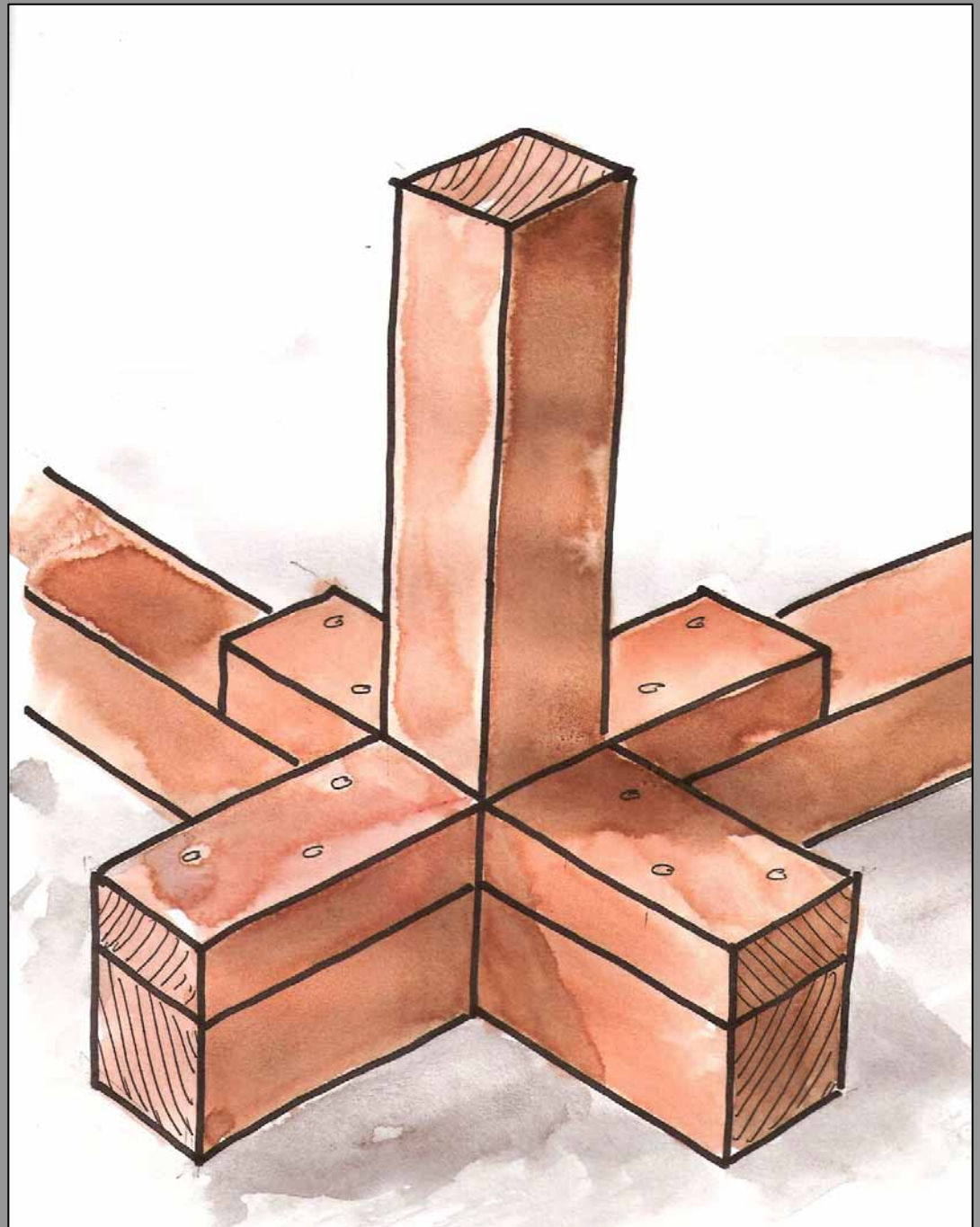

Added blocks:

- Add the corner post
- Fix it with two diagonal boards nailed as shown.

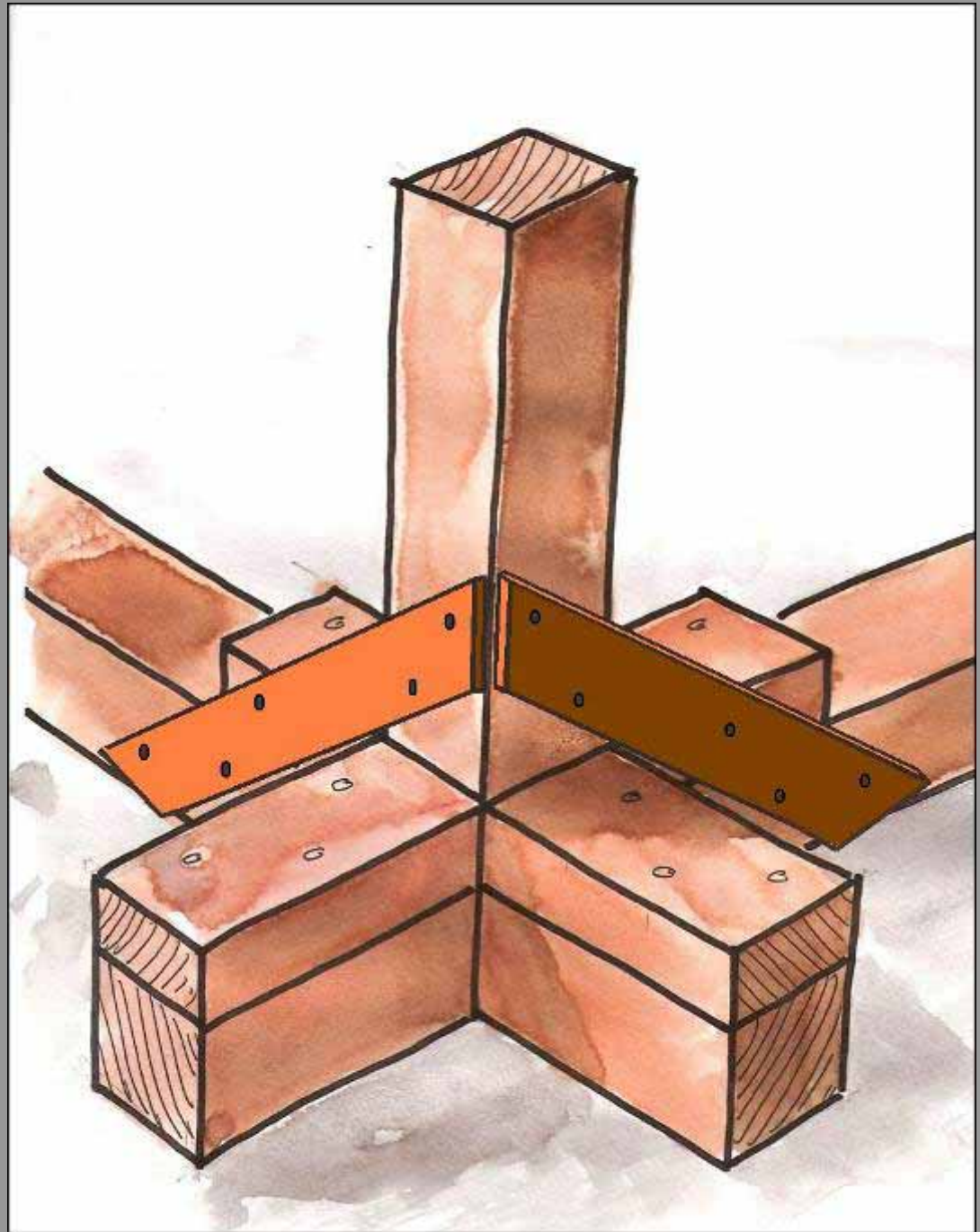

- The connection and the strap shown in the picture is insufficient!
- Why?

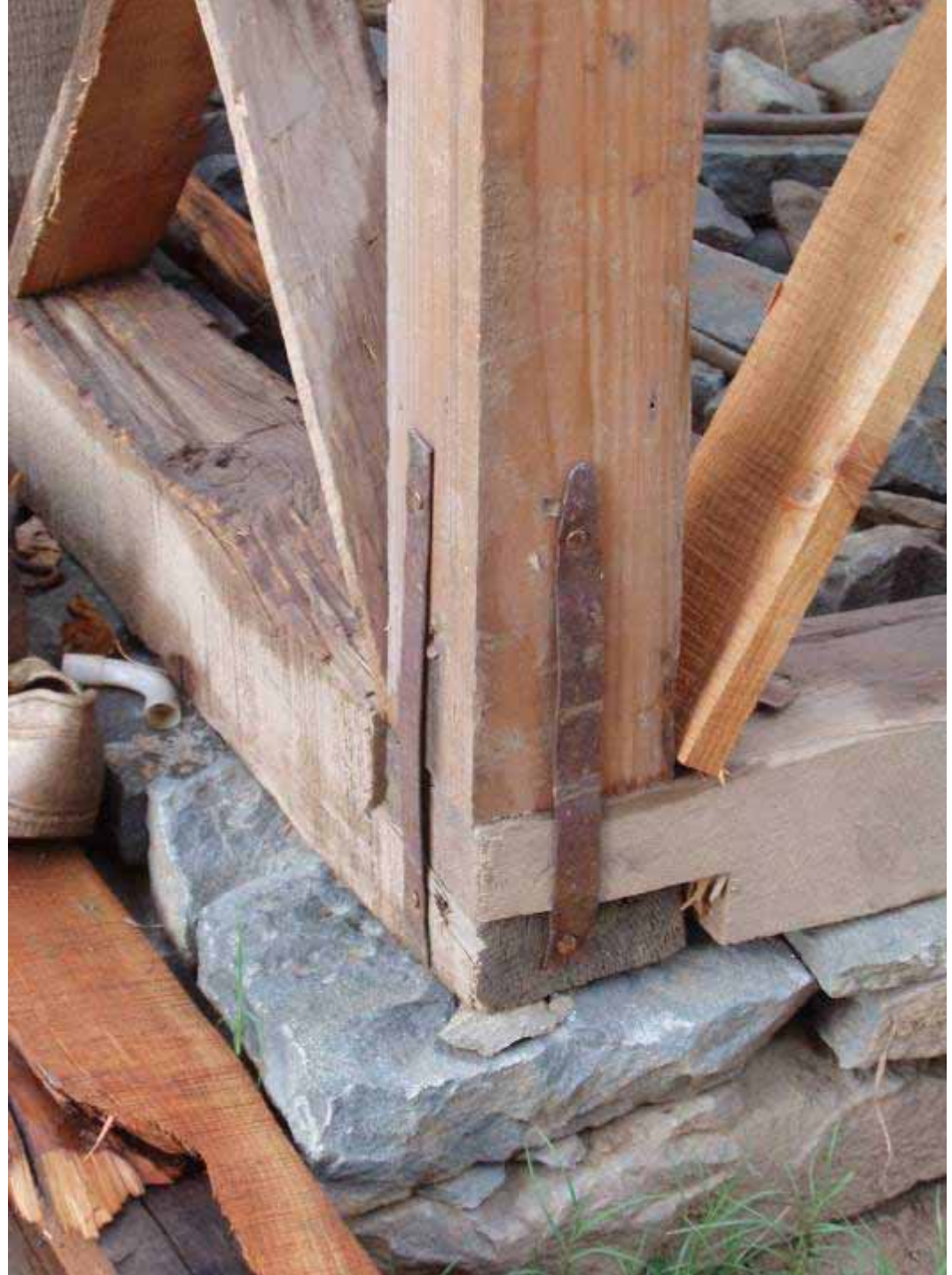

- This connection and strap are even worse.
- Why?



- What is wrong with these connections?



- Straps alone are insufficient to connect the timber pieces.
- They block movements only in one direction.

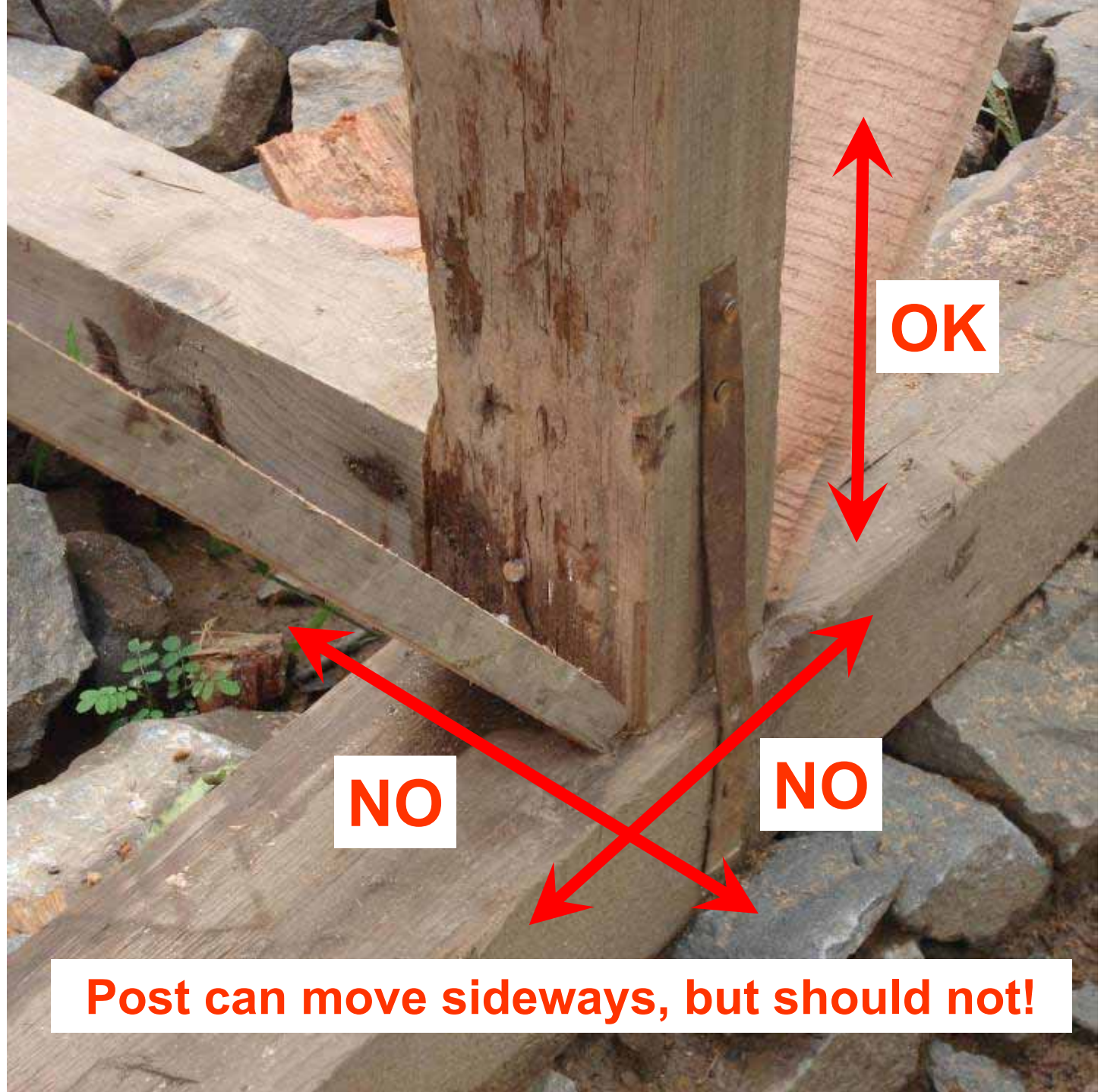

- This strap is connecting pieces which are too far away from each other.
- It's of no use, as the pieces will move.





6. Roof trusses

- Three types of trusses
- Where to place the trusses
- Cross-bracing of the trusses

The elements of a roof truss

- A roof truss has at least:

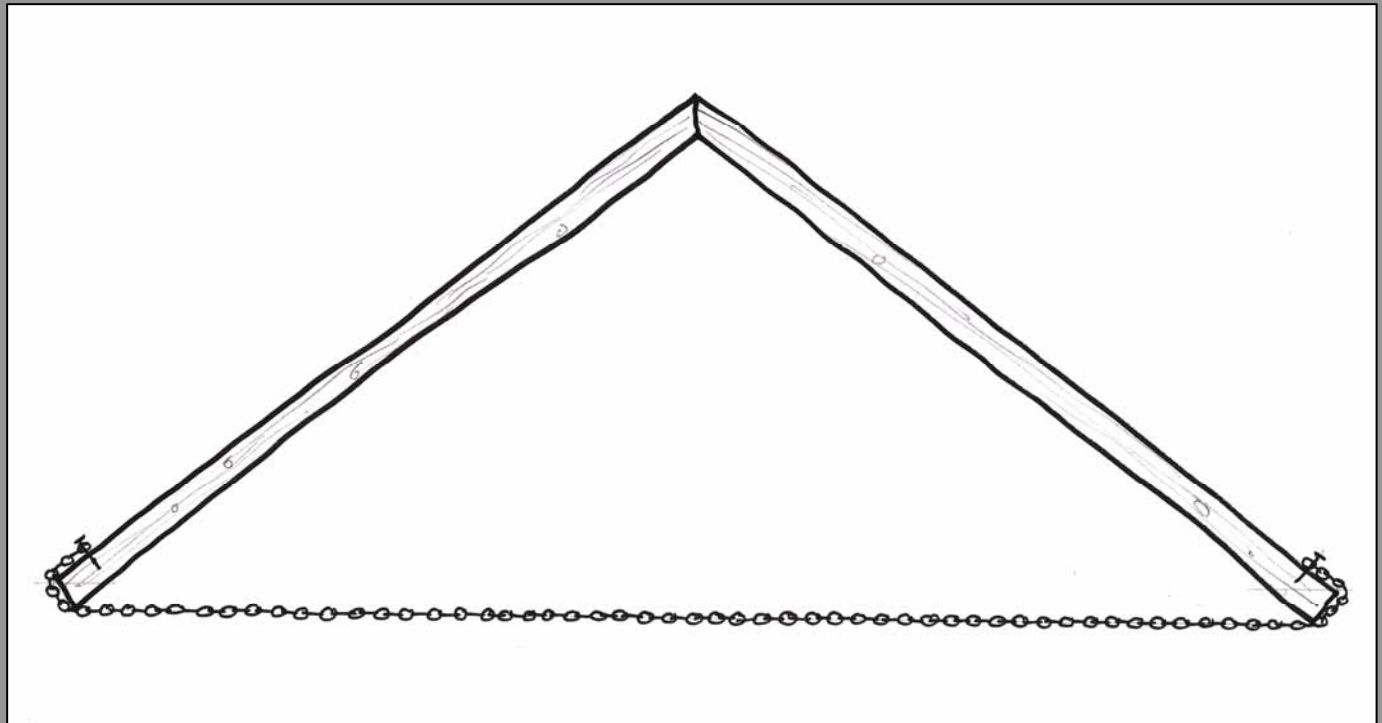

The elements of a roof truss

- A roof truss has at least:
- Two rafters

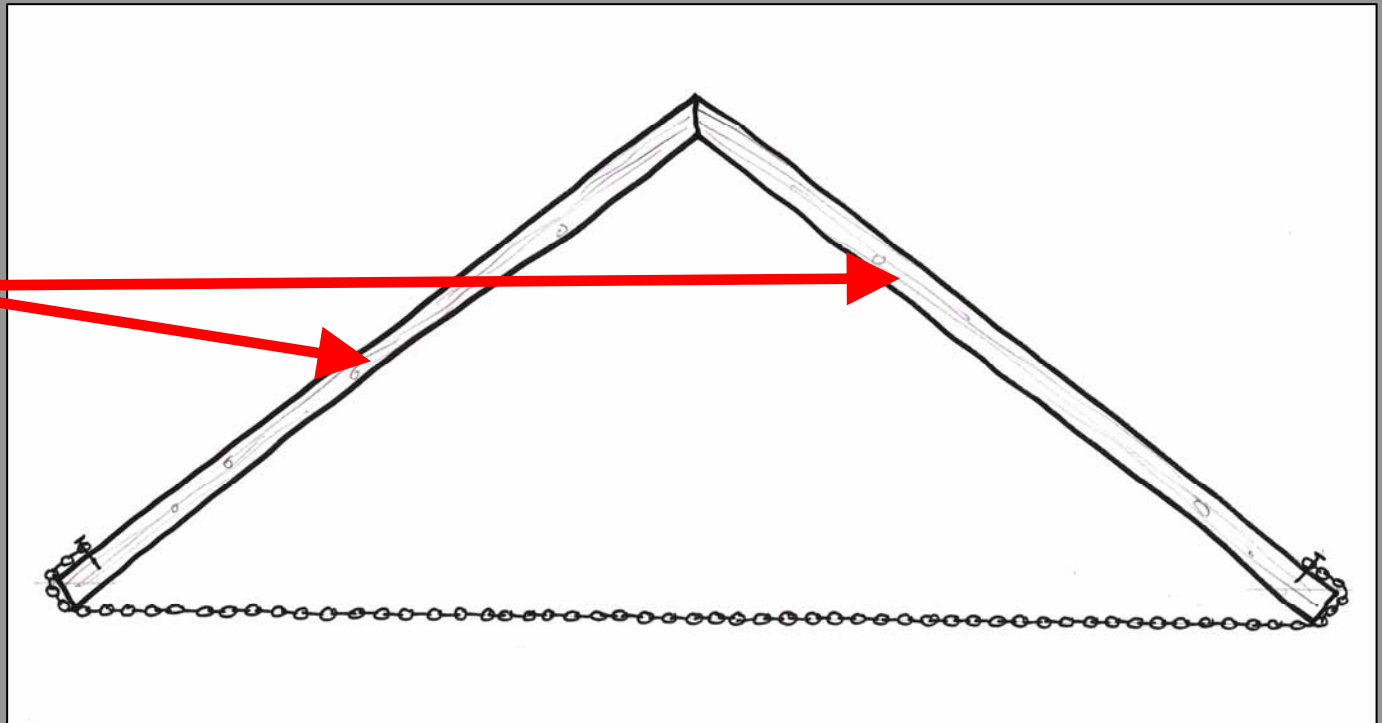

The elements of a roof truss

- A roof truss has at least:
- Two rafters
- One tie

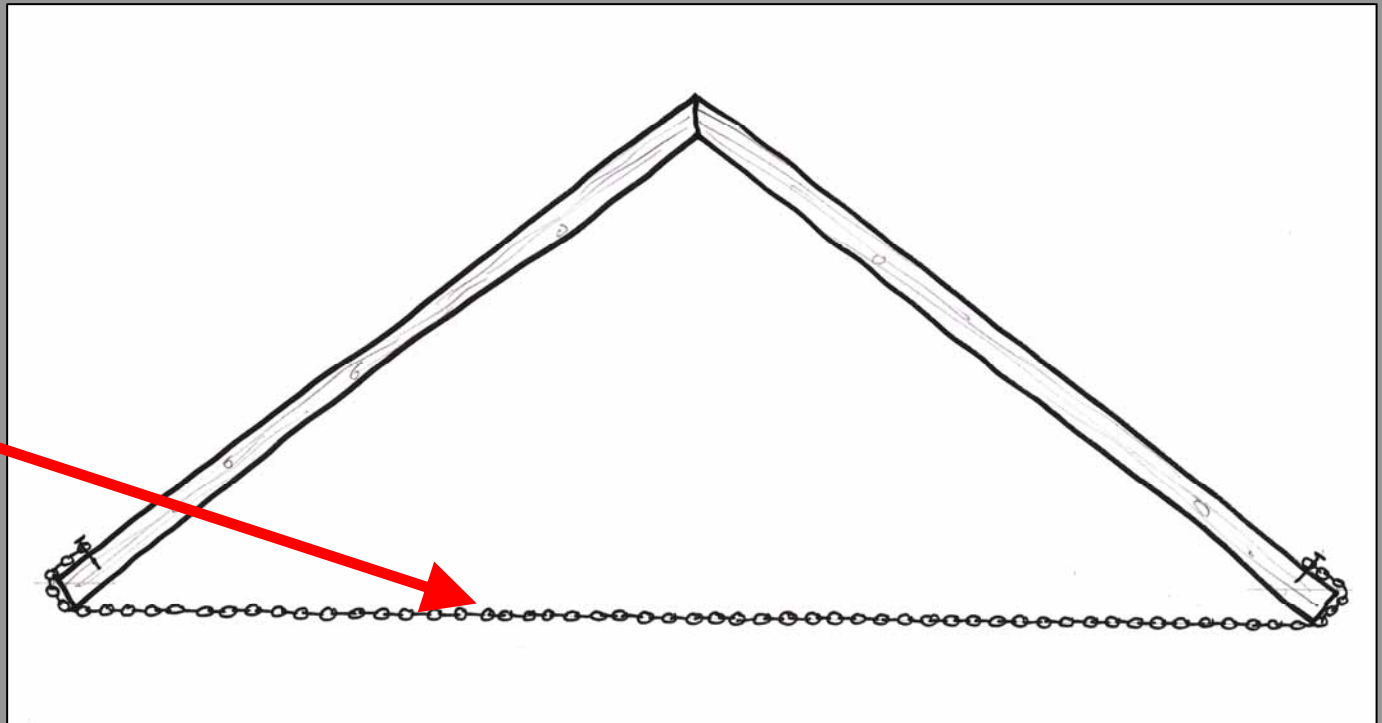

What is a Tie-Beam?

- A tie-beam holds (ties) together the two rafters like chain.
- How would the rafters move without the tie?

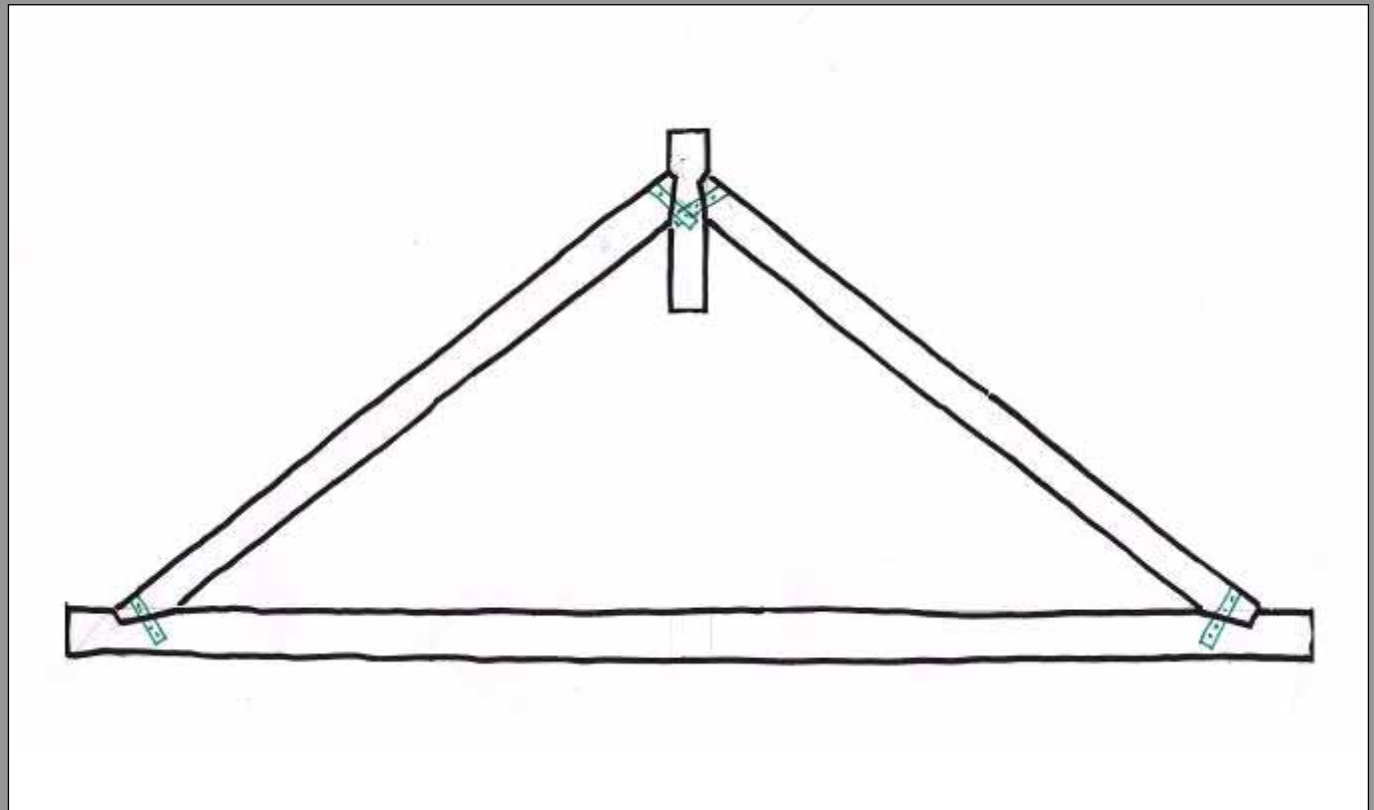

The 3 types of trusses

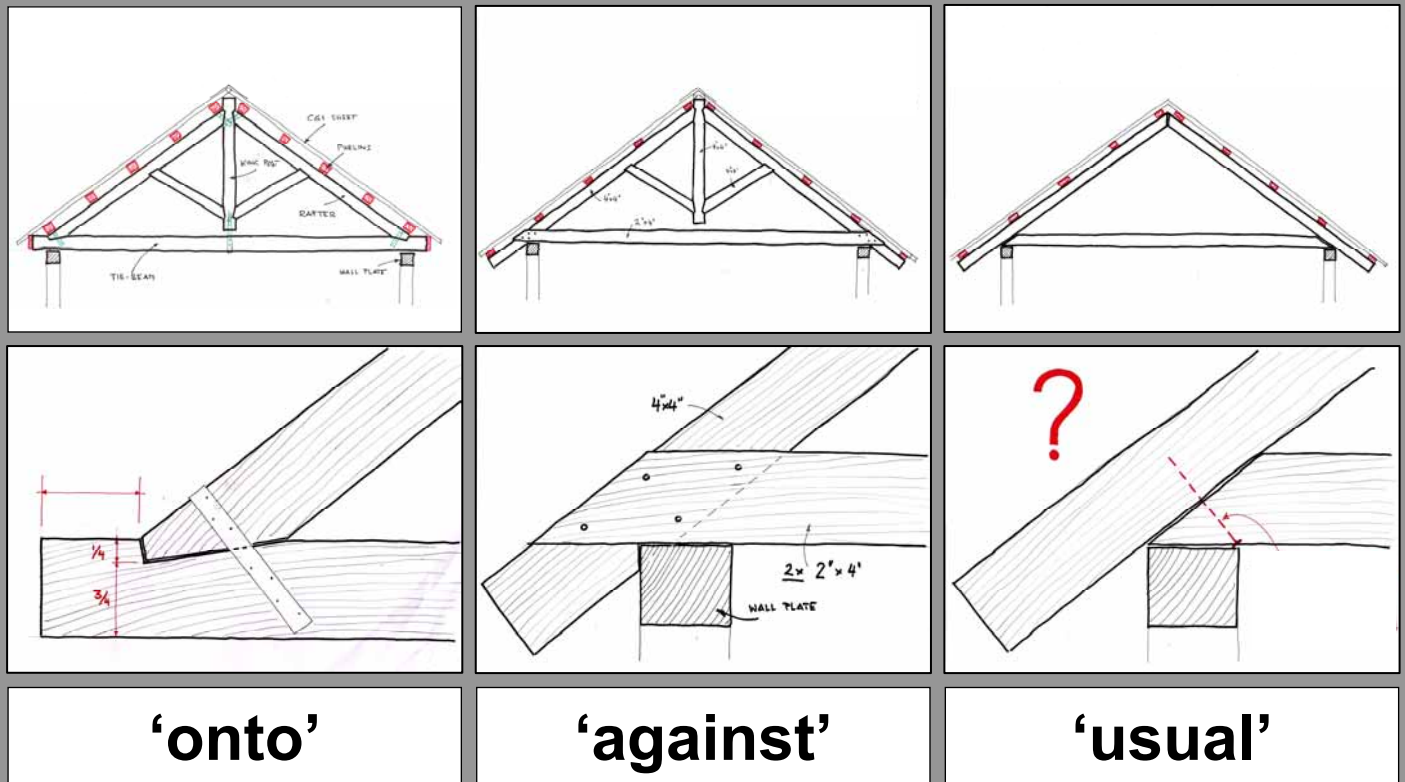

Truss with rafters placed ONTO the tie-beam

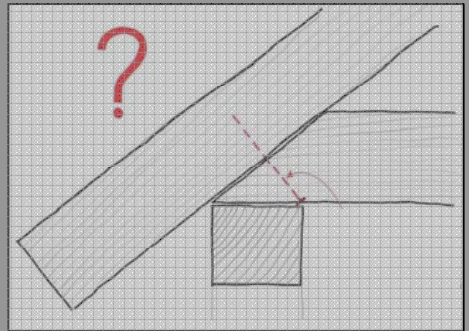
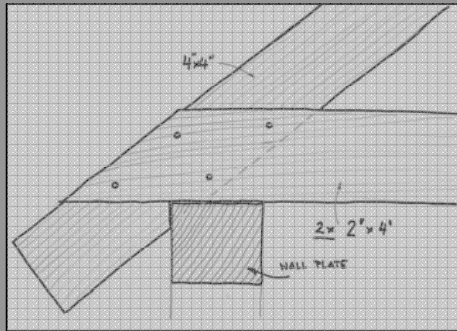
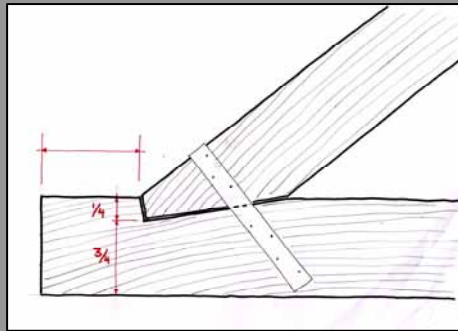
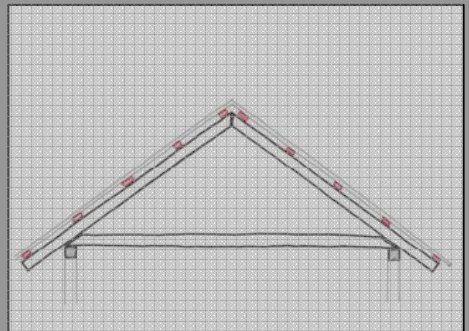
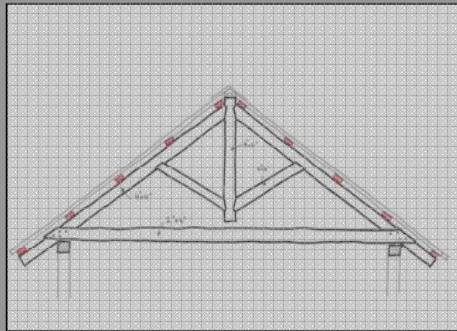
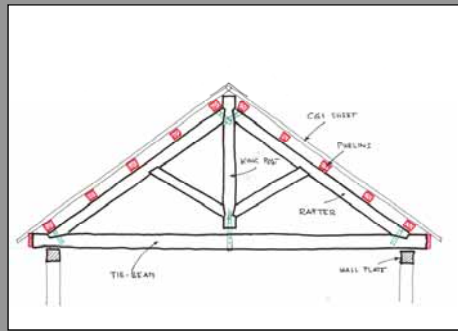

'onto'

'against'

'usual'

Truss with rafters placed ONTO the tie-beam

- The rafters are 'stuck' onto the tie beam.
- This way, the tie-beam can work at its full capacity.

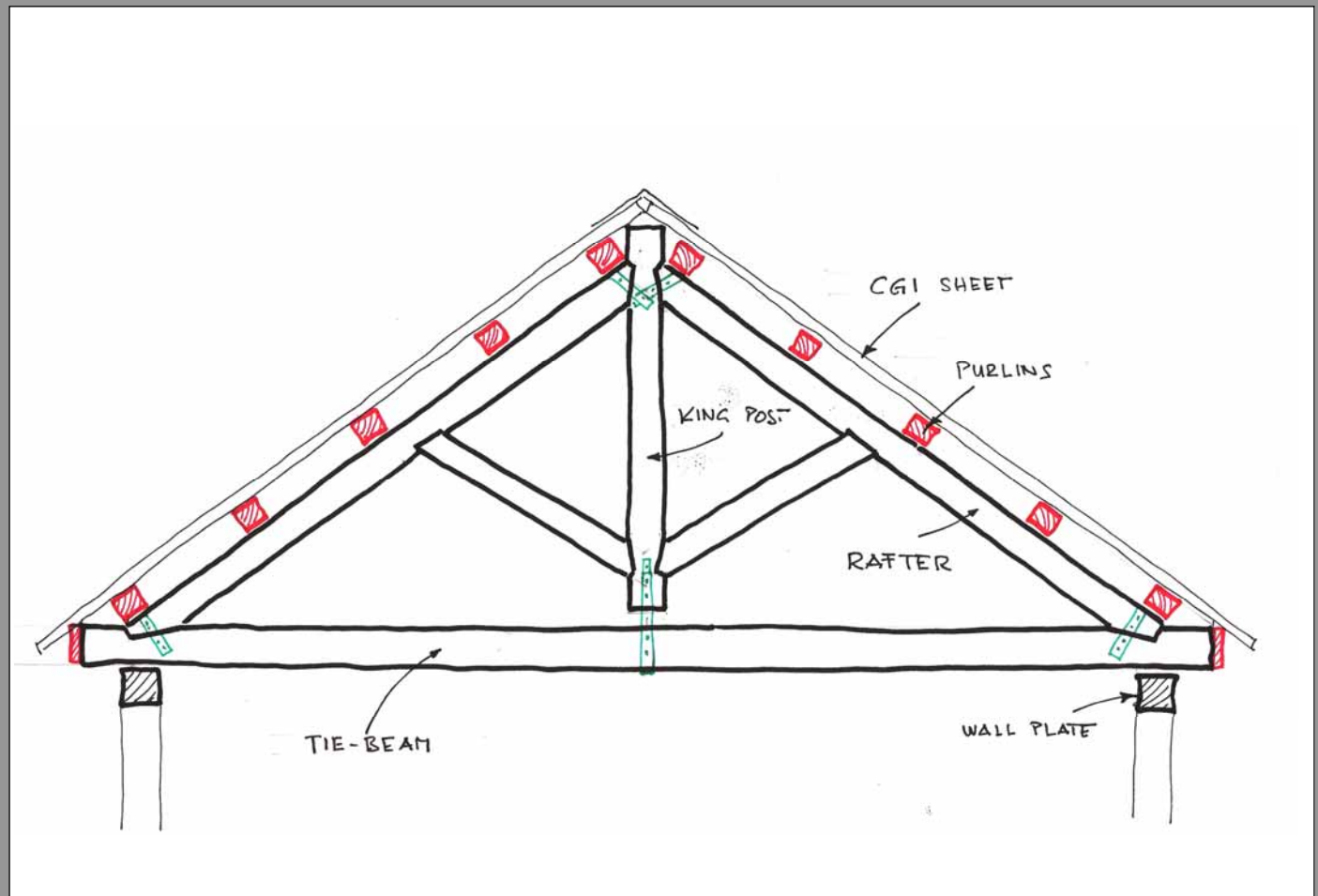

Truss with rafters placed ONTO the tie-beam

- Leave at least as much wood after the joint as the beam is high.

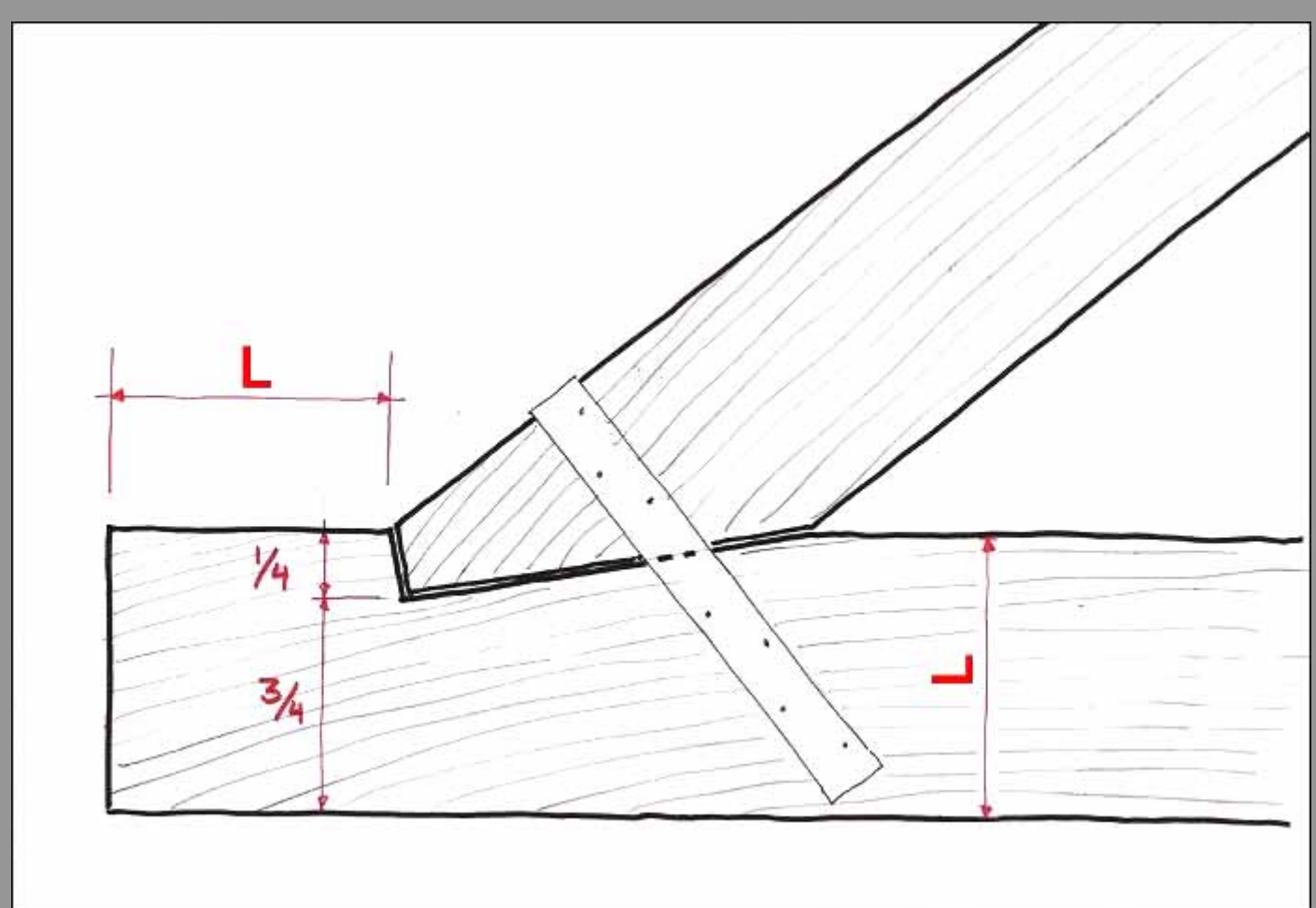

Truss with rafters placed ONTO the tie-beam

- The inclination of the stop-splay should be half the angle between tie beam and rafter.

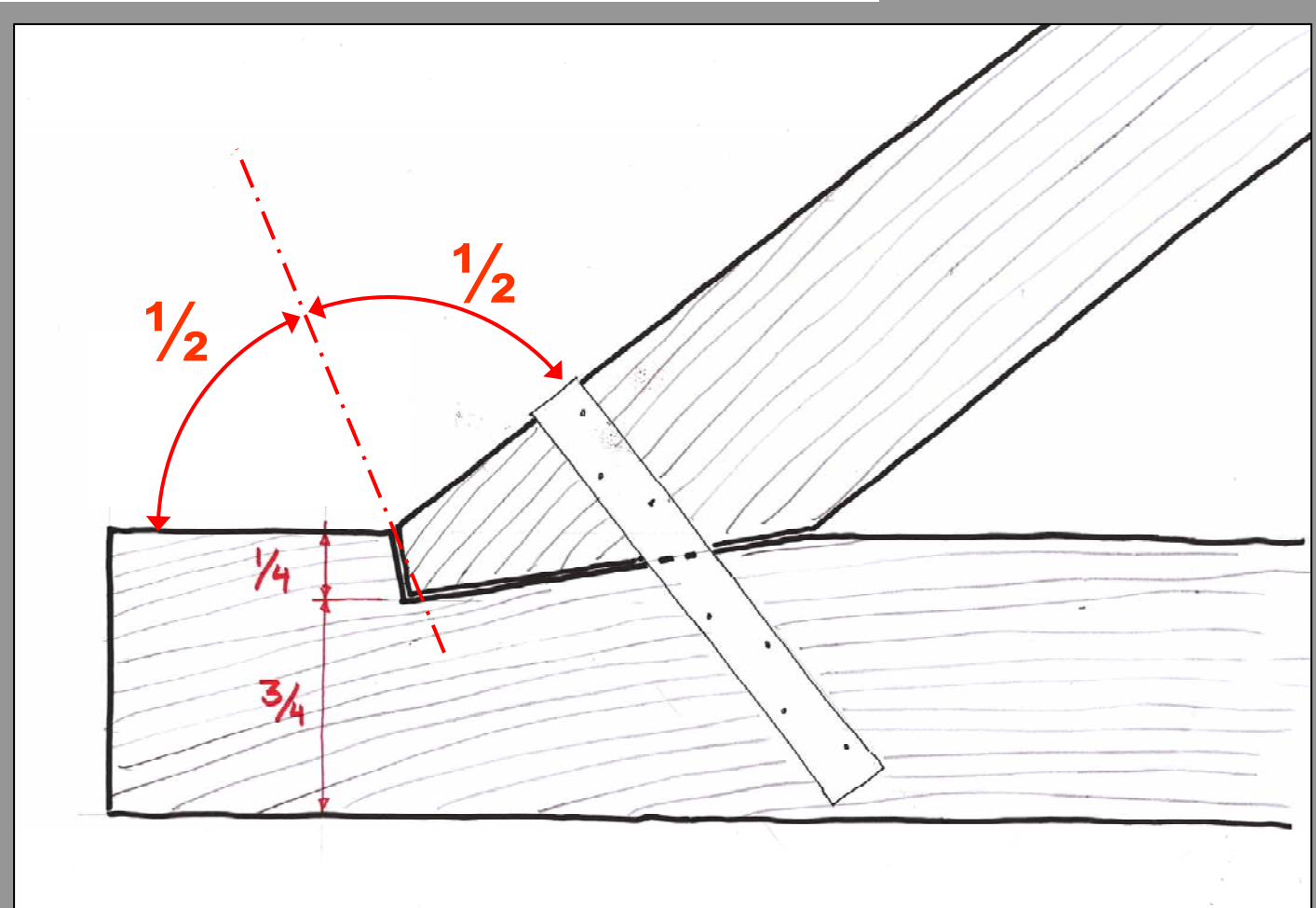

Truss with rafters placed ONTO the tie-beam

- Secure the rafters with straps...

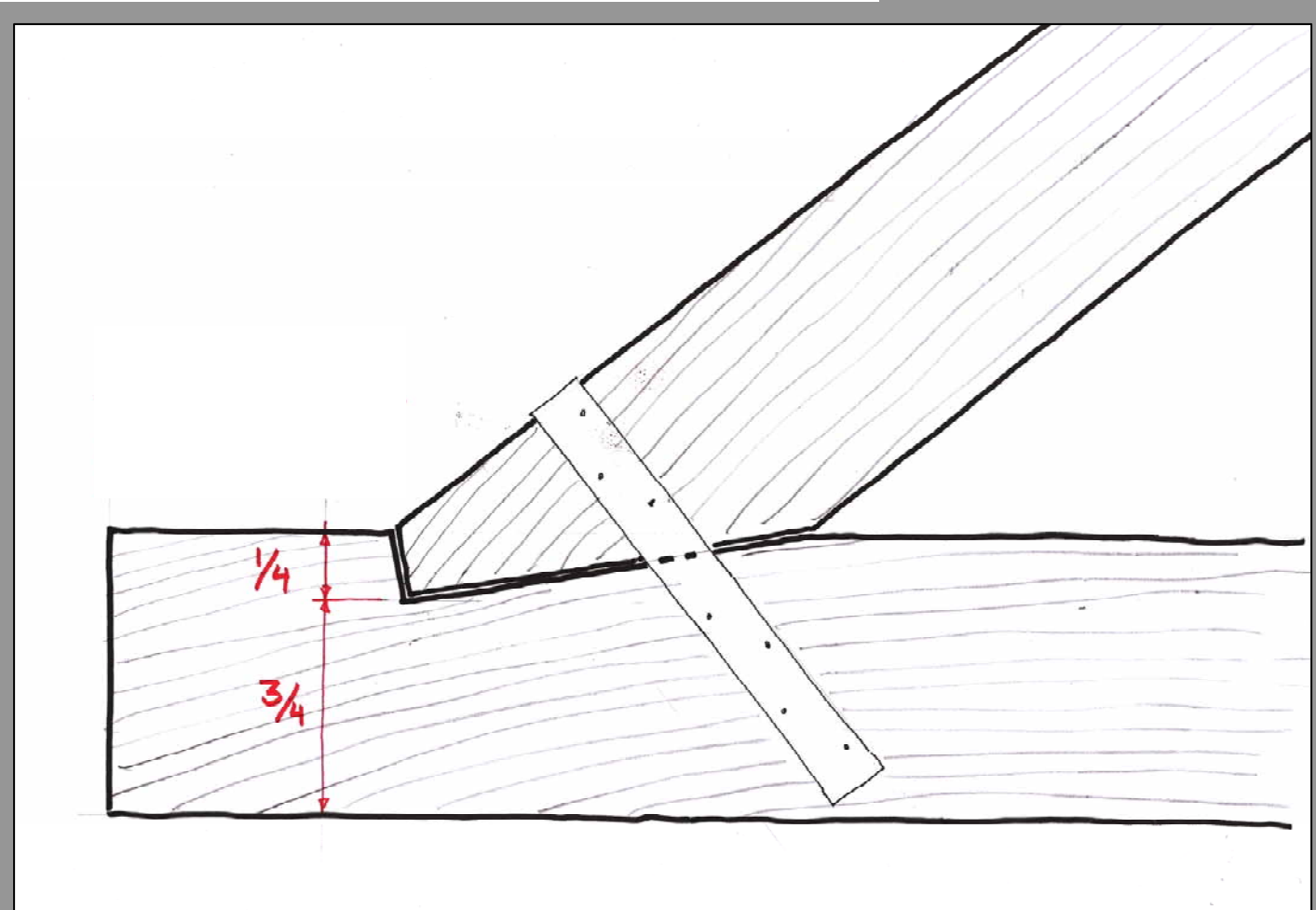

Truss with rafters placed ONTO the tie-beam

- .. or 5" nails put in the same position as the straps.

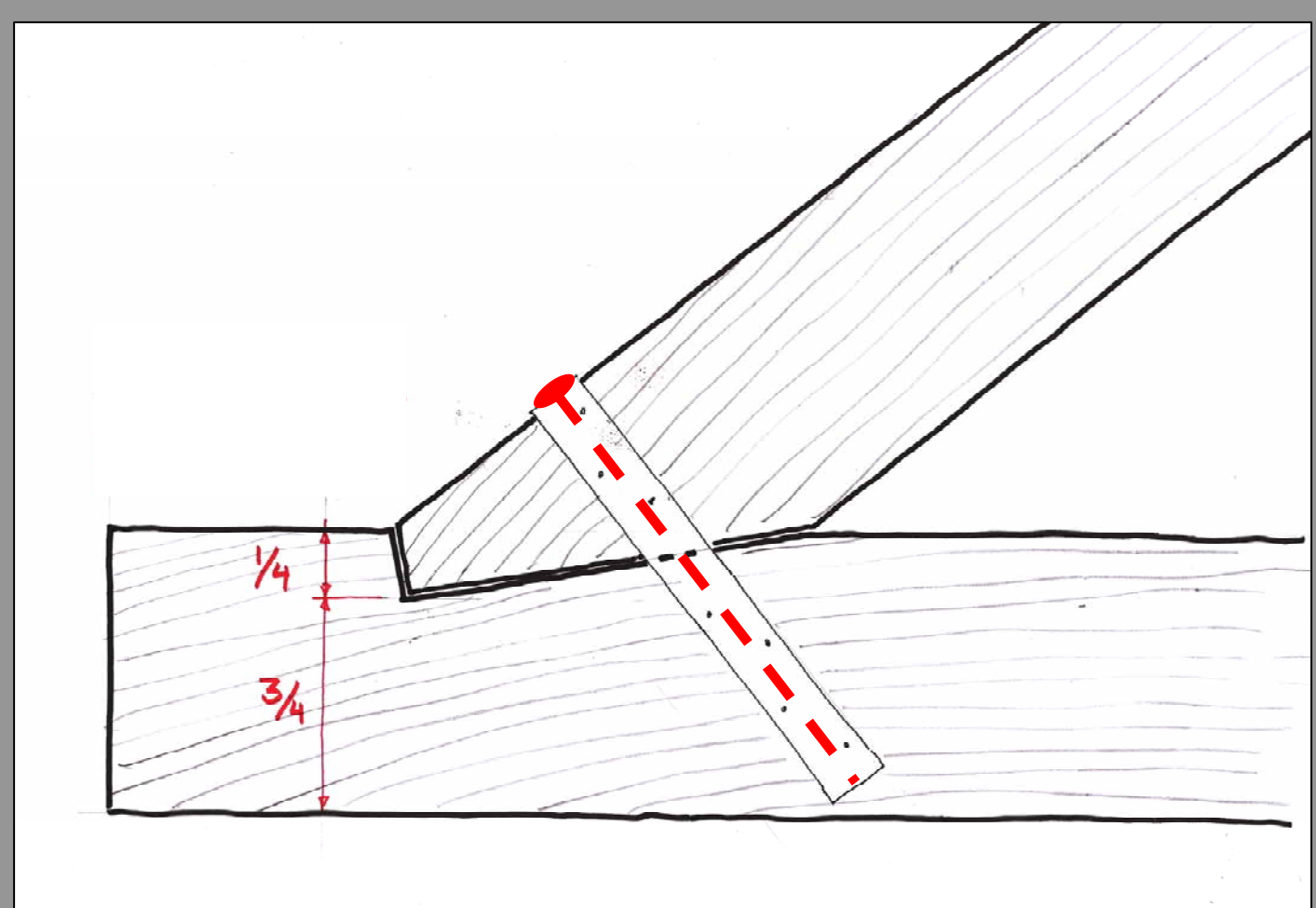

Truss with double tie-beams AGAINST the rafters

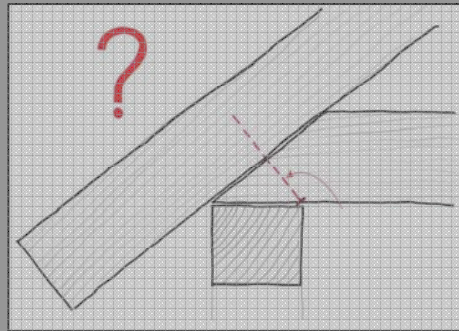
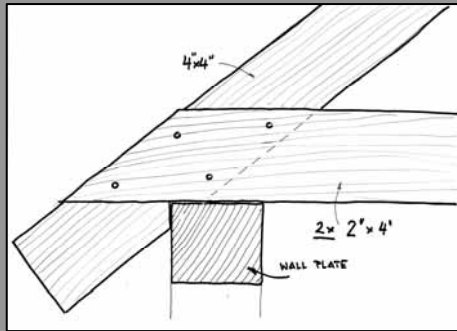
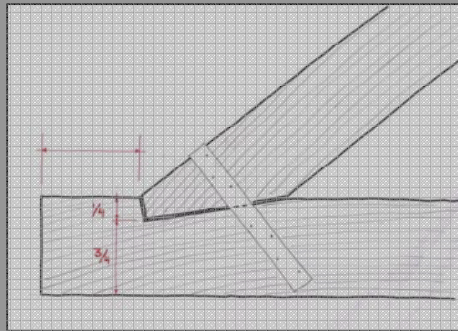
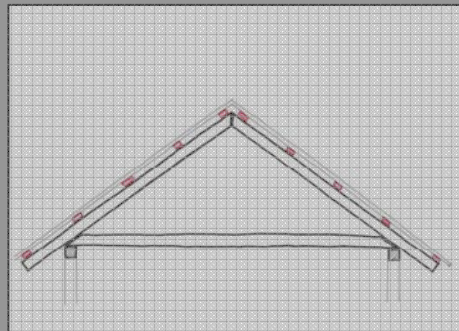
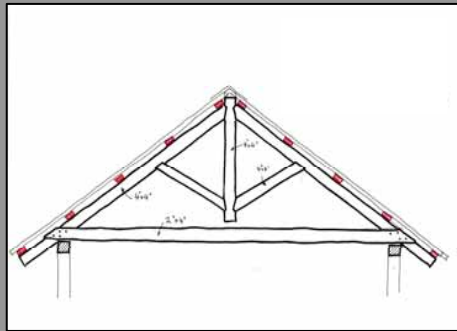
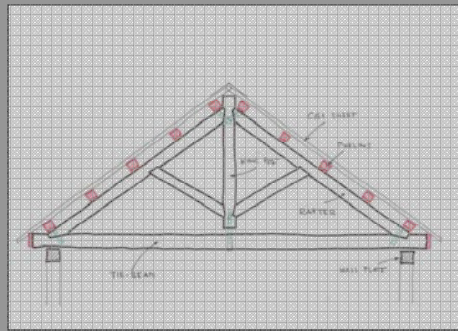

'onto'

'against'

'usual'

Truss with double tie-beams AGAINST the rafters

- Here the tie-beam is cut in two halves of 2"x4" each.
- They hold the rafters from the side.

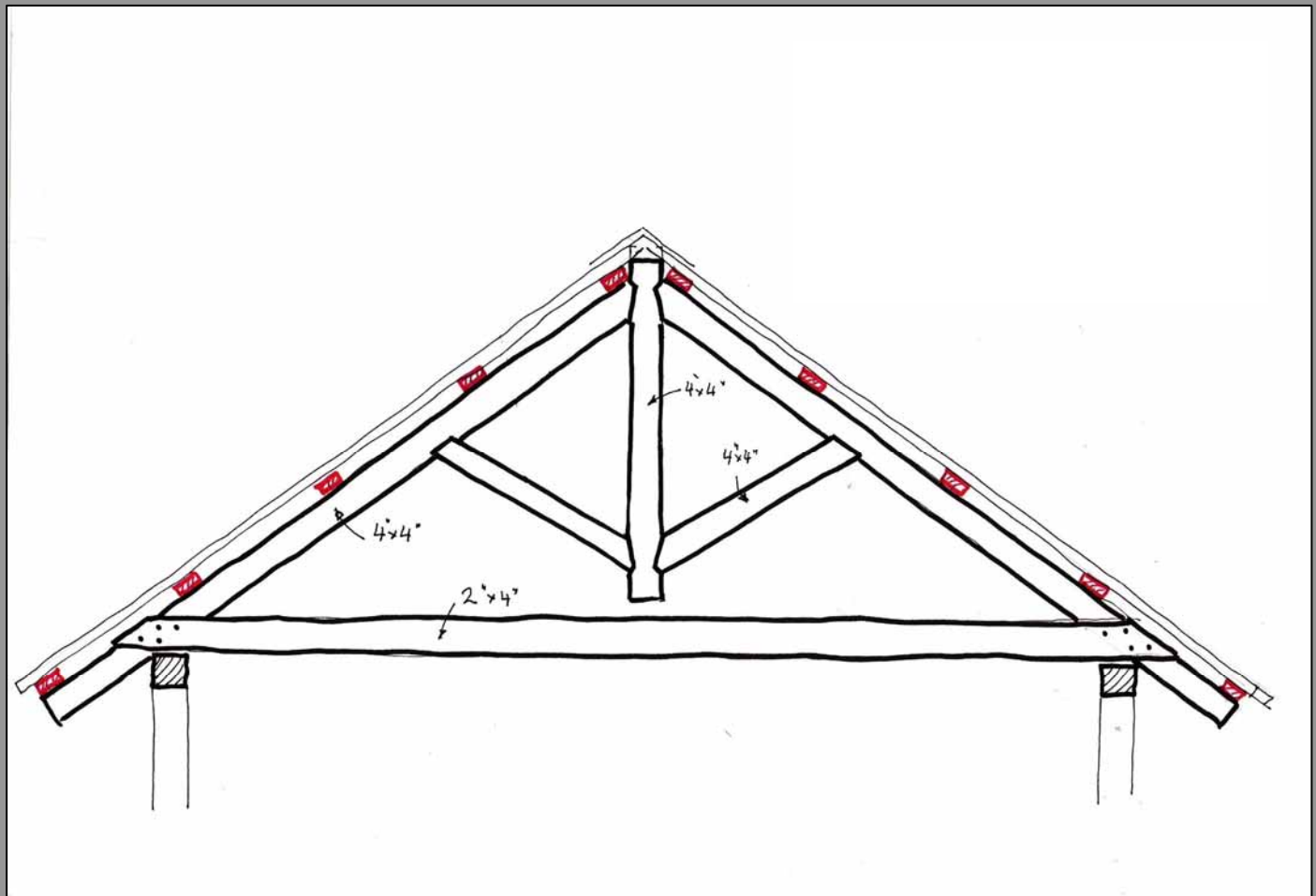

Truss with double tie-beams AGAINST the rafters

- The 2"x4" tie-beams are nailed against the rafter from both sides.
- Use four 4" nails on each side.

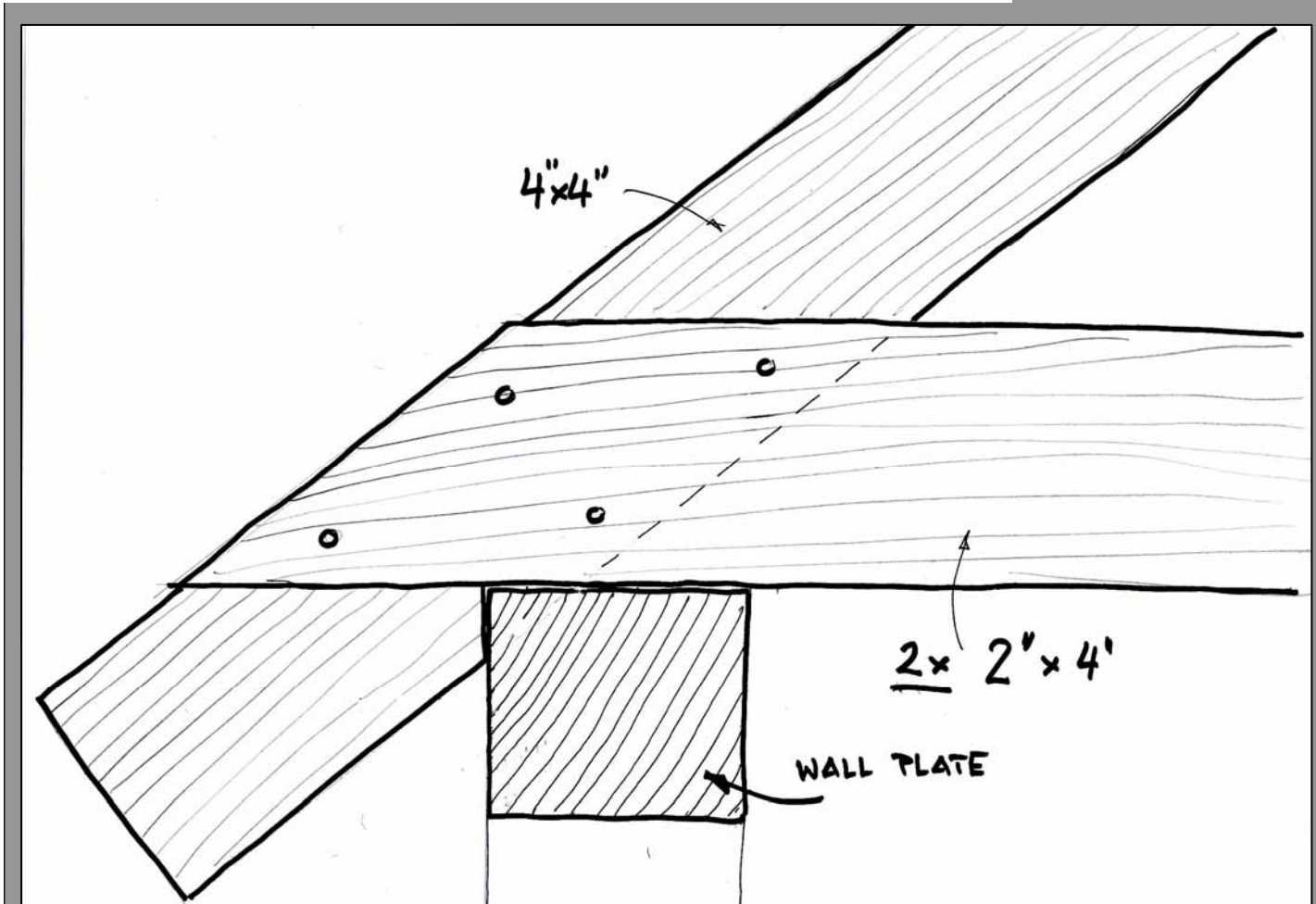



Truss with double tie-beams **AGAINST** the rafters

- To make good roof trusses, connect the rafters with lateral tie beams.



Two tie beams nailed against rafter

'Usual truss' with a NON-FUNCTIONAL tie-beam

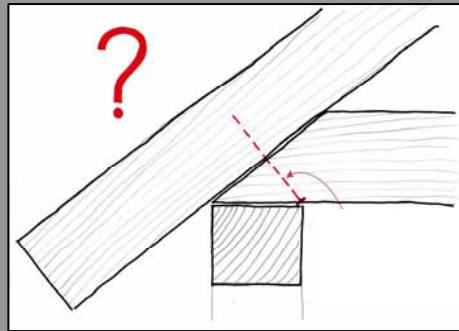
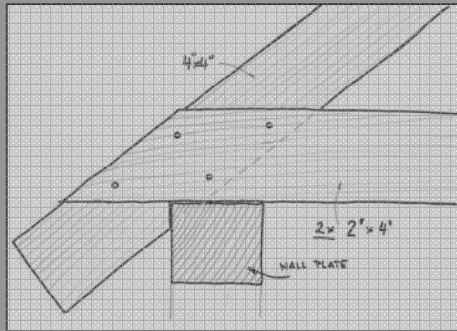
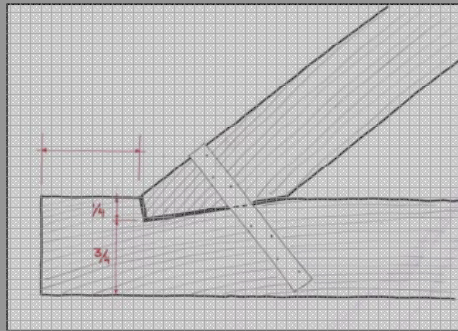
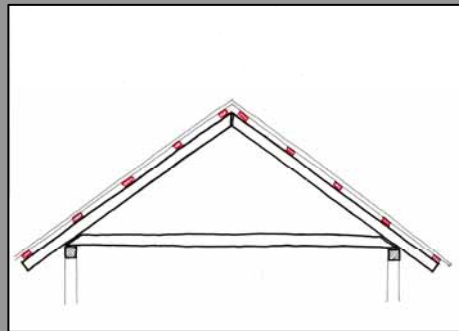
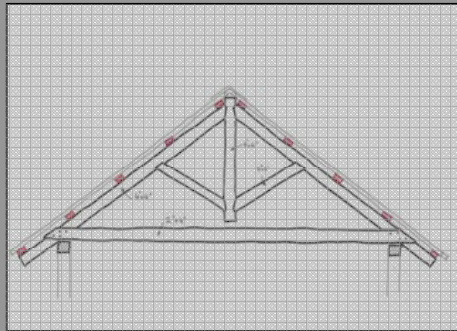
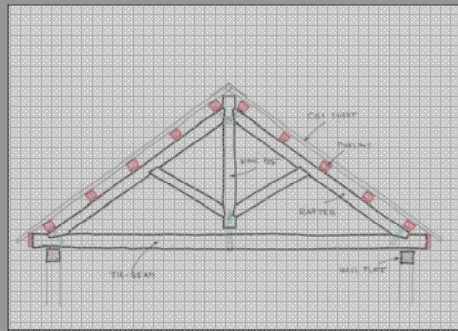

'onto'

'against'

'usual'

'Usual truss' with a NON-FUNCTIONAL tie-beam

- This is not a good truss.
- The tie-beam cannot do its job.
- Why?

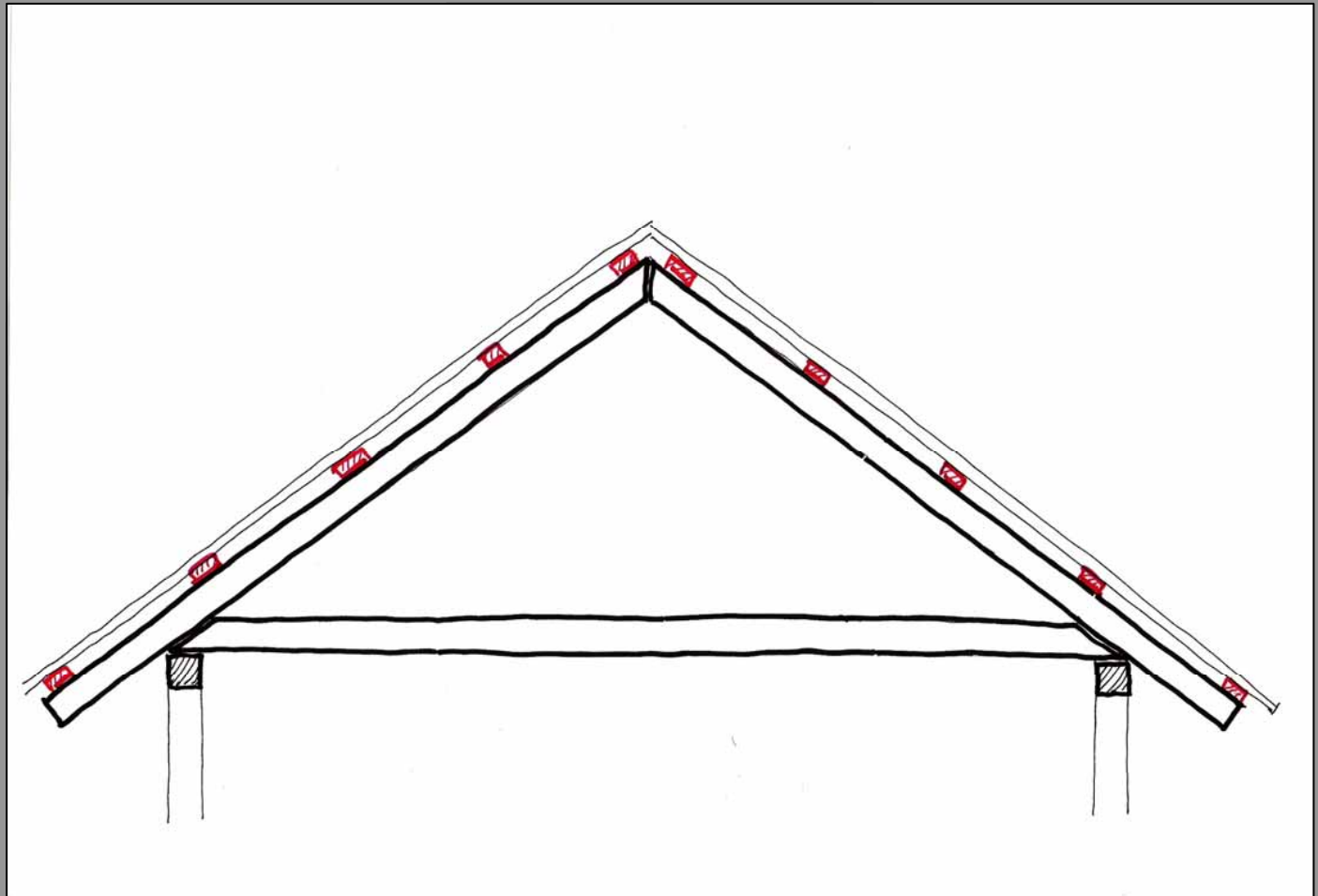

'Usual truss' with a NON-FUNCTIONAL tie-beam

- The whole strength of the truss depends only on these nails.
- They can be pulled out easily.

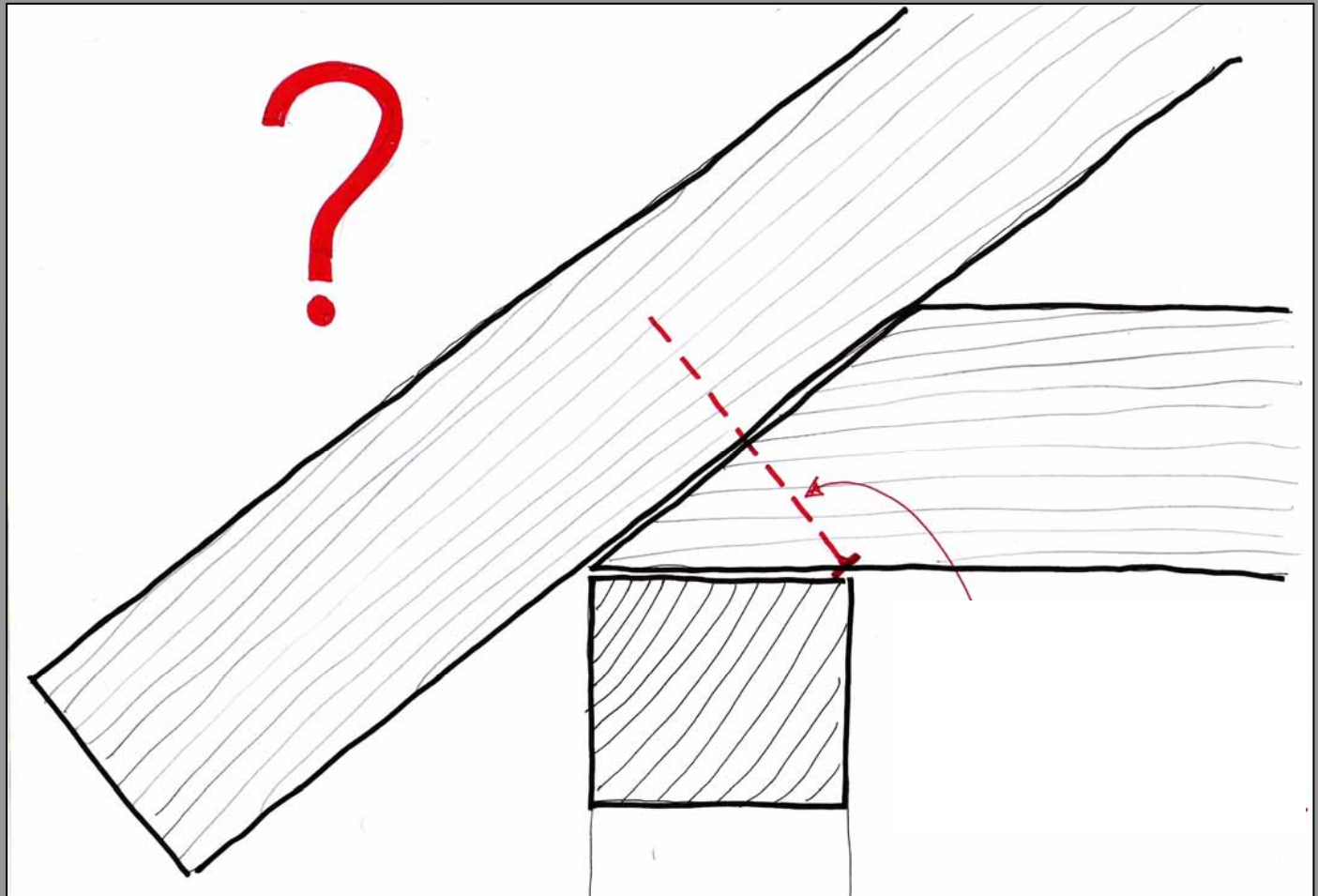



'Usual truss' with a **NON-FUNCTIONAL** tie-beam

- These straps are not able to secure this joint.



‘Usual truss’ with a correct tie-beam joint

- For this truss to work, difficult carpentry work is needed.
- Tenon and mortise joint **plus a**
- Heavy duty strap.

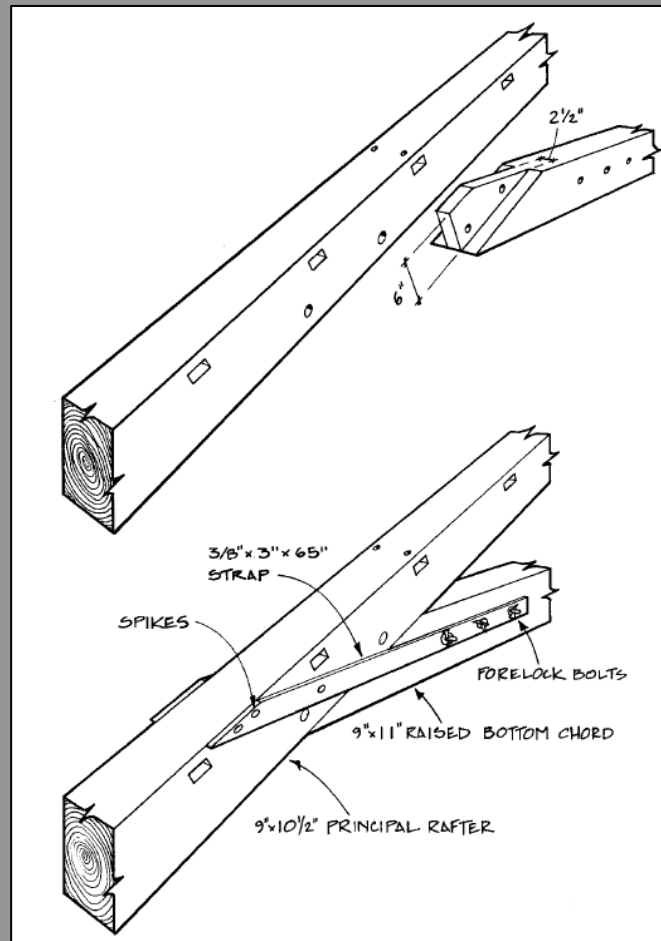

Therefore: only two types of trusses should be used

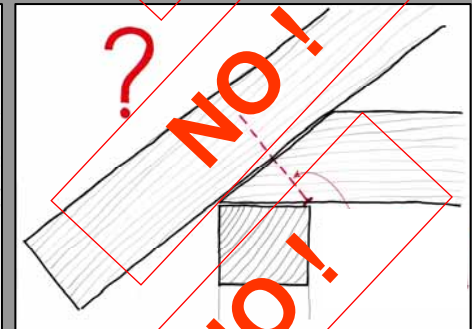
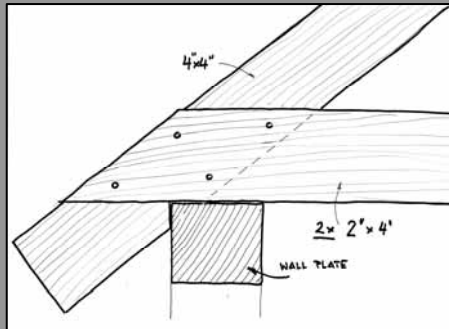
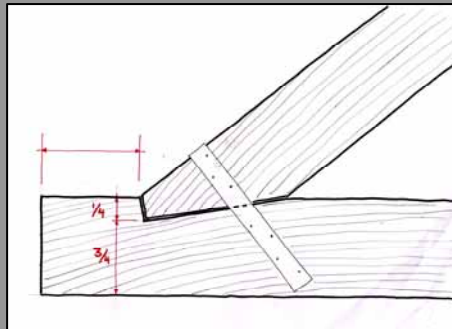
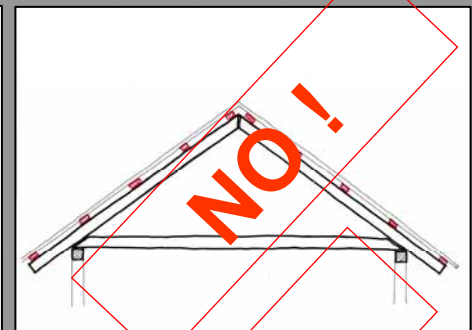
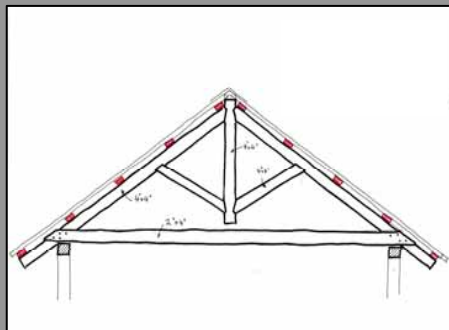
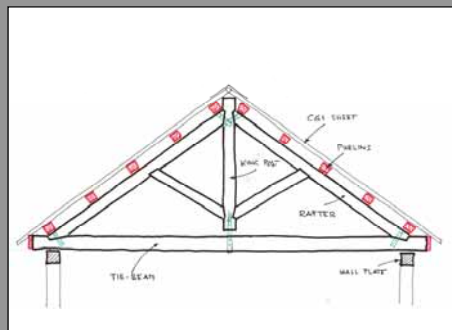

'onto'

'against'

'usual'

Additional truss details

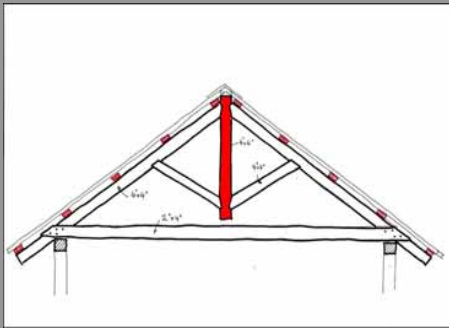

King-post

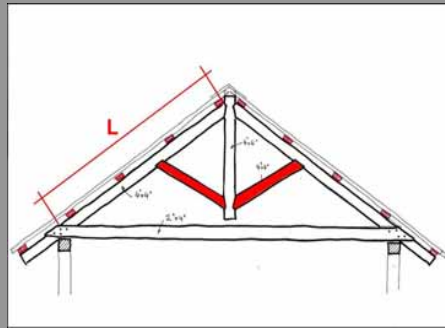

Braces

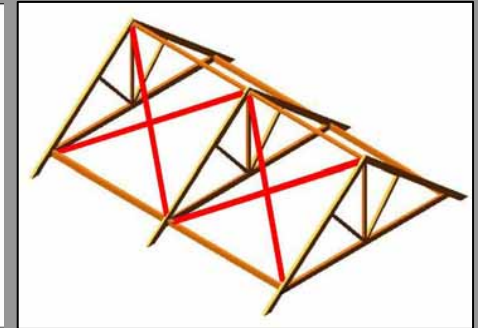

Cross braces

Additional truss details

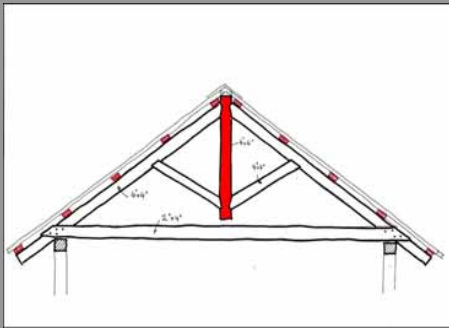

King-post

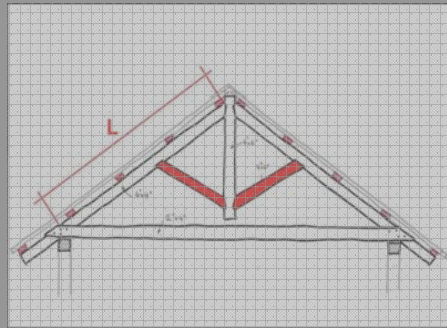

Braces

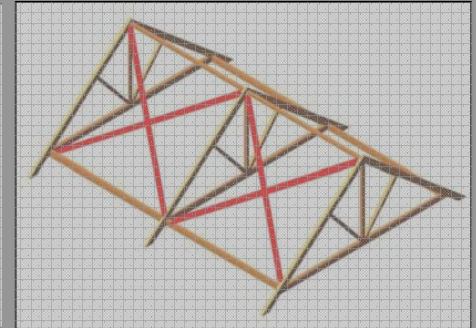

Cross braces

King-post: why do we need it?

- In a truss, rafters move slightly.
- When they move, their ends can break.
- A loose connection is weak.

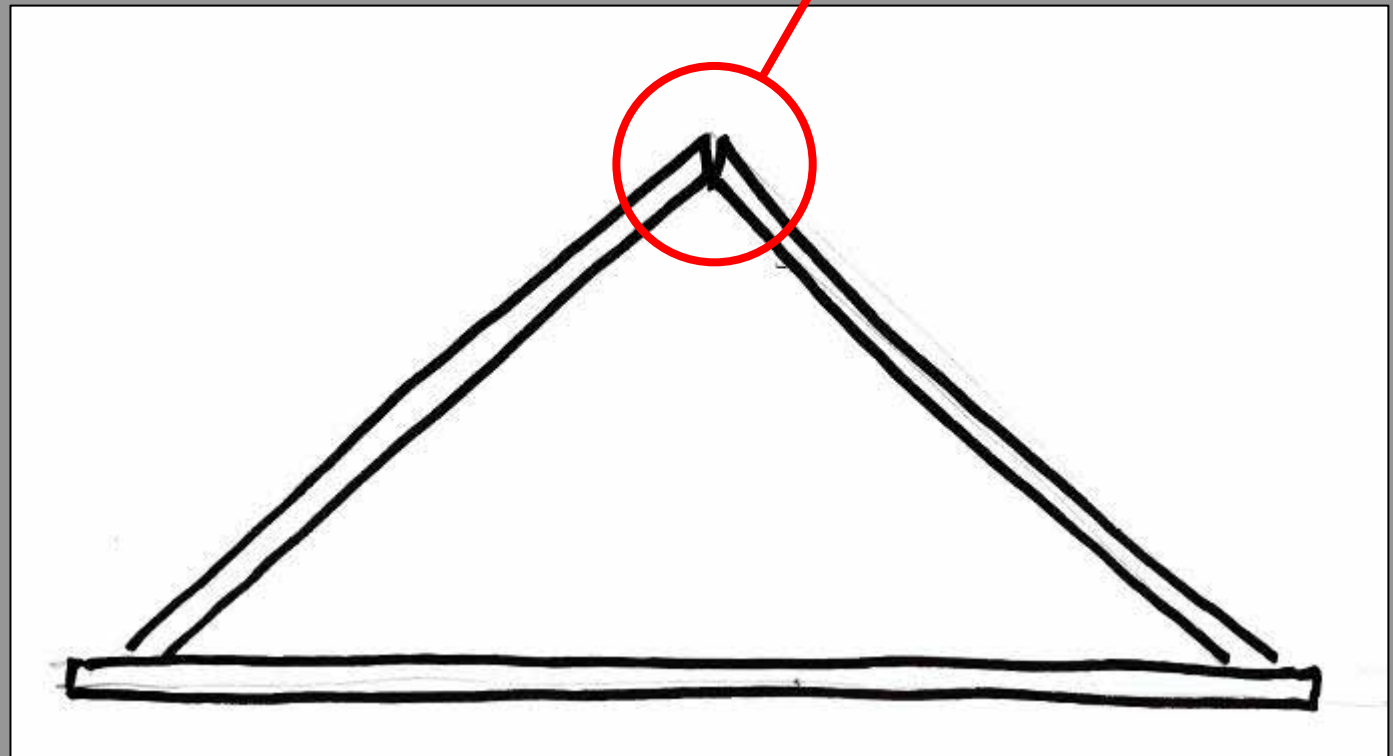
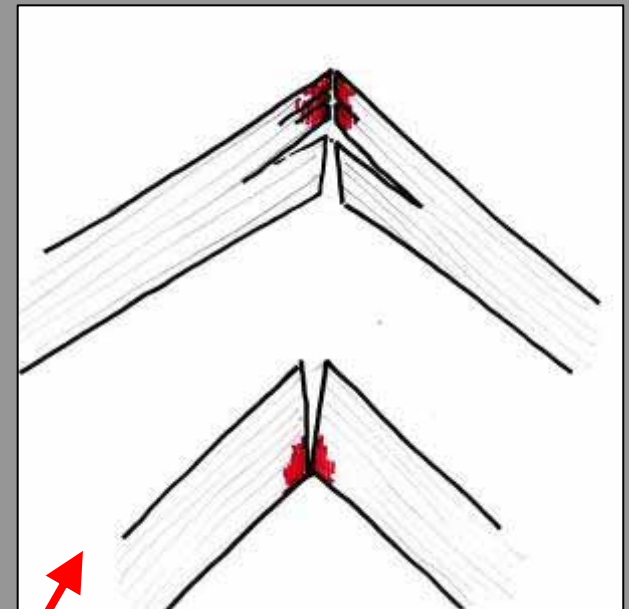

King-post

- Leave as much wood after joint as post is large.
- Secure joint with straps or 5" nails.

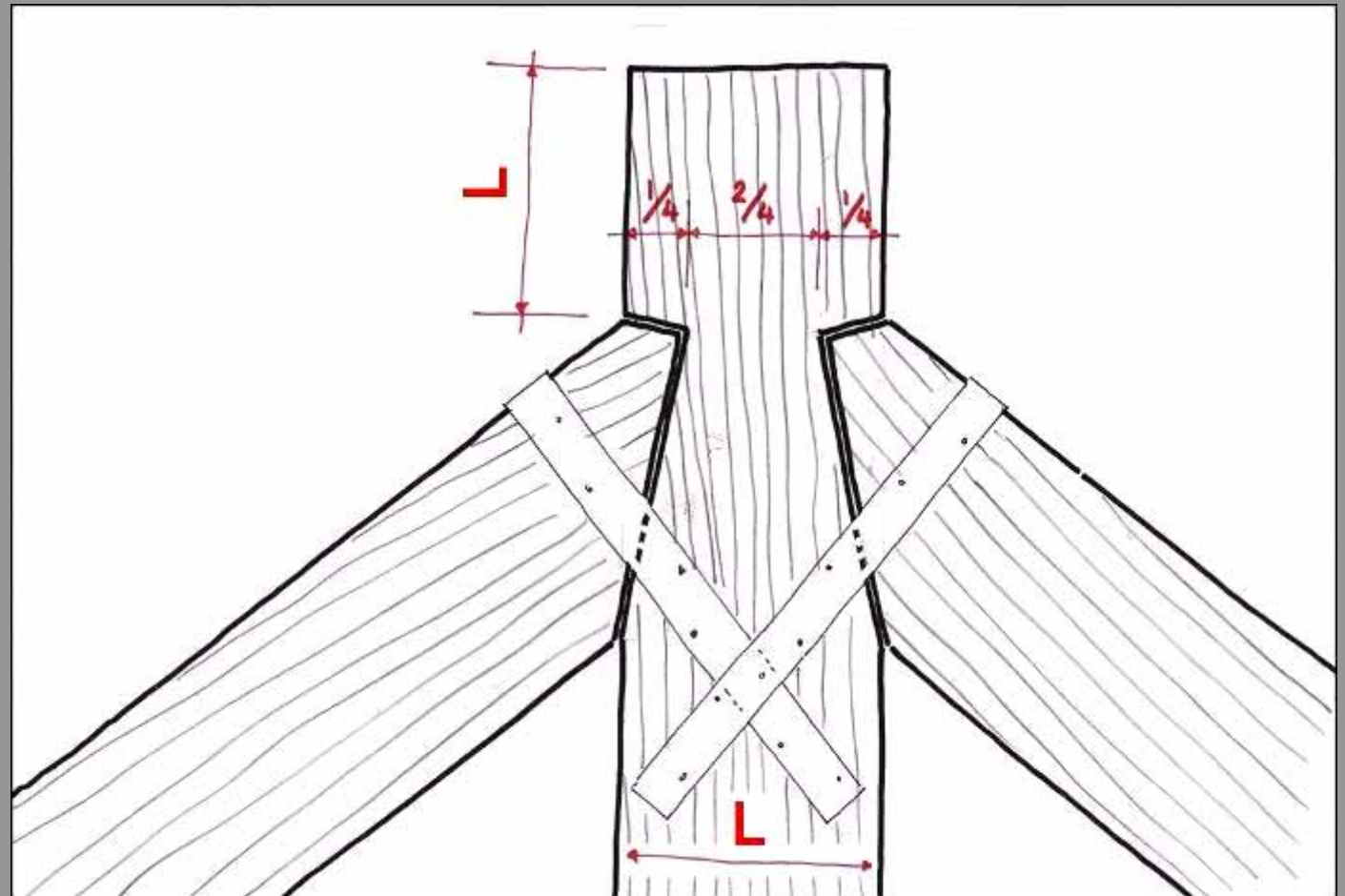

King-post

- A king-post does NOT stand on the tie-beam.
- But it can be used to suspend the tie-beam if this one is very long.

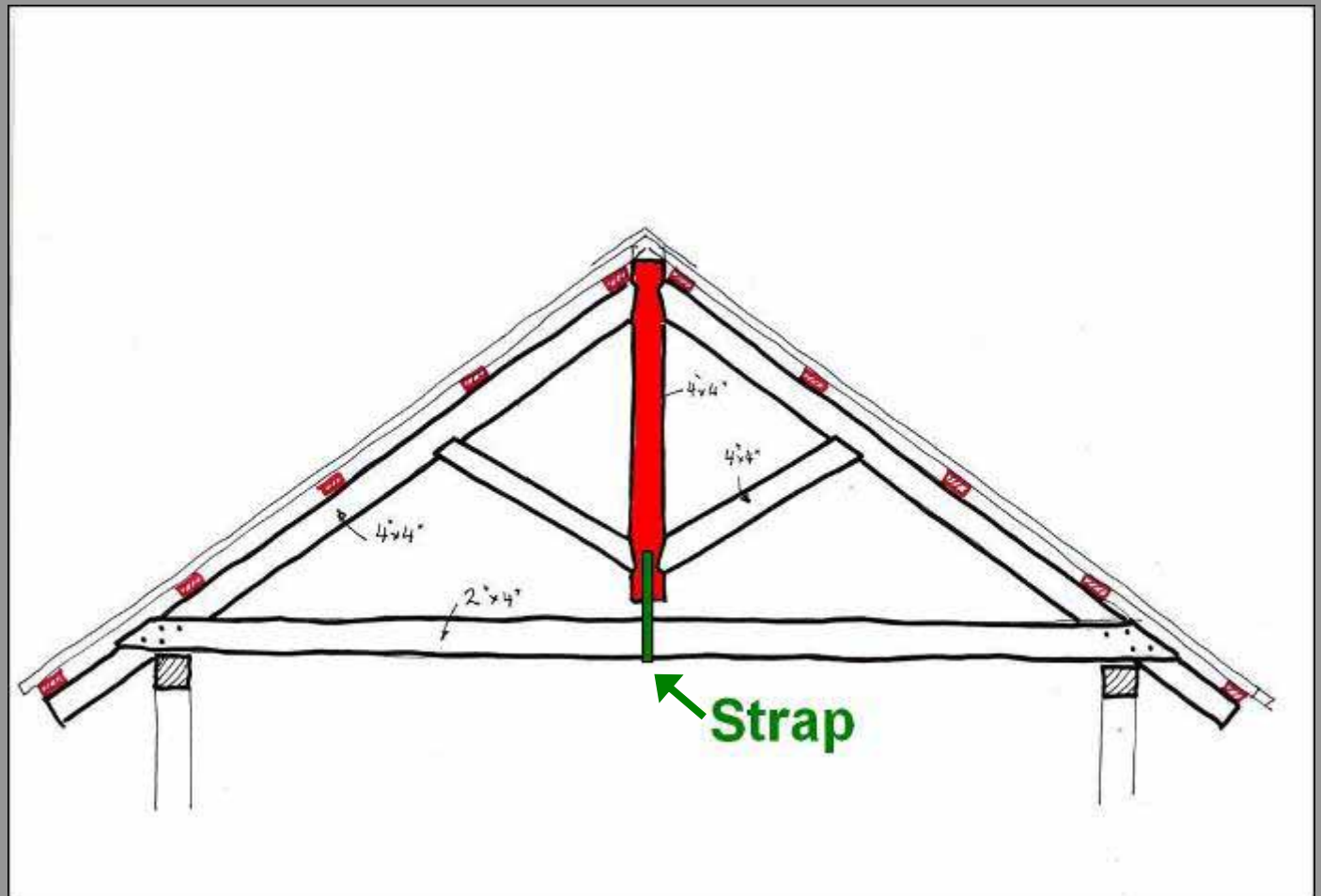

Additional truss details

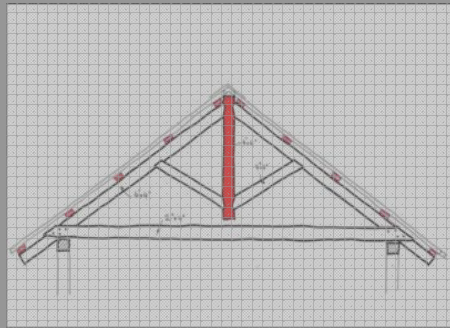

King-post

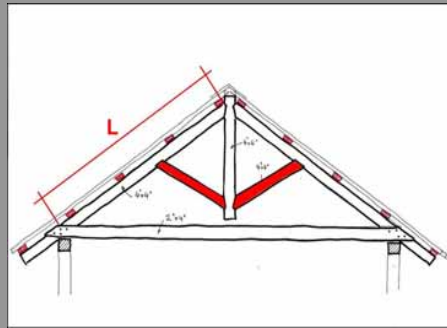

Braces

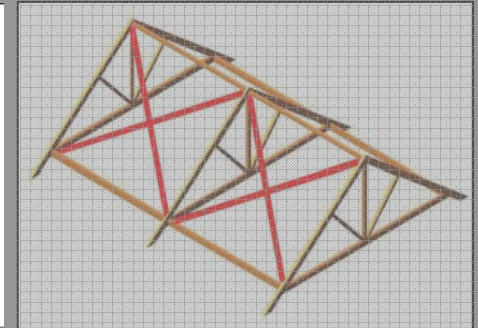

Cross braces

Braces

- You only need bracings if the length **L** of the rafter between the joints is longer than **10 feet**.

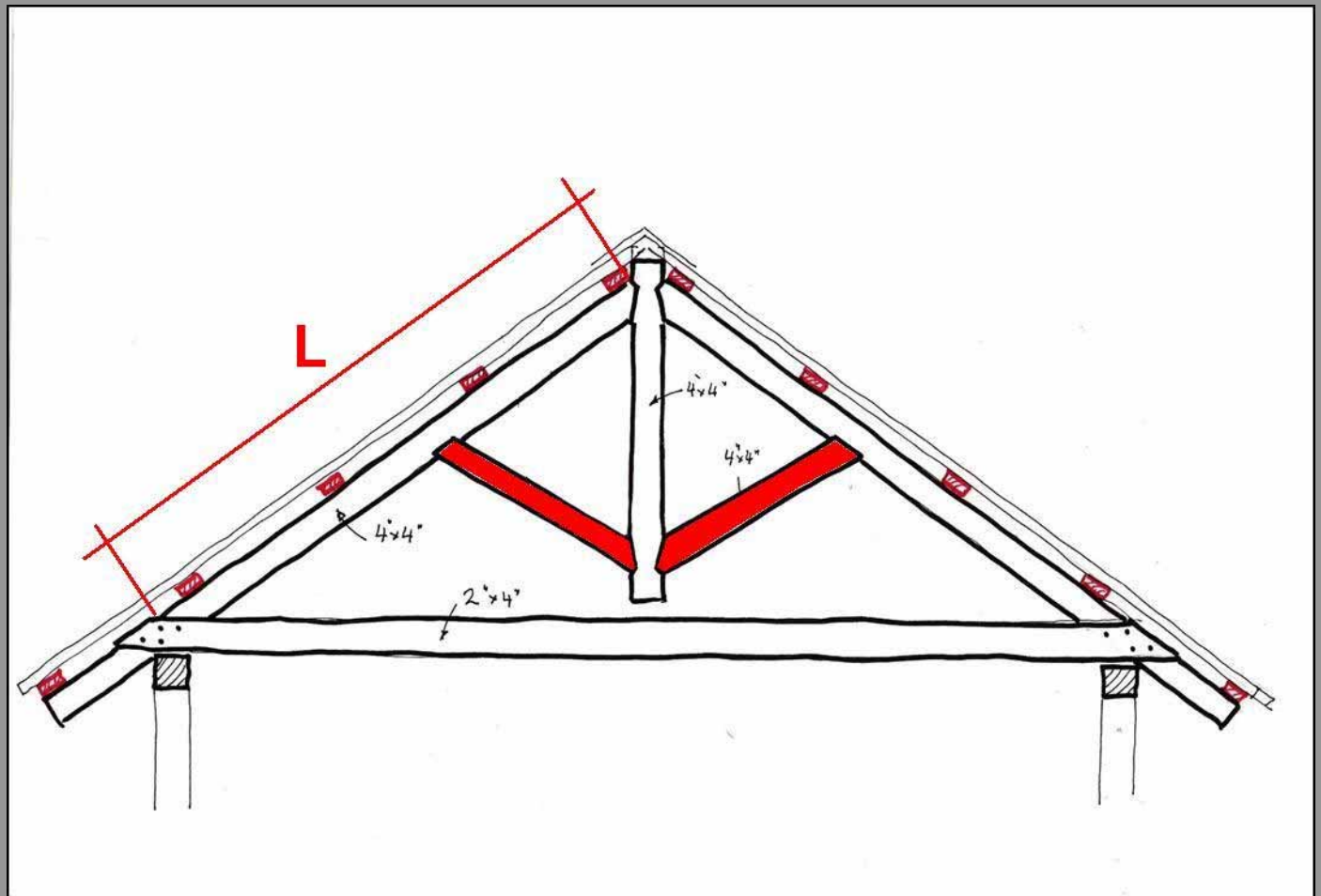

Braces

- If **L** is shorter, you can make a short king-post and secure it with two lateral boards.

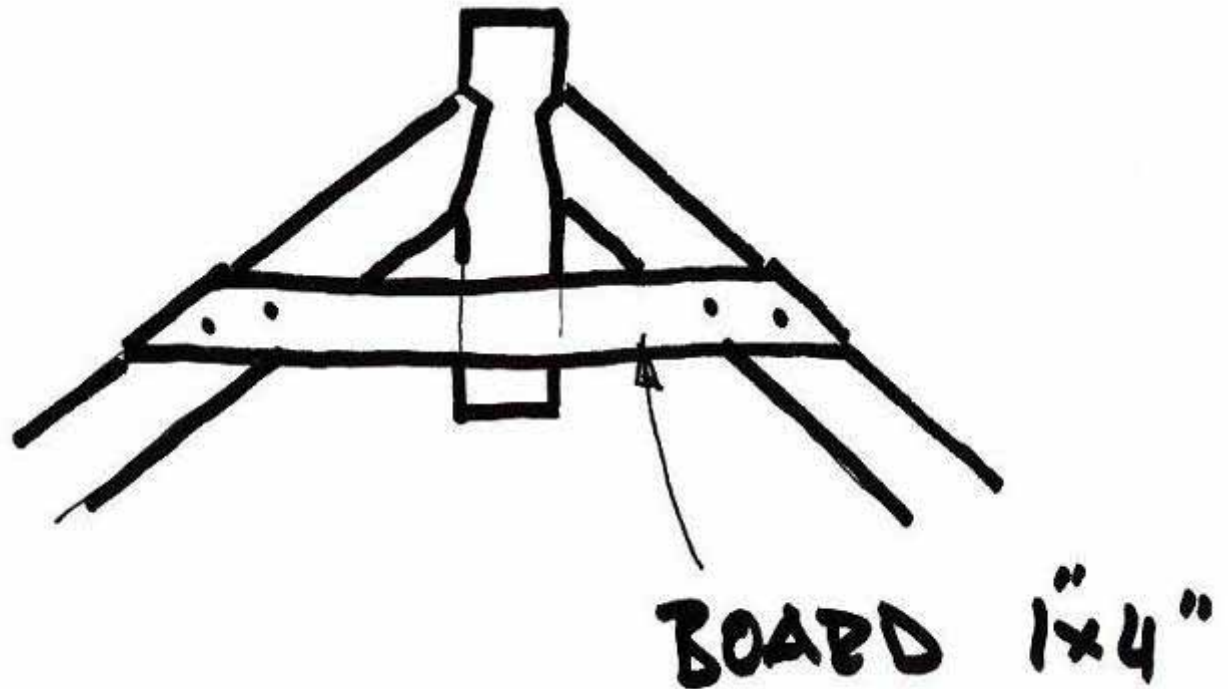

Additional truss details

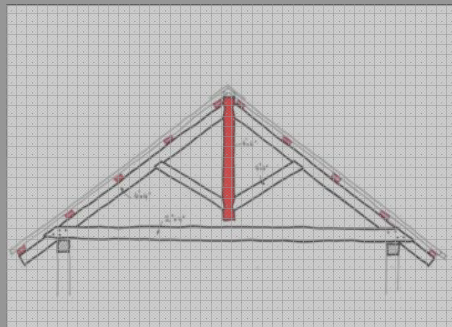

King-post

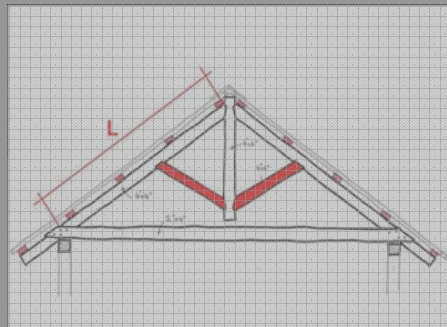

Braces

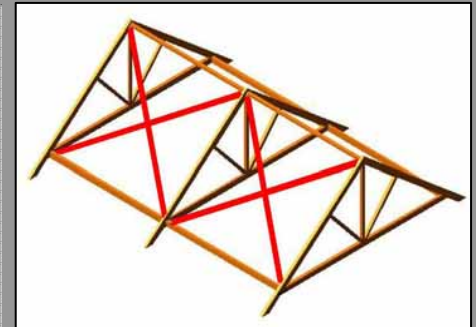

Cross braces

- Gable roofs must be braced with diagonal bracings.

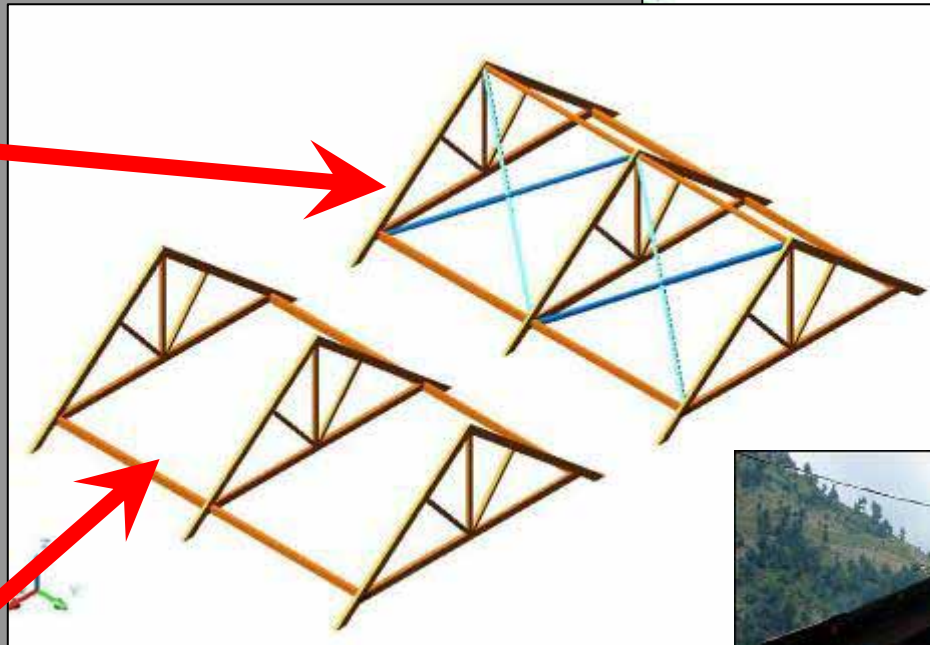
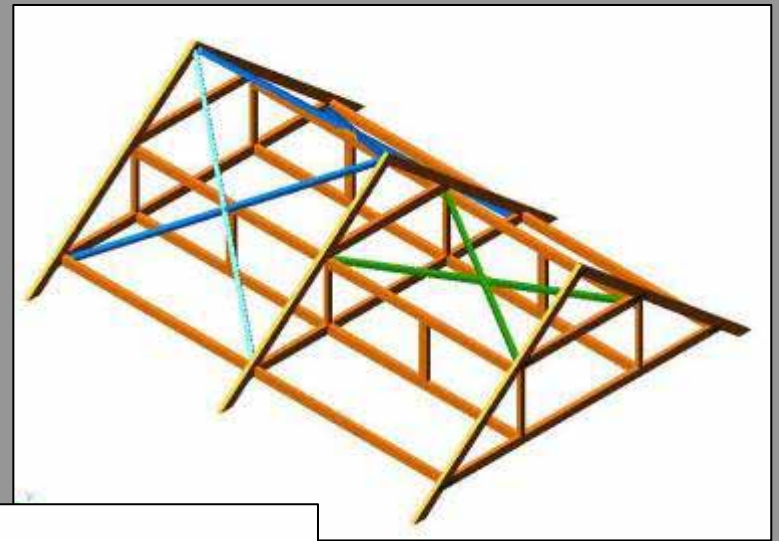

- Like this they would just fall over.



- Hipped roofs don't have this problem.
- Why?



And finally:

- Place the trusses on top of the posts.

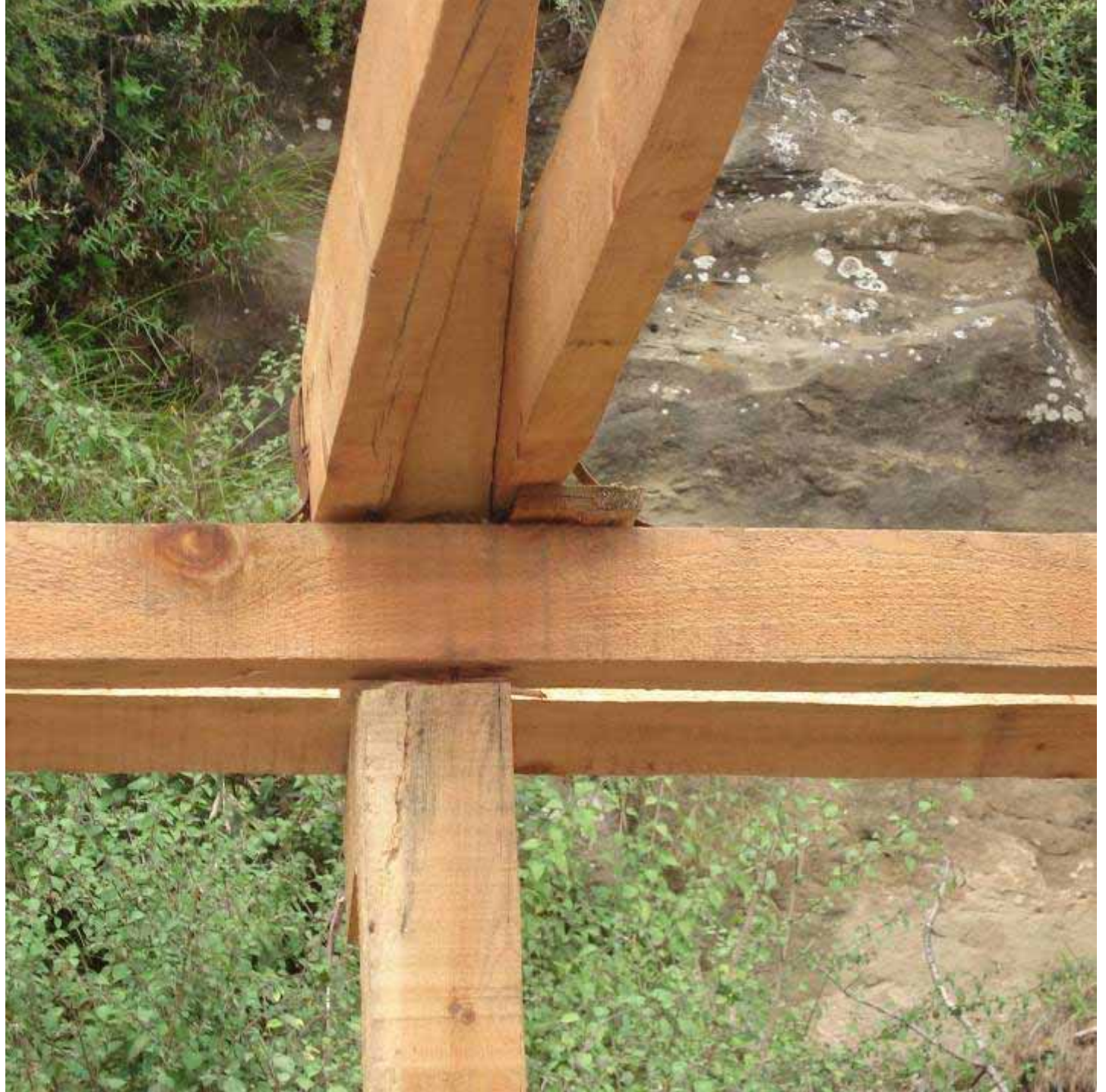

- Error:
Roof truss
not on top of
the columns.





7. Walls and bracings

- Fill the walls with diagonal pieces of wood (1" to 2" thick).



- Walls can be subdivided in small panels in many ways...

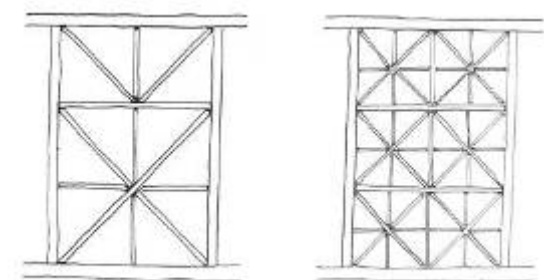
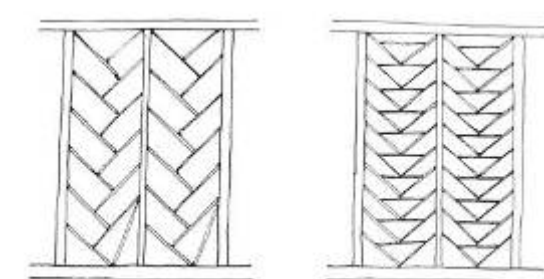
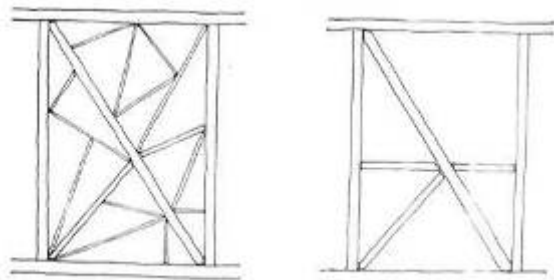
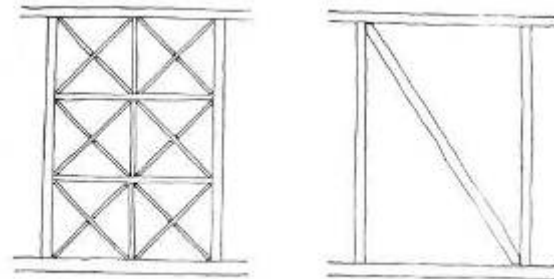
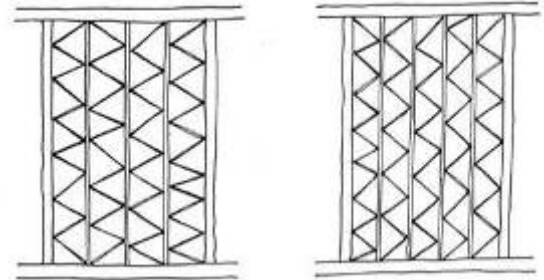
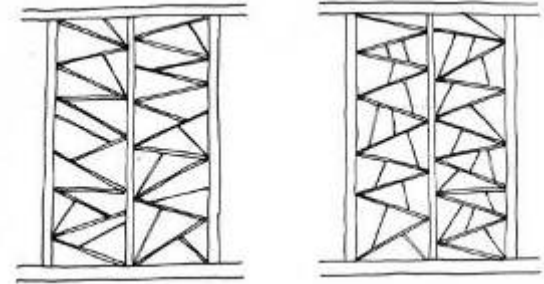

- Like this...

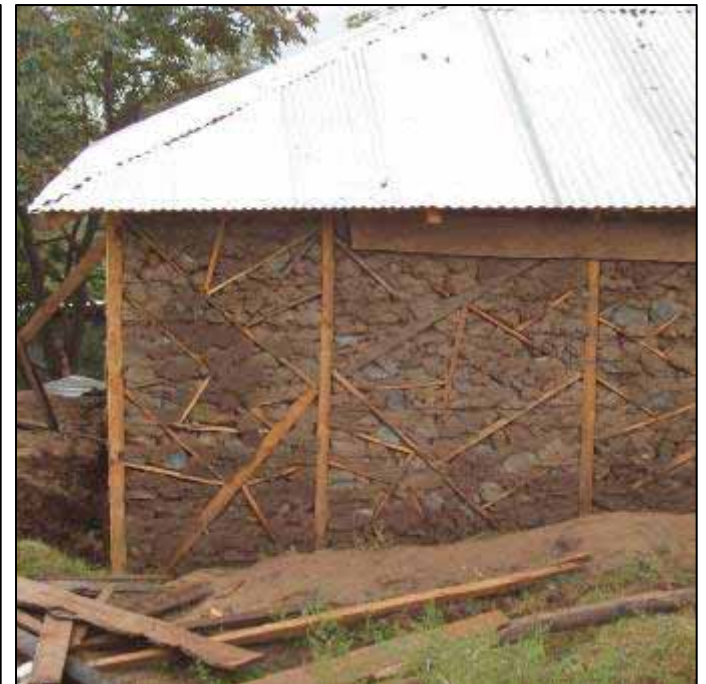
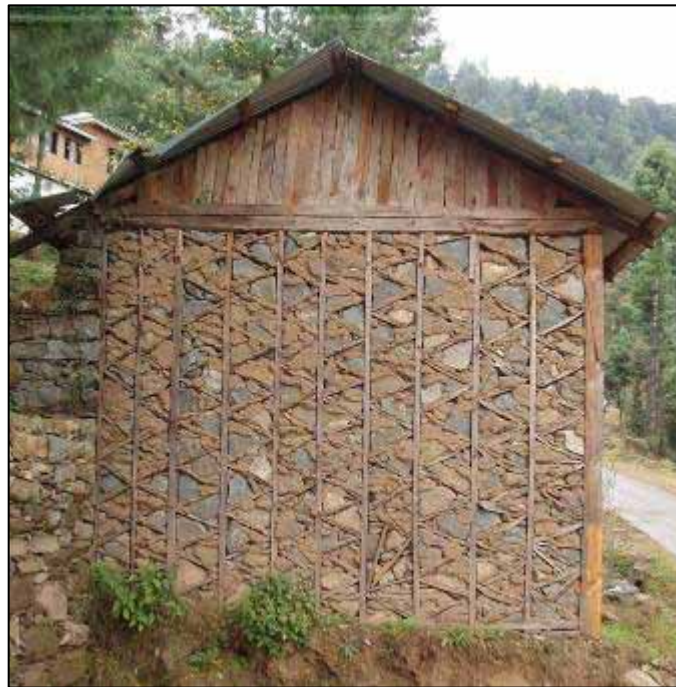

- Or like this...



... but not like this.

- Diagonals are too strong.
- Panels are too big.
- Connection with the posts is insufficient.
- No dasa.



- Nail the diagonal pieces well to the posts, with 3" to 4" nails, so that they don't get pulled out during an earthquake.

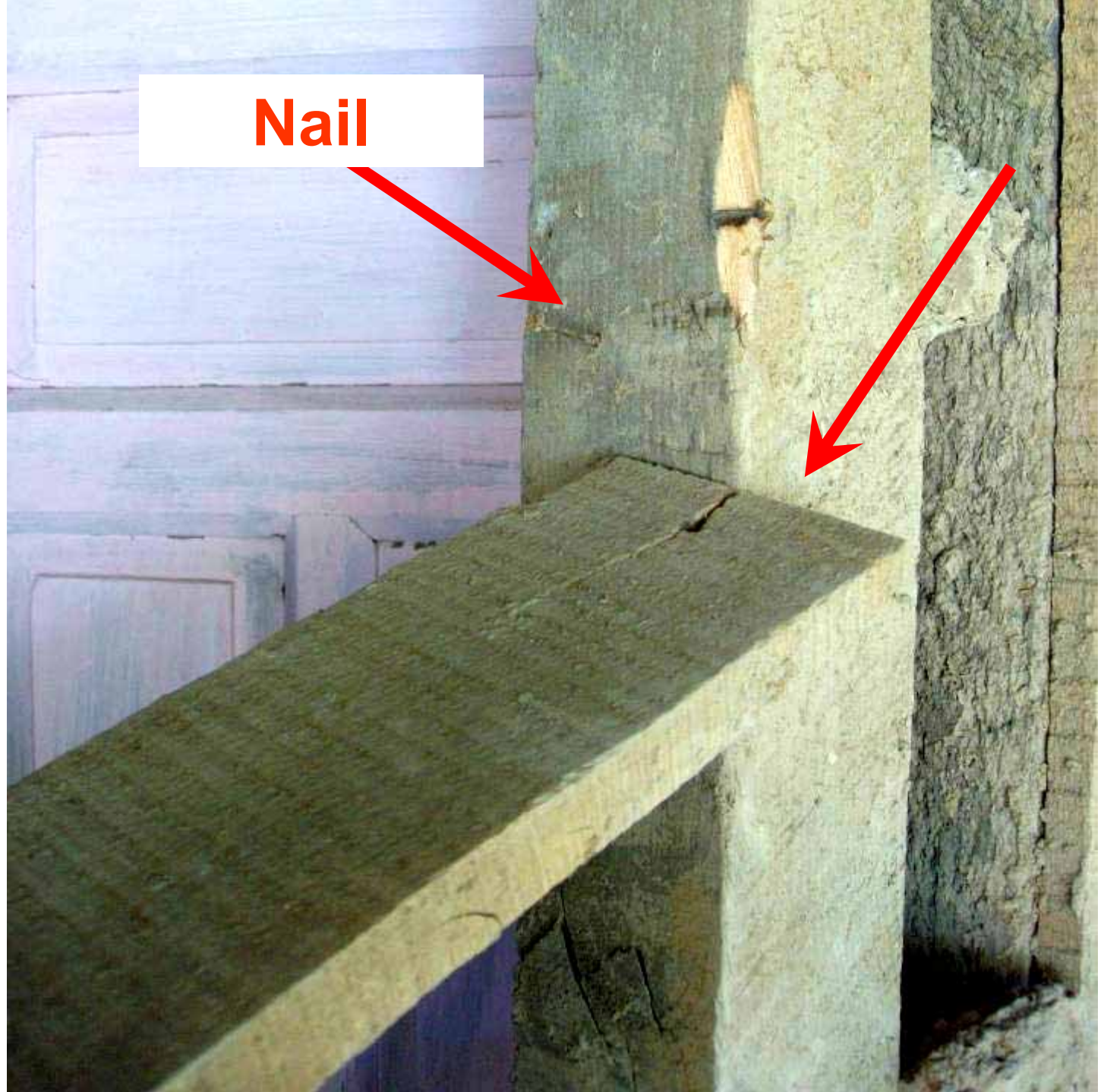

- Diagonal pieces were not well nailed to the posts.





8. Windows and doors

- A well placed window between main posts.



- Don't place too many openings in the same wall.
- It's the walls that make the house resist an earthquake, not the windows.



- Windows must be placed 2 ft away from the corners.
- They must be spaced at 2 ft away from each other.





9. In-fills and plaster



Why is mud mortar better than concrete?

- A cement – sand infill makes the wall too rigid.
- The small panels cannot move individually and absorb the energy.
- Mud mortar is much more effective.
- Pine needles and straw can be added to make the mortar more elastic.
- The mortar must be the same throughout the whole building.

- Fill in the spaces with stone and mud mortar.



- Stones must not be too big. Small stones are better.

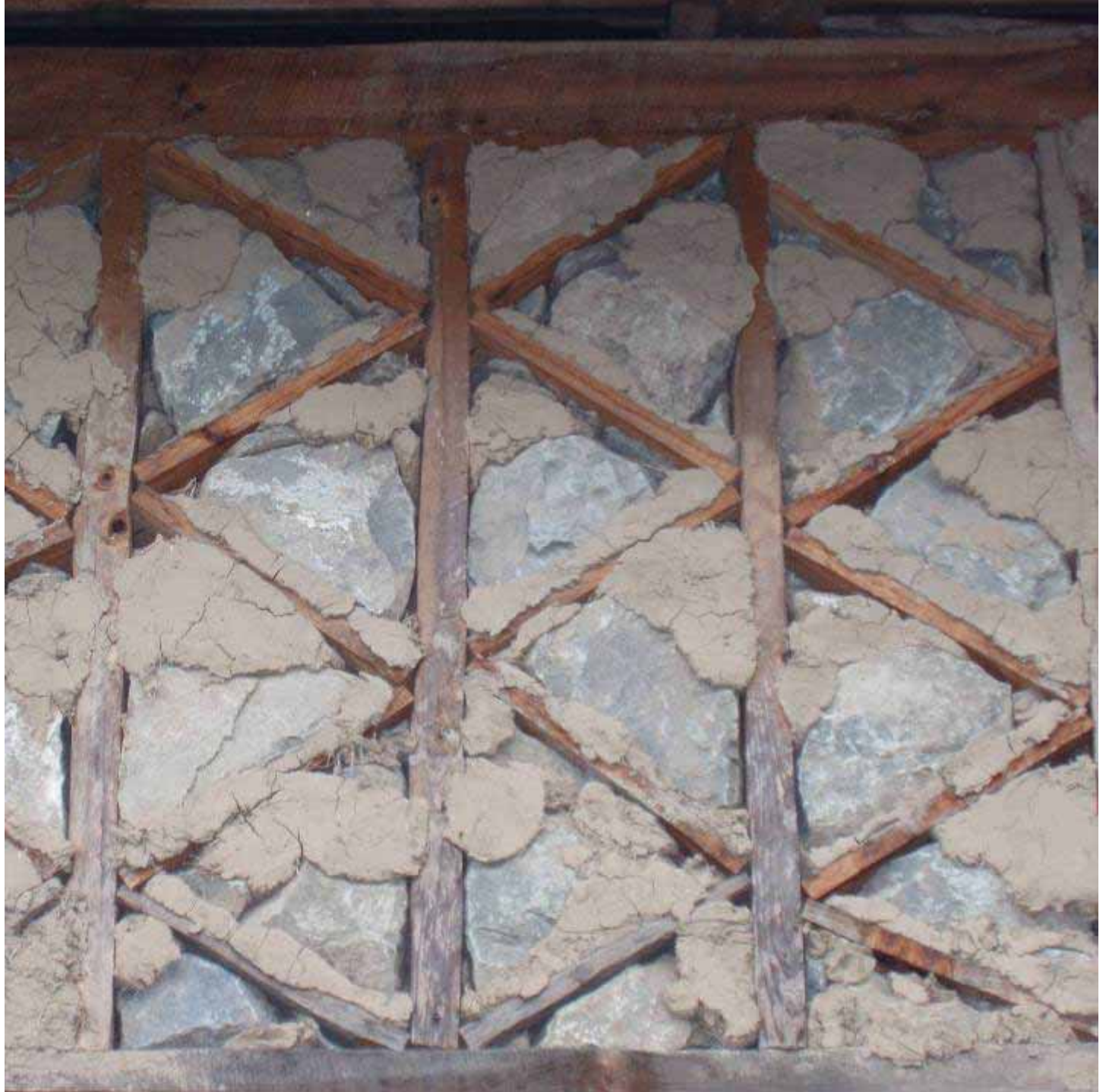

- These stones are also too big.
- The mud infill is insufficient.



- Perfectly shaped stones for the infills are less good than irregular ones.



- You can add straw or pine needles to the mud mortar to make it more resistant.



- Plaster the walls with mud containing straw (for more strength).

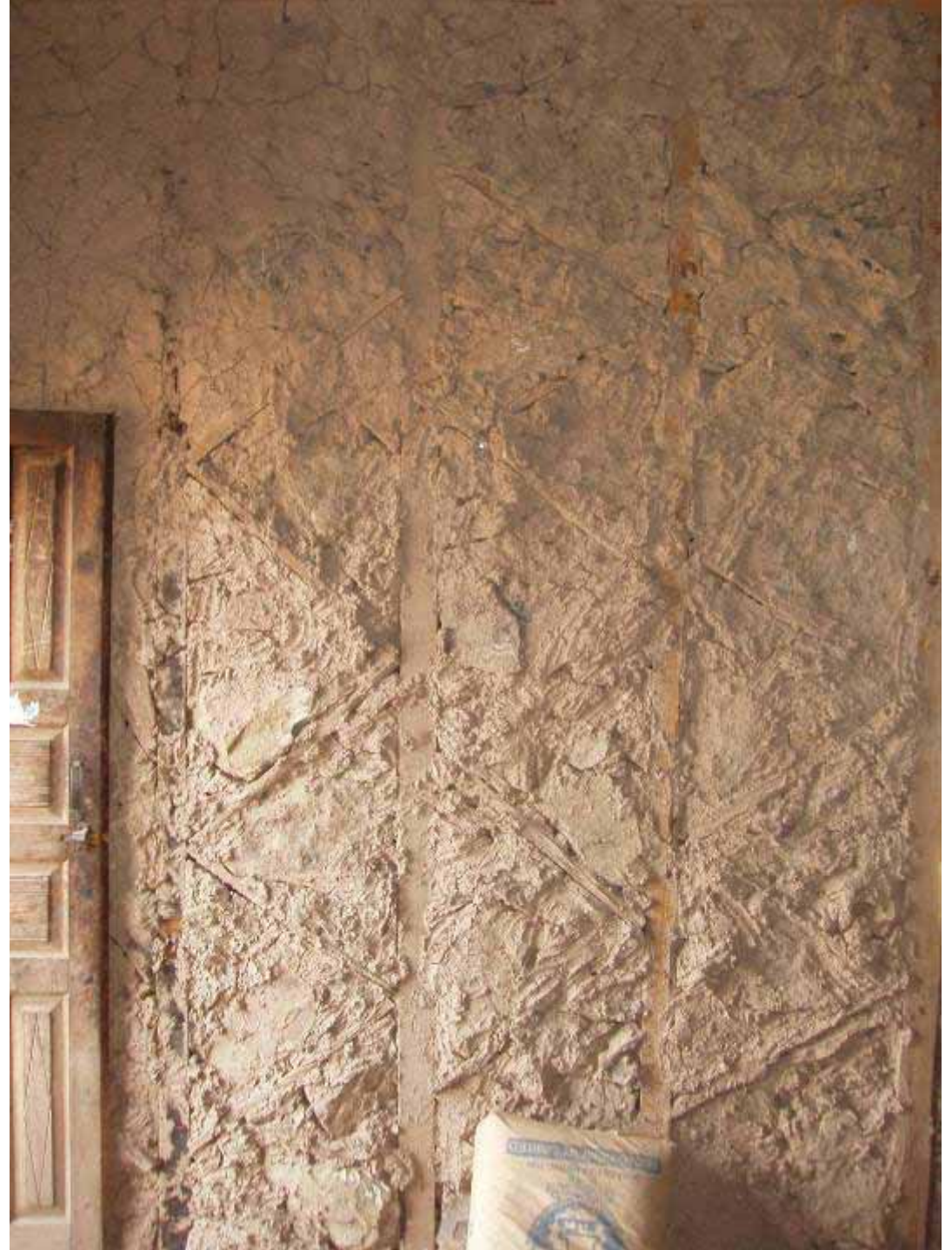

- Finish the wall with a nice mud plaster.
- Don't use cement, as it will break off quickly.

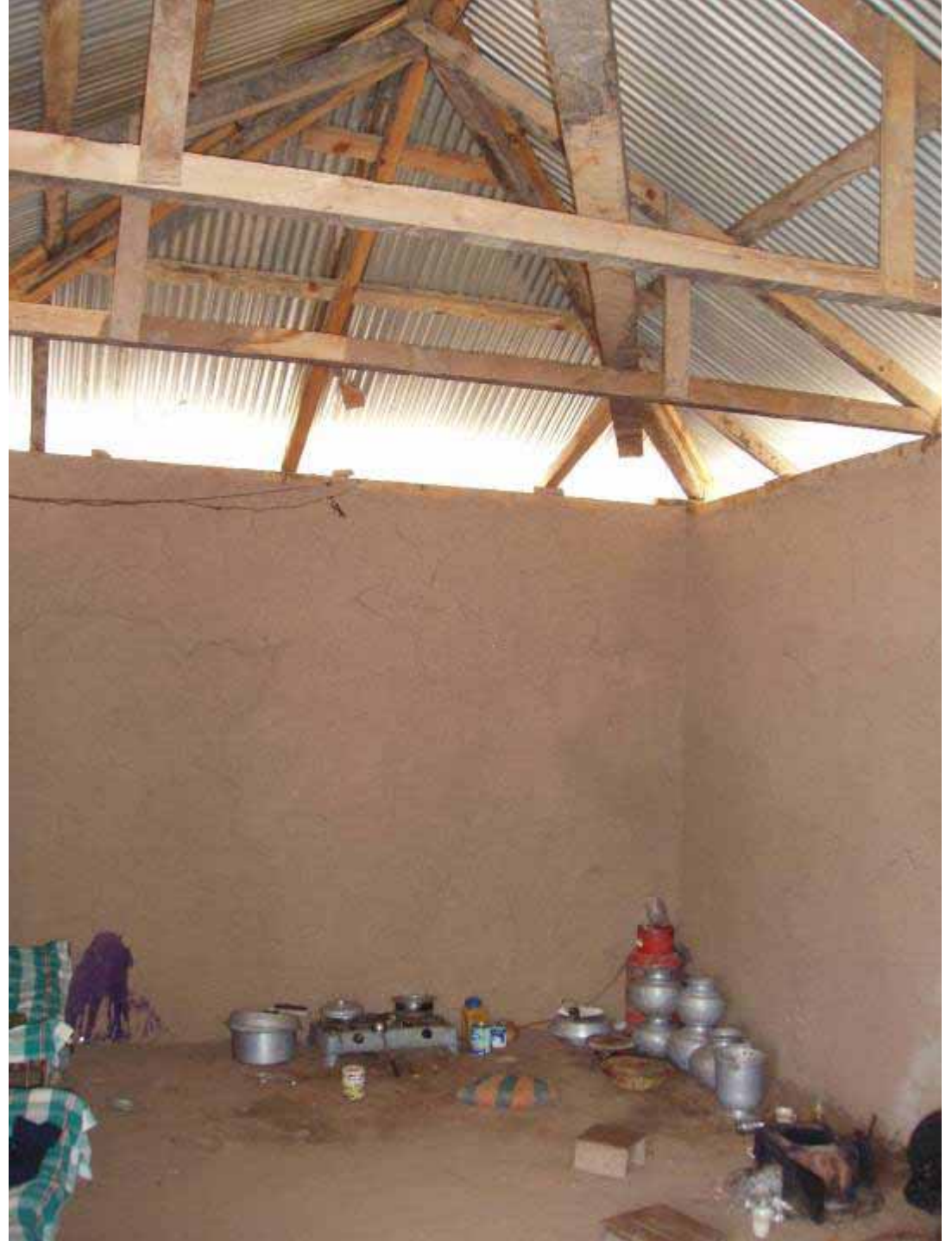



10. Examples

- A one room house requiring 60 cft of timber
- Examples from other countries



One room house

Material requirement:

- Timber: 63-69 cft
- Stone: 320 cft
- CGI sheets: 340 sft + 58 rft
- Cement: 30 bags
- Sand: 35 cft
- Door 3.5'x7': 1 pce
- Windows 4x4': 2 pieces

Stone requirement

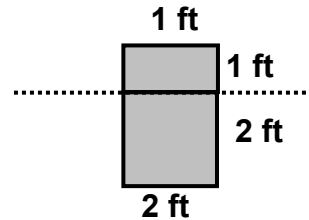

Foundation: 250 cft
Infills (-20%): 70 cft
Total: 320 cft

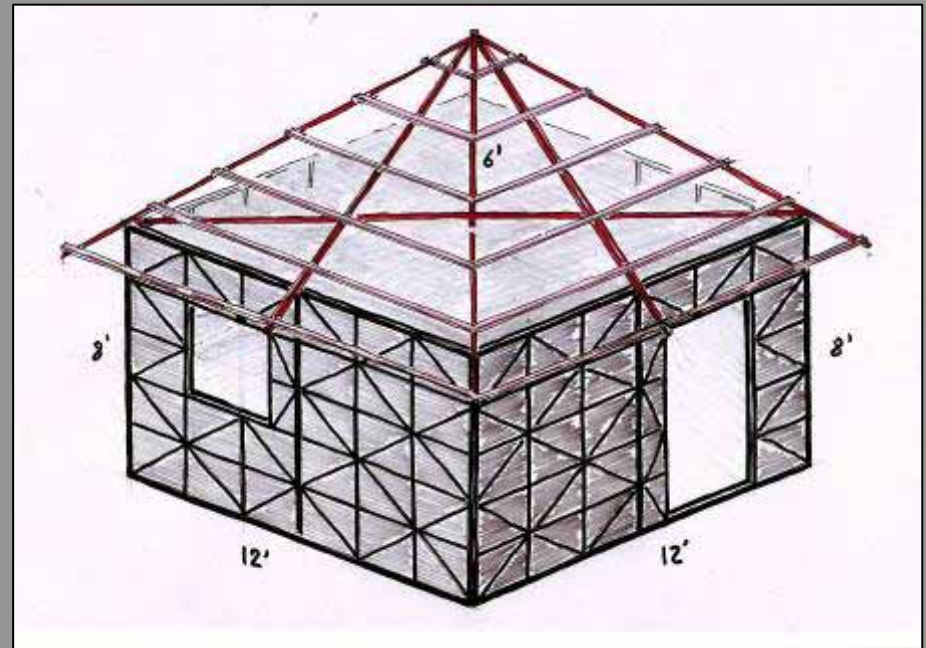

	Timber elements	Quantity			Length Feet	Total length		
		1"x4"	2"x4"	4"x4"		1"x4"	2"x4"	4"x4"
1	Main posts			8	8'			64'
2	Secondary posts		16		8'		128'	
3	Horizontal boards		96		1 3/4'		168'	
4	Diagonal boards	120			2 1/2"	300'		
5	Plates (dasa)			8	13'			104'
6	Main diagonal rafter			4	11 3/4'			47'
7	Rafters			4	9 1/4'			37'
8	Diagonal tie beam double		4		17'		68'	
9	Purlins		10		12'		120'	
Total linear feet						300'	484'	252'
						: 36	: 18	: 9
						8 cft	27 cft	28 cft
Total cubic feet						Approximately 63 cft		

From other countries

1. England
2. Turkey
3. Turkey
4. Switzerland
5. Germany





- Old house in Switzerland





Lesson prepared by

- UN Habitat (Maggie Stephenson)
- SDC (Tom Schacher)

Pictures by:

- UN Habitat:
 - Maggie Stephenson
 - Habib Mughal
 - KIRS
- SDC:
 - Tom Schacher
 - Khalid Sardar

Mansehra, Pakistan

13 December 2006