



Disaster Resistant Construction Practices

A Reference Manual

Natural Disasters in Tamilnadu



The Aftermath

- Loss of Human and animal lives
- Economic loss in terms of damages to crops and infrastructure
- Loss of livelihood
- Damage to housing and habitat

Unsafe Buildings Kill People

- Improper location
- Faulty design, use of poor quality materials
- Sub-standard construction practices
- Non-compliance to building codes
- Lack of awareness of:
 - Safe Construction practices
 - Disaster resistant practices



Introduction

Disaster Resistant construction practices are as important as disaster resistant structural designs. Infact the methodology for construction also should be designed for disaster resistance. We should have proper implemenation of the structural details so as to let the structure behave as envisaged.

The quality and methodology of construction is equally important. For example we use cover blocks. If the cover blocks are not cast properly in good quality concrete then they facilitate concrete deterioration. Ultimately this affects durability and serviceability of the structure.

The Durability and serviceability are the key elements of any structure. Ensuring Quality in construction will enable achieving durability and serviceability as a desired end result.

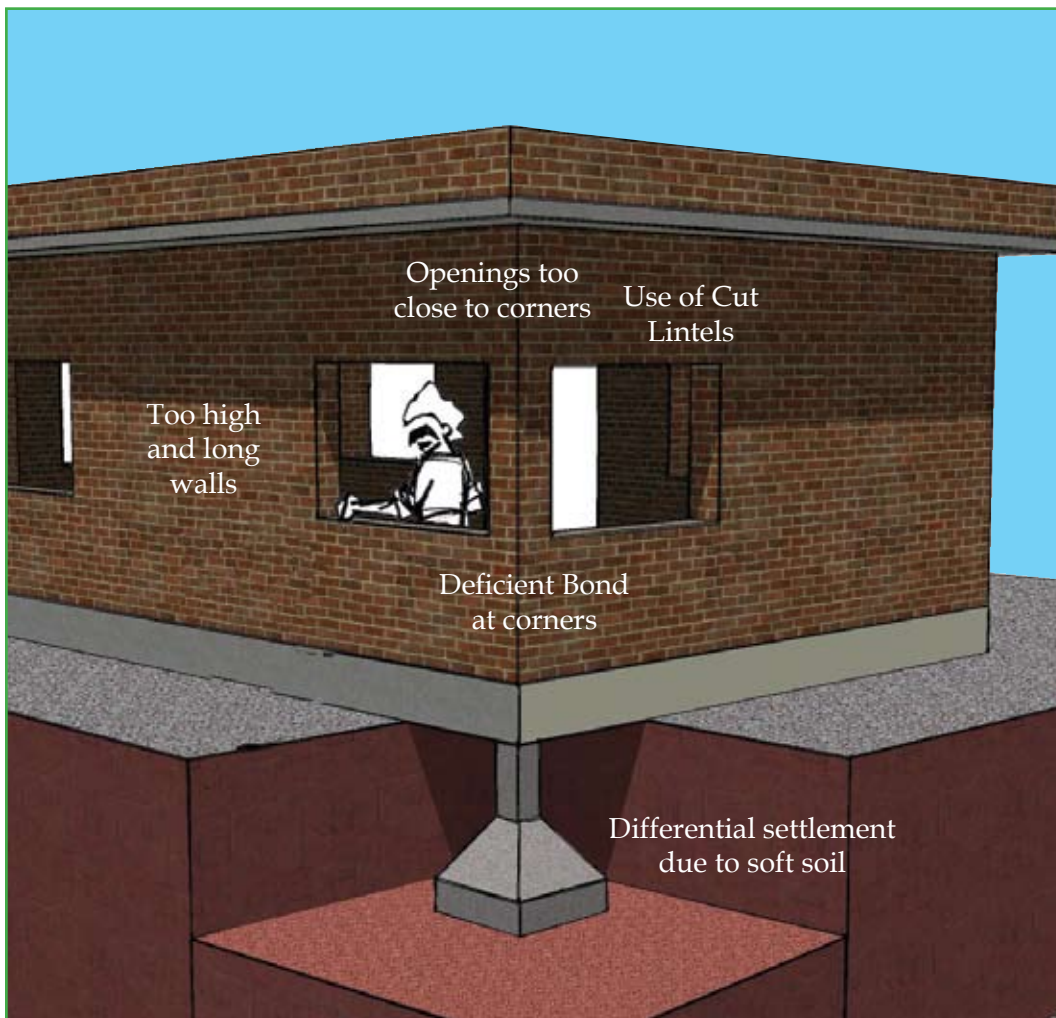

Usually a building comprises of:

1. Walls
2. Openings
3. Foundation
4. Plinth
5. Beams/Columns
6. Roof / Slabs

Parts of a Building

Vulnerable Parts of a Building

1.1 Settlement pattern and Design Considerations

PROVIDE

- Clustered (zigzag) planning avoids tunneling effect and reduces susceptibility to disaster

AVOID

- Row house settlement with roads leading to Sea

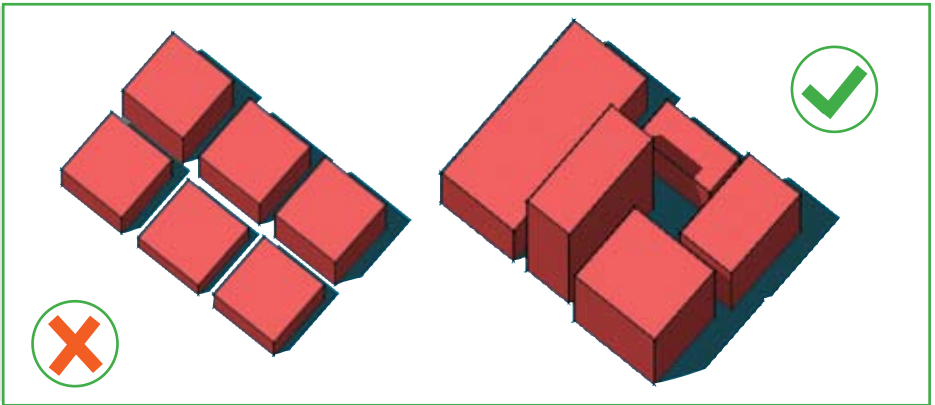

PROVIDE

- Simple Square/Rectangular and Symmetrical plan is Suitable
- Length of Building $\leq 2 \times$ Width

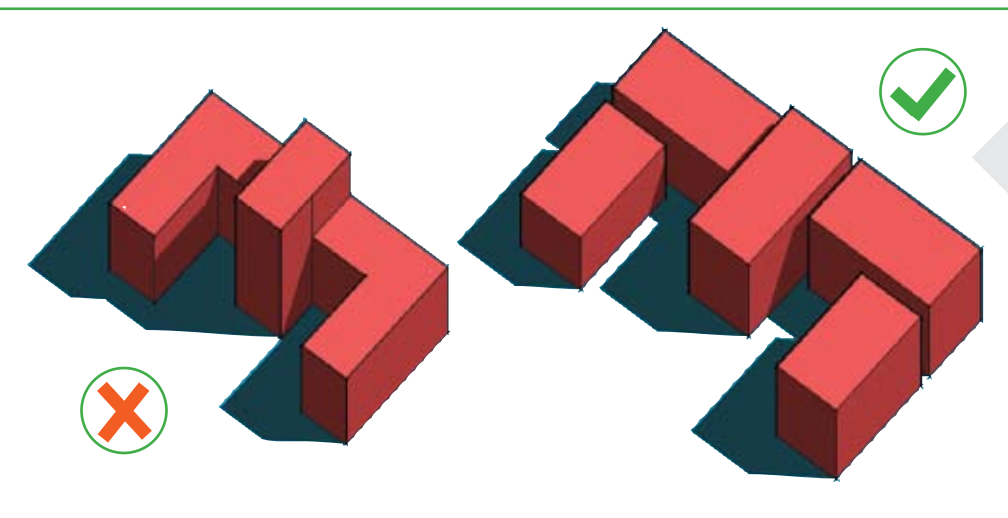
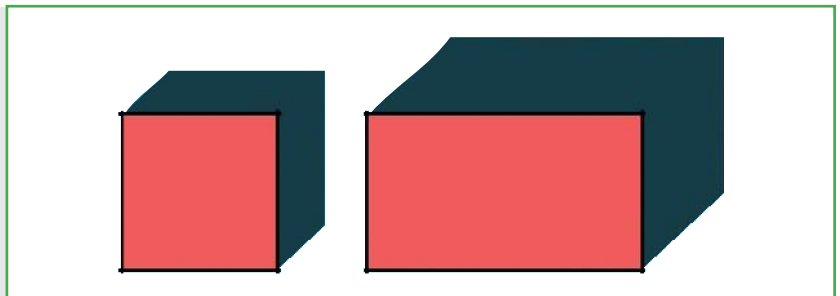

PROVIDE

- Separation of wings into different rectangles in plan is preferable

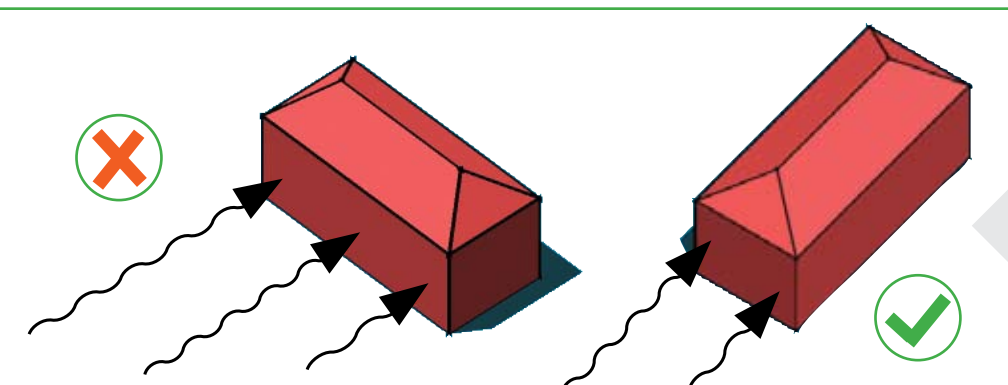

PROVIDE

- Shorter wall facing wind direction

AVOID

- Longer wall facing the direction of wind

Foundation 1.2

PROVIDE

- Slightly Slanting cut
- Sand Compaction thickness more than 150mm
- PCC thickness more than 75mm

AVOID

- Straight Cut
- Sand compaction less than 150mm
- PCC less than 75mm

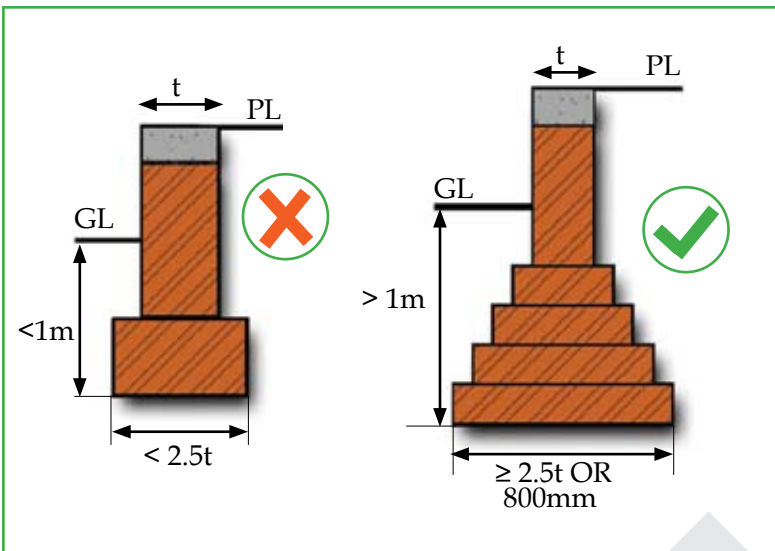
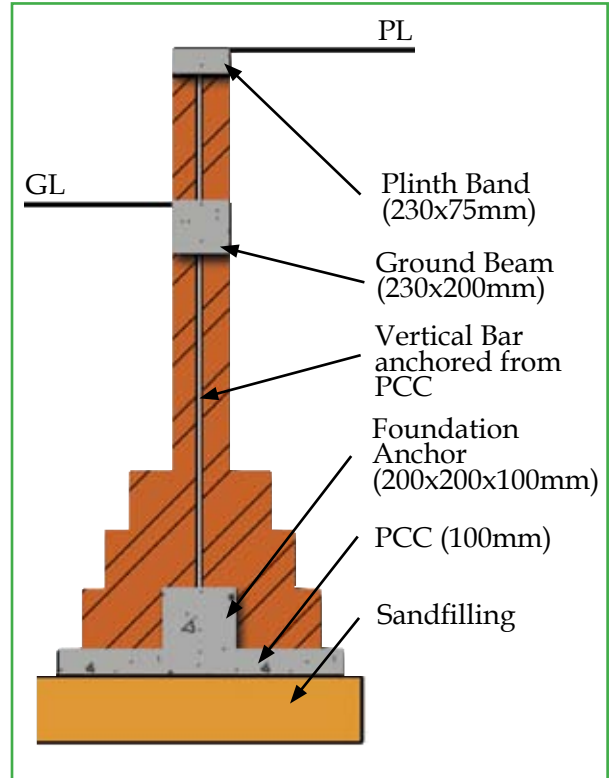
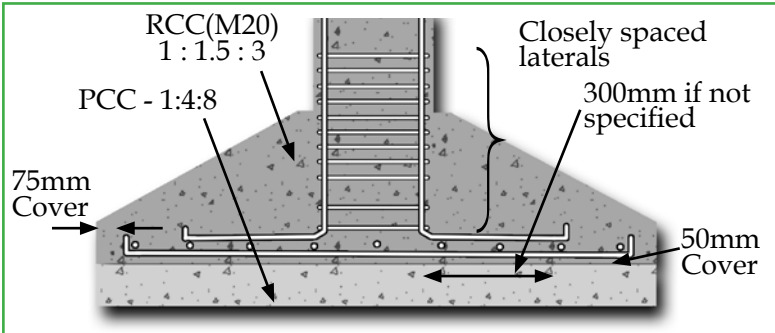
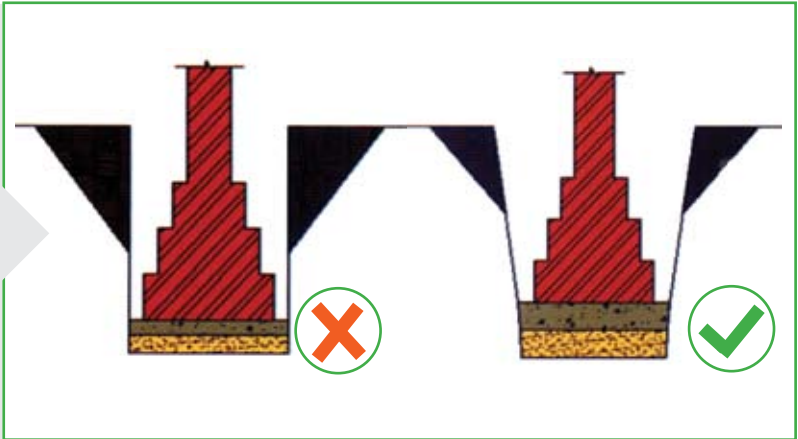

PROVIDE

- Foundation width should be $2\frac{1}{2}$ times thickness of the wall or 0.8m, whichever is more
- Use baked bricks and stones
- Minimum depth should be 1000mm

AVOID

- Foundation width should not be less than $2\frac{1}{2}$ times thickness of the wall
- Never make a wall without foundation
- Don't use unbaked bricks in the foundation

PROVIDE

- Foundation on Hard Soil

AVOID

- Foundation on Loose or Soft Soil

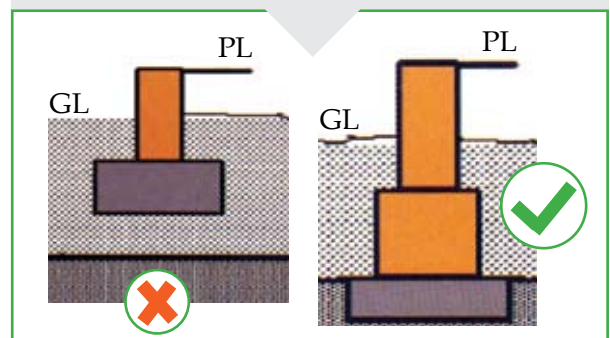

1.3 Walls

PROVIDE

- Average wall height should be 2700 to 3000mm

AVOID

- Too High Walls

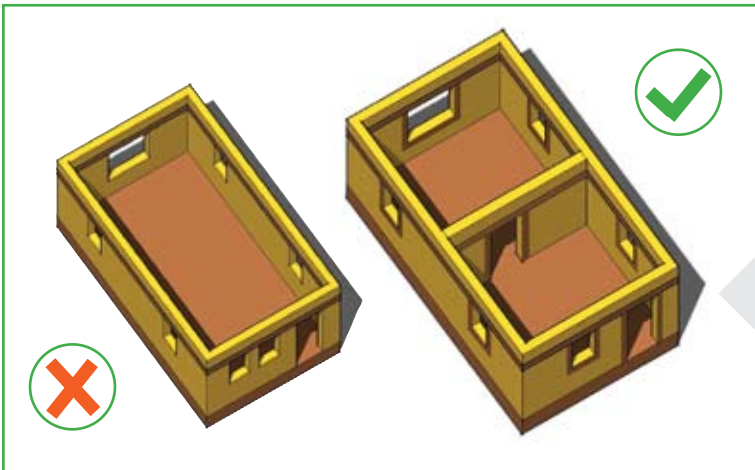
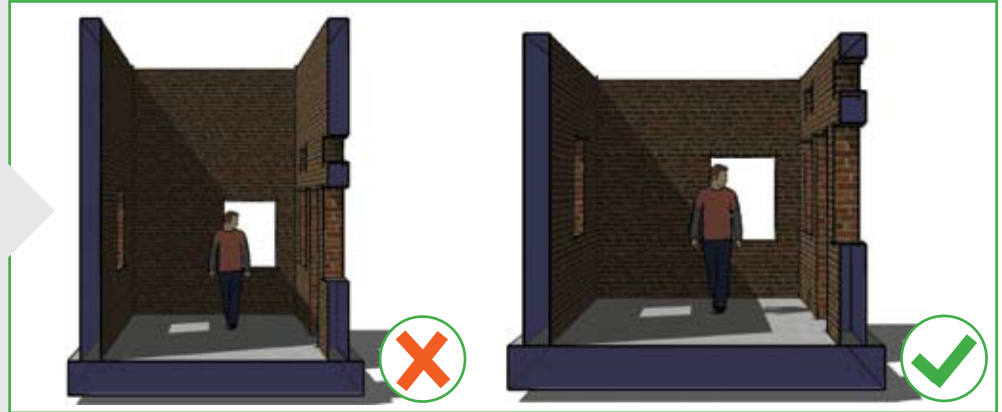

PROVIDE

- The length of the wall should not exceed 8 times the thickness
- Addition of a buttress wall reduces L/H Ratio

AVOID

- Walls that are too high or too long

Stone Masonry

A. Through stone should be placed horizontally at a minimum spacing of 1200mm center-to-center

B. Through stone should be placed vertically at a minimum-spacing of 600mm

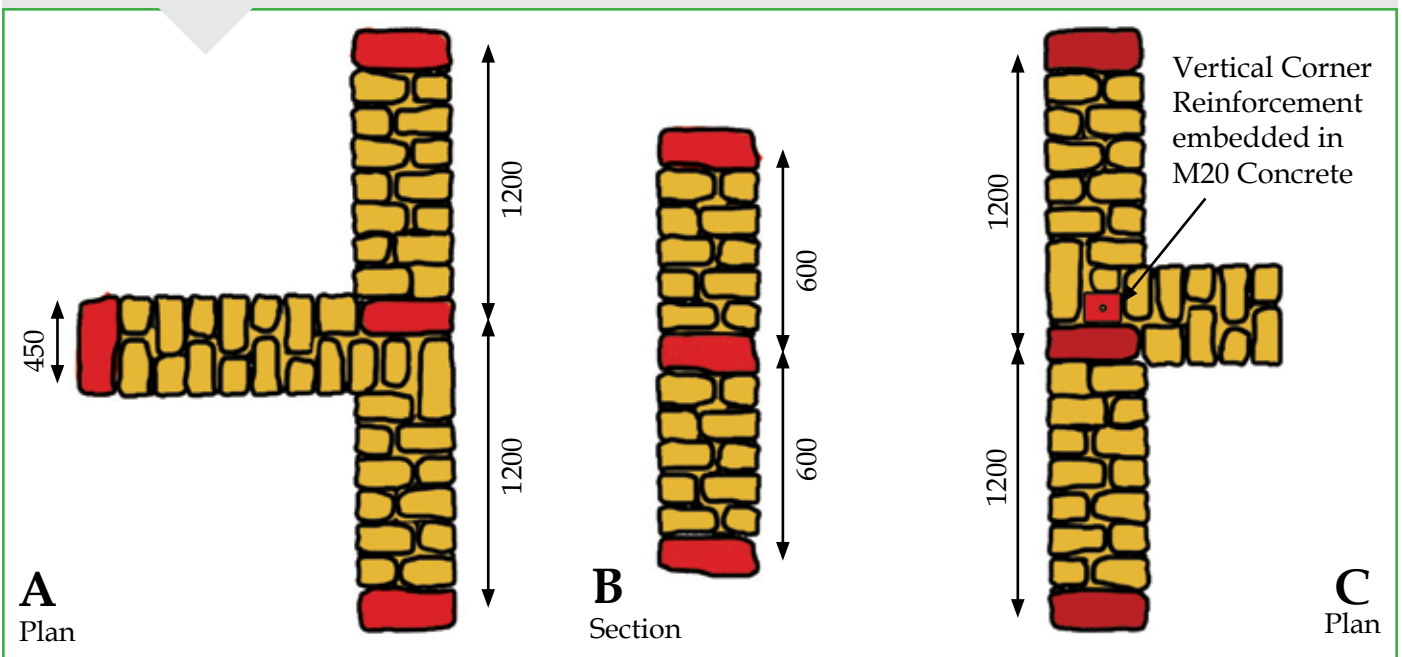

Walls 1.3

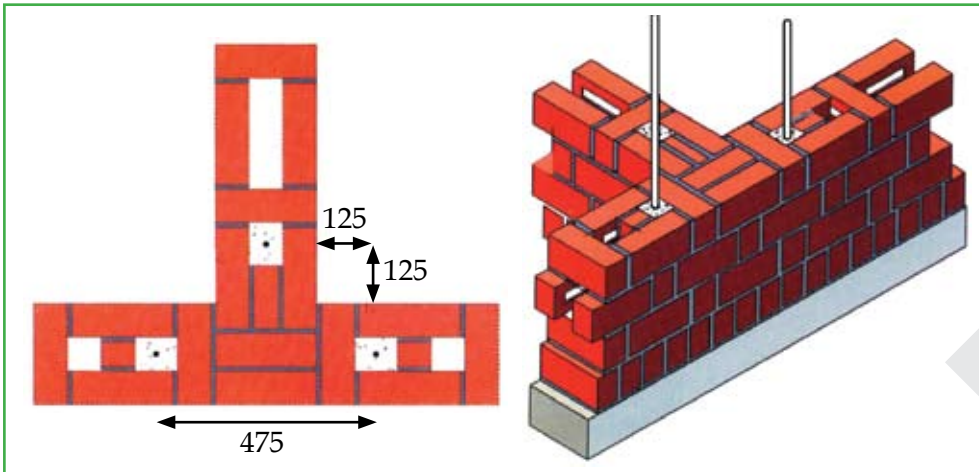

- Vertical Rod should be placed at 125mm from the inner face of the Brickwork

Rat-trap Bond (T-Joint)

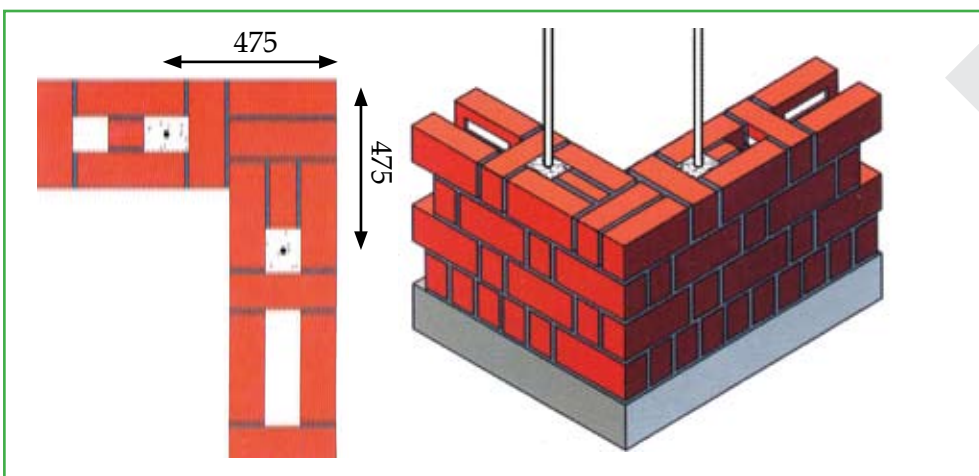

- Vertical Rod should be placed at 245mm from the inner face of the Brickwork

Rat-trap Bond (L-Joint)

Vertical rod must be connected using extra "L" bar with main steel of Plinth band and Lintel band. The bar will be able to perform efficiently if it is anchored at Foundation and Slab and linked with plinth and lintel band.

1. Joints in brickwork should be staggered.
2. For regular bond use only mortar of 1:6 or richer and for Rat - Trap bond 1:5 or richer.
3. Vertical rods should be protected with a minimum cover of 40mm in M20 concrete.

- Locate the vertical bar at 165 mm from the outer face of 230 mm wall

English Bond (L-Joint)

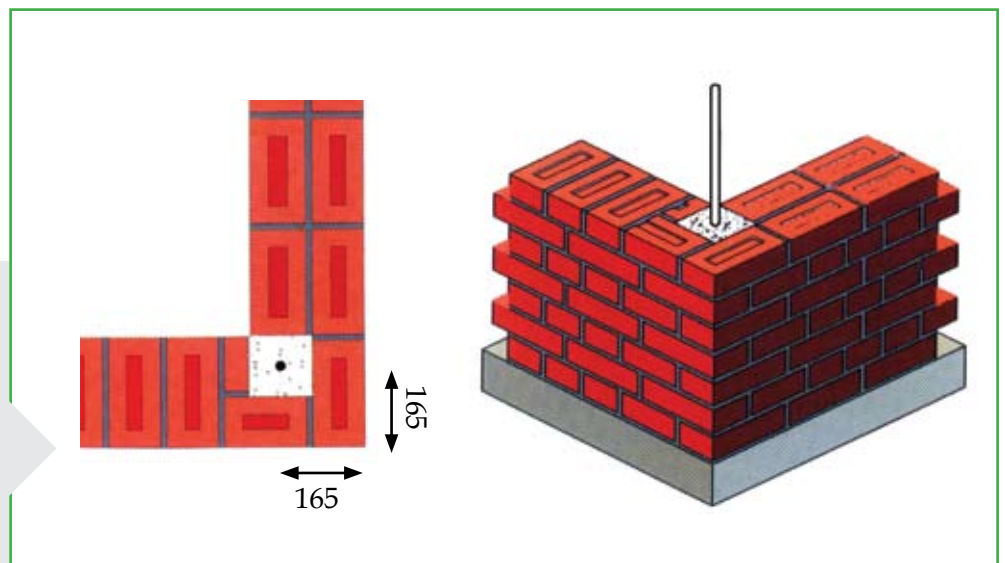

1.3 Walls

Sectional View of Disaster Resistant Wall

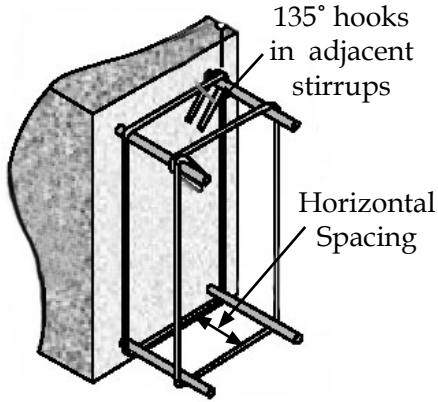

Reinforcement in Seismic Beams and Bands

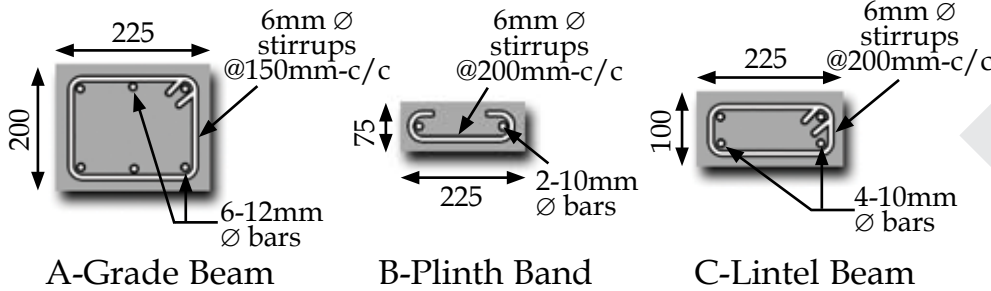
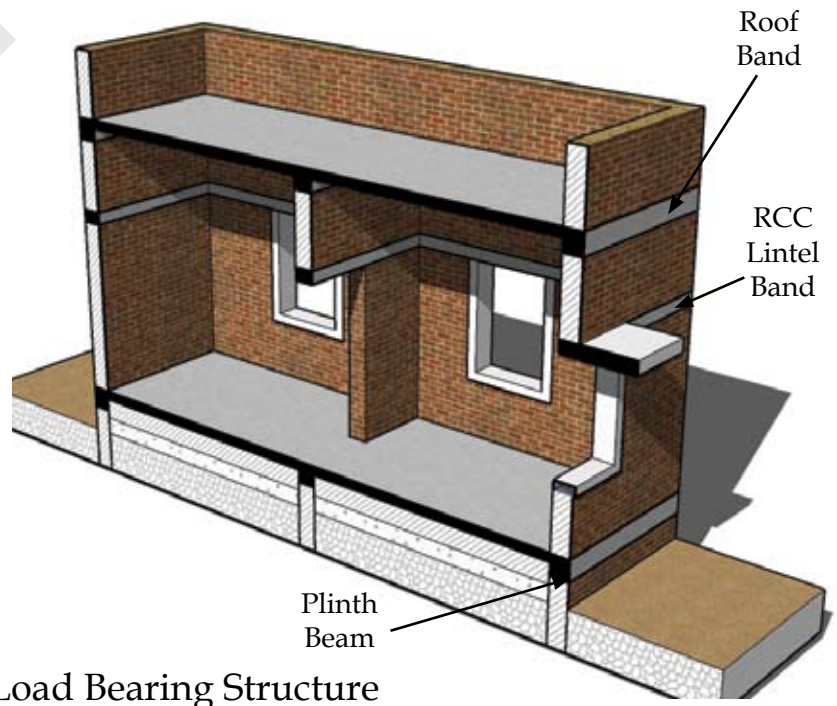

Disaster Resistant Beams and Bands in the Walls

- A. Grade Beam (In case of Frame)
- B. Plinth Band
- C. Lintel Beam

RCC Band Details

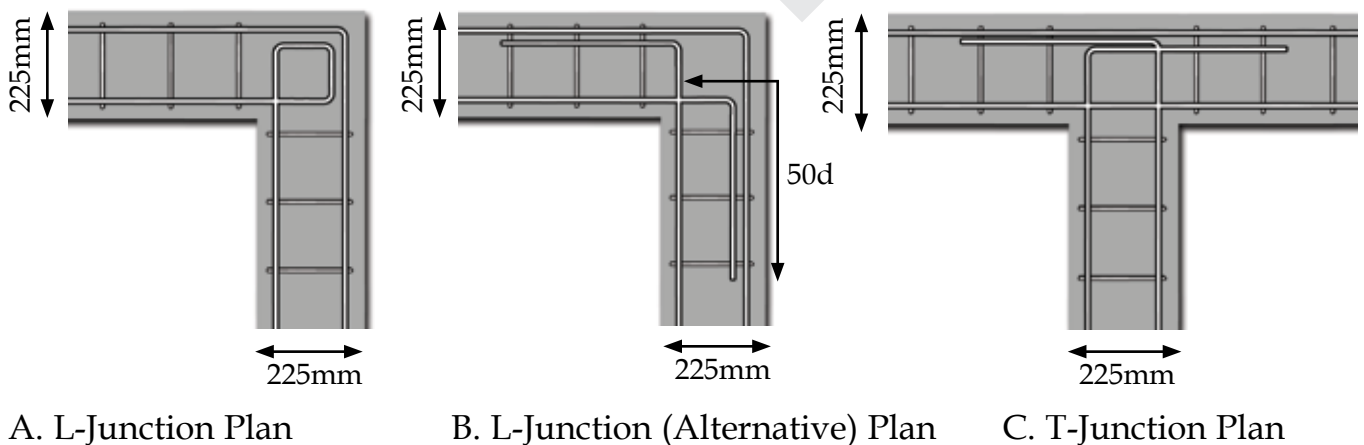

Openings 1.4

Openings are the most vulnerable part in a building. Large shear forces get accumulated around openings and therefore, edges of the openings should be specifically strengthened.

Due to lateral thrust openings are subjected to movements attempting to make them a Rhombus - stretching opposite diagonals as shown. Because of this it is likely that after an Earthquake; diagonal / shear cracks occur around unsecured openings and brick piers.

No Corner Reinforcement

- Diagonal Cracking in building with no Corner Reinforcement

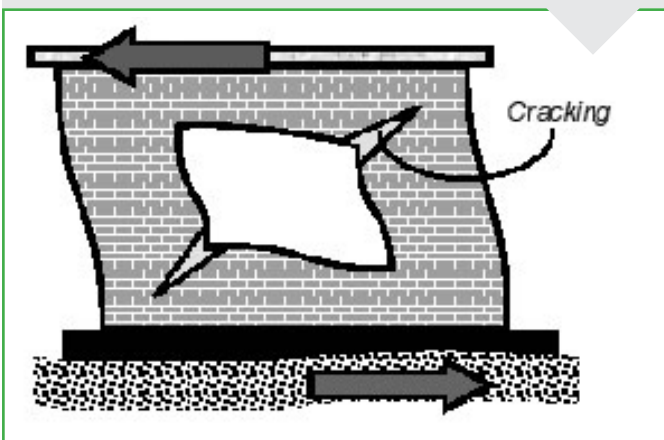

No Cracks in Buildings with Vertical Reinforcement

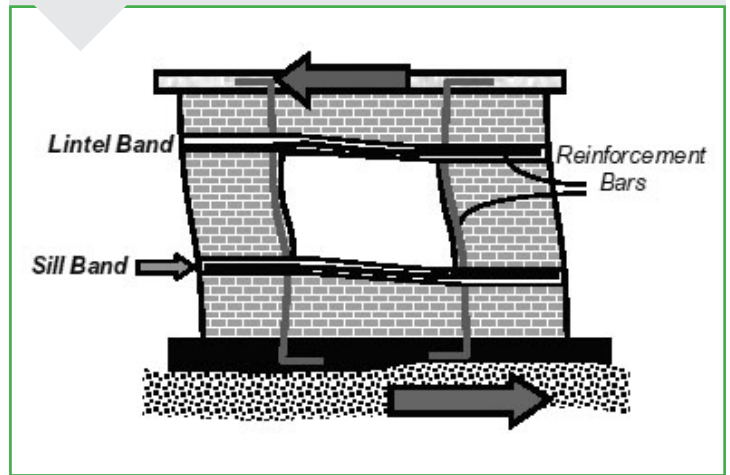

Protect Openings with Reinforced Band all around as shown. Detail of reinforcement is shown in cross-section of the Jamb at 't'

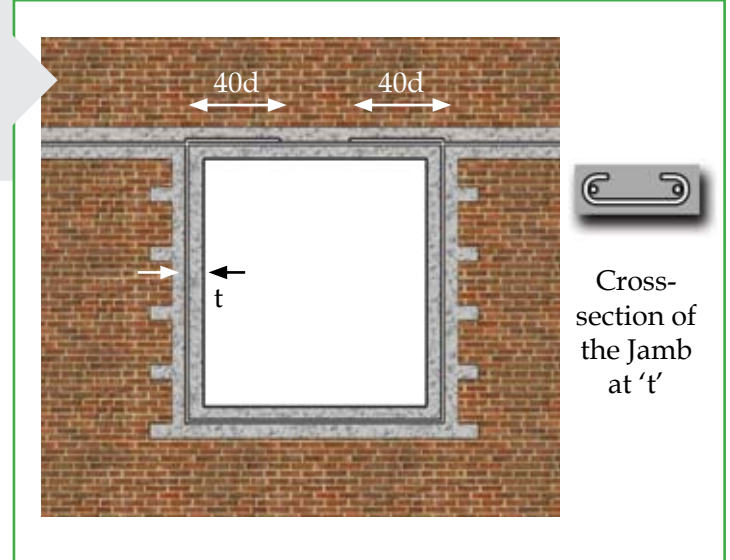

Cross-section of the Jamb at 't'

Reinforcement around openings helps

Design Considerations

- Avoid too many openings in the wall
- The minimum distance between unreinforced openings should be 600mm

1.4 Openings

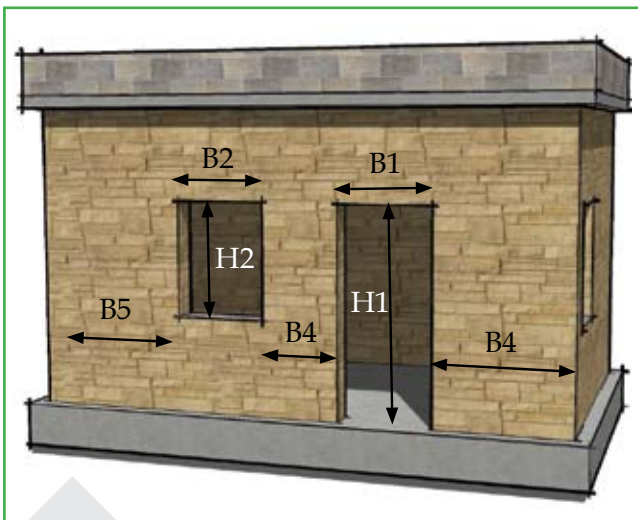
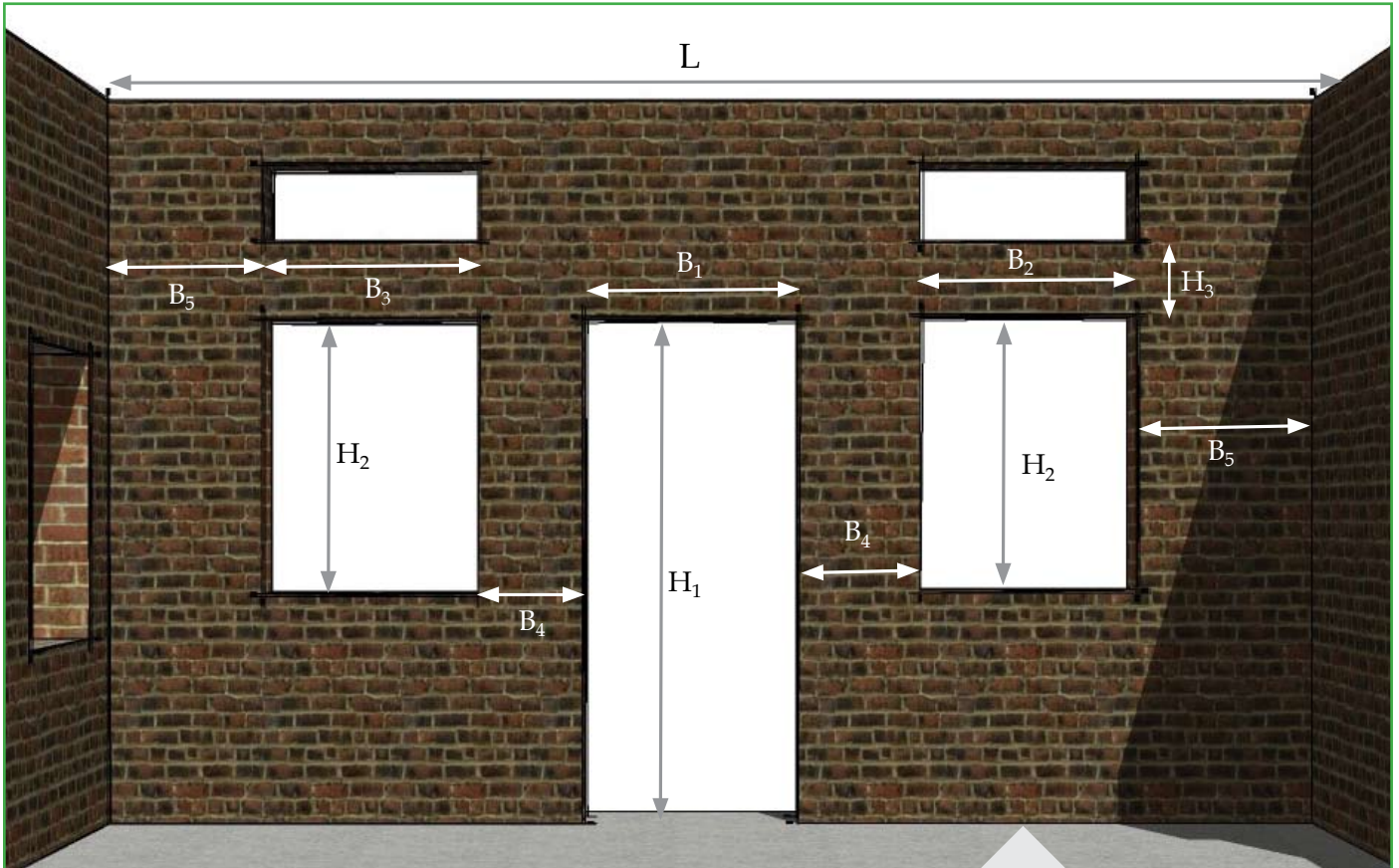

Stone Masonry

$$B_1 + B_2 < 0.3L$$

$$B_4 \geq 0.50H_2 \neq 600\text{mm}$$

$$B_4 \geq 0.25H_1 \neq 600\text{mm}$$

Brick Masonry

$$B_1 + B_2 + B_3 \leq 0.5L \text{ (for One Storey)}$$

$$\leq 0.42L \text{ (for Two Storey)}$$

$$\leq 0.33L \text{ (for Three storey)}$$

- $[600\text{mm} \leq B_4 \leq 0.5H_2]$

Horizontal distance (pier width) between two openings should not be less than 50% the height of the shorter opening (and not less than 600mm)

- $[600\text{mm} \leq B_5 \leq 0.25H_1]$

Openings to be located away from the corners by clear distance equal to at least one fourth of the height of opening or 600mm whichever is more

- $[H_3 \leq 600\text{mm} \text{ or } 0.5(B_2 \text{ or } B_3)]$

Vertical distance from an opening to opening above should not be less than 600mm and half the width of smaller opening

Columns & Beams 1.5

Columns and Beams are main elements of the RCC frame construction. They should be designed for Earthquake resistance and detailed as per the ductile detailing norms. If the ductile detailing is not followed, the structure will be damaged in the event of a dynamic loading during disasters.

Min concrete Grade for RCC should be M20 i.e. 1: 1.5 :3 for volumetric proportioning. Where 3 is a mix of 10mm and 20mm down aggregates in 50/50 or 60/40 ratio.

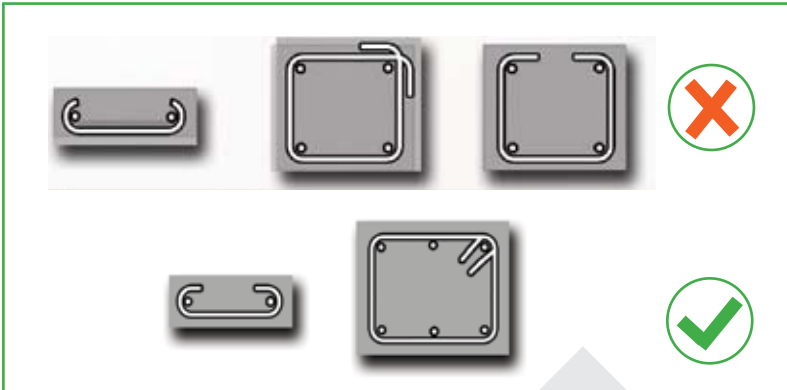

PROVIDE

- Bend the Stirrup through 135°

AVOID

-Inadequate Stirrup Details

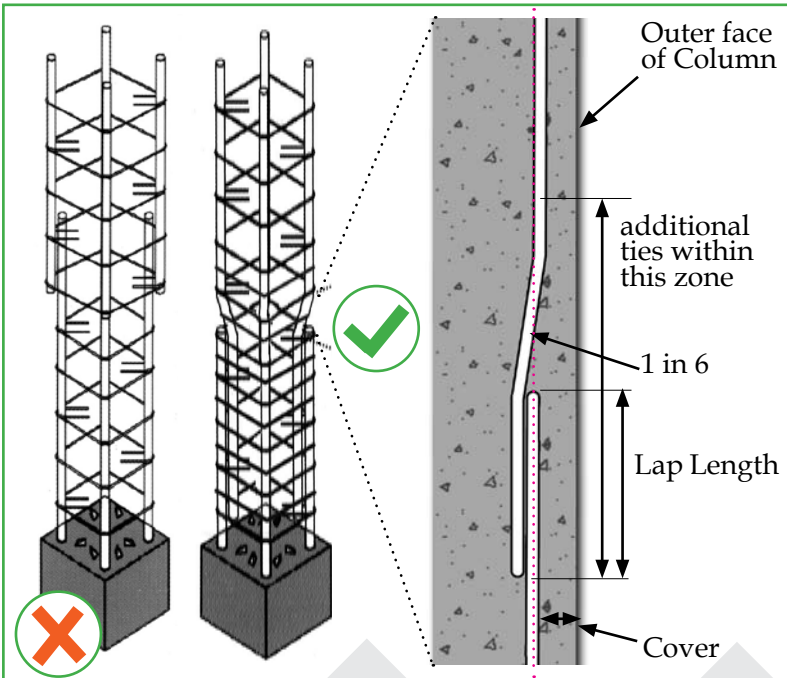

PROVIDE

- Adequate Lap Length with slope of 1:6

AVOID

- Insufficient Lap Length

Splice with Offset Cranked bar in a Column

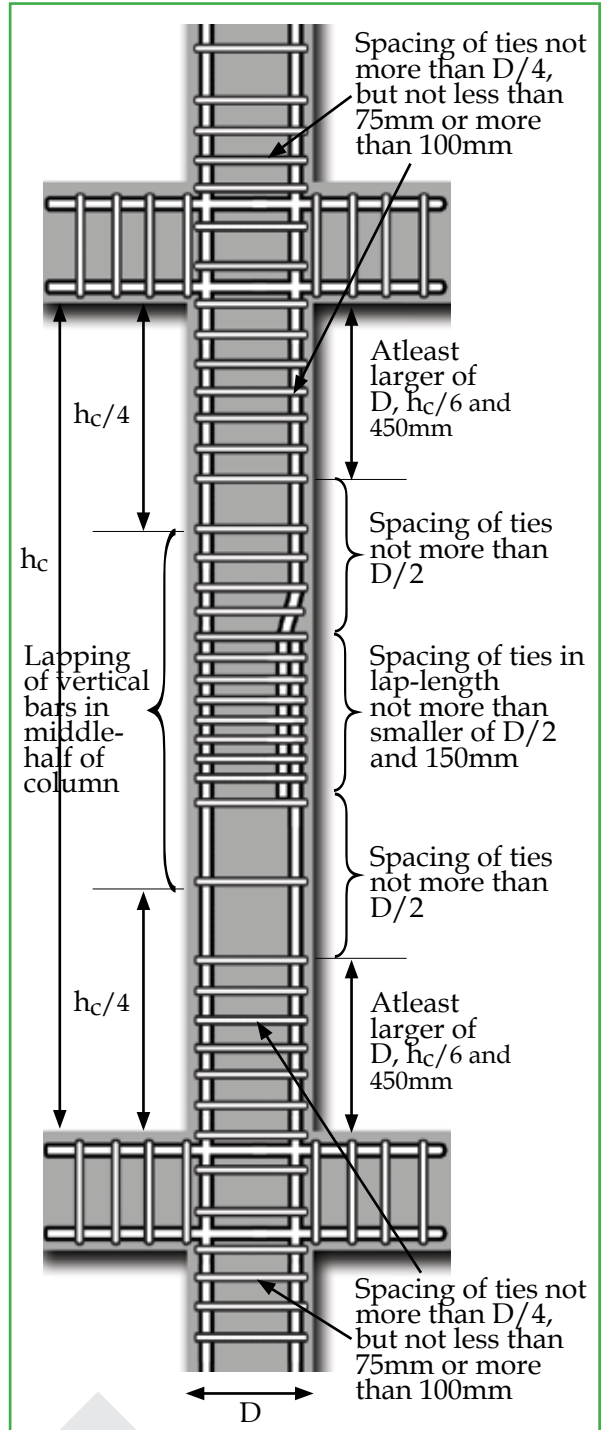

Placing vertical bars and closed ties in Columns

1.6 Column & Beam Junctions

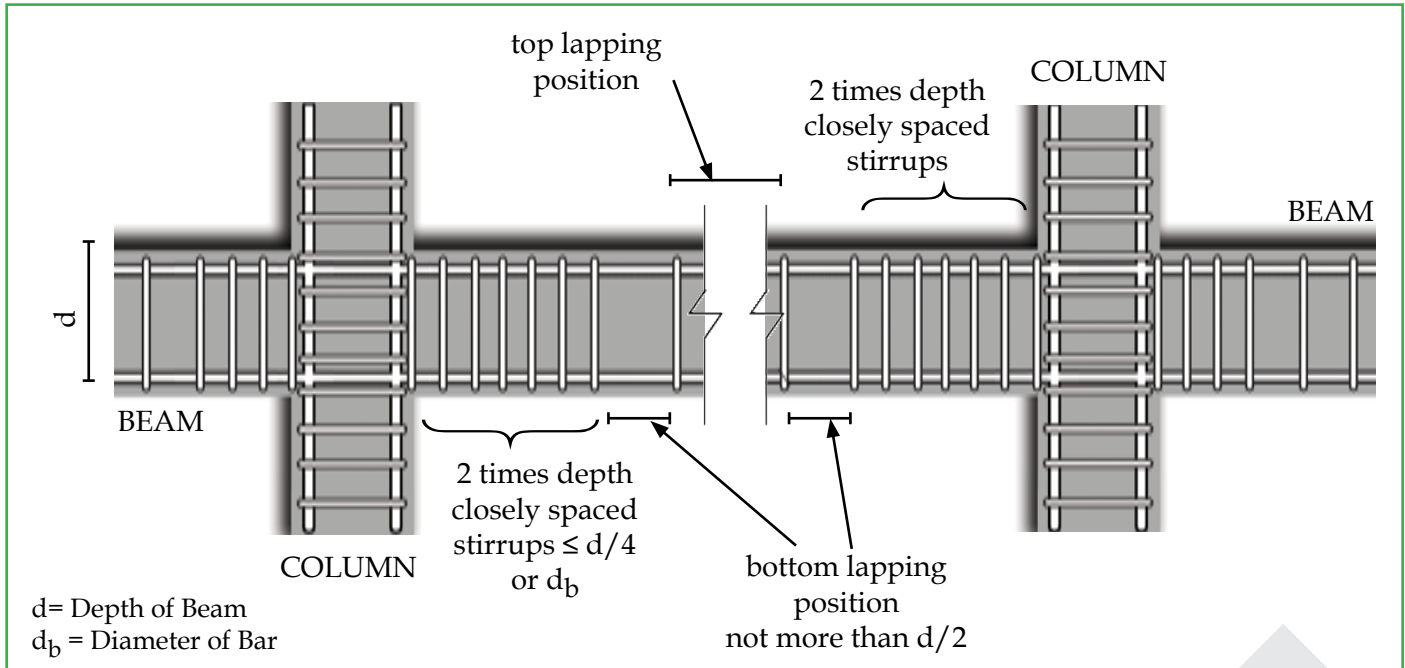

Reinforcement Detail of Beam

Beam bars bent in joint region overstress the core concrete adjoining the bends

Column should have minimum four 12 diameter bars. It is preferable to use TMT bars near the coast line.

A. Reinforcement Detail of Beam-Column Joint at Roof Level

B. Reinforcement Detail of Beam-Column Joint at Floor Level

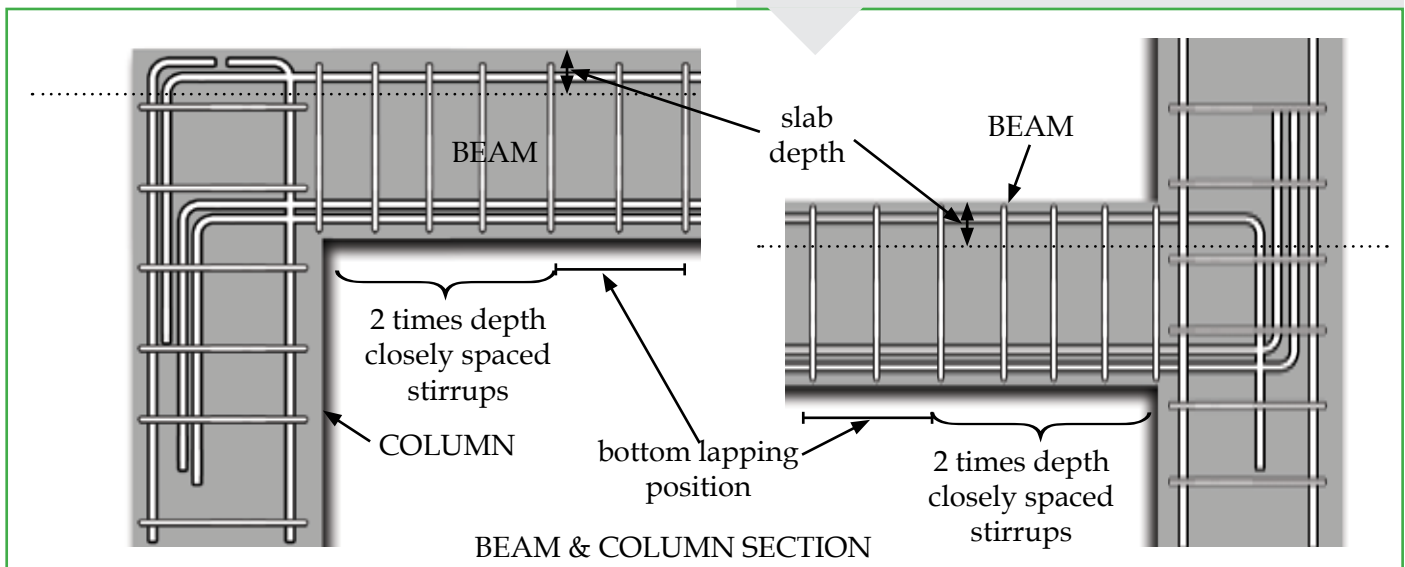
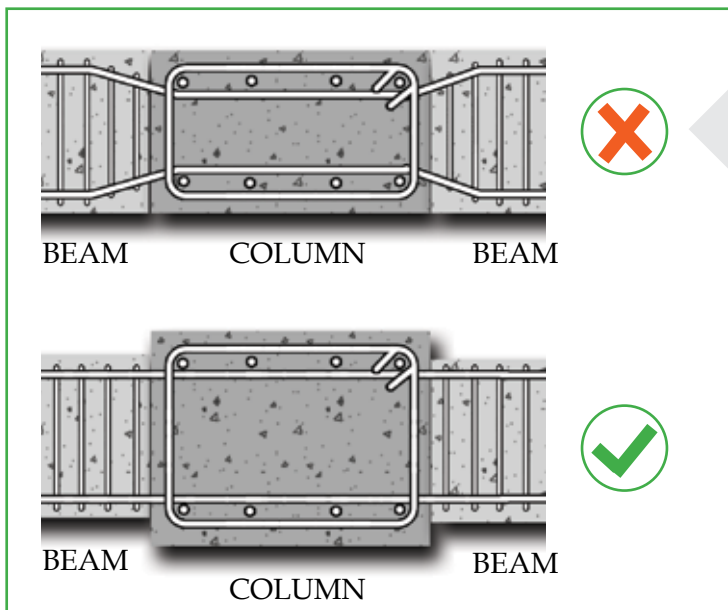

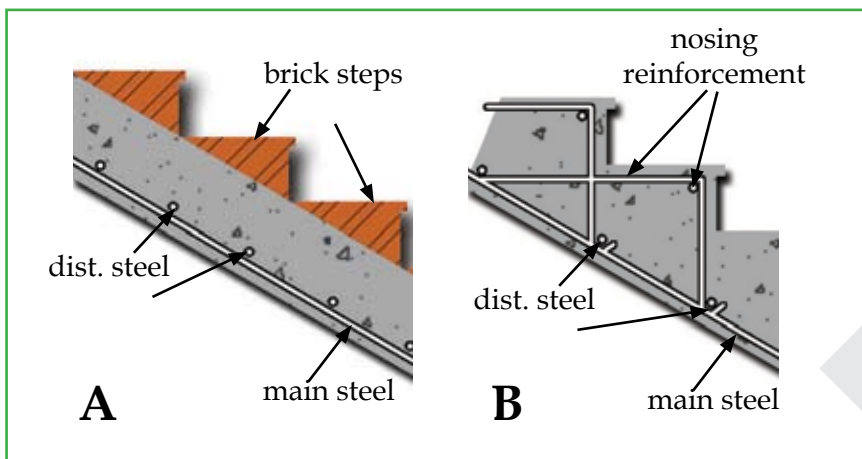
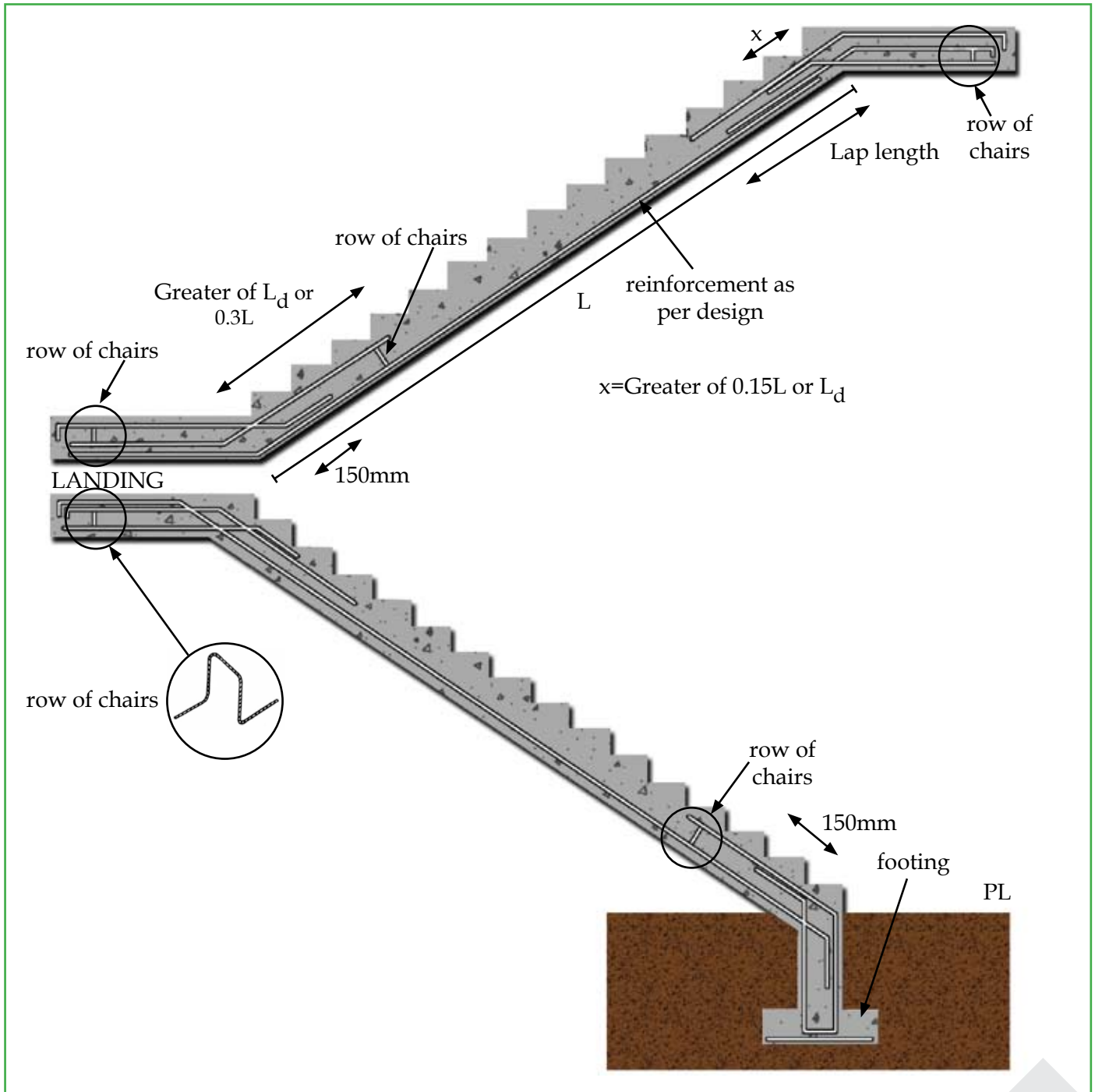

Showing Main Reinforcement OF Stair Supported at Ends of Flights

Steps Details
A. Stair with Brick Steps
B. Stair with RCC Steps

Overhangs and Slabs

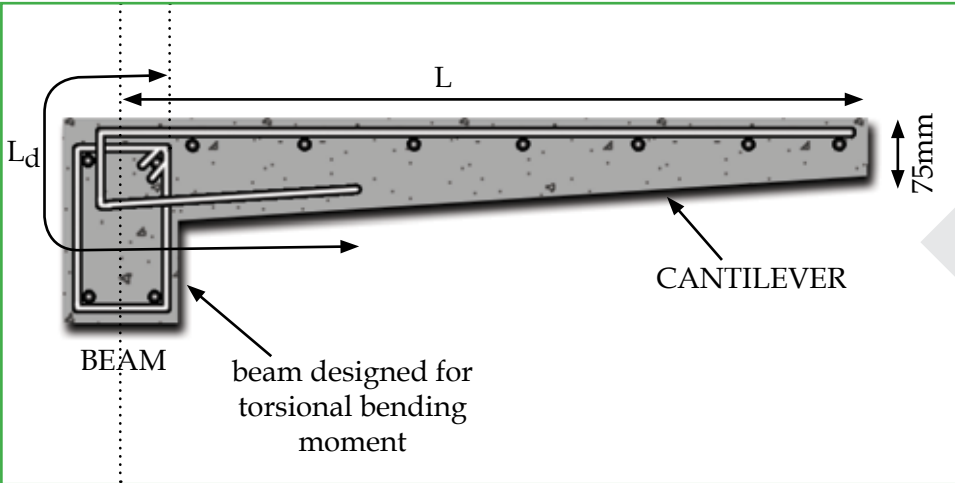

Detail for Sun-shade or any cantilever starting from top-edge of the support of the Beam

A, B :

Alternative Details for sunshed or any cantilever slab starting from bottom edge of the support beam

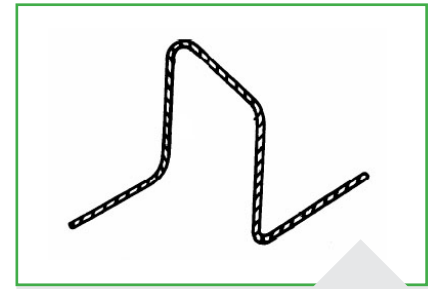
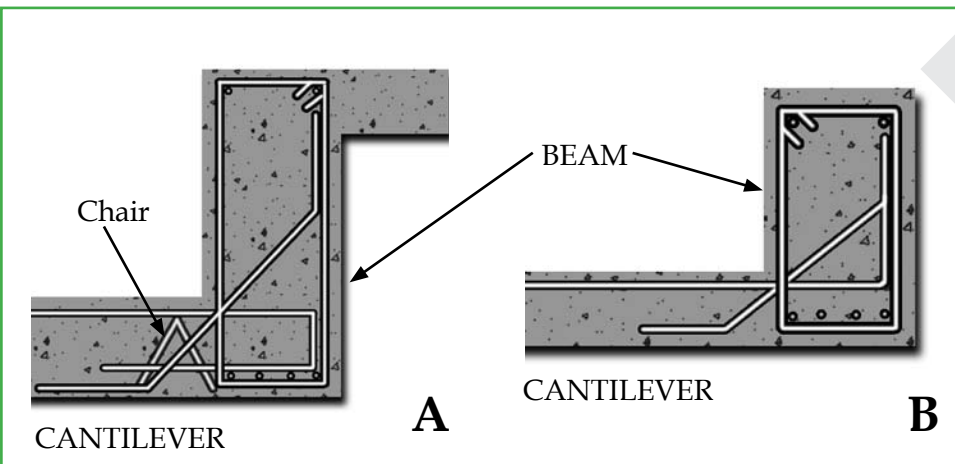

Chair to maintain negative steel in position

Anchor the vertical tie into the roof slab

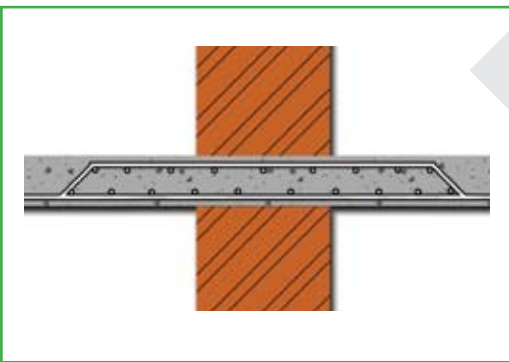

Cast-in-situ
RCC Slab at the support should be reinforced at both top and bottom

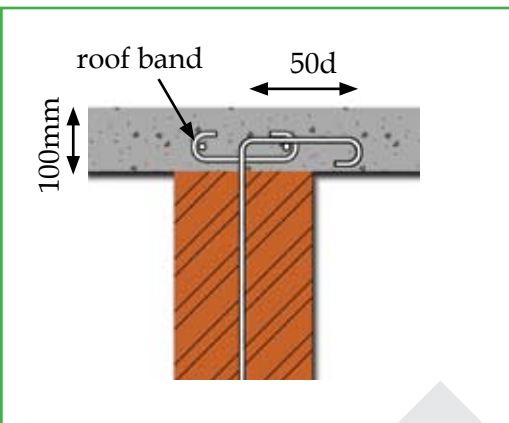
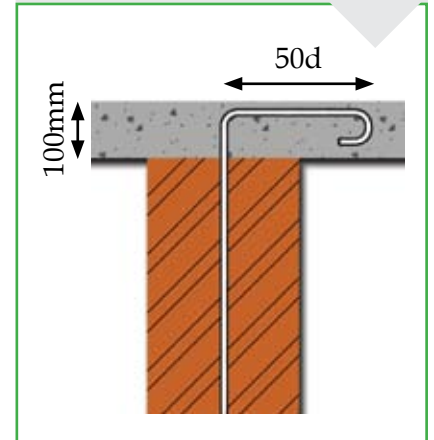

Roof band should be provided within the roof-slab

PROVIDE
Proper weathering course with pressed tile layer to protect RCC Slab.

Slabs 1.9

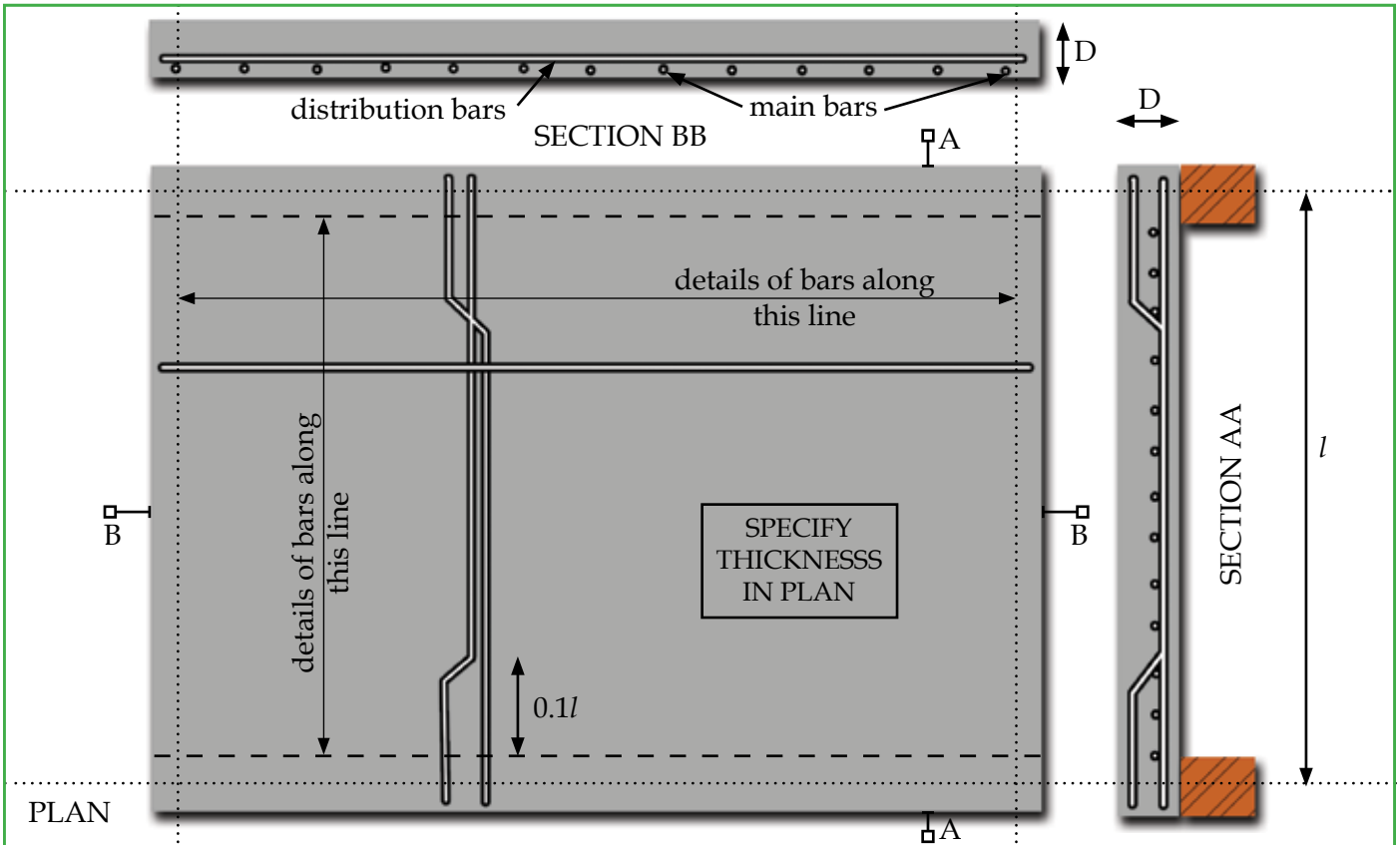

One-way Slab simply supported on Brickwork without torsional steel.

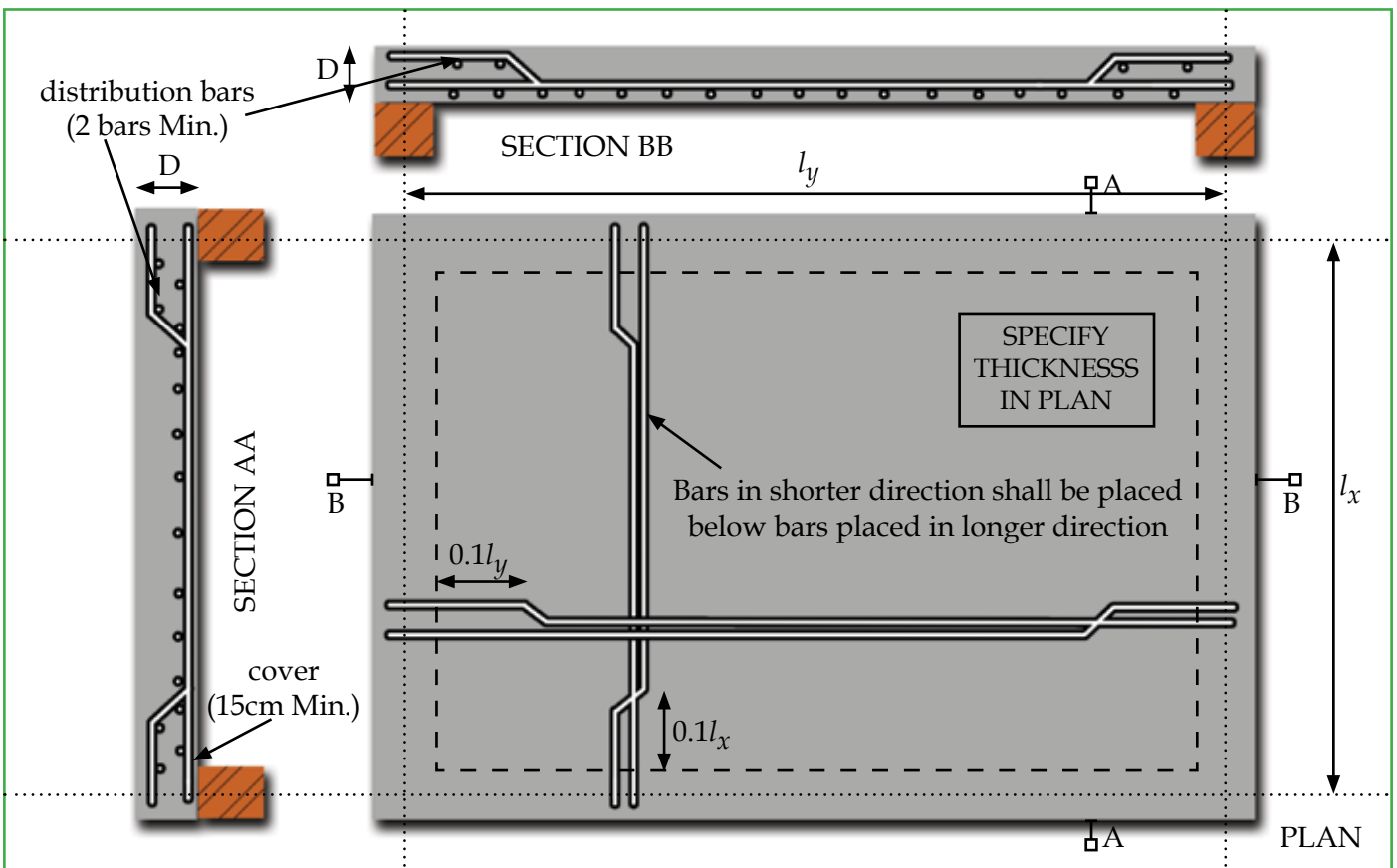

Two-way Slab simply supported on Brickwork without torsional steel.

2.0 Construction Practices

Lineout 2.1

If the basic sketch plan of the building is like A then engineer should prepare a detail line out sketch working out center lines and diagonals as shown in B. The permanent center line marking should be set at this stage to maintain the same as a reference for all agencies.

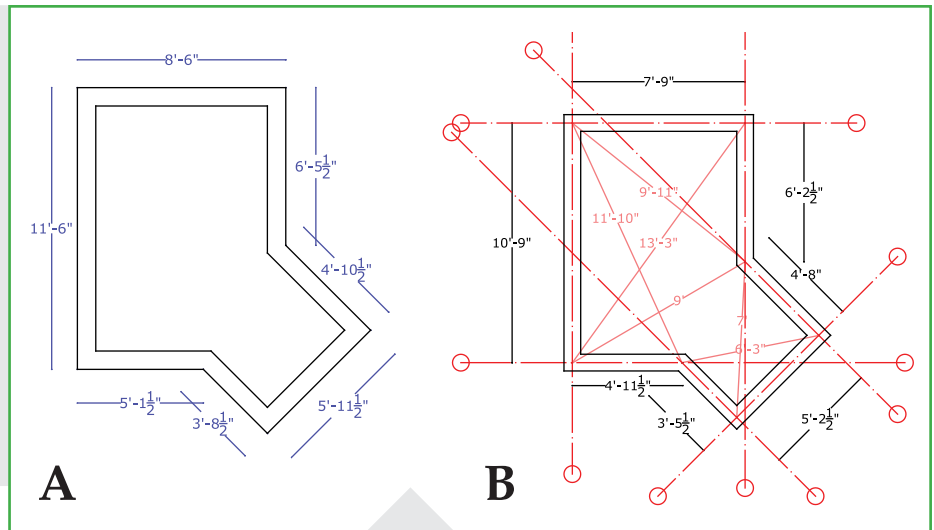

Permanent Benchmarks should be marked for all Center Lines as in B.

Foundation 2.2

Once the line out is done, the Engineer In-charge should give the excavation depth based on the drawing and actual ground condition. The same should be marked on the permanent Bench mark for monitoring.

PCC 2.3

PCC or foundation concrete should be done in 1:4:8 with 40mm down aggregate.

The practice of using stone bat as level is a wrong practice since it follows ground contour and doesn't give a common level

The centerline should be transferred on the PCC before proceeding for the reinforcement erection

The PCC level should be marked on the sides of the excavated pit in such a way that at any location we get minimum pcc depth as specified in the drawing.



Good system of marking alignment on PCC

2.4 Footing

Footing mat should also have minimum cover of 50mm below and should be installed as per the detail given in section 2.1

While erecting column cage care should be taken so as to start the first link correctly as shown in sketch



Starting the first stirrup correctly

2.5 Footing Concrete

Should be done in line and level as specified in the drawing. The slope of footing is very important and that should be concreted as specified.



Good quality of concrete in foundation

2.6 Column Starter

Columns are the key structural members for any structure.

It is very important that

- Concrete is of good Quality
- Columns are properly Aligned.
- Dimensional accuracy is maintained

It is a good practice to start the column by first casting the starter for column.

But it is very important that starter concrete quality should be treated with equal seriousness as of main column concrete in terms of quality, alignment and other standard procedures.



Column Formwork 2.7

It is not correct to use brickwork as formwork. This leads to:

- A) Variation in column cross - section
- B) Bad quality of concrete
- C) Mis-alignment of column from centerline

Dimensional variation due to brick formwork



Column should be secured properly from all direction before concreting to ensure vertical alignment

Before erecting the column formwork, all the columns of the structure should be marked, distance and centerline to be checked and cross checked thoroughly. The column formwork must be leak proof .



Grade Beam 2.8

Grade beam is the one which transfers the entire load of wall on to the column



Reduction in Grade Beam due to bad formwork

Quality of Formwork is most important for Good Quality Concreting

The formwork of Grade Beam should be secured properly with needed side support

A wall plate should be used so as to maintain the top alignment of the formwork as shown in the photo.

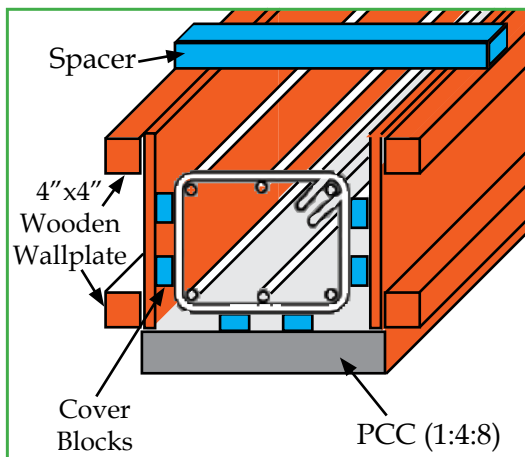

Alignment of the grade Beam should be ensured in line and level

Section of Grade Beam with Formwork

2.9 Concreting

Concrete is on site manufactured material and hence its quality is highly dependent not only on quality of raw material used but also on methodology and compliances in the batching, mixing, placing and curing of concrete.

- M20 in volumetric mix can be achieved by a general proportion of Cement:Sand:Aggregate as 1:1.5:3
- For a good quality concrete 3 share of aggregate is to be divided into 10mm and 20mm down jelly.
- To ensure quality testing concrete cubes and keeping a record is a must.



Good system of batching

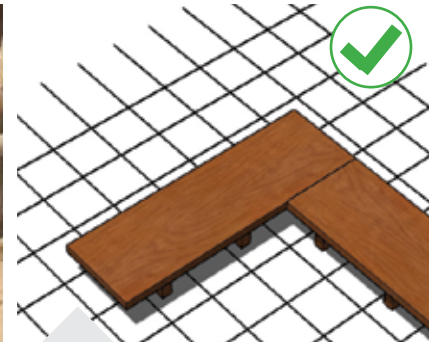

Plank used for walking while concreting

As per IS 456 : 2000 Minimum Grade for any Reinforced concrete construction is M20. Note that 20N/mm. sq. is not the average strength but is the characteristic strength.

Water cement ratio plays a crucial role in the ultimate strength of the concrete. The lower the Water cement ratio, higher the strength.

2.10 Cover Concrete

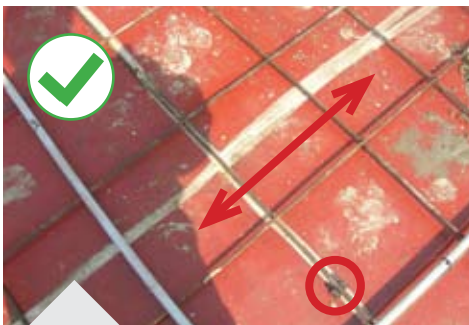

Use of cover blocks and sealant tape in formwork

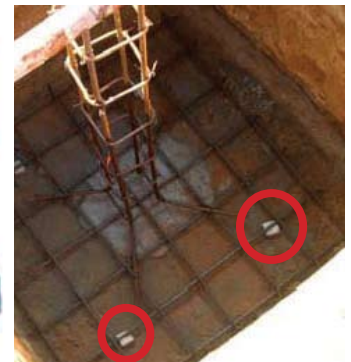

Cover block cast with binding wire to be places on vertical face of members like columns and fastened before concreting.

Cover is one of the most important element of any RCC member. Cover concrete quality is responsible for durability of the concrete and hence ensures the health and long life of RCC members

Nominal cover:

Slab : 15mm, Beam : 20 mm, Column : 40mm and Footing : 50mm. The cover may vary depending upon the exposure condition of structure and also fire safety norms required

Cover Blocks Casting : Cover should be cast in the same grade as the slab concrete since it is ultimately a part of slab concrete. It should be cured and treated as importantly as any other insitu RCC member.

Not ensuring the cover will affect durability of concrete and make it vulnerable to climatic deteriorations. It can also facilitate the twisting of reinforcement while concreting; which hampers structural performance.



AVOID

use inferior Quality of Bricks

Brick

- Colour should be reddish brown and Uniform
- Edges should be sharp, straight and at right angles to faces
- Water absorption should be less than 20% by weight after soaking for 24 Hrs.
- The breakage should not exceed 5% of the lot
- The brick should not break when dropped on their flat face from a height of 60 cms

The Quantity / Quality of Water

- Never add water without measuring
- A marked bucket is the simplest measuring tool
- Never use salty water
- Water should be potable (drinkable)
- pH value should be approximately 7.0



Cement

- The date, month and year of manufacture on the bag reveals the freshness of the cement
- Silky when rubbed between fingers
- When hand is pushed in a cement bag, chillness should be felt. Warmth indicates that hydration has started and cement has aged

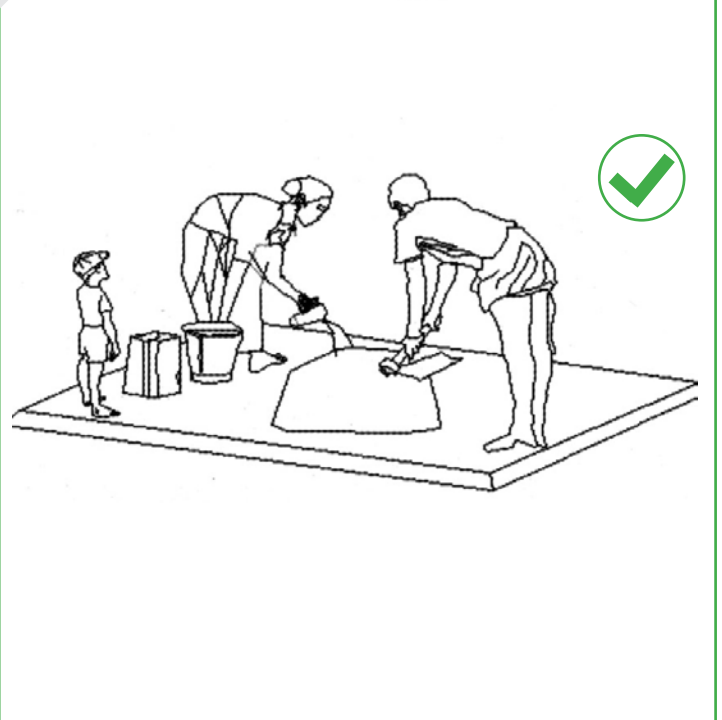

2.12 Storage of materials on site

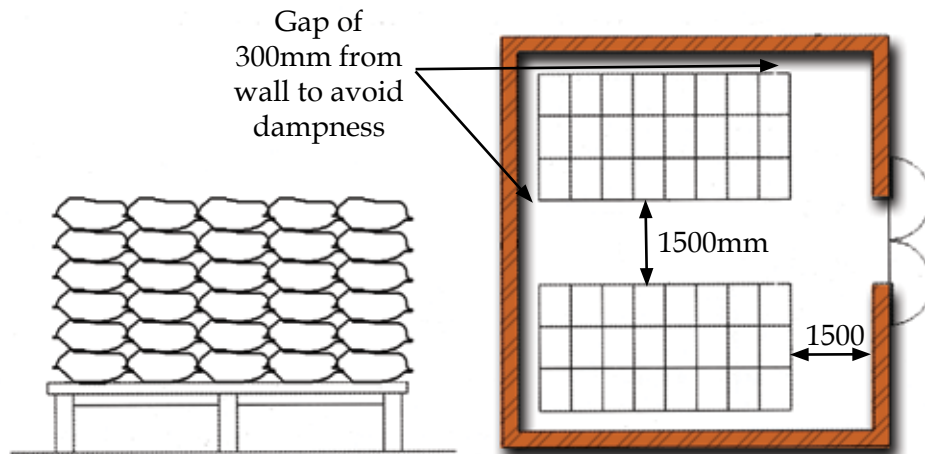

Cement

- Store cement in a Closed room
- Keep the bags 150mm above the floor on a water-proof platform
- A maximum of 6 bags can be kept one above other
- First-in-first-out method should be followed for cement usage
- Avoid dampness by providing water-proof cover

Reinforcement



- Should not be place directly on ground
- Should be placed on a raised platform
- Should be tied and kept neatly
- If stored in open for more than a month, they should be protected by a cement wash
- Before use it should be cleaned to remove mill scales and other impurities

Aggregates

- Stored in a heap having basic dimensions of a Trapezoidal Section, and not haphazardly

4.0 Appendices

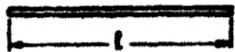
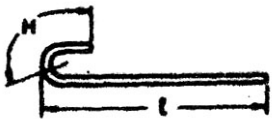
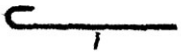
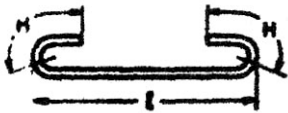
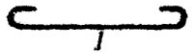
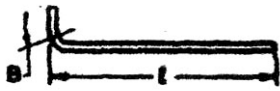
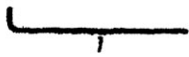
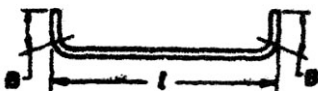
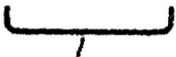
Bar Bending Schedule 4.1

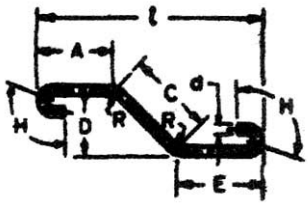
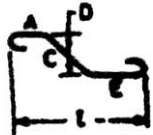
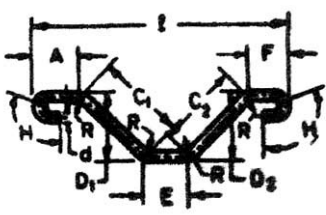
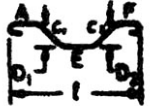
Ref. No.	Method of Measurement of Bending Dimensions	Approx. Total Length of Bar (L) measured along Center Line	Sketch and dimensions to be given in Schedule
A		l	STRAIGHT
B		$l + H$	
C		$l + 2H$	
D		$l + B$	
E		$l + 2B$	
A		Where C is more than $3D$ $A + C + E$	
B		If angle with Horizontal is 45 deg. or less, and R is $12D$ or less $A + C + E + 2H$ or $l + 2H + C - \sqrt{C^2 - D^2}$	
C		If angle with Horizontal is 45 deg. or less, and R is $12D$ or less $A + C_1 + C_2 + E + F + 2H$ or $l + C_1 + C_2 + 2H - \sqrt{C_1^2 - D_1^2} - \sqrt{C_2^2 - D_2^2}$ (If l is specified A, E or F is omitted)	

4.2 Min. Cement Content, Max. Water-Cement Ratio and Min. Concrete Grade for different Exposures

Sr	Exposure	Plain Concrete			Reinforced Concrete		
		Min Cement Content kg/m ²	Maximum free water-cement Ratio	Minimum Grade of Concrete	Min Cement Content kg/m ²	Maximum free water-cement Ratio	Minimum Grade of Concrete
1)	2)	3)	4)	5)	6)	7)	8)
i	Mild	220	0.60	-	300	0.55	M 20
ii	Moderate	240	0.60	M 15	300	0.50	M 25
iii	Severe	250	0.50	M 20	320	0.45	M 30
iv	Very Severe	260	0.45	M 20	340	0.45	M 35
v	Extreme	280	0.40	M 25	360	0.40	M 40

The Coastal environment should be considered as "Severe" exposure condition

4.3 Tolerances

The formwork shall be designed and constructed so as to remain sufficiently rigid during placing and compaction of concrete, and shall be such as to prevent loss of slurry from the concrete. Permissible Tolerances as per IS:456 shall be:

a)	Deviation from specified dimensions of cross-section of Columns and Beams	+12mm -6mm
b)	Deviations from dimensions of footings	
	1) Dimensions in Plan	+50mm -12mm
	2) Eccentricity	0.02 times width of the footing in the direction of deviation but not more than 50mm
	3) Thickness	0.05 times the specified thickness
c)	Reinforcement	
	1) For effective Depth 200mm or less	±10mm
	b) For effective Depth more than 200mm	±15mm
d)	Cover	
	Required nominal cover	+10mm - 0mm



Flyash Brick Masonry
Florida Construction-UNDP



Compressed Stabilized Earth Block
Auroville Earth Institute and UNDP



Rat - Trap Masonry
COSTFORD and UNDP



**Retrofitting technology
demonstration unit**
by SEP and UNDP



Hands on Mason Training

This Handbook has been prepared for the benefit of technical supervisors and masons as a part of Information Education and Communication Campaign in the post Tsunami shelter reconstruction. This is a joint initiative of Government of Tamil Nadu and UNDP. This handbook is prepared with technical assistance from Society for Environment Protection (SEP) and Orissa Development Technocrat Forum (ODTF) under the guidance of Prof. A. R. Santhakumar.

Contact :

Er. Alok Patnaik, Project Officer, Shelter and Habitat, UNDP E-mail : alok.patnaik@undp.org

UNDP, United Nations team for Tsunami Recovery Support,
Apex Towers, 54, 2nd Main Road, RA Puram, Chennai – 600 028
Tel : +91 4442 303 551
Website : www.un.org.in/untrs

**Office of the Special Commissioner and
Commissioner for Revenue Administration,**
Disaster Management & Mitigation Department, Chepauk, Chennai 600 005;
Email : relief@tn.nic.in; Website : www.tn.gov.in/tsunami