

Early Recovery Shelter Cluster Guidelines

ONE ROOM SHELTER

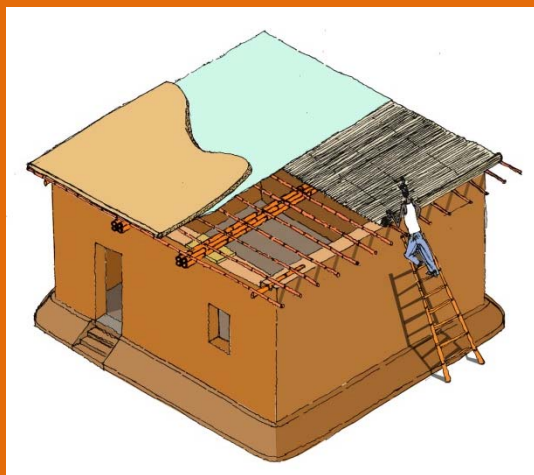

MUD

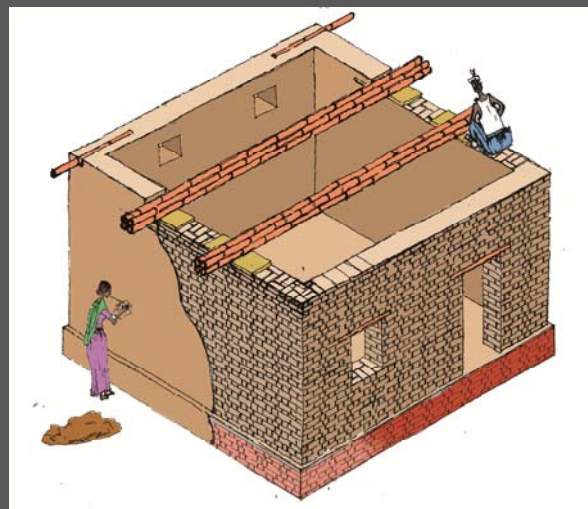

ADOBE



FIRED BRICK

Mud Adobe fired Brick MAB Technical Guideline

ONE ROOM SHELTER

One Room Shelter is a flexible, beneficiary-driven process, which leads to the final product of a safer shelter through the active participation of the beneficiaries. This a type of shelter that adopt familiar vernacular construction practices improved with DRR measures, to ensure the construction of safer shelter and its maintenance. The ORS is a process that promotes the transferring of knowledge on safer construction techniques to vulnerable groups, as a way to improve communities' resilience to disasters. It may be considered as the first step towards reconstruction, afterwards beneficiaries can upgrade it according to their needs and the improvement of their capacities and resources.

DIMENSIONS

The dimension of ORS may be different depending on the needs of the family, the technique adopted and the financial resources. The minimum standard for a family of 6/7 persons is a surface of 16/20 mq, i.e. 170/260 square feet. Thus the dimension may be from 14'x14' up to 16'x16'. The internal height should be never less the 10' from the floor level. The plinth has to be raised at least 1'6" above the Natural Surface Level (NSL).

ONE ROOM SHELTER

Mud Adobe fired Brick MAB Technical Guideline

INDEX OF THE CONTECTS

MUD

Phase 1: excavation

- Excavation

Phase 2: foundation

- Bearing foundation
- Foundations
- Reinforcement of foundations

Phase 3: raised plinth

- Plinth
- DPC
- Reinforcement

Phase 4: elevation

- Execution by ramming layers
- Reinforcement
- DRR: Reinforcement at corners
- DRR: Buttresses
- Sill level
- DRR: waterproofing
- Lintel level
- Openings
- Lintels and options
- Roof level
- Bearing pad and roof band
- Ventilation

Phase 5: roof

- Main structure
- Secondary structure
- Options
- Roofing cover
- DRR measures

Maintenance

ADOBE

Phase 1: excavation

- Excavation

Phase 2: foundation

- Bearing foundation
- Foundations

Phase 3: raised plinth

- Plinth
- DPC
- DRR: reinforcements

Phase 4: elevation

- Sill level
- DRR: reinforcement
- DRR: waterproofing
- Lintel level
- Openings
- Lintels and options
- Roof level
- Ventilation
- Bearing pad and roof band

Phase 5: roof

- Main structure
- Options
- Roofing cover
- DRR measures

Maintenance

FIRED BRICK

Phase 1: excavation

- Excavation

Phase 2: foundation

- Bearing foundation
- Foundations

Phase 3: raised plinth

- Plinth
- DPC
- DRR: reinforcements

Phase 4: elevation

- Sill level
- DRR: waterproofing
- Lintel level
- Openings
- Lintels and options
- DRR: reinforcing bands
- Roof level
- Ventilation
- Bearing pad and roof band

Phase 5: roof

- Main structure
- Options
- Roofing cover
- DRR measures

Maintenance

ONE ROOM SHELTER

Mud Adobe fired Brick MAB Technical Guideline

ACRONYMS

SC	Shelter Cluster
TWIG	Technical Working Information Group
ERS	Early Recovery Strategy
TGL	Technical Guidelines
ORS	One Room Shelter
TS	Temporary shelter
MAB	Mud Adobe fired Brick shelter
NSL	Natural Surface Level
FL	Floor Level
SL	Sill level
LL	Lintel Level
RL	Roof Level
DPC	Damp Protection Course
DRR	Disaster Risk Reduction
RCC	Reinforced Compacted Concrete

ONE ROOM SHELTER MUD

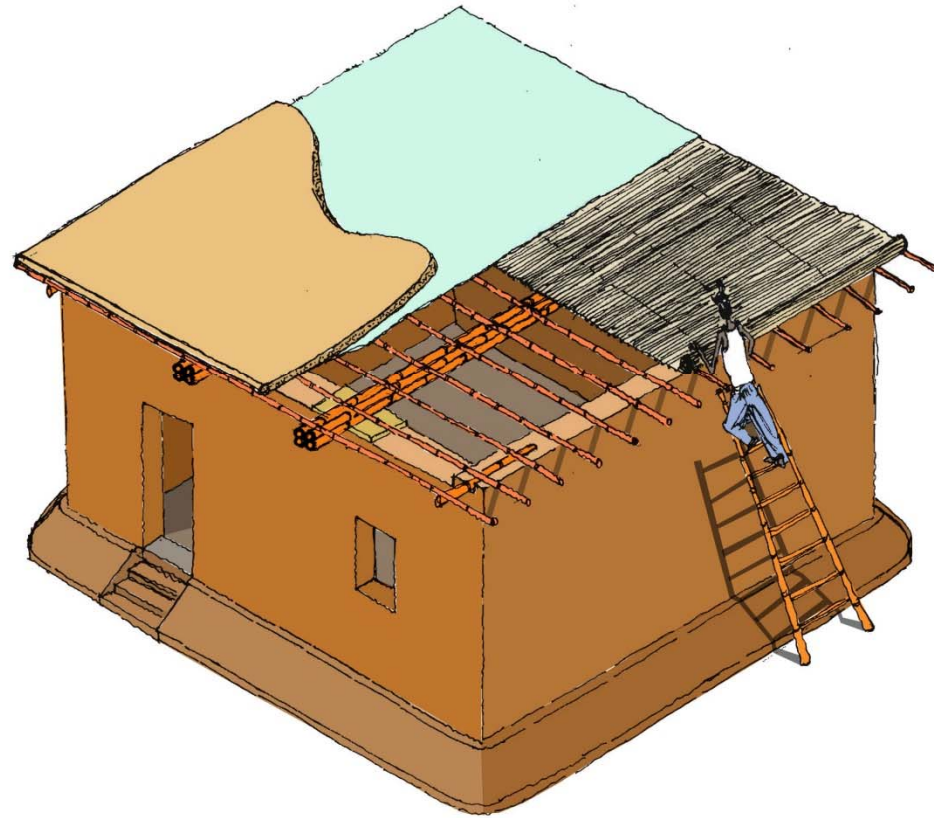

MUD VERNACOLAR SHELTER

Mud shelter is completely built up with mud, which has been kept soaked in the water for at least 24 hours. The foundations may be built with stones and the raised plinth protected with a mud toe. The foundations may be in fired brick masonry and cement sand mortar as DRR. The superstructures has to be raised up by ramming layers of 12" height per day, each cured before executing the next. The thickness of the walls has to be 18" minimum at the base and never less than 13" at the top.

DRR measure against floods is plastering at least until the sill level the walls, external and internal, with stabilized mud or a mixture of mud bitumen and kerosene. The whole plastering till the roof level ensures a better protection against to rainflash too. The same DRR has to be applied above the roof, ensuring continuity of the plaster between the roof and the walls. The eaves may protect the walls from the eroding action of the rain.

DRR against earthquake may be a reinforcement with a vertical frame, at the corners and reinforced bands at floor, sill, lintel and roof level. The roof band is always suggested.

MUD SHELTER

PHASE 1 and 2	EXCAVATION, BEARING FOUNDATIONS AND FOUNDATIONS
<i>Generic Guidance</i>	<ul style="list-style-type: none"> - The excavation depth minimum 18" below undisturbed ground or compacted soil - The bearing foundations (under-foundations) should be in stones - The wall structure needs to penetrate to a minimum of 18" in the ground reaching the solid layer and being reinforced with cement or lime mud posts, to ensure stability to the shelter - The minimum dimensions for the foundations are 2.5' wide footings founded 2' below the Natural Surface Level (NSL)
<i>Specific Guidance</i>	<ul style="list-style-type: none"> - Wall columns (skeleton) may improve the wall structure, they have to penetrate the ground at least 18" to reach the solid layer and be reinforced with cement or lime mud posts, to ensure the stability of the shelter
<i>Notes and recommendations</i>	<ul style="list-style-type: none"> - A tapered foundations (continuous plinth) better distribute the loads to the ground. They may be obtained by ramming well compacted frameworks - The foundations may be in stones, fired bricks, concrete; cement-sand mortar is preferred - Tapering or ramming mud frameworks may be improved by adding cement and lime, this provides waterproofing resistance - Wall columns in wooden poles (skeleton) or bricks may reinforce the structure (DRR against earthquake) - The poles of the skeleton have to be anchored appropriately to the foundations

MUD SHELTER

Phase 1: excavation

Excavation depth should be minimum 18" under undisturbed ground

18"

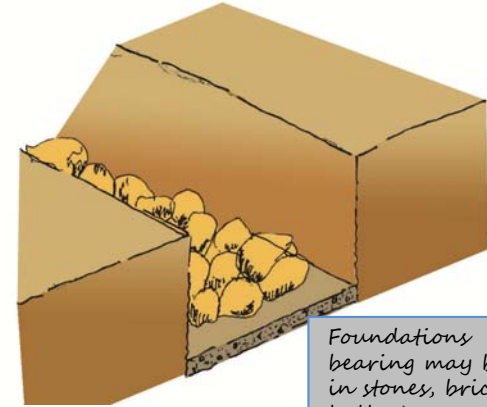
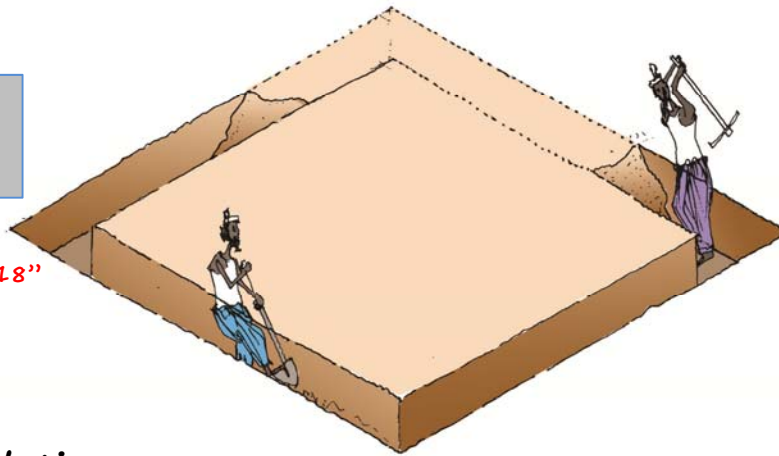

Foundations bearing may be in stones, brick ballast, concrete.

Phase 2: foundation

- Bearing foundations
- Foundations
- Reinforcement

Tapered foundation better distributes the loads.

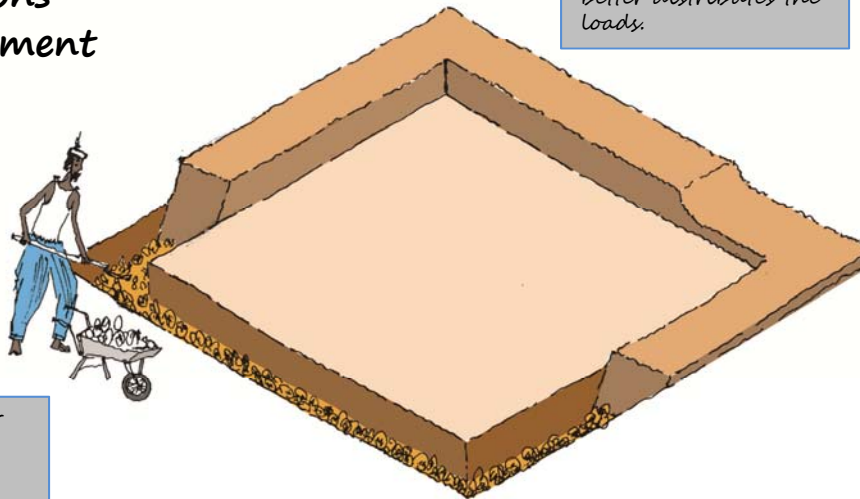

Adding lime or cement gives waterproofing resistance

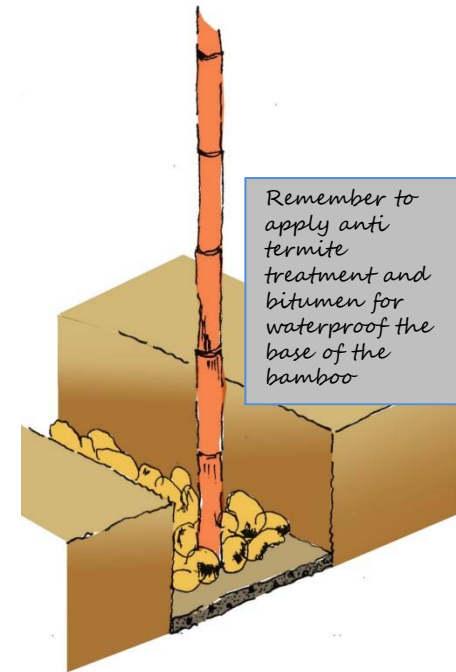

Remember to apply anti termite treatment and bitumen for waterproof the base of the bamboo

MUD SHELTER

PHASE 3	RAISED PLINTH FLOOR
<i>Generic Guidance</i>	<ul style="list-style-type: none"> -The floor level should be raised with a continuous plinth, at least 1'6" up to 3' above the Natural Surface Level (NSL) -General recommendation is to protect the foundations below floor level by raising an earth platform 3' wide at the top and tapering to NSL over 6'. (i.e. 1 in 2 slope minimum.) The top of this platform should be 6" below floor level -A damp proof course (DPC) at plinth level is compulsory in order to prevent moisture rising into the walls. A DPC is either a thin layer of concrete at plinth level with plastic on one surface or simply a strong plastic layer
<i>DRR improvements (Flood and earthquake)</i>	<ul style="list-style-type: none"> -Tapered or rammed mud frameworks may be improved by adding cement and lime for providing waterproofing characteristics -The plinth may be in stones, fired bricks, concrete; cement/sand mortar has to be used -At the top of the plinth an horizontal reinforcement may be executed; it can be with bamboos or timber, well connected with the vertical poles; they have to be overlapped and tied at the corners
<i>Maintenance</i>	<ul style="list-style-type: none"> -Re-plaster with lime/mud/cement mortar the raised plinth at least once yearly, before the monsoon season, and whenever necessary

MUD SHELTER

Phase 3: raised plinth

- Plinth
- DPC
- DRR measures

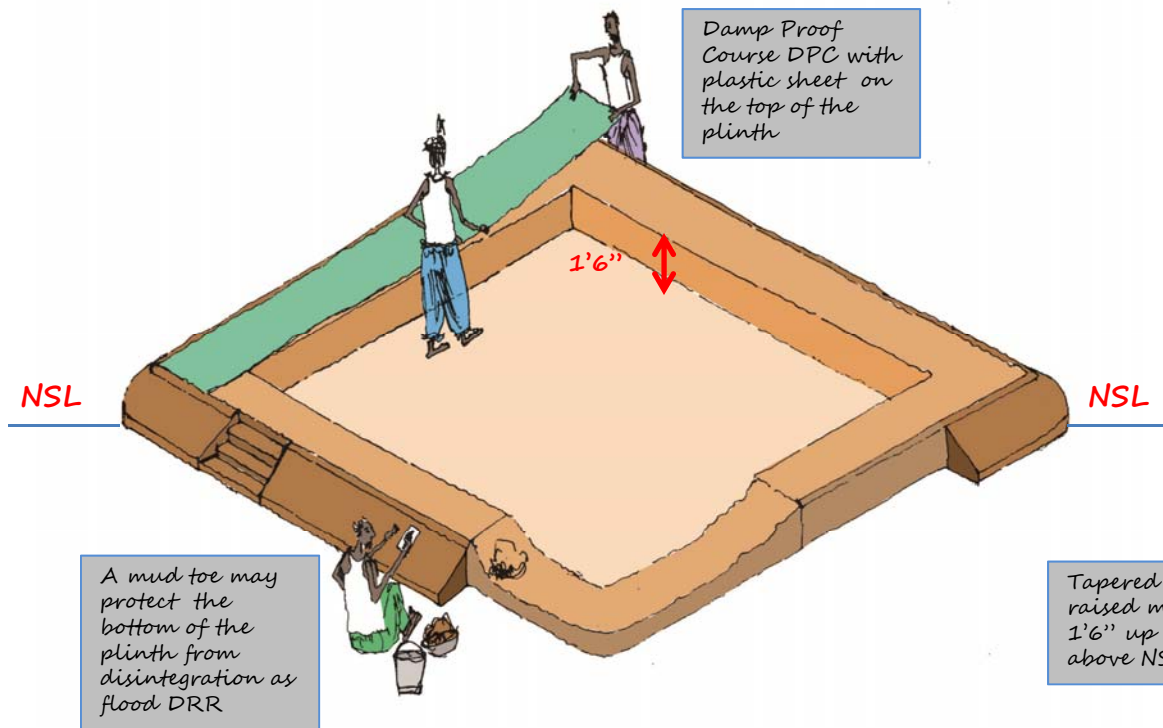

Damp Proof Course DPC with plastic sheet on the top of the plinth

A mud toe may protect the bottom of the plinth from disintegration as flood DRR

Reinforcement with horizontal band as seismic DRR. Ensure appropriate anchoring with the vertical frame

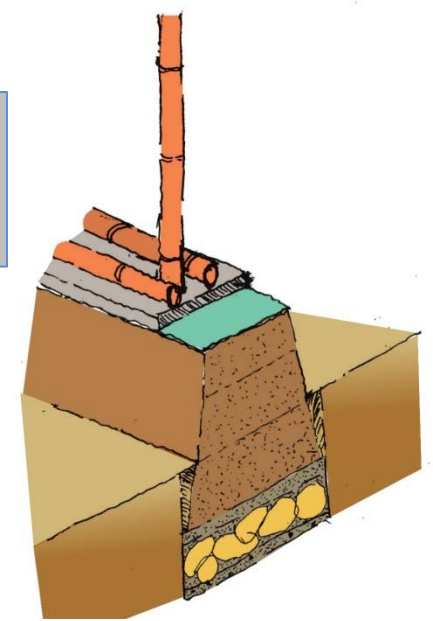

DPC with plastic sheet and concrete cover layer

Tapered plinth raised minimum 1'6" up to 3' above NSL

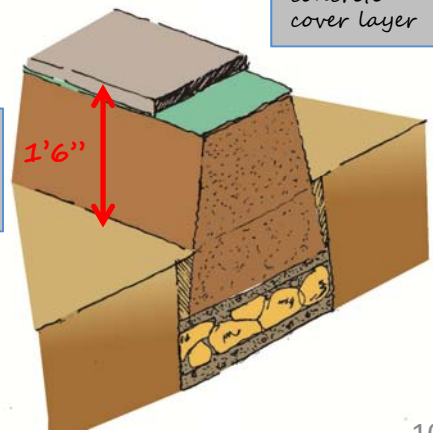

MUD SHELTER

PHASE 4	SUPERSTRUCTURE
<p>Walls Core materials and techniques</p>	<ul style="list-style-type: none"> -Unreinforced mud walls, i.e. a mixture of mud and straw or any other materials, should be minimum 18" thick at the base (2'-2.5' preferred). The walls should not taper to less than 13" at the top. (1.5' is preferred) -The thickness will provide resilience and distribution of loads from roof to ground -The resistance and the durability of the wall depend on the compaction. The compaction can be improved by ramming the walls -Unreinforced mud walls should be built up in layers of 12" maximum height per day. The layers have to be cured or hardened prior to application of subsequent layers. Time of fermentation of mud will vary according to the weather conditions at the time of construction. An estimate of 3 to 4 days per layer is suggested. Local knowledge should be sought regarding appropriate length of time for curing -The right width plinth and the plumb of the walls themselves ensure the stability
<p>Notes and recommendations</p>	<ul style="list-style-type: none"> - The mud used for the walls has to be carefully selected - Sand, lime and cement may be added in different proportions
<p>DRR for earthquake resistance Joint and binding Reinforced bands</p>	<ul style="list-style-type: none"> -The mud walls are heavy and will perform badly in earthquake -Mud walls longer than 14' should have intermediate cross partition wall -DRR for earthquake resistance may be improved by vertical and horizontal reinforcements -Vertical elements as bamboos or timber provide confinement to the walls and directly support the roof -The horizontal reinforcements avoid the separation of the wall, they may be done with steel, wire mesh, timber, bamboo and seven juta rolls -The band at roof level should be always executed -Also stitches as cut timber or cane may be inserted in each corner and junction. they should extend 3' from each side and vertically provided at every 2' -Buttresses may support the stability of long wall and corner. Buttresses can be full or partial height, straight or inclined

MUD SHELTER

Phase 4: elevation

- Execution by ramming layers

Ramming the walls improves the compaction, increasing the durability

The layers have to be cured or hardened prior the application of the subsequent one. Time of curing depends on the weather conditions

Reinforced walls with bamboo skeleton

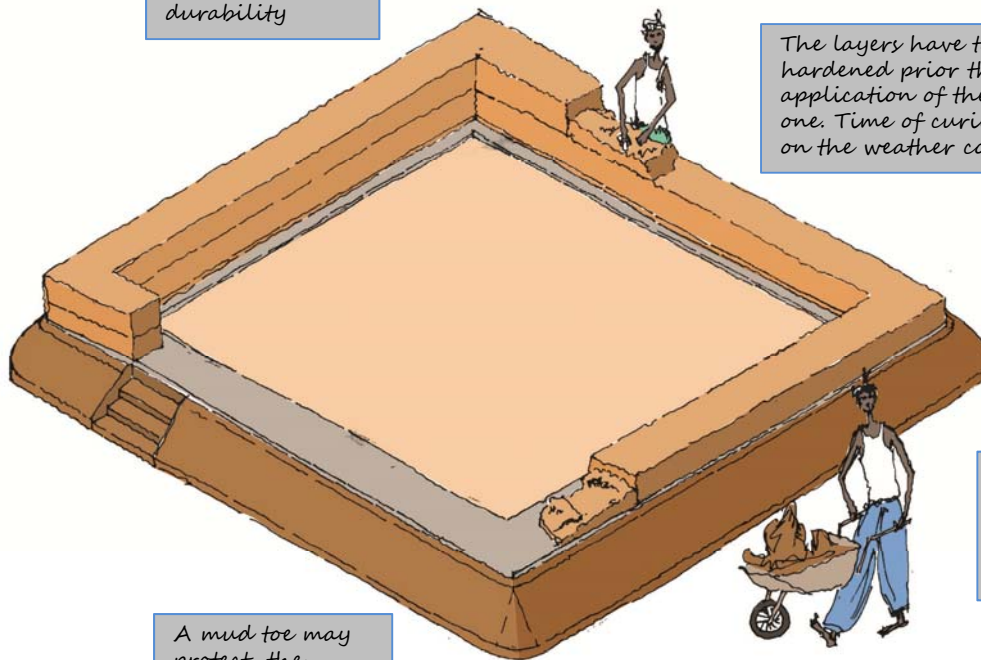
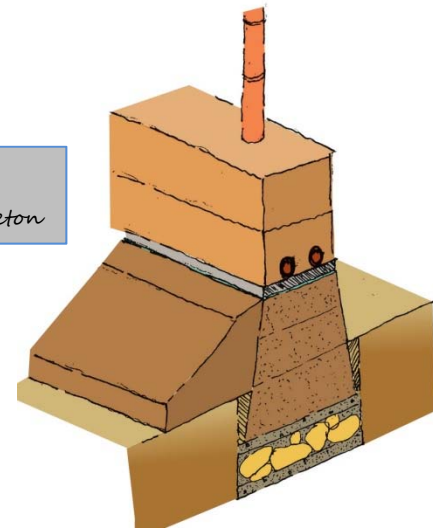

Unreinforced walls should be minimum 18" thick at the base and never less than 13" at the top

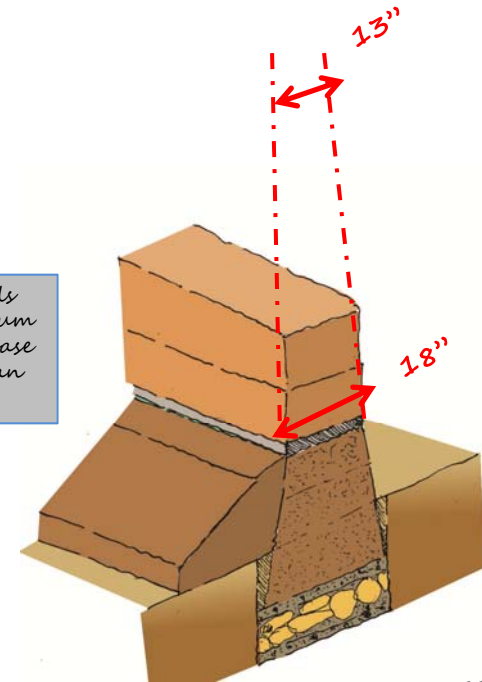

A mud toe may protect the bottom of the plinth from disintegration, as flood DRR

MUD SHELTER

Phase 4: elevation

- Reinforcement at corners

Horizontal reinforcements avoid the separation of the walls at the corners

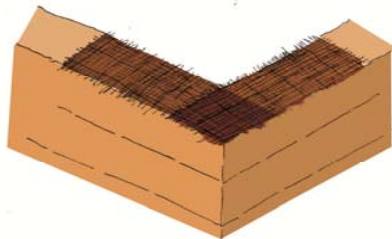

Horizontal reinforcements may be done overlapping jute rolls. They should be applied every 2 mud layers and extended of 2'

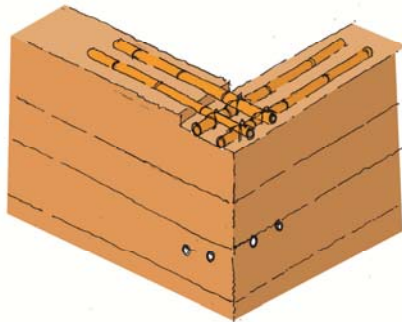

Bamboos or timbers are an option. They should be inserted every 2-3 mud layers, overlapped at the corner and prolonged of 2''



Wire mesh is also an option, if protected by a cement casting

Buttresses may support the stability of the corners

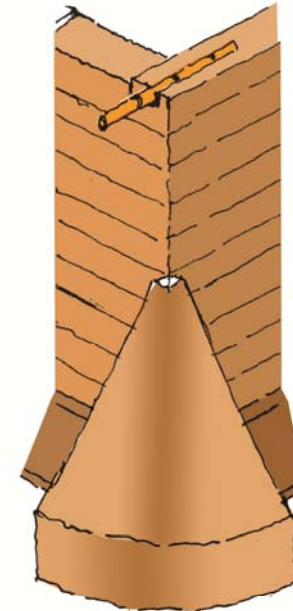
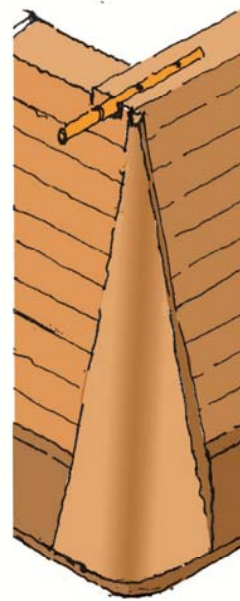

Buttress may have the same height of the walls, with a base wide almost like the toe at bottom

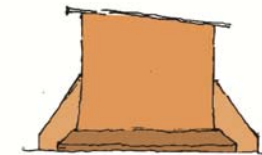

Buttress may have the half height of the walls, with a base larger than the toe at bottom

MUD SHELTER

PHASE 4	SUPERSTRUCTURE
<i>DRR flood resistance (plaster as protective and expendable surface)</i>	<ul style="list-style-type: none">-A lime-mud mix (1:3 mixture) for plaster may provide some waterproof resistance to the inner structure-Also bitumen stabilized mud mortar is an effective treatment, it makes waterproofing and fire resistant the walls. It should be prepared by mixing bitumen with kerosene oil (5:1) and mud (1.5 kg of bitumen for 30 kg of mud) shoveled thoroughly-The walls have to be plastered till the roof level with 2/3 coats-A mud toe may further protect the bottom of the walls from disintegration
<i>Maintenance</i>	<ul style="list-style-type: none">-Re-plaster with lime/mud/cement mortar the walls at least yearly or whenever necessary (worn-out plaster)-Re-apply the film of bitumen yearly before the monsoon season

MUD SHELTER

Phase 4: elevation

- Sill level
- DRR measures

The layers have to be cured or hardened prior the application of the subsequent one

The walls have to be plastered till the roof level with 2 or 3 coats of plaster

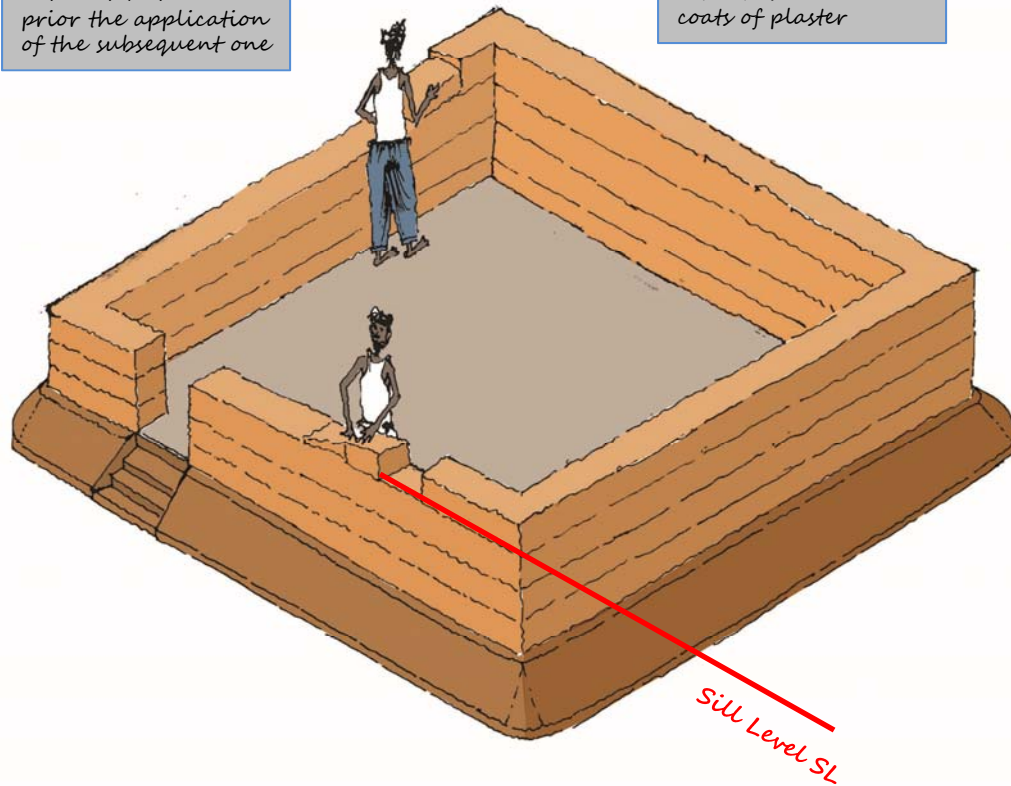

Waterproof measures may be provided by applying a lime-mud mix (1:3) plaster at least till the sill level. The coats should be 3



Bitumen mixed with kerosene (5:1) and stabilized mud (30kg for 1.5 kg/l bitumen) plaster may be an option

MUD SHELTER

PHASE 4	SUPERSTRUCTURE
<i>Opening door window</i>	<ul style="list-style-type: none"> -Openings within the wall space should not take up an area greater than 50% of the wall -Openings should be higher than wider -Windows and doors should be kept a minimum of 2 ft from the corners and from each other -The doors should open outwards for fire safety purpose
<i>Lintels</i>	<ul style="list-style-type: none"> -Lintels have the function to bear and distribute the load of the wall above the openings -Lintels should be designed based on the load being carried overhead -Lintels should be minimum 2" thick and 6" longer than the opening for each side -For short spans timber plate or tied bamboos (2-3) may be an option, which sounds more appropriate to the mud structure -The lintel may be executed with bricks system using n.2 steels #3 and cement mortar -The pre-cast concrete lintel may be a good option
<i>Ventilation</i>	<ul style="list-style-type: none"> -Ventilation is very important mainly during the summer, that is very hot in several areas -Two windows may ensure ventilation. Alternatively one or two ventilators, executed on the opposite side of the window (generally on the back wall) may ensure a good ventilation -The dimensions depend on the size of the shelter, it may be one of 2' x 1' or two 1'x1' -In some areas, where the summer is very hot, it may be suggested to increase the height of the shelter to improve the internal ventilation (in this case the entire structure of the shelter has to be re-calculated)

MUD SHELTER

Phase 4: elevation

- Lintel level
- Opening
- Lintel options

Lintels should be designed accordingly the loads carried overhead

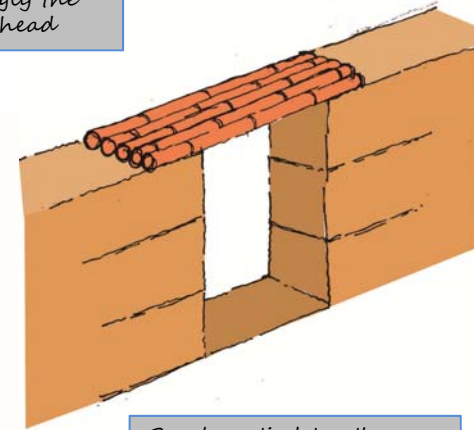

Bamboos tied together may be an option. They should be 2" diameter and 6" longer than the opening for each side

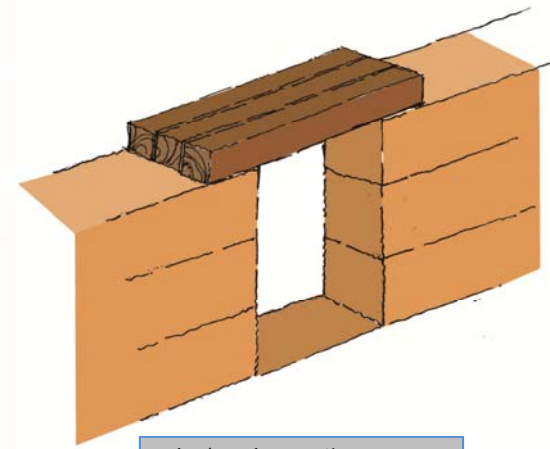

Timber is another option for short span, they should be 6" longer than the opening for each side, and the thickness should be 2"

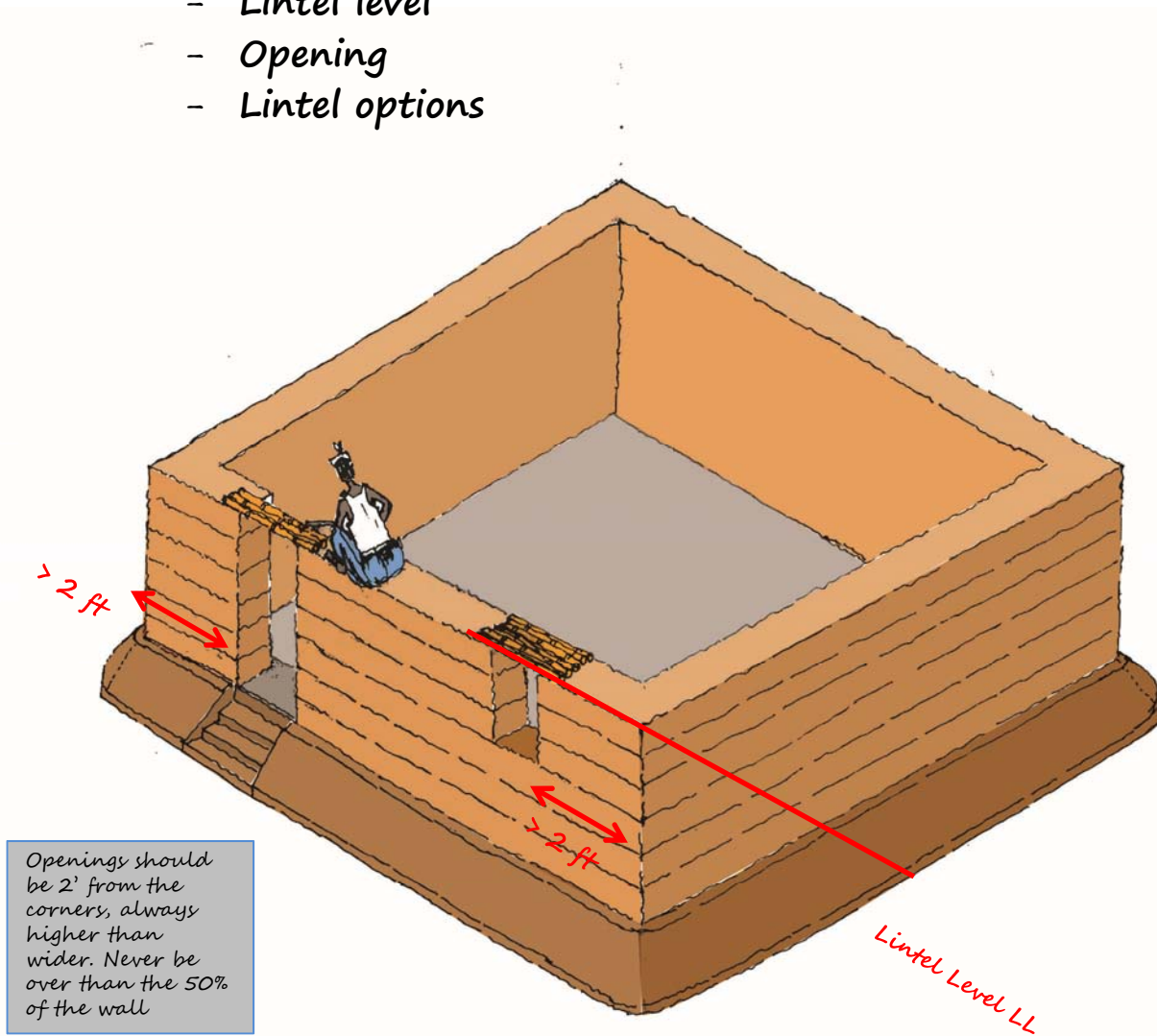

Openings should be 2' from the corners, always higher than wider. Never be over than the 50% of the wall

MUD SHELTER

Phase 4: elevation

- Roof level
- Bearing pad and continuous roof band
- Ventilation

The band at roof level is preferable to the bearing pads, since it is also a seismic DRR

Bearing pads underneath the main beams are the minimum requirement. Timber pads are advisable for mud shelters, but also reinforced concrete pads are an option

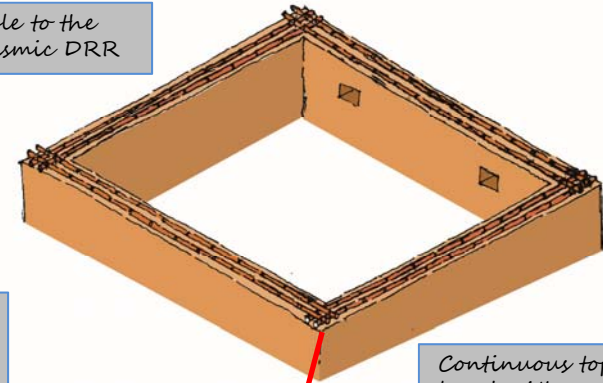
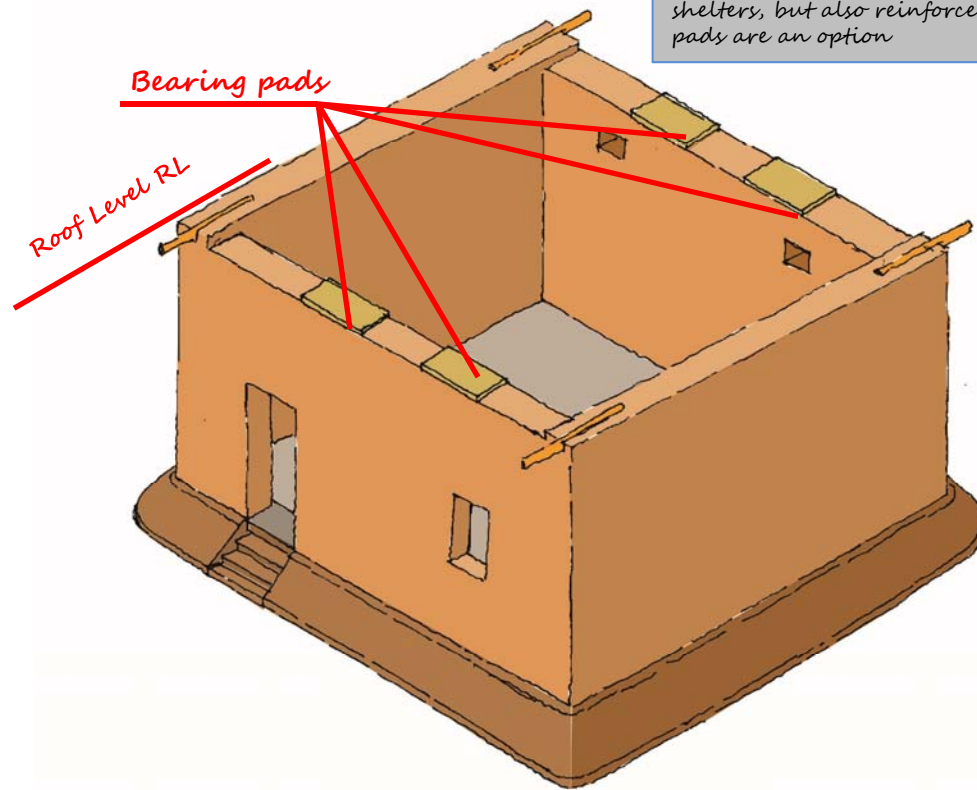

Continuous top band with bamboos

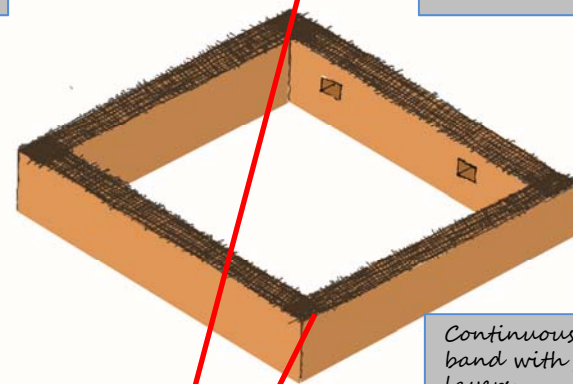

Continuous top band with jute layers

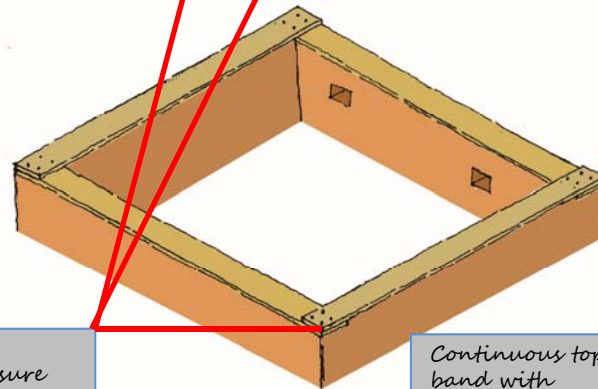

Continuous top band with timber

Overlapping the elements of the reinforcement at the corners, ensure confined action

MUD SHELTER

PHASE 5	ROOF
<i>Generic guidance</i>	<p><i>-Roof design should allow for live and dead loads. Live loads are applied loads such as rain, wind, snow or usage for grain or livestock. Dead loads are those including the makeup of the roof structure such as beams, straw, mud, cement etc.</i></p> <p><i>-A bamboo or other lightweight roof can be used for all construction methodologies, while steel girder roof or similar heavy roof requires a strong bearing structure, therefore it is only suitable for fired brick, concrete block, engineered steel frame shelters.</i></p> <p><i>-A thick mud layer will add a lot of load to the roof and may cause severe, damaging strain to the roof structure and loadbearing walls.</i></p> <p><i>-Timber elements may in some cases be larger loads than steel or other alternatives.</i></p> <p><i>-Bamboo and timber are susceptible to termites. Adequate treatment should be provided to timber and bamboo materials</i></p> <p><i>-Timber, bamboo or straw roofs are not suitable for indoor cooking or heating fires.</i></p> <p><i>-A conical or four-sided pitched roof is preferable in areas where wind loads are a consideration, particularly cyclone vulnerable areas.</i></p> <p><i>-Gable ends or flat surfaces may be more stress by resisting to the wind force</i></p> <p><i>-The pitch of a roof will vary based on the wind conditions in the area, however a maximum pitch is advised of 30° for simple pitched roofs.</i></p> <p><i>-A mono-pitched roof may have a pitch of up to 10° to allow adequate drainage of rainwater.</i></p> <p><i>-In the flat roof a minimum slope should be 3/8" per foot.</i></p>

MUD SHELTER

PHASE 5	ROOF
<i>Main structure</i>	<ul style="list-style-type: none">-A bamboo or other lightweight roof can be used for all construction methodologies.-As main beams three-four bamboos tied together may work. The number of main bamboo beams should be two minimum.-Timber of adequate section and weight may be an option; a bearing pad should be placed underneath.-Steel girder are not advisable, in case a bearing plate has to be insert underneath the girder in order to distribute its load.-The secondary structure of purlin may assembled with well sized bamboos. The distance between bamboos should be not more than 1' (almost 1 brick), their length has to be enough to overlap the thickness of walls.-Above the bamboos a mat of chick, straw, thatch and plastic sheet is generally used. Straw and plastic sheet have to be incorporate in the top of the walls by the final plastering.-Bamboos, timber and straw should be treated against termites.-T-iron and tiles are strongly not advisable for mud walls due the heavy weight.

MUD SHELTER

Phase 5: roof

- Roofing structure: main beams

3 or 4 bamboos tied together may be used as beams for mud shelters. The minimum requirement is two beams, Bearing pads underneath the main beams are compulsory

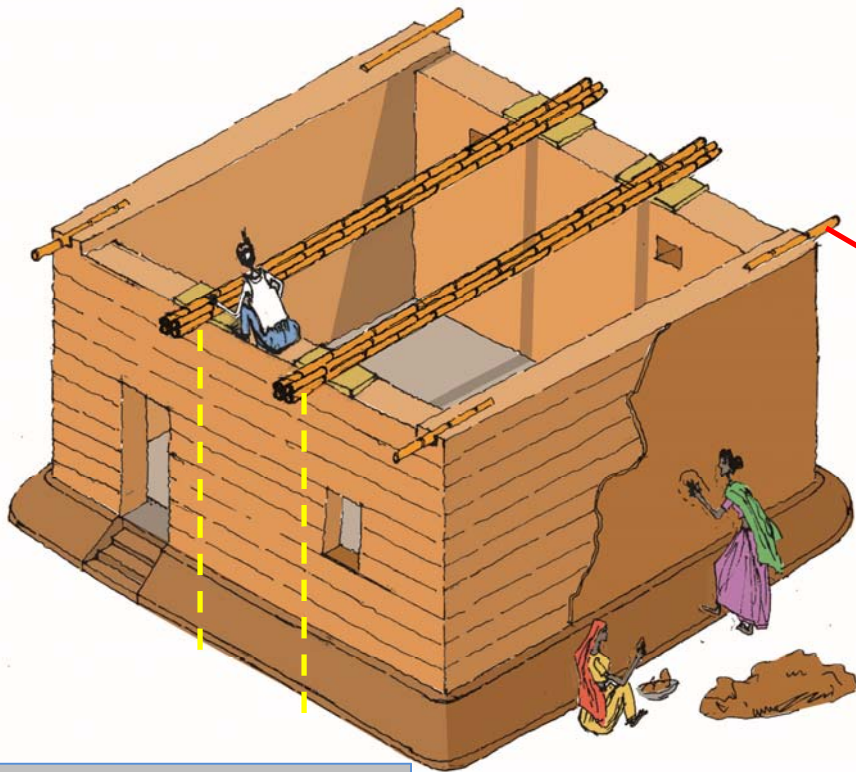

In order to ensure the correct transfer of loads to the bearing walls, beams have to be placed never in line with opening, which are the weak portion of the masonry



Beam section: note the alternate assembling of 4 bamboos according their diameters

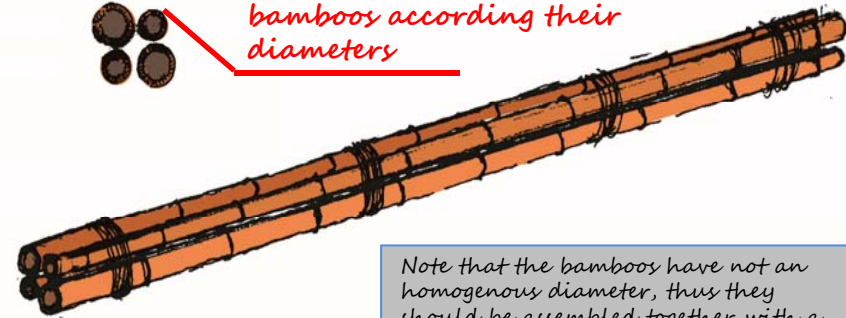

Note that the bamboos have not an homogenous diameter, thus they should be assembled together with a rotation of 180, alternating bigger diameter with smaller.

Eaves or overhang of 15" may prevent rainwater from running down wasting the mud plaster

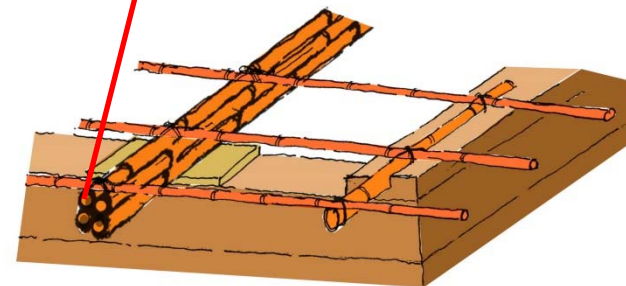

MUD SHELTER

Phase 5: roof

- Roofing structure: main beams

4 beams are preferable and allow to bear also thicker covering packages. Bearing pads underneath the main beams are compulsory

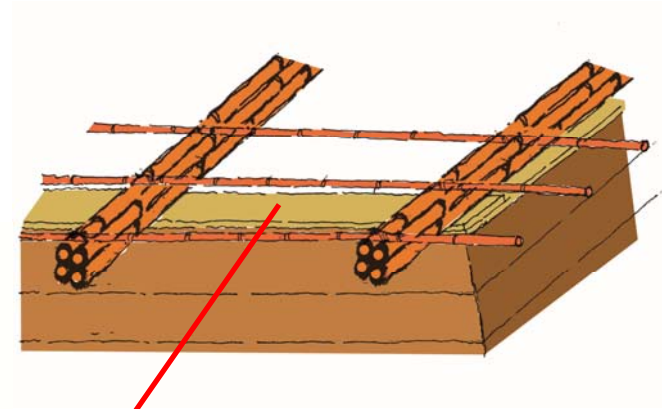
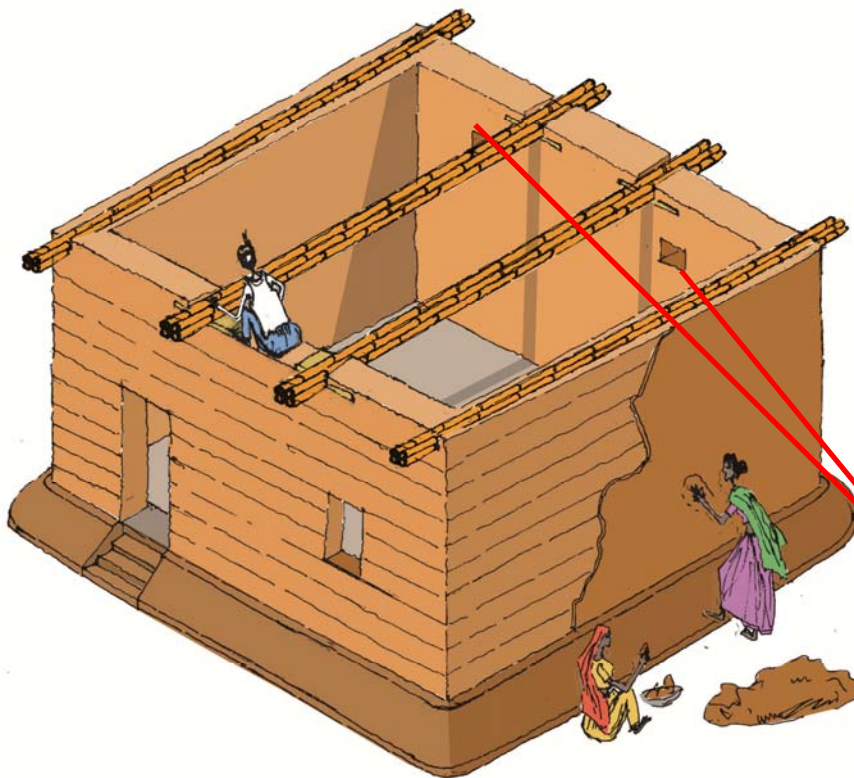

The continuous band underneath the beams is preferable for a better transfer of loads and is a seismic DRR

Remember that the bamboos or timbers have to be treated with anti termite products

Two openings on the back wall can ensure internal ventilation. They may be 2'x 1' or 1'x1', depending on the volume of the shelter.

MUD SHELTER

PHASE 5	ROOF
<p><i>Note and recommendations DRR for earthquake resistance</i></p>	<ul style="list-style-type: none"> -All loadbearing elements of the roof structure, columns, beams and joists have to be not placed above door or window openings. Any openings provide weaknesses in the walls, because reduce the portion of bearing walls, thus placing the loadbearing elements right above the openings may cause failure in the walls with cracks and even collapse of the portion interested. -Any elements of the roof structure should be tied to each other. All joists or beams in the roof structure need to be individually tied to purlins. Well fastening ensure a good resistance to the strong wind and is a kind of DRR against earthquake. -The roof must also be securely tied to the wall structure. -Roofs have different load distribution arrangements, as the concentration of loads underneath the beams, thus in order to distribute equally the roof loads a top plate/band or ring beam should be provided at the top of the walls. It should be continuous encircling the walls, this provides a way of fastening the walls together at the top to prevent pushing outward forces of the roof and in case of horizontal seismic forces. -In case of pitched roof with two gables, placing plates/bands at the top of the wall (without gables) distribute the loads and constrains the pushing forces of the rafters. -It is suggested to assemble trusses instead of rafters, since the horizontal bottom chord ties the inclined top chords constraining their pushing outward forces.

MUD SHELTER

Phase 5: roof

- Roofing structure: purlins

The secondary structure of purlins may be done with bamboos of minor diameter i.e. 2". The distance between the purlins should be maximum 1', a brick may be used to interspace them

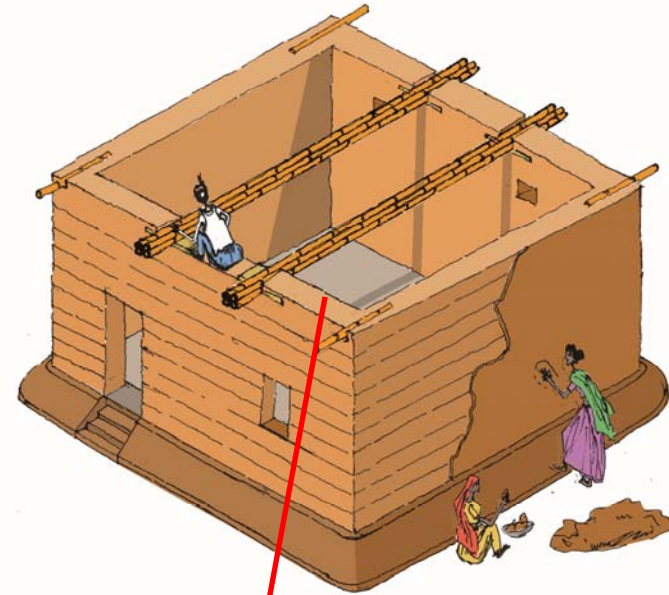
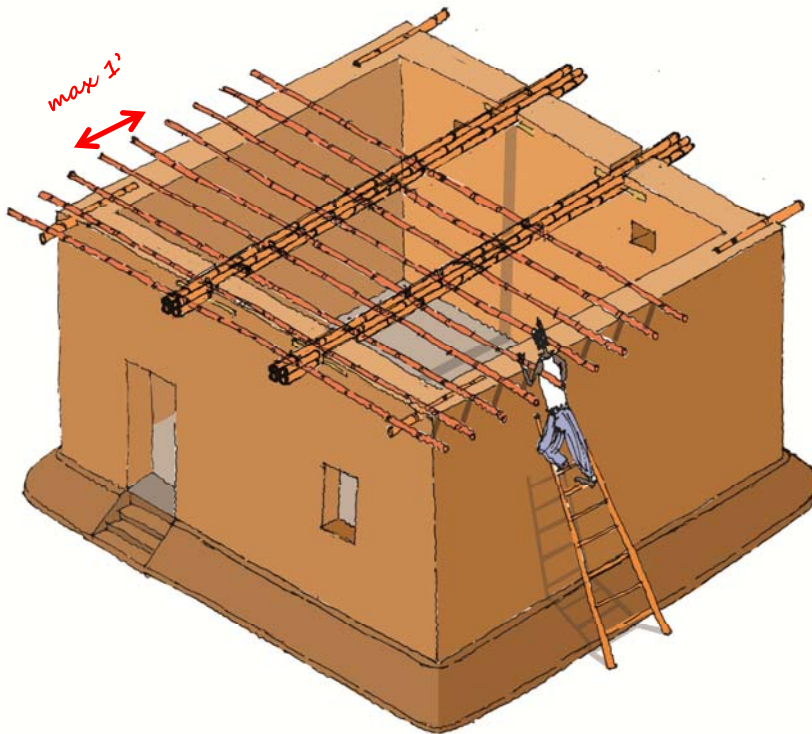

No gaps should be between the walls and the roof

MUD SHELTER

Phase 5: roof

- Roofing structure: options

Although it is not recommended, another solution preferred by the beneficiaries is girder as main structure for the roof. The reasons why girders are preferred is because it is perceived as durable highly resistant material and can be saved in case of collapse, furthermore it is not affected by termites and other insects

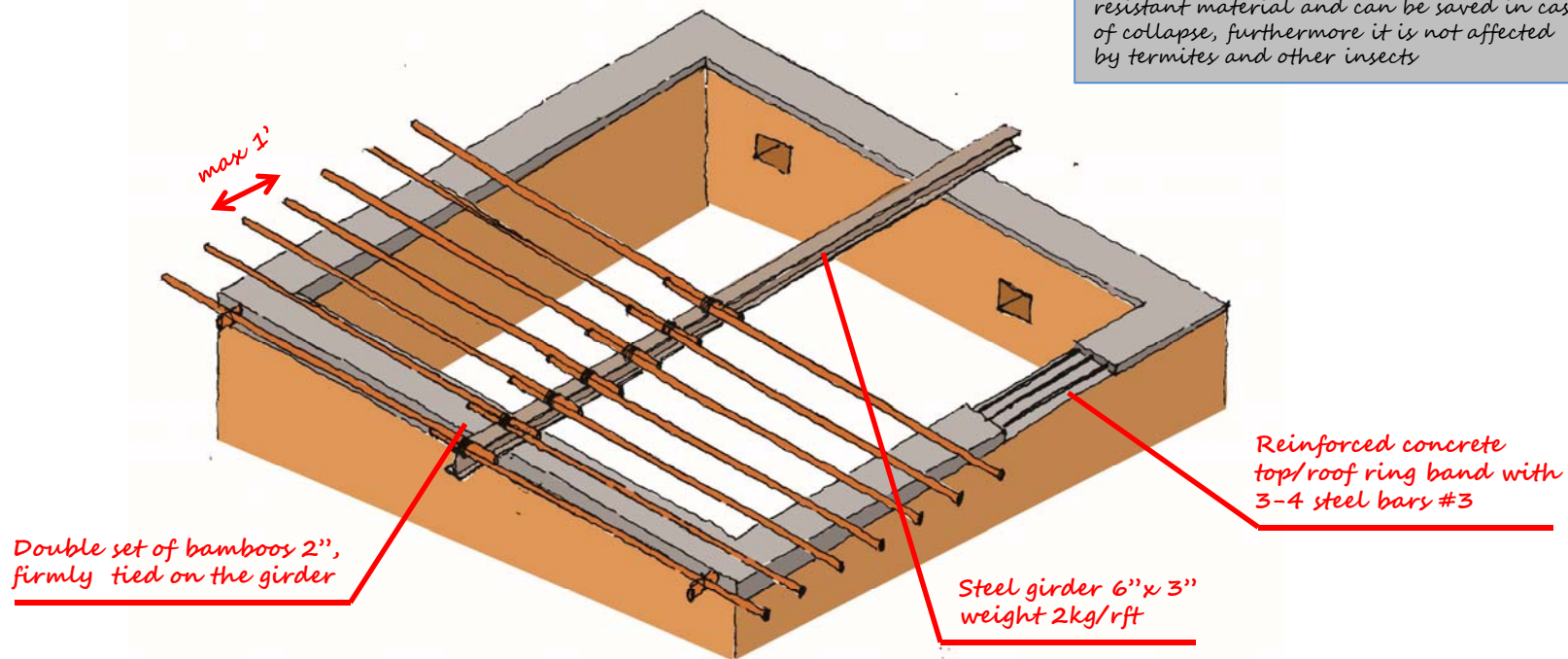

Double set of bamboos 2", firmly tied on the girder

Steel girder 6"x 3" weight 2kg/rft

Reinforced concrete top/roof ring band with 3-4 steel bars #3

Due to its higher weight it is compulsory to execute the roof ring band in reinforced concrete. As alternative at least longer bearing pads. The secondary structure of purlins may be consist in a double set of bamboos, this allows also to select their right size

The girder has to be treat with anticorrosive solution to prevent the rust

MUD SHELTER

PHASE 5	ROOF
<p><i>Covering package Generic guidance</i></p>	<ul style="list-style-type: none"> -Roof topping can be made with many different materials as long as the items are lightweight, strong, durable, secured, waterproof, insulating and maintainable. -A common practice is the use of a thatch or other structural system, plastic sheeting with a mud plaster layer, protected with a final waterproofing layer. -Any material that soak water or melt should be avoided. -Lime plaster or a bitumen mixture may provide a water-resistant finish to the roof that should be reapplied prior and after annual rains.
<p><i>Covering package Specific guidance</i></p>	<ul style="list-style-type: none"> - Above the semi structural mat of straw or thatch, a polythene sheet, a layer of stabilized mud have to be applied in 2-3 coats, the thickness may be 3” maximum. Thicker mud layer may make heavy the structure. -The last coat should be a waterproof one. Lime /mud plaster may improve the water resistance. -Bitumen mixed with stabilized mud mortar is an effective treatment, it is waterproofing and fire resistant. It should be prepared by mixing (5:1) bitumen with kerosene oil and mud (1.5 kg of bitumen for 30 kg of mud), shoveled thoroughly. -Also animal dump, mixed with mud, may be a kind of waterproofing as an eco-friendly option. -In case of flat roof, the coats of plaster have to incorporate the top of the walls and the parapet, protecting the matting of plastic sheet and straw and the structure of roof, as a kind of waterproofing capping. This is a DRR that will avoid the rain water to penetrate in the connection roof/walls.

MUD SHELTER

Phase 5: roof

- Roofing cover
- DRR measures

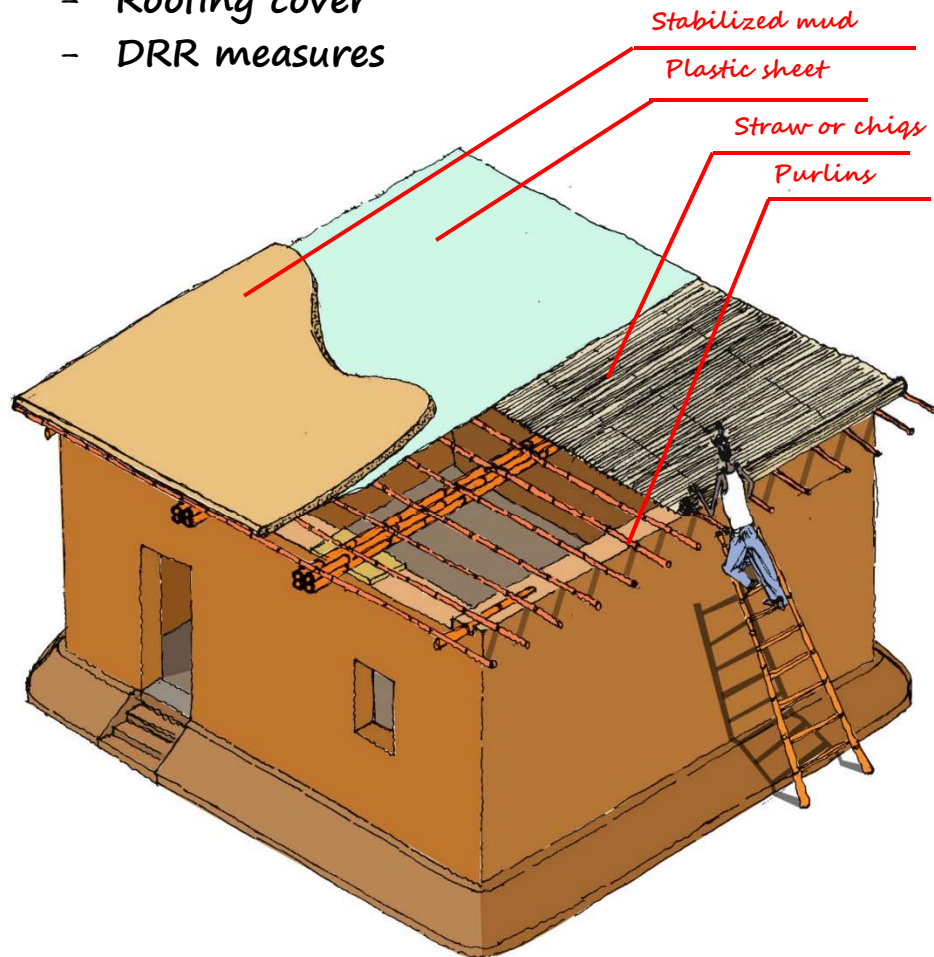

Covering package may be executed with straws or chigs, polythene sheet and 2-3 coats of mud. The maximum thickness of the mud should be 3'' in order to avoid heavy loads on the beams and the walls

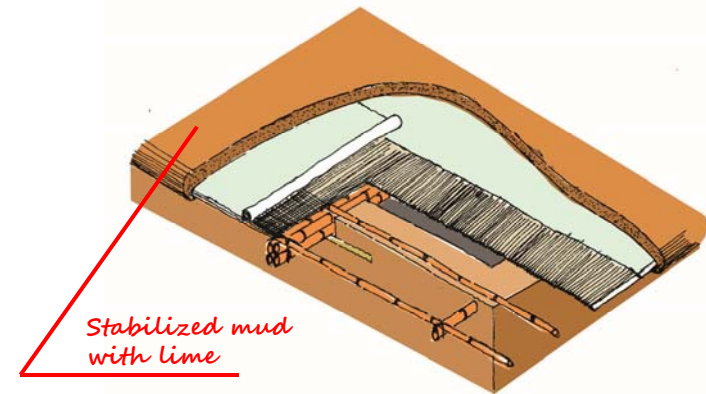

The covering package with straw, plastic sheet and 2-3 coats of mud. The last layer has to ensure waterproofing protection to the roof. It may be with stabilized mud with lime. The thickness should be 3'' maximum

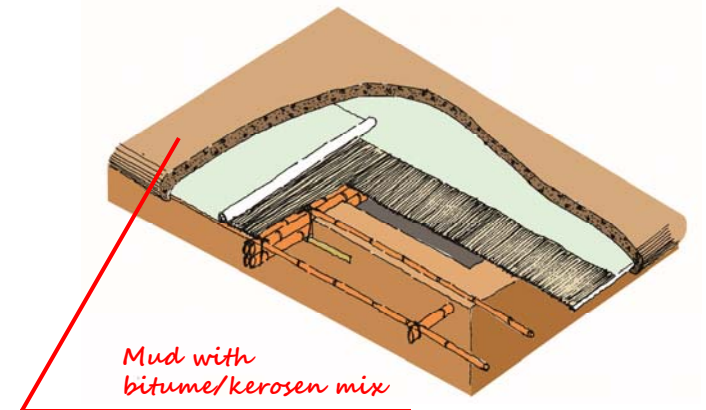

Another option for the last waterproofing layer may be adding bitumen mixed with kerosene to the mud. The thickness may be less than 3''

MUD SHELTER

PHASE 5	ROOF
<p><i>DRR waterproofing and drainage</i></p>	<ul style="list-style-type: none"> -An overhang of the roof, or eaves, of 15" minimum will prevent rainwater from running down mud or plaster of the walls and soaking into the structure and splash the plinth. This will aid the structures resilience. -For flat roof it is important a right slope to allow the rain water to wash away quickly, the stagnancy upon the roof allows the rain water soaking the top layers and penetrate in the core of walls. -Where there is a parapet is compulsory to provide 1 or 2 waterspouts, the slopes have to be arranged accordingly (minimum 1%). -The waterspouts should be minimum 2.5" and project minimum 8". -The waterspouts have to be well sealed with bitumen without any discontinuity in order to prevent water rain to penetrate in the structure of roof and walls above. -Another option may be CGI spout in "U" shape. -The use of gutters for catch rain water may be considered; obviously the slope has to be adequate in case of flat roof.
<p><i>Maintenance</i></p>	<ul style="list-style-type: none"> -Re-plaster with lime mud or bitumen mud mortar the roof at least once an year before the monsoon season or whenever necessary. -Periodic cleaning of the waterspouts. -Re-apply the film of bitumen yearly before the monsoon season -Verify the good connection between the elements of the structures (beams and purlins) -Re-treat against termite the bamboos and wooden elements once an year or whenever necessary. -Inform the owners regarding periodic treatments as termite treatment, annual re-plastering of roof and walls, periodic cleaning of the waterspouts.

MUD SHELTER

Maintenance :

- DRR
- Waterproofing plaster
- Roofing cover

Maintenance of the structure and DRR ensures a longer and safer life of the shelter. The main treatments to be applied periodically, i.e. yearly, are:

- Re-plastering before the raining season
- Verify and re-apply the waterproof layer of bitumen of stabilized mud till the SL
- Verify and reply the waterproof layer of the roof
- Control the connection of the main structure of the walls
- Repair all the cracks that may be appear on the walls due to ground settlement and or to the dry weather

Obviously al the damages that might occur should be repaired without hesitation

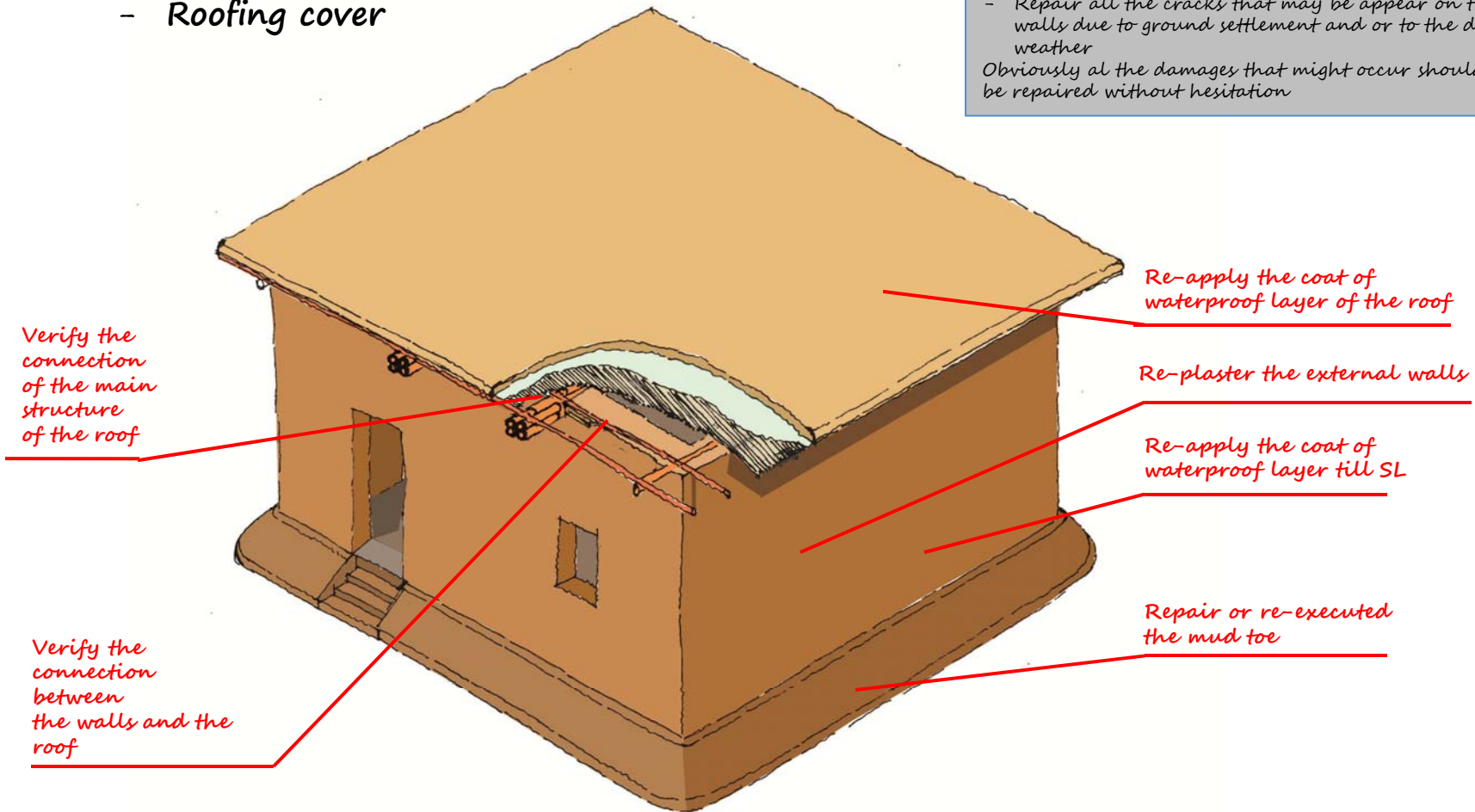

ONE ROOM SHELTER ADOBE

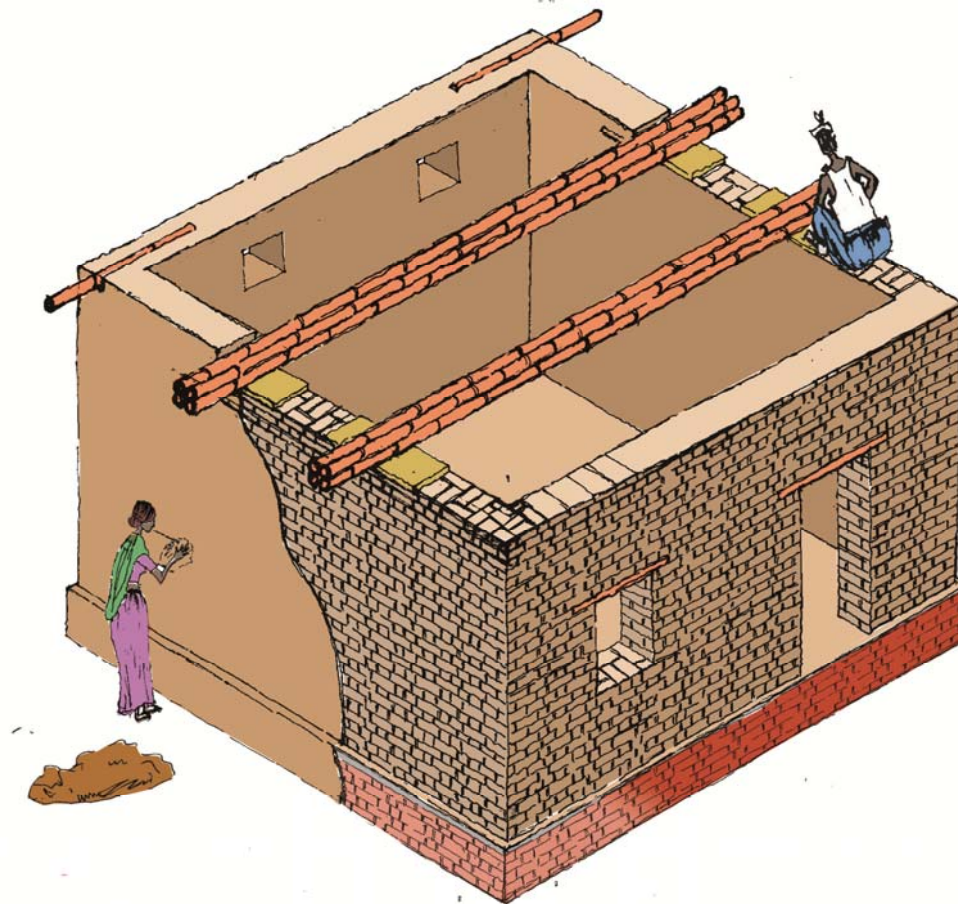

ADOBE SHELTER

Walls of adobe houses are constructed with sun dried bricks/blocks laid in mud mortar. The foundation and the raised plinth should be in fired brick masonry and cement sand mortar as DRR.

The thickness of the walls has to be 13.5” minimum, increasing it up to 18” improves the stability and the DRR against earthquake.

DRR measure against flood is plastering the walls, external and internal, with stabilized mud or a mixture of mud bitumen and kerosene, at least until the sill level. The whole plastering till the roof level ensure a better protection against to rain-flash too. The same DRR has to be applied above the roof, ensuring continuity between the roof application and the plastering of the walls. The eaves may protect the walls from the eroding action of the rain.

DRR for the earthquake resistance may be a reinforcement with a vertical frame of fired bricks, at the corner and reinforced bands at floor, sill, lintel and roof level. The roof band is always suggested.

ADOBE SHELTER

PHASES 1 and 2	EXCAVATION, BEARING FOUNDATIONS AND FOUNDATIONS
<i>Generic Guidance</i>	<ul style="list-style-type: none"> -Foundations and platforms specification, depth and height, depend on the site characteristics (soil, elevation) and super structure, materials and loads, thus their depth and width have to be designed on a case by case basis. -The excavation depth may be more than 2' - 3' in not compacted soils. -Generally the width of the platform should be almost one third for each side=1.6-2 times the thickness of the walls. -The foundations need to have a sealed barrier at the base to prevent that the water penetrates into the structure both from the ground (dampness) either from stagnancy. -Reinforcing the walls at ground level by adding concrete plaster /pointing layer or mud / lime may be an option. -Increasing the width of walls at the base will improve resilience against stagnant flood water and extend or prevent the time of disintegration (depending on the time of stagnancy).
<i>Specific Guidance</i>	<ul style="list-style-type: none"> -Excavation depth has to be minimum 18" below undisturbed ground or compacted soil. -If there is a skeleton (wall columns), it needs to penetrate to a minimum of 18" in the ground, reaching the solid layer; they have to be reinforced with cement or lime / mud posts, to ensure stability. -Minimum dimensions for foundations are 2.5'wide footings founded 2' below the Natural Surface Level (NSL); dimensions may increase with mud mortar.
<i>Notes and recommendations</i>	<ul style="list-style-type: none"> -A tapered foundations may better distribute the load to the ground. -The foundations can be in stones, in fired bricks in concrete; cement/sand mortar is preferable. - Adobe brick are not suggested for the foundations, but in case cement mortar has to be used and they have to be plastered with cement/sand/lime for waterproofing purposes. -Wall columns in fired bricks may reinforce the structure (DRR against earthquake). -When the adobe has a skeleton, appropriate anchoring details for the foundation should be considered.

ADOBE SHELTER

Phase 1: excavation - Excavation

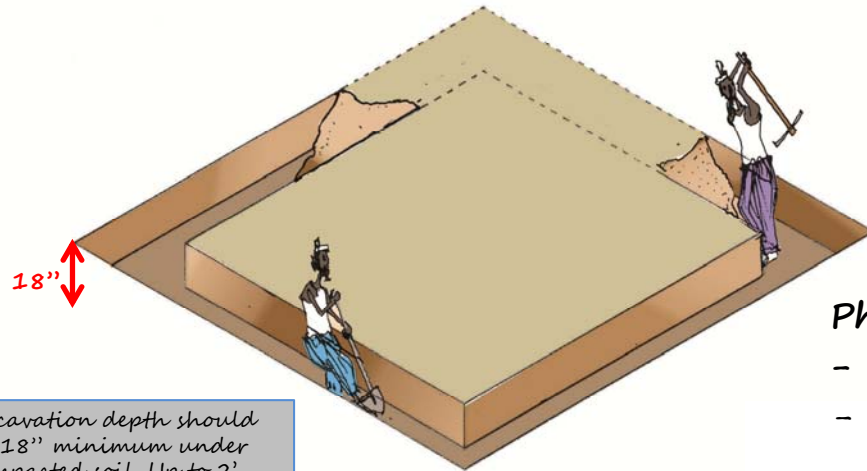

Excavation depth should be 18" minimum under compacted soil. Up to 2' - 3' when not compacted

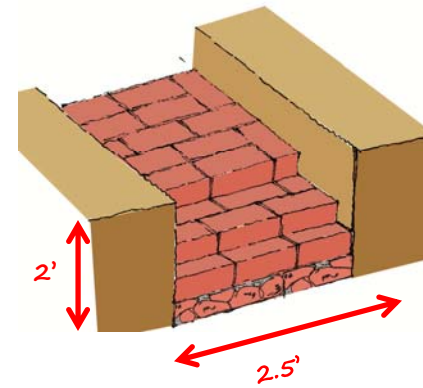

Phase 2: foundation - Bearing foundation - Foundation

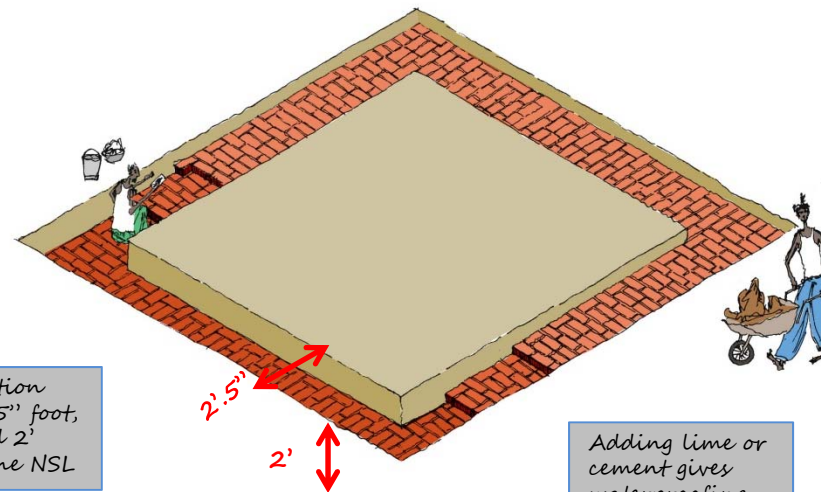

Foundation with 2.5" foot, founded 2' below the NSL

Adding lime or cement gives waterproofing resistance

ADOBE SHELTER

PHASES 3	RAISED PLINTH FLOOR
<i>Generic Guidance</i>	<ul style="list-style-type: none"> -The floor level should be raised to at least 1'6" up to 3' above the Natural Surface Level (NSL) adopting a continuous plinth. -General recommendation is to protect furthermore the foundations below floor level by raising an earth platform 3' wide at the top and tapering to NSL over 6'. (i.e 1 in 2 slope minimum.) The top of this platform should be 6" below floor level. -A damp proof course (DPC) at plinth level is compulsory in order to prevent moisture rising into the walls. A DPC is either a thin layer of concrete at plinth level with plastic on one surface or simply a strong plastic layer.
<i>DRR improvements (Flood and earthquake)</i>	<ul style="list-style-type: none"> -The plinth may be in stones, in fired bricks in concrete, cement/sand mortar has been used. -At the top the plinth a reinforce band with 2 bars can ensure the earthquake resistance, in case of concrete plinth it may be reinforced with 4 bars.
<i>Maintenance</i>	<ul style="list-style-type: none"> -Re-plaster with lime/mud/cement mortar the raised plinth at least once yearly, before the monsoon season, and whenever necessary. -In case of reinforced band: verify that the bars are not expose and corroded, paint them with red oxidant varnish.

ADOBE SHELTER

- Phase 3: raised plinth
- Execution of plinth
 - DPC

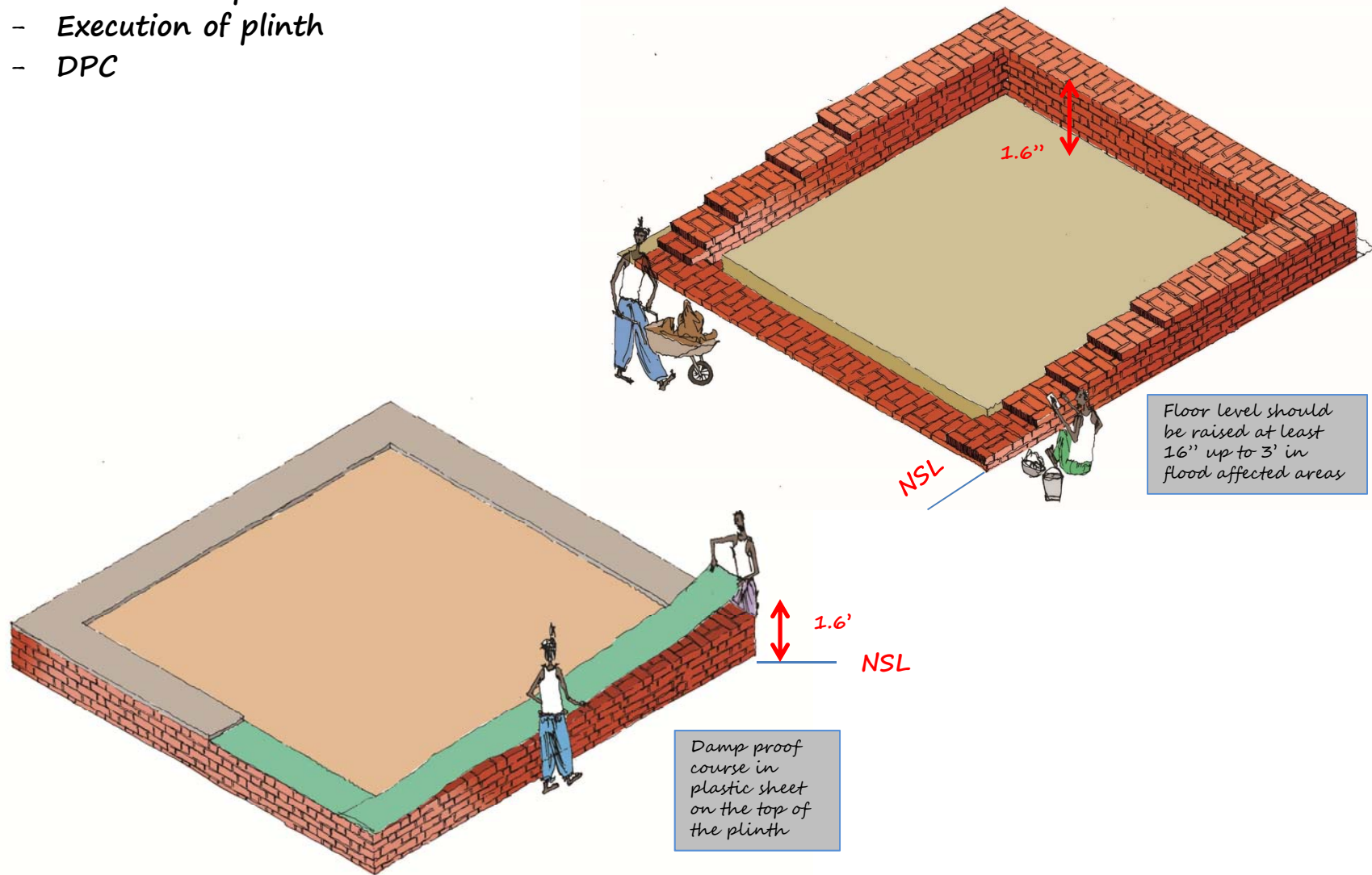

ADOBE SHELTER

Phase 3: raised plinth

- Details
- DRR measures for reinforcement

Foundations and plinth are suggested to be in fired bricks and cement mud as DRR flood resistant

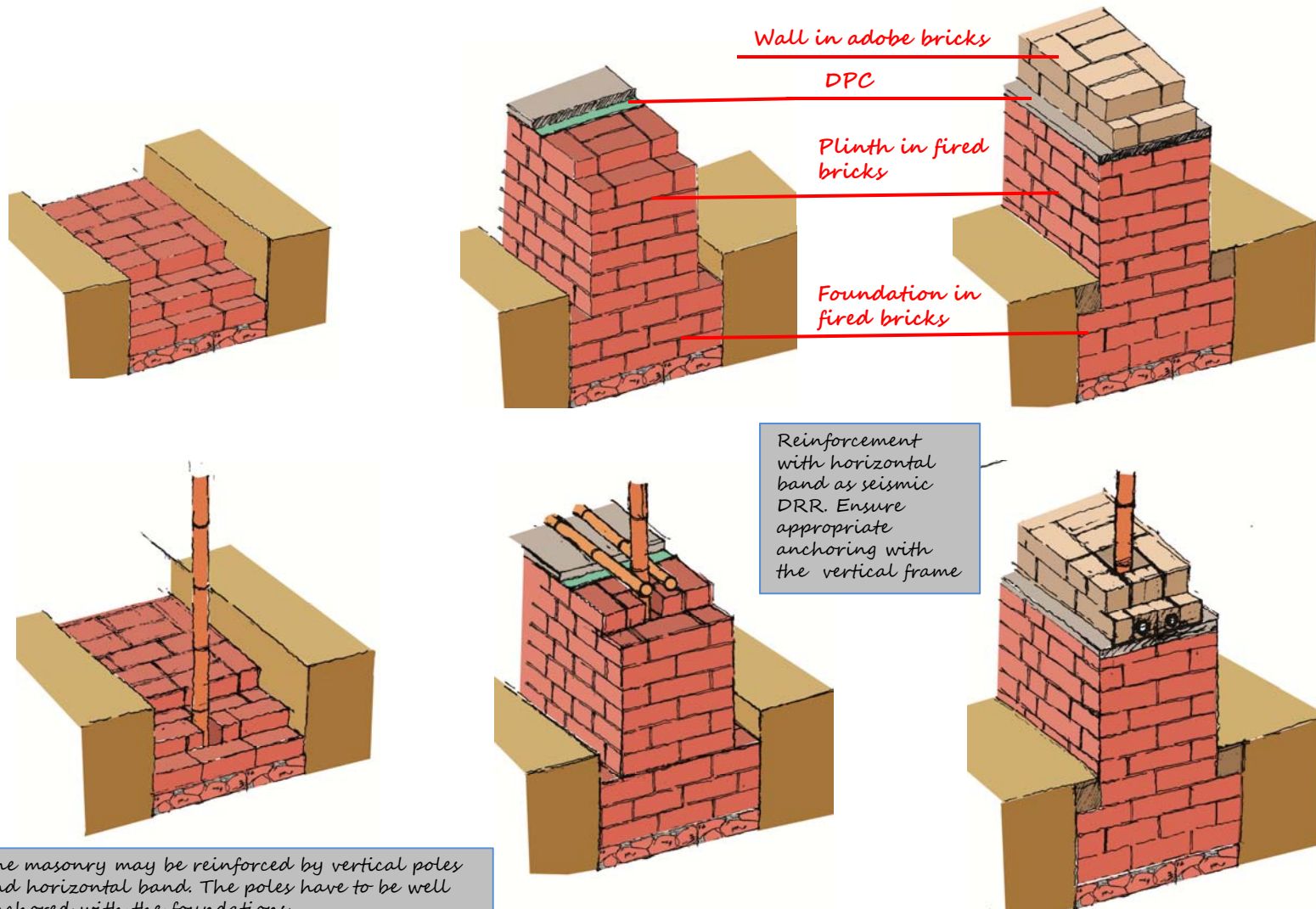

The masonry may be reinforced by vertical poles and horizontal band. The poles have to be well anchored with the foundations

ADOBE SHELTER

PHASES 4	SUPERSTRUCTURE
<p>Walls Core materials and techniques</p>	<ul style="list-style-type: none"> -Adobe brick construction should not be built less than 13.5" thick, in order to provide resilience and distribution of the loads from roof to ground. -The good execution reduces the weaknesses. Good advice is to start building the walls from the corners, and get the bond correctly, since weak corners make the shelter vulnerable. -Lime and cement should be added to the mud mortar to increase the bonding capacity and the waterproofing.
<p>Notes and recommendations</p>	<ul style="list-style-type: none"> -In order to improve the durability it may be used fired bricks for the external face of walls only till the sill level and the adobe brick for the internal. The thickness will be minimum 13.5" as well. -Another solution may be to use fired bricks walls (full wall) till the sill level and above with the adobe. This increases the bearing capacity and waterproof resistance. -If only adobe brick are available, in order to improve the stability and durability of the shelter, it may be increased the thickness at the base of walls, till sill level, up to 18" -Cement-lime-sand mortar is preferred to the mud mortar, although the walls have to be plastered always.
<p>DRR for earthquake resistance Joint and binding Reinforced bands</p>	<ul style="list-style-type: none"> -Suitable interlocking of adobe bricks should be provided to ensure stability and durability of walls and provide earthquake resistance. -In order to reinforce the corners, the wall rows may be overlapped and projected at the corners, this provides such a buttress. Also increasing the thickness at the corners provides buttresses -It is also recommended to use fired bricks as columns for the corners and openings of an adobe structure. -Steel bars may be used as vertical reinforcements at the corners and junctions.

ADOBE SHELTER

Phase 4: elevation

- Sill level
- Reinforcement

Adobe walls should be not less than 13.5" thick. Increasing the thickness of 18" at the base till the sill level, improve the stability thus is a DRR against the earthquake

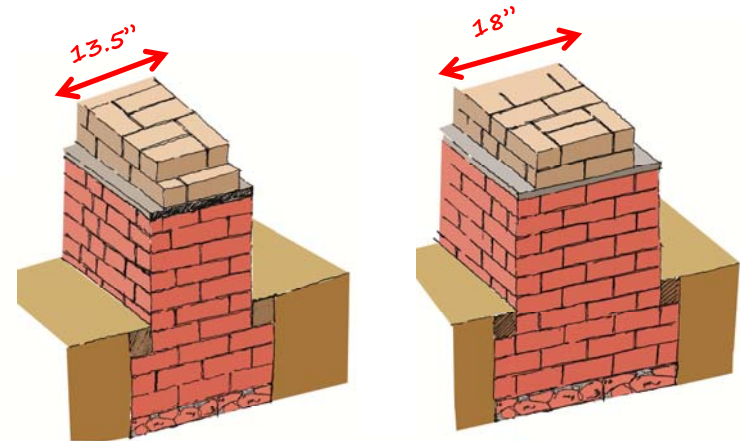
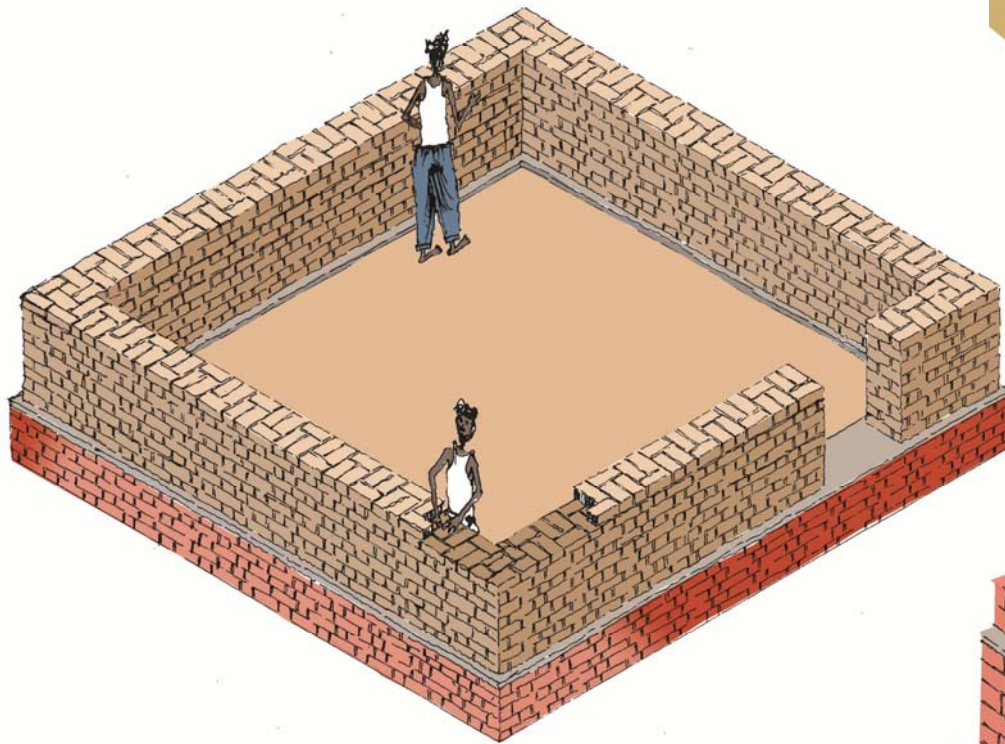

Floor level band is a DRR against earthquake. It may be executed with reinforced concrete, with 3 bars # 4

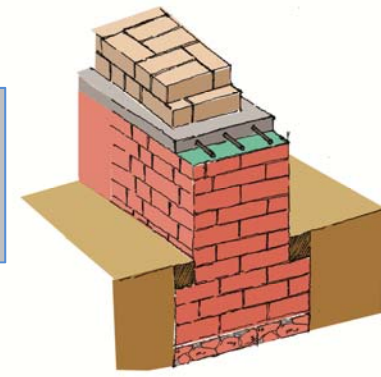

A good practice as DRR measures against the flood is using fired bricks with cement/sand mortar for the external side of walls, at least till the sill level

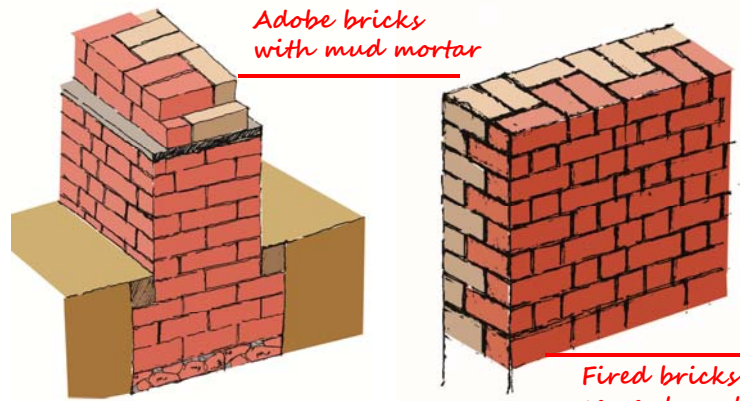

ADOBE SHELTER

PHASES 4	SUPERSTRUCTURE
<p><i>DRR flood resistance (plaster as protective and expendable surface)</i></p>	<ul style="list-style-type: none"> -Adobe has poor water resistance thus the external walls have to be protected, thus adobe shelter has to be completely plastered externally, while internally at least till the sill level. -A protective layer is compulsory for the external walls and suggested for the internal. -A protective layer has to be applied at least till 3' above the ground level (better sill level). -The protective layer may be an eco-friendly one as lime-mud mixture, or animal dung mixed with mud, or in alternative a film of bitumen mixed with kerosene oil. -Bitumen with stabilized mud mortar is an effective treatment, it is waterproof and fire resistant. It should be prepared by mixing bitumen with kerosene oil (5:1) and mud (1.5 kg of bitumen for 30 kg of mud) shoveled thoroughly. -Above the sill level the use of lime-mud plaster (1 : 3 mixture) may improve the waterproof resistance to the inner of the upper structure. -The coats have to be 2- 3 applied by curing and in sequence till the roof level.
<p><i>Maintenance</i></p>	<ul style="list-style-type: none"> -Re-plaster with lime/mud/cement mortar the raised plinth at least once an year before the monsoon season, and whenever necessary (worn-out plaster). -Re-apply the protective film (mixture with lime, or animal dung, or bitumen) at least once an year before the monsoon season or when worn-out. -In case of reinforced band: verify that the bars are not expose and corroded, paint them with red oxidant varnish.

ADOBE SHELTER

Phase 4: elevation

- DRR measures
 - Reinforcement at corners
 - Plastering

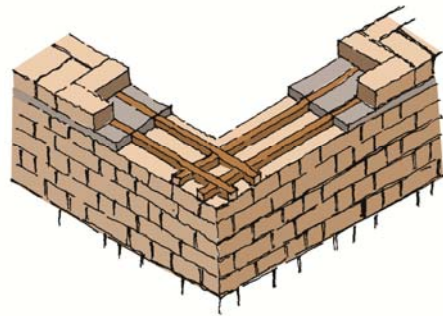

Timbers or bamboos are options. They should be inserted every 2.5' - 3' overlapped at the corner

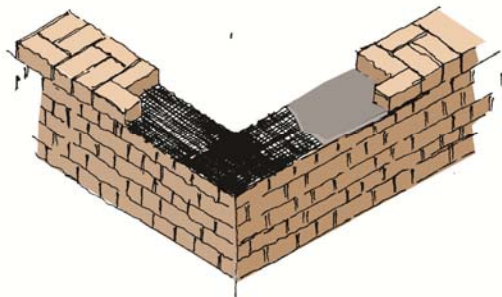

Wire mesh is also an option, if protected by a cement casting. Also this reinforcement should be provided at least every 3'

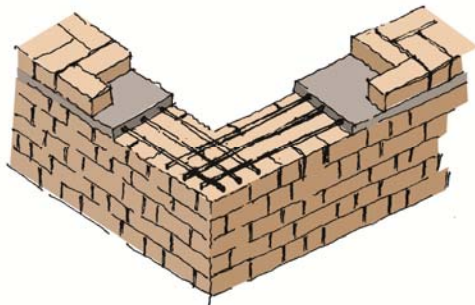

Reinforced concrete corners may be a good option if the bars are well displaced and protected by the cement. They should be provided every 3' and joined with stitches

Plastering externally the walls is compulsory, the internal plaster is also a good practice as DRR in order to protect the adobe from the erosion caused by the stagnant water.

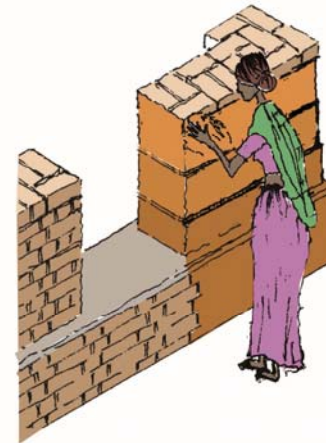

Waterproof measure is applying a lime-mud mix (1:3) plaster at least till the sill level. The coats should be 3



Adding lime or cement to the mud mortar gives waterproofing characteristic. It is suggested to use this improved mortar at least till the sill level, which is the flood level too

Bitumen mixed with kerosene and stabilized mud plaster may be a valid option

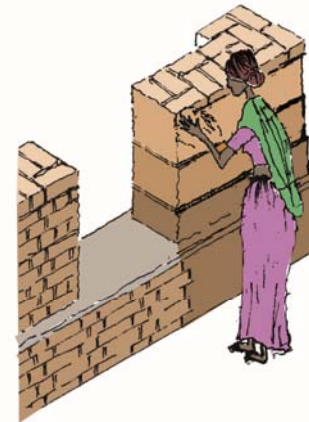

ADOBE SHELTER

PHASES 4	SUPERSTRUCTURE
<i>Opening door window</i>	<ul style="list-style-type: none"> -Openings within the wall space should not take up an area greater than 50% of the wall. -Openings should be higher than wider -Windows and doors should be kept a minimum of 2 ft from corners and from each other -The doors should open outwards for fire safety purpose
<i>Lintels</i>	<ul style="list-style-type: none"> -Lintels have the function to bear and distribute the load of the wall above the openings -Lintels should be designed based on the load being carried overhead -Lintels should be minimum 2'' thick and 6'' longer than the opening for each side -For short spans timber plate or tied bamboos (2-3) may be an option, which sounds more appropriate to the mud structure -The lintel may be executed with bricks system using n.2 steels #3 and cement mortar -The pre-cast concrete lintel may be a good option
<i>Ventilation</i>	<ul style="list-style-type: none"> -Ventilation is very important mainly during the summer, that is very hot in several areas -Two windows may ensure ventilation. Alternatively one or two ventilators, executed on the opposite side of the window (generally on the back wall) may ensure a good ventilation -The dimensions depend on the size of the shelter, it may be one of 2' x 1' or two 1'x1' -In some areas, where the summer is very hot, it may be suggested to increase the height of the shelter to improve the internal ventilation (in this case the entire structure of the shelter has to be re-calculated)

ADOBE SHELTER

Phase 4: elevation

- Lintel level
- Opening
- Details and options of lintels

Lintels should be designed accordingly the loads carried overhead

Bamboos tied together may be an option. They should be 2" diameter and 6" longer than the opening for each side

Timber is another option for short span, they should be 6" longer than the opening for each side, and the thickness should be 2"

Lintel may be executed with 3 steel bars # 2 and cement. Pre-cast concrete may be an option

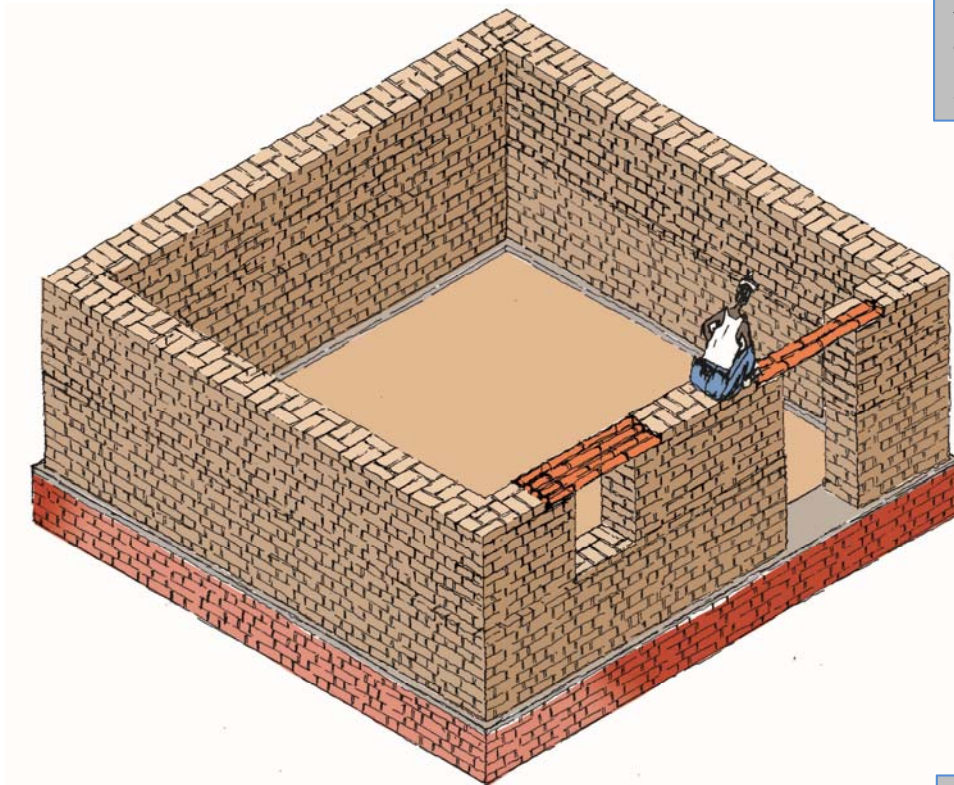

Openings should be 2' from the corners, always higher than wider. Never be over than the 50% of the wall

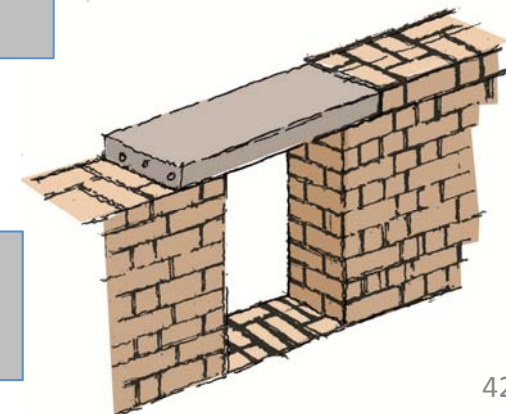
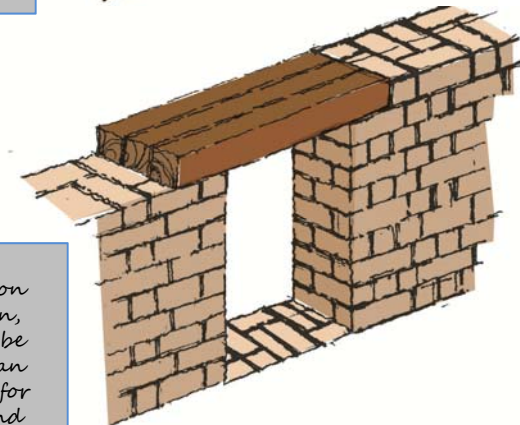
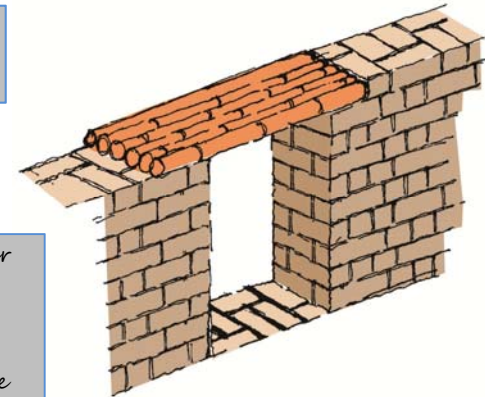

ADOBE SHELTER

PHASES 5	ROOF
<p><i>Generic guidance</i></p>	<ul style="list-style-type: none"> -Roof design should allow for live and dead loads. Live loads are applied loads such as rain, wind, snow or usage for grain or livestock. Dead loads are those including the makeup of the roof structure such as beams, straw, mud, cement etc. -A bamboo or other lightweight roof can be used for all construction methodologies, while steel girder roof or similar heavy roof requires a strong bearing structure, therefore it is only suitable for fired brick, concrete block, engineered steel frame shelters. -A thick mud layer will add a lot of load to the roof and may cause severe, damaging strain to the roof structure and loadbearing walls. -Timber elements may in some cases be larger loads than steel or other alternatives. -Bamboo and timber are susceptible to termites. Adequate treatment should be provided to timber and bamboo materials -Timber, bamboo or straw roofs are not suitable for indoor cooking or heating fires. -A conical or four-sided pitched roof is preferable in areas where wind loads are a consideration, particularly cyclone vulnerable areas. -Gable ends or flat surfaces may be more stress by resisting to the wind force -The pitch of a roof will vary based on the wind conditions in the area, however a maximum pitch is advised of 30° for simple pitched roofs. -A mono-pitched roof may have a pitch of up to 10° to allow adequate drainage of rainwater. -In the flat roof a minimum slope should be 3/8" per foot.

ADOBE SHELTER

PHASES 5	ROOF
<p><i>Main structure</i></p>	<ul style="list-style-type: none"> -A bamboo or other lightweight roof can be used for all construction methodologies. -As main beams three-four bamboos tied together may work. The number of main bamboos beams should be two minimum. -Timber of adequate section and weight may be an option; a bearing pad should be placed underneath. -Steel girder are not advisable, in case a bearing plate has to be insert underneath the girder in order to distribute its load. -The secondary structure of purlin may assembled with well sized bamboos. The distance between bamboos should be not more than 1' (almost 1 brick), their length has to be enough to overlap the thickness of walls. -Above the bamboos a mat of chick, straw, thatch and plastic sheet is generally used. Straw and plastic sheet have to be incorporate in the top of the walls by the final plastering. -Bamboos, timber and straw should be treated against termites. -T-iron and tiles are strongly not advisable for mud walls due the heavy weight
<p><i>Note and recommendations DRR for earthquake resistance</i></p>	<ul style="list-style-type: none"> -All loadbearing elements of the roof structure, columns, beams and joists have to be not placed above door or window openings. Any openings provide weaknesses in the walls, because reduce the portion of bearing walls, thus placing the loadbearing elements right above the openings may cause failure in the walls with cracks and even collapse of the portion interested. -Any elements of the roof structure should be tied to each other. All joists or beams in the roof structure need to be individually tied to purlins. Well fastening ensure a good resistance to the strong wind and is a kind of DRR against earthquake. -The roof must also be securely tied to the wall structure. -Roofs have different load distribution arrangements, as the concentration of loads underneath the beams, thus in order to distribute equally the roof loads a top plate/band or ring beam should be provided at the top of the walls. It should be continuous encircling the walls, this provides a way of fastening the walls together at the top to prevent pushing outward forces of the roof and in case of horizontal seismic forces. -In case of pitched roof with two gables, placing plates/bands at the top of the wall (without gables) distribute the loads and constrains the pushing forces of the rafters. -It is suggested to assemble trusses instead of rafters, since the horizontal bottom chord ties the inclined top chords constraining their pushing outward forces.

ADOBE SHELTER

Phase 5: roof - Roofing structure

3 or 4 bamboos tied together may be used as beams for mud shelters. The minimum requirement is two beams, Bearing pads underneath the main beams are compulsory

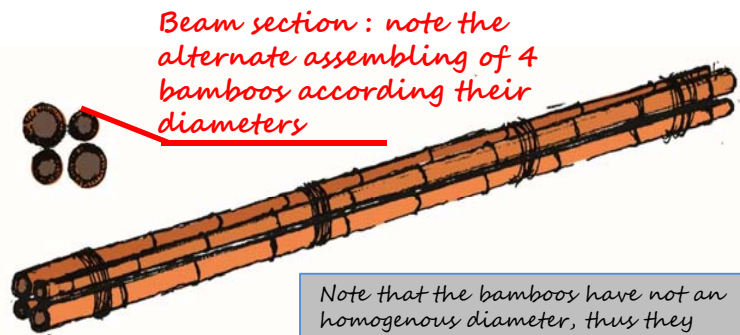

Beam section: note the alternate assembling of 4 bamboos according their diameters

Note that the bamboos have not an homogenous diameter, thus they should be assembled together with a rotation of 180, alternating bigger diameter with smaller.

Two openings on the back wall can ensure internal ventilation. They may be 2' x 1' or 1' x 1' depending on the volume of the shelter

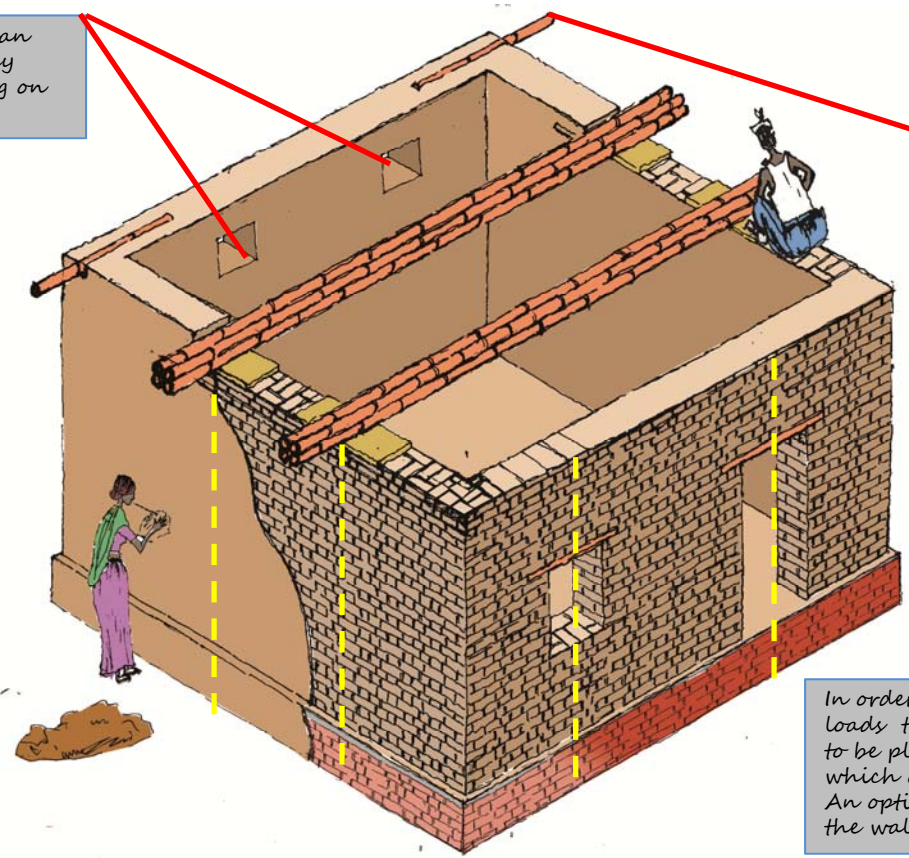

Eaves or overhang of 15" may prevent rainwater from running down wasting the mud plaster

In order to ensure the correct transfer of loads to the bearing walls, the beams have to be placed not in line with opening, which are the weak portion of the masonry. An option may be to place the beams above the walls without openings.

ADOBE SHELTER

Phase 5: roof

- Roofing structure and options

The secondary structure of purlins may be done with bamboos of minor diameter i.e. 2". The distance between the purlins should be maximum 1', a brick may be used to interspace them

The continuous band underneath the beams ensures a better transfer of loads and is a seismic DRR.

Overlapping the elements of the reinforcement at the corners, gives a confined action

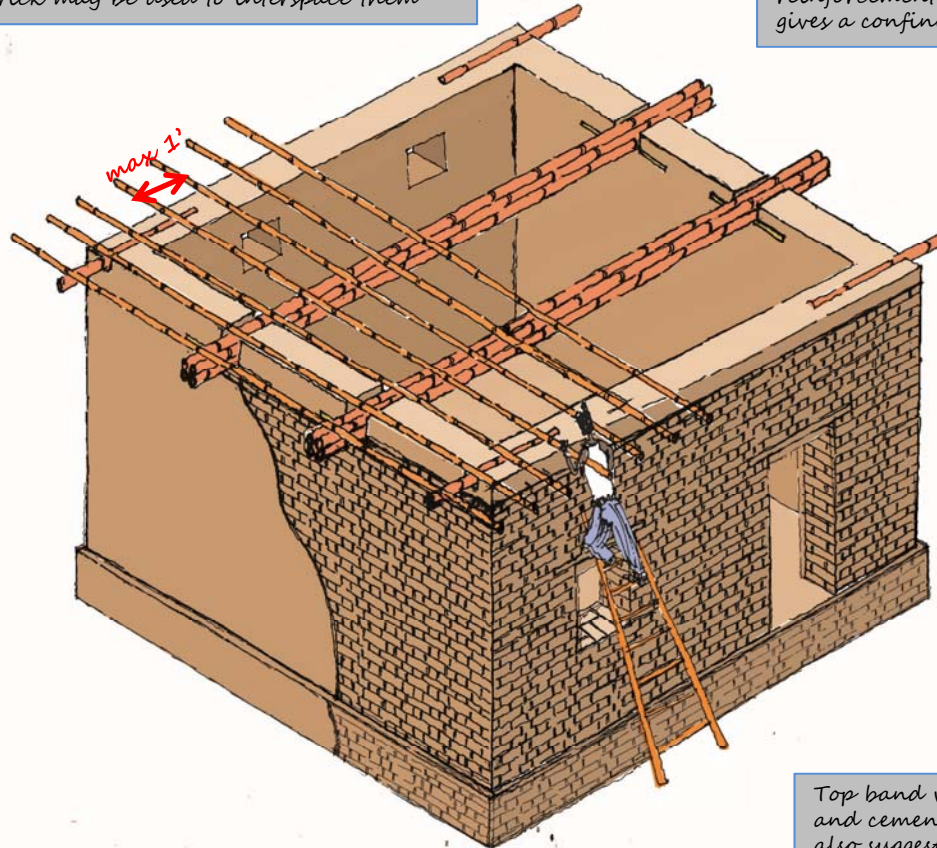

Top band with bamboos

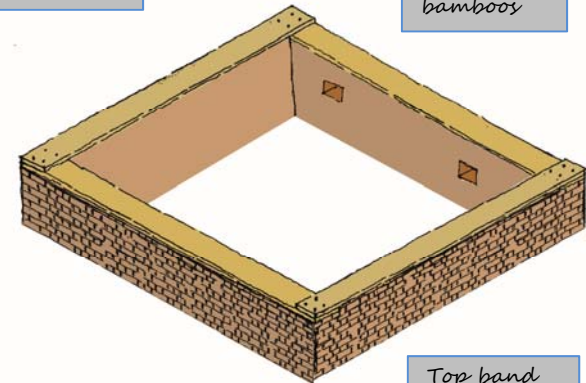

Top band with timber

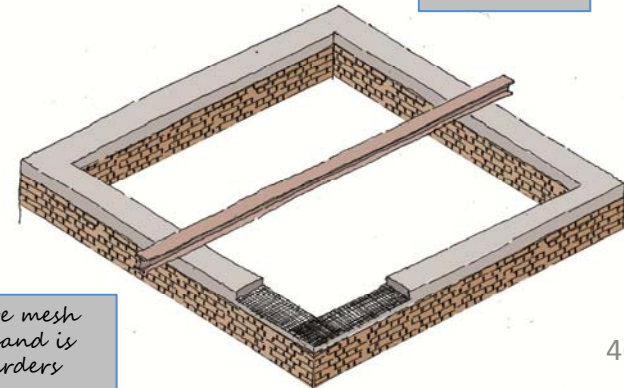

Top band with wire mesh and cement. This band is also suggested for girders

ADOBE SHELTER

Phase 5: roof

- Roofing structure and options

Although it is not recommended, another solution preferred by the beneficiaries is to use girders as main structure for the roof. The reasons why girders are preferred is because it is perceived as durable highly resistant material, it is a saved material in case of collapse, it is not affected by termites and other insects.

Reinforced concrete top/roof ring band with 3-4 steel bars #3

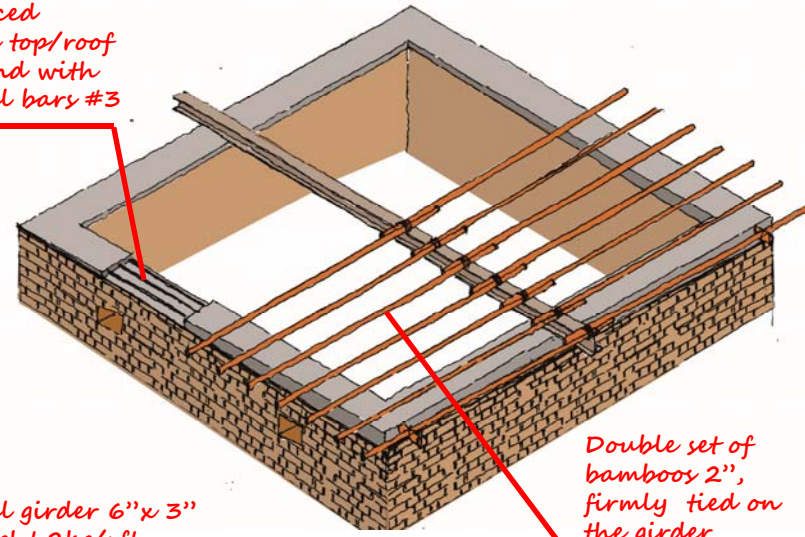

Double set of bamboos 2", firmly tied on the girder

Steel girder 6"x 3" weight 2kg/rft

Due to its higher weight it is compulsory to execute the roof ring band in reinforced concrete. A valid alternative is to build a column in fired brick with a reinforced concrete pads to bear the load of the girder. The secondary structure of purlins may be consist in a double set of bamboos, this allows also to select their right size

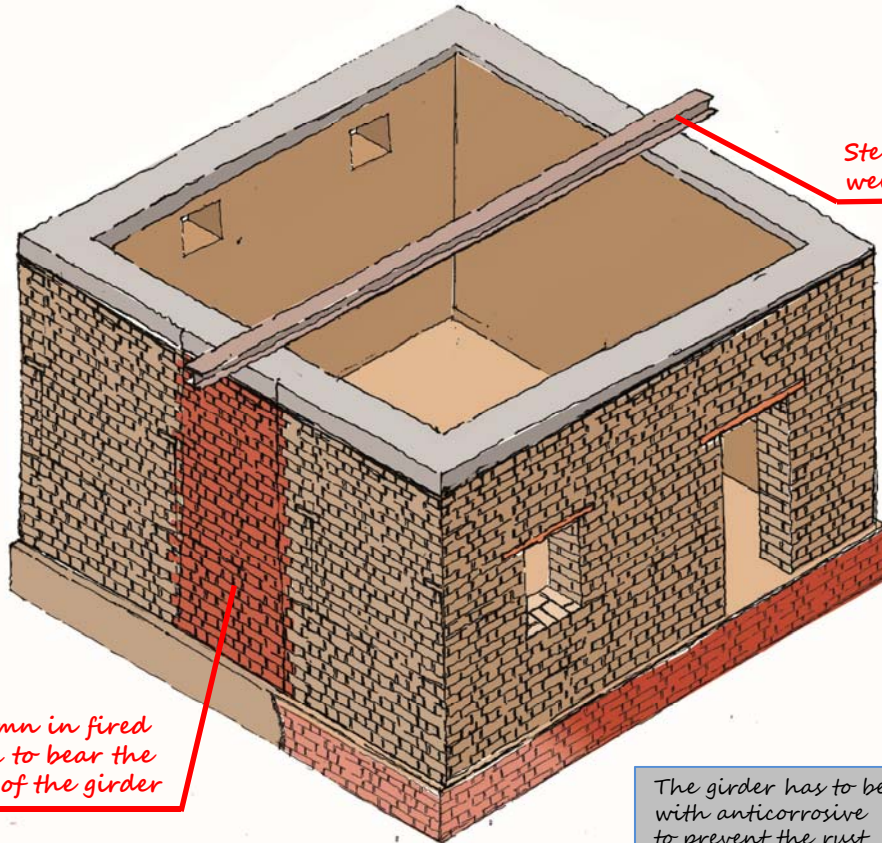

Column in fired brick to bear the load of the girder

Bearing pads as minimum requirement when girder is placed

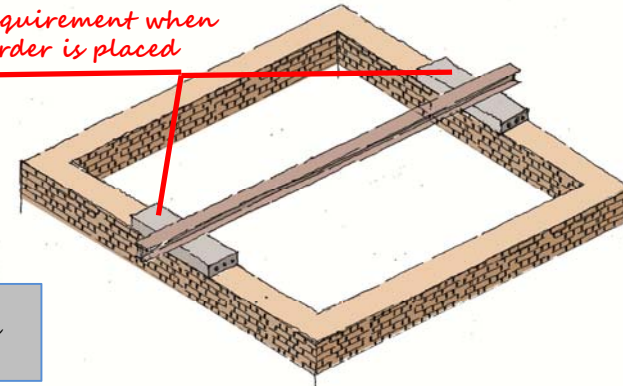

The girder has to be treat with anticorrosive solution to prevent the rust

ADOBE SHELTER

PHASES 5	ROOF
<i>Covering package Generic guidance</i>	<ul style="list-style-type: none"> -Roof topping can be made with many different materials as long as the items are lightweight, strong, durable, secured, waterproof, insulating and maintainable. -A common practice is the use of a thatch or other structural system, plastic sheeting with a mud plaster layer, protected with a final waterproofing layer. -Any material that soak water or melt should be avoided. -Lime plaster or a bitumen mixture may provide a water-resistant finish to the roof that should be reapplied prior and after annual rains.
<i>Covering package Specific guidance</i>	<ul style="list-style-type: none"> - Above the semi structural mat of straw or thatch, a polythene sheet, a layer of stabilized mud have to be applied in 2-3 coats, the thickness may be 3" maximum. Thicker mud layer may make heavy the structure. -The last coat should be a waterproof one. Lime /mud plaster may improve the water resistance. -Bitumen mixed with stabilized mud mortar is an effective treatment, it is waterproofing and fire resistant. It should be prepared by mixing (5:1) bitumen with kerosene oil and mud (1.5 kg of bitumen for 30 kg of mud), shoveled thoroughly. -Also animal dump, mixed with mud, may be a kind of waterproofing as an eco-friendly option. -In case of flat roof, the coats of plaster have to incorporate the top of the walls and the parapet, protecting the matting of plastic sheet and straw and the structure of roof, as a kind of waterproofing capping. This is a DRR that will avoid the rain water to penetrate in the connection roof/walls.

ADOBE SHELTER

PHASES 5	ROOF
<p><i>DRR waterproofing and drainage</i></p>	<ul style="list-style-type: none"> -An overhang of the roof, or eaves, of 15" minimum will prevent rainwater from running down mud or plaster of the walls and soaking into the structure and splash the plinth. This will aid the structures resilience. -For flat roof it is important a right slope to allow the rain water to wash away quickly, the stagnancy upon the roof allows the rain water soaking the top layers and penetrate in the core of walls. -Where there is a parapet is compulsory to provide 1 or 2 waterspouts, the slopes have to be arranged accordingly (minimum 1%). -The waterspouts should be minimum 2.5" and project minimum 8". -The waterspouts have to be well sealed with bitumen without any discontinuity in order to prevent water rain to penetrate in the structure of roof and walls above. -Another option may be CGI spout in "U" shape. -The use of gutters for catch rain water may be considered; obviously the slope has to be adequate in case of flat roof.
<p><i>Maintenance</i></p>	<ul style="list-style-type: none"> -Re-plaster with lime mud or bitumen mud mortar the roof at least once an year before the monsoon season or whenever necessary. -Periodic cleaning of the waterspouts. -Re-apply the film of bitumen yearly before the monsoon season -Verify the good connection between the elements of the structures (beams and purlins) -Re-treat against termite the bamboos and wooden elements once an year or whenever necessary. -Inform the owners regarding periodic treatments as termite treatment, annual re-plastering of roof and walls, periodic cleaning of the waterspouts.

ADOBE SHELTER

Phase 5: roof

- Roofing cover
- DRR measures

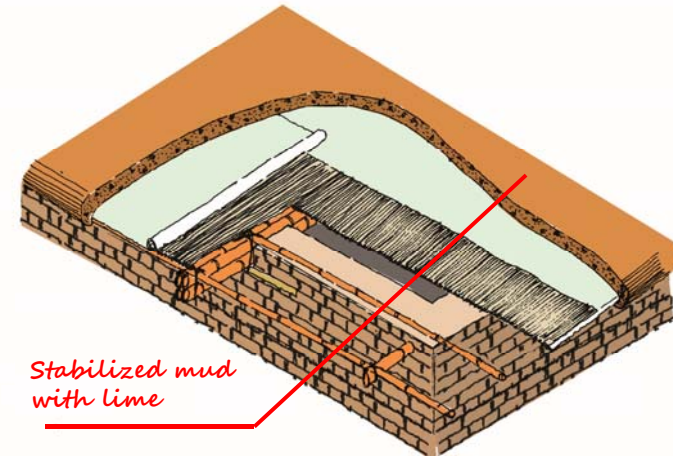
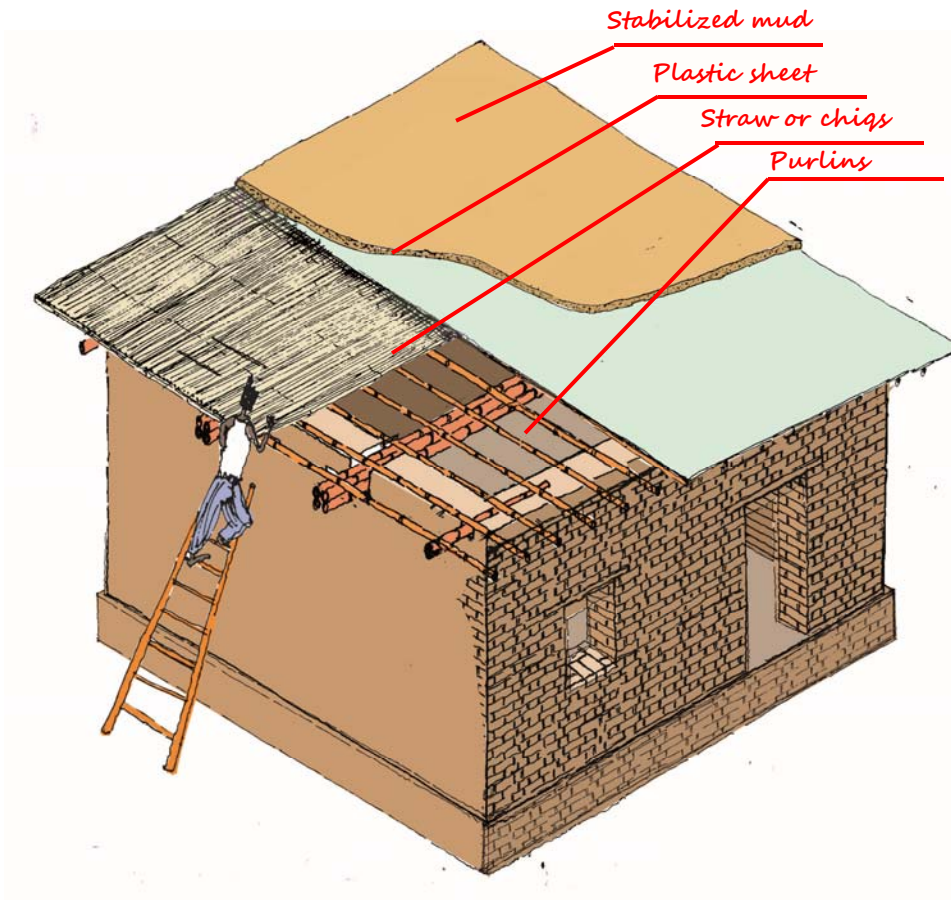

The covering package with straw, plastic sheet and 2-3 coats of mud. The last layer has to ensure waterproofing protection to the roof, thus it may be with stabilized mud with lime. The thickness should be 3" maximum.

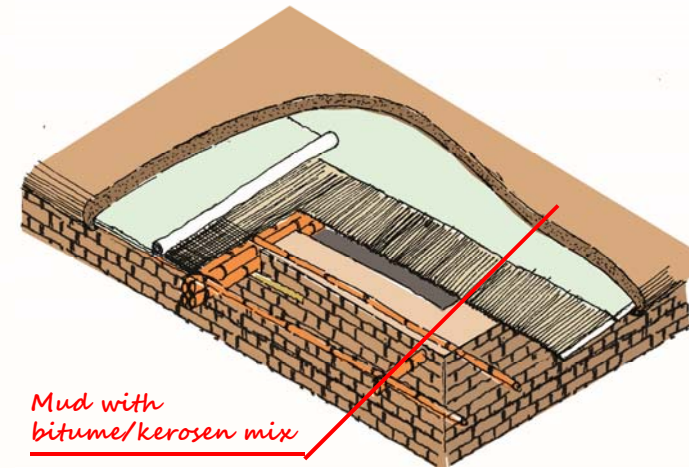

Another option for the last waterproofing layer may be by adding bitumen mixed with kerosene to the mud. The thickness may be less than 3".

ADOBE SHELTER

Maintenance :

- DRR measures
 - Waterproofing plaster
 - Roofing cover

Maintenance of the structure and DRR ensures a longer and safer life of the shelter. The main treatments to be applied periodically, i.e. yearly, are:

- Re-plastering before the raining season
- Verify and re-apply the waterproof layer of bitumen of stabilized mud till the SL
- Verify and re-apply the waterproof layer of the roof
- Control the connection of the main structure of the walls
- Re-treat against termite and insect the bamboos and other wooden elements
- Repair all the cracks that may be appear on the walls due to ground settlement and or to the dry weather
- In case of flat roof and waterspouts, clean the latest periodically

Obviously at the damages that might occur should be repaired without hesitation

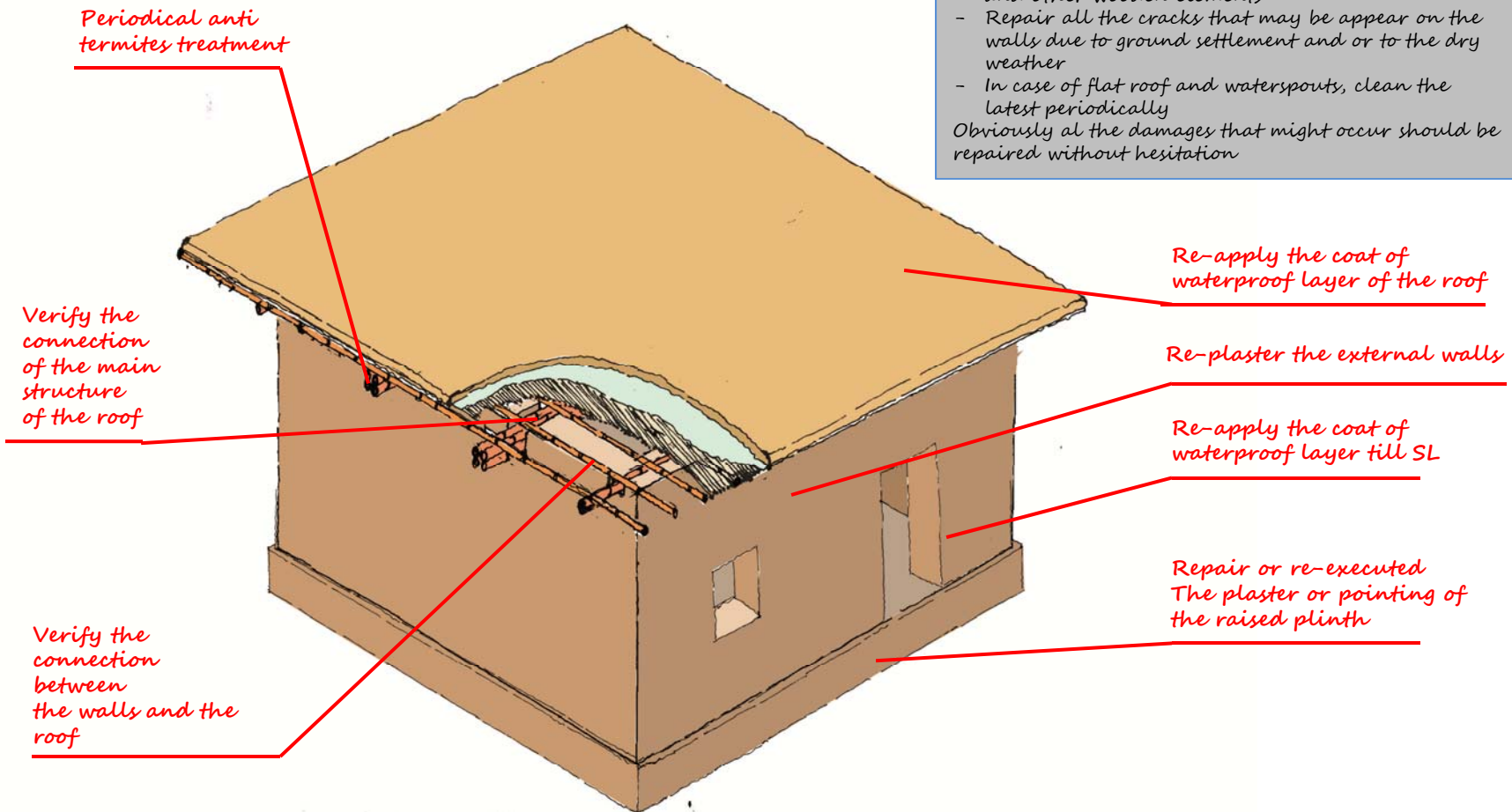

ONE ROOM SHELTER FIRED BRICK

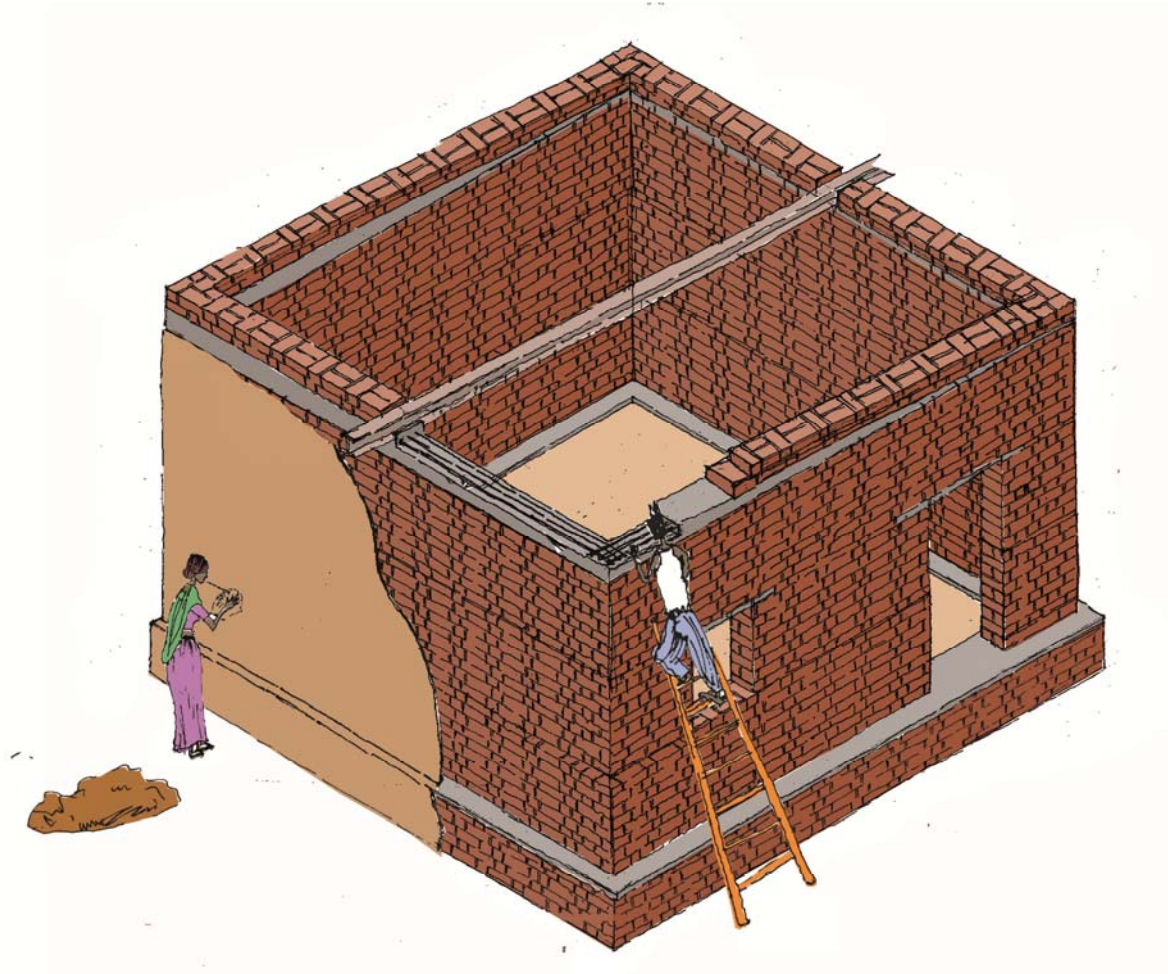

FIRED BRICK SHELTER

FIRED BRICK MASONRY SHELTER

Brick masonry houses are constructed with fired bricks and generally mud mortar with the external pointing or plastering with cement/sand plaster, in order to protect the mud mortar joints as DRR. However it is strongly suggested to use the cement/sand mortar instead of the mud one, as further DRR, since the pointing/plastering is not always executed with the consequence that the mud mortar, exposed to the weather factors, will be easily eroded.

The foundation and the raised plinth are compulsorily in fired brick masonry and cement sand mortar as DRR.

The thickness of the walls has to be 9" minimum; increasing the thickness improves the stability and DRR against earthquake.

DRR measure against floods is plastering completely the external walls to ensure protection against to rain-flash too; beside the full plastering is a way to constrain the masonry increasing therefore the resistant against the seismic action.

Plastering with cement sand the roof is also recommended, this has to be applied ensuring continuity between the roof application and the plastering of the walls.

DRR for the earthquake resistance may be a reinforcement with a vertical frame in reinforced concrete columns at the corner and opening, and reinforced bands at floor, sill, lintel and roof level. This technique is named confined brick masonry. The roof band is always suggested.

FIRED BRICK SHELTER

PHASES 1 and 2	BEARING FOUNDATIONS AND FOUNDATIONS
Generic Guidance	<ul style="list-style-type: none"> -Foundations and platforms specification, depth and height, depend on the site characteristics (soil, elevation) and super structure, materials and loads, thus their depth and width have to be designed on a case by case basis. -The excavation depth may be more than 2’ - 3’ in not compacted soils. -Generally the width of the platform should be almost one third for each side=1.6-2 times the thickness of the walls. -The foundations need to have a sealed barrier at the base to prevent that the water penetrates into the structure both from the ground (dampness) either from stagnancy. -Reinforcing the walls at ground level by adding concrete plaster /pointing layer or mud / lime may be an option. -Increasing the width of walls at the base will improve resilience against stagnant flood water and extend or prevent the time of disintegration (depending on the time of stagnancy).
Specific Guidance	<ul style="list-style-type: none"> -Excavation depth minimum 24” below undisturbed ground or compacted soil. -The wall structure or columns (reinforced masonry) should extend to the same depth of 24” to reach the solid layer and ensure stability -Minimum dimension for the foundations are 2’ wide footings founded 2’ below the Natural Surface Level (NSL).
Notes and recommendations	<ul style="list-style-type: none"> -Brick masonry has heavy load and require a concrete, stone or brick foundation to distribute the load to the ground and thus ensure stability of the walls. -Appropriate anchoring details for the foundations should be considered -The plinth can be plastered with cement/sand/lime for improve the waterproofing resistance -Burnt brick may be a better option for foundation due to their waterproofing characteristics -In order to improve the stability of the trench, a layer of cement/soil may be poured under foundations. The suggested mixture (stabilized soil) is sand(27%) soil (70 %) cement (3 %); the thickness should be 6” minimum.

FIRED BRICK SHELTER

Phase 1: excavation

- Excavation

Phase 2: foundations

- Bearing foundations
- Foundations

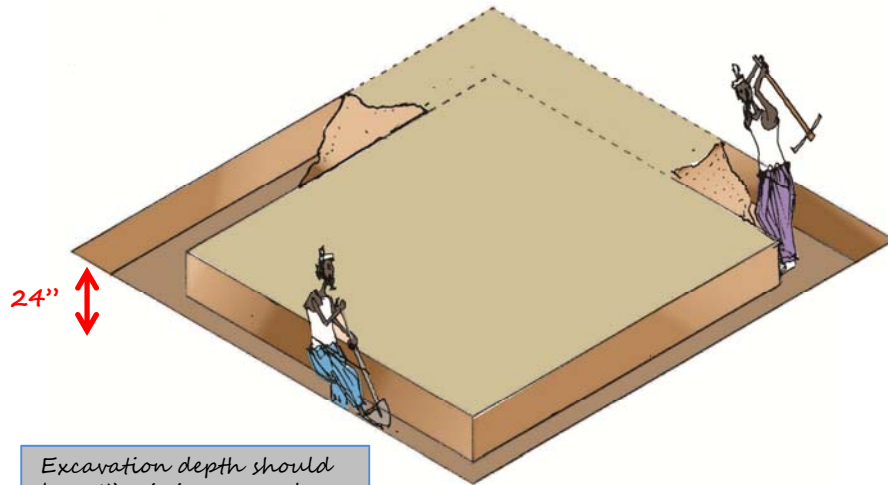

Excavation depth should be 24" minimum under compacted soil. Up to 2' - 3' when not compacted

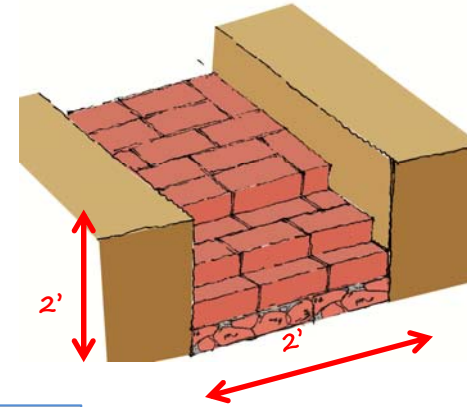

Foundation with 2' foot, founded 2' below the NSL

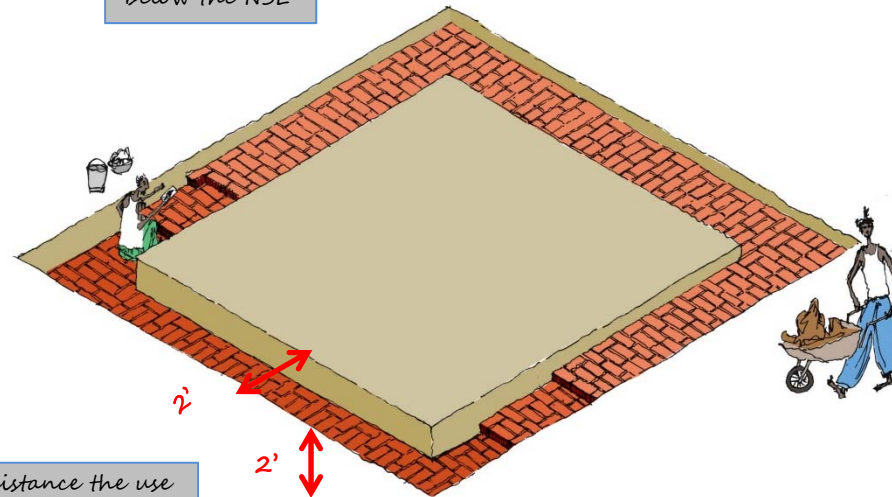

In order to give waterproofing resistance the use of cement/sand (1:4) mortar is mandatory for the foundations. Lime may be added (1:1:6)

FIRED BRICK SHELTER

PHASES 3	RAISED PLINTH FLOOR
<i>Generic Guidance</i>	<ul style="list-style-type: none"> -The floor level should be raised to at least 1'6" up to 3' above the Natural Surface Level (NSL) adopting a continuous plinth. -General recommendation is to protect furthermore the foundations below floor level by raising an earth platform 3' wide at the top and tapering to NSL over 6'. (i.e 1 in 2 slope minimum.) The top of this platform should be 6" below floor level. -A Damp Proof Course (DPC) at plinth level is compulsory in order to prevent moisture rising into the walls. A DPC is either a thin layer of concrete at plinth level with plastic on one surface or simply a strong plastic layer
<i>DRR improvements (Flood and earthquake)</i>	<ul style="list-style-type: none"> -The plinth may be with fired bricks or in concrete, cement/sand mortar has be used. -The plinth can be plastered with cement/sand/lime for improve the waterproofing - At the top the plinth a reinforce band with 2-4 bars can ensure the earthquake resistance, in case of concrete plinth it may be reinforced with 4 bars
<i>Maintenance</i>	<ul style="list-style-type: none"> -Re-plaster with lime/mud/cement mortar the raised plinth at least once yearly, before the monsoon season, and whenever necessary -In case of reinforced band: verify that the bars are not expose and corroded, paint them with red oxidant varnish

FIRED BRICK SHELTER

Phase 3: raised plinth

- Plinth
- DPC
- DRR measures

Foundations and raised plinth have to be built with cement/sand mortar (1:4).
Pointing the plinth is mandatory.

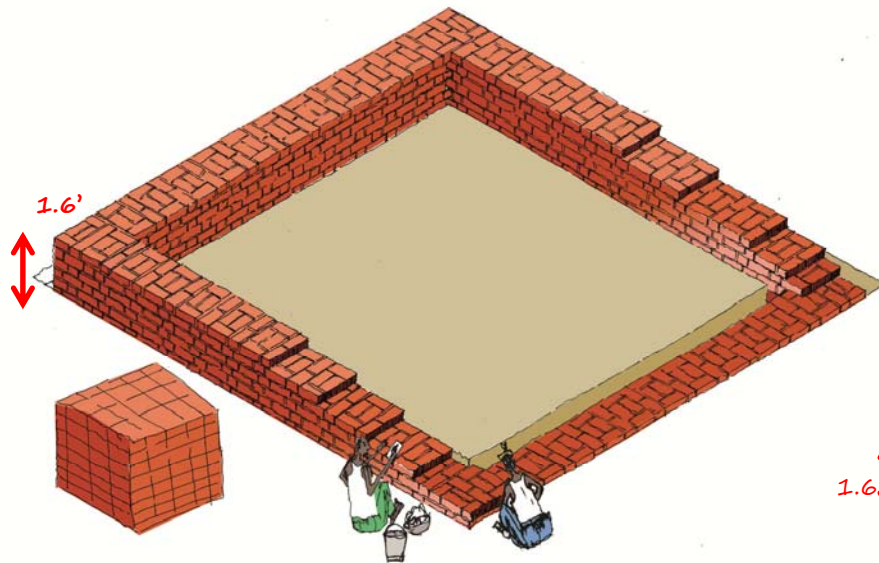

Floor level should be raised at least 1.6' up to 3' in flood affected areas

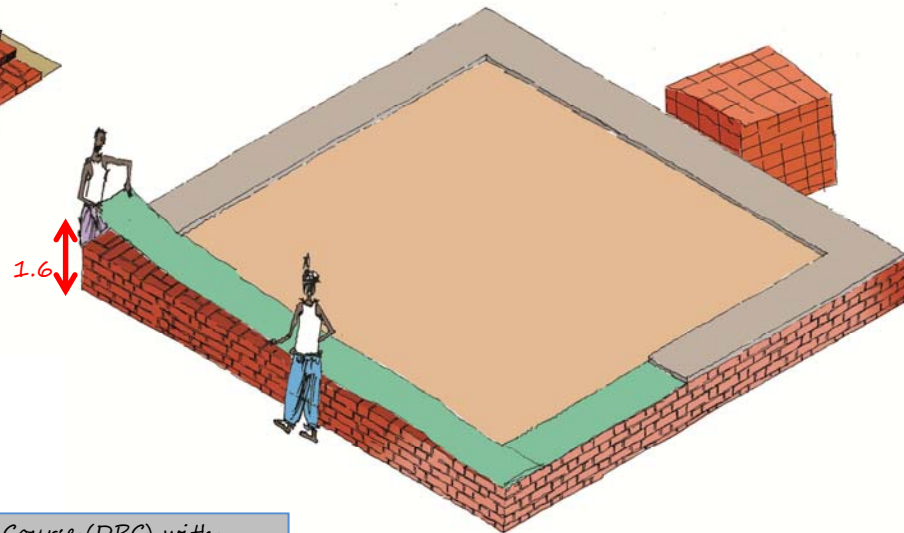

Damp Proof Course (DPC) with plastic sheet on the top of the plinth, a layer of cement improves the waterproofing characteristic

FIRED BRICK SHELTER

Phase 3: raised plinth
- DRR reinforcement

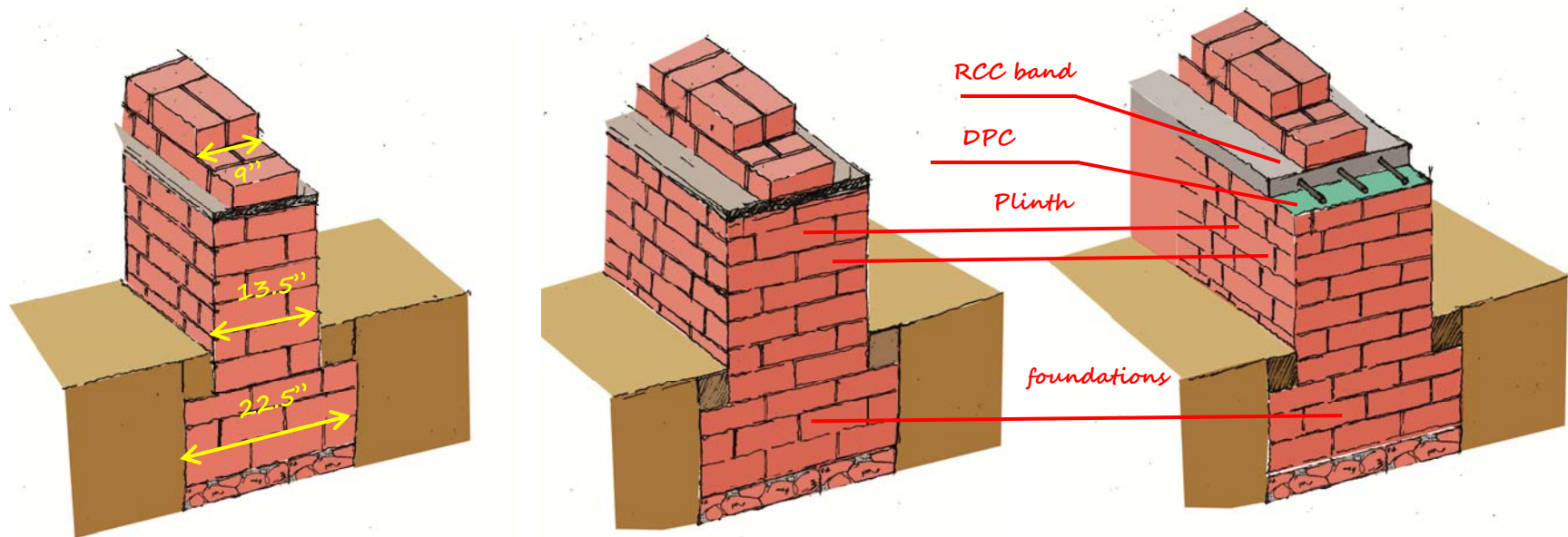

The minimum requirement for the thickness is 9", i.e. one brick length. Plinth and foundation should be enlarged respectively, 13.5" and 22.5" at least

Increasing the thickness provides stability and durability. This is suggested mainly for the foundation and plinth

DPC over the raised plinth prevent from the soil humidity. A continuous reinforced band over the plinth at floor level consists a DRR against earthquake

FIRED BRICK SHELTER

PHASES 4	SUPERSTRUCTURE
<p><i>Walls Core materials and techniques</i></p>	<ul style="list-style-type: none"> -Fired brick walls may differ in size depending on structural design. -The minimum requirement is 9", i.e. the length of a brick -Increasing the thickness provides stability, durability and waterproofing, it may be 13.5" i.e. 1.5 brick's length. -Alternate the displacement of the brick each rows to ensure the interlocking. -Construct from corners to center. -Ensure good connection from plinth to walls and interlock bricks at corners. -Reinforce long walls at center. -Avoid too wide vertical joints, and too thick bedding joints. -Hollow block walls should be reinforced using steel or similar materials. -Cement or lime and sand based mortar should be used for bonding. -Cement Mortar for General Purpose Use (but the mix can be harsh) 1 Cement: 4 Fine Sand -Cement Lime Mortar for Block and Bricklaying, plasters and Renders: 1 Cement: 1 Lime: 6 Sand -Lime Mortar for Block and Bricklaying: 1 Lime: 3 Sand
<p><i>Notes and recommendations</i></p>	<ul style="list-style-type: none"> -All junctions of the wall - at base, top and corners - need to be tied, either through interlocking or reinforcement elements like timber or steel. -Care should be taken to ensure salt in the sand is of very low levels, as salt will damage the mortar. -It is not advisable to build more the 3 shelters in line, since long walls have a negative seismic response

FIRED BRICK SHELTER

PHASES 4	SUPERSTRUCTURE
<p>DRR for earthquake resistance</p> <p>Joint and binding</p> <p>Reinforced bands</p>	<ul style="list-style-type: none"> -Thickness and good execution consist in DRR themselves. -Reinforced bands at floor level, sill level, lintel level and roof level are DRR measures against earthquakes. -The bands have to be continuous, interlocking the bars at corners. -The number of bars may be 2-4 depending on the height of the band. -The floor and top bands are suggested to be 3"-4" with 4 bars#4, while the ones at sill and lintel may be 2" with 2 bars#3. -The top band should be provided in any case as a basic DRR against earthquake. -Vertical reinforcements with steel bars collaborate to the stability and seismic resilience of the shelter. -The vertical bars have to be interlocked with the horizontal ones. -Columns in reinforced concrete, along with reinforced horizontal bands improve the seismic resistance. This kind of structure, named "CONFINED MASONRY" is the more suitable in seismic areas, but obviously it is expensive.
<p>DRR flood resistance (Plaster as protective and expendable surface)</p>	<ul style="list-style-type: none"> -The external plastering is always a good practice, since it protects the masonry from rain, wind and stagnant water, prolonging its durability. -It is suggested cement/lime/plaster at least till the sill level. -Pointing is an option from the sill level up to the roof. -Plastering the whole walls is preferable. -Plastering is mandatory for mud/lime mortar execution. -While pointing is suggested anyway in case of good quality of bricks, cement mortar and good execution of the masonry.
<p>Maintenance</p>	<ul style="list-style-type: none"> -Re-plaster with lime/mud/cement mortar the raised plinth at least once an year before the monsoon season, and whenever necessary (worn-out plaster). - Re-plaster the external walls at least once an year before the monsoon season, and whenever necessary. -In case of reinforced band: verify that the bars are not expose and corroded, paint them with red oxidant varnish.

FIRED BRICK SHELTER

Phase 4: elevation

- Sill level
- DRR measures

The external plastering is always a good practice, since it protects the masonry from rain, wind and stagnant water, prolonging its durability. Plastering is mandatory for mud/lime mortar execution

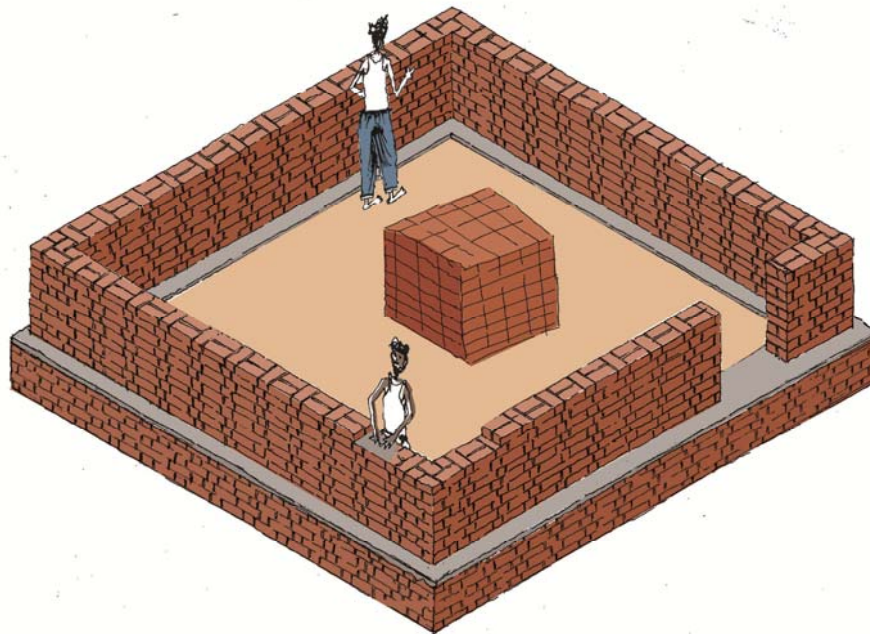

Pointing is an option, in case of good quality of bricks and cement mortar. Pointing has to be done with cement/sand mortar. Till the sill level is mandatory, up to the roof is preferable



It is suggested cement/lime/plaster at least fill the sill level. Plastering the whole walls is preferable. Adding lime may be an option. The coats should be 2.



FIRED BRICK SHELTER

PHASES 4	SUPERSTRUCTURE
<i>Opening door window</i>	<ul style="list-style-type: none"> -Openings within the wall space should not take up an area greater than 50% of the wall. -Openings should be higher than wider -Windows and doors should be kept a minimum of 2 ft from corners and from each other -The doors should open outwards for fire safety purpose.
<i>Lintels</i>	<ul style="list-style-type: none"> -Lintels have the function to bear and distribute the load of the wall above the openings -Lintels should be designed based on the load being carried overhead -Lintels should be minimum 2" thick and 6" longer than the opening for each side -For short spans timber plate or tied bamboos (2-3) may be an option, which sounds more appropriate to the mud structure -The lintel may be executed with bricks system using n.2 steels #3 and cement mortar -The pre-cast concrete lintel may be a good option
<i>Ventilation</i>	<ul style="list-style-type: none"> -Ventilation is very important mainly during the summer, that is very hot in several areas -Two windows may ensure ventilation. Alternatively one or two ventilators, executed on the opposite side of the window (generally on the back wall) may ensure a good ventilation -The dimensions depend on the size of the shelter, it may be one of 2' x 1' or two 1'x1' -In some areas, where the summer is very hot, it may be suggested to increase the height of the shelter to improve the internal ventilation (in this case the entire structure of the shelter has to be re-calculated)

FIRED BRICK SHELTER

Phase 4: elevation

- Lintel level
- Details and options of lintels

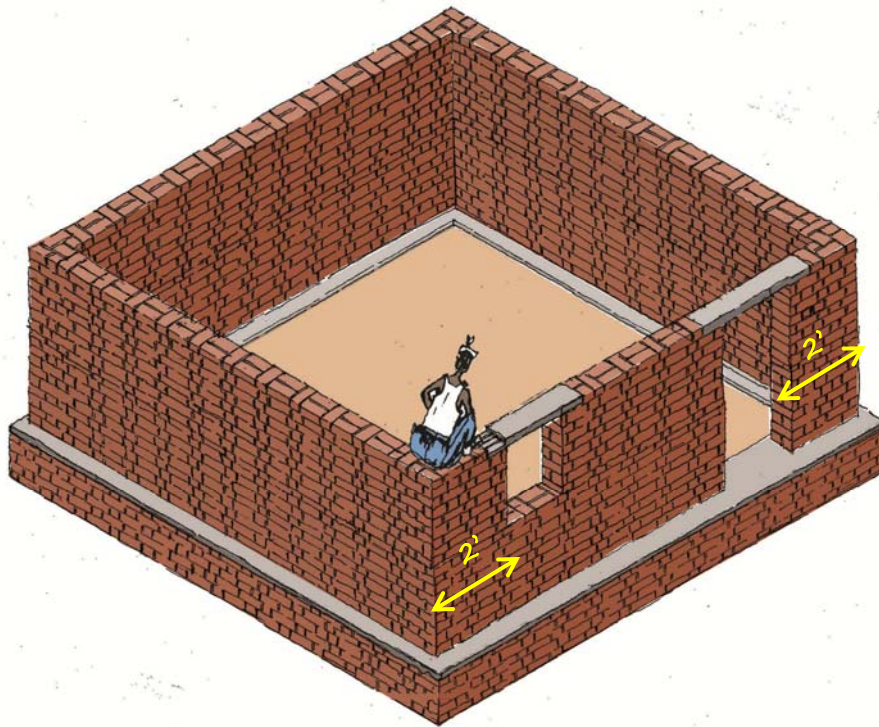

Openings should be 2' from the corners, always higher than wider. Never be over than the 50% of the wall

Lintels should be 6" longer than the opening for each side; the thickness should be 2" at least. Wider opening may need longer and thicker lintel

Lintels may be executed with 2 T irons and bricks in between with cement mortar

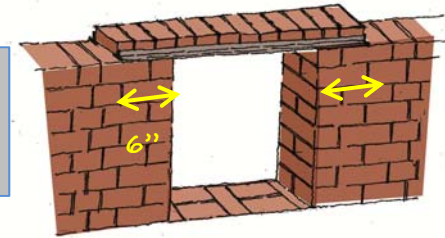

Timber is another option for short span

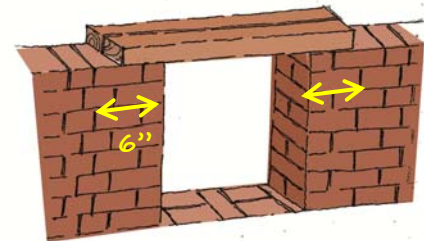

Lintel may be executed with 3 steel bars # 2 and cement

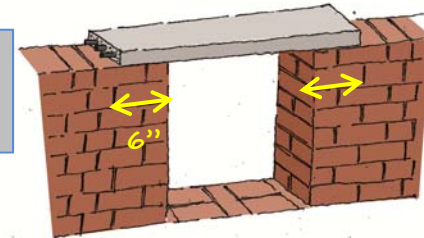

A pre-cast concrete lintel is a good option

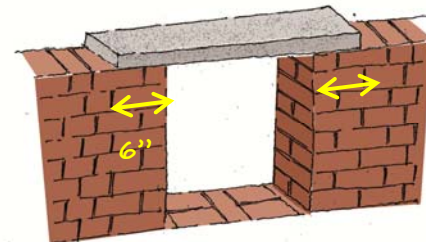

FIRED BRICK SHELTER

Phase 4: elevation

- DRR: reinforcing bands

Continuous RCC bands at FL, SL and LL, with steel bars #3 and cement

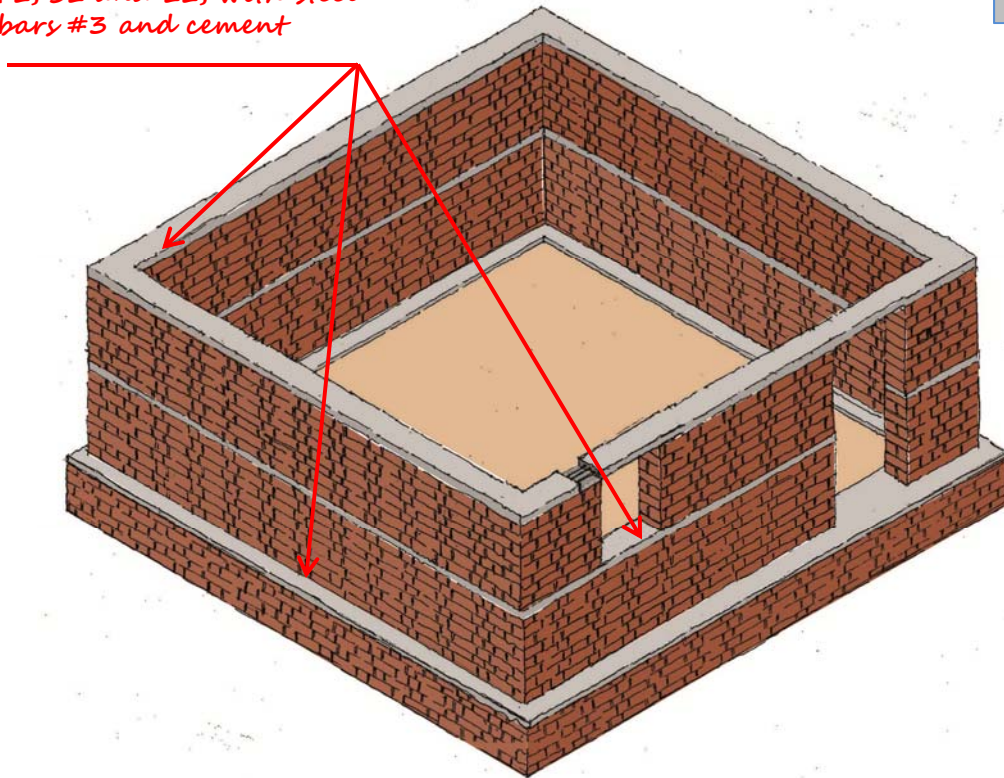

To strengthen the structure reinforced bands may be executed at different levels i.e. floor level (FL) sill level (SL) and lintel level (LL) the top ring band at roof level (RL) should be always executed. They consist DRR themselves. They should be RCC bands executed with steel bar # 3 for the SL and LL and # 4 for the FL and RL. The action of the bands is to confine the masonry improving the resilience against the horizontal forces as earthquakes

Reinforcement of the corner with "L" insert with 2 steel bars # 3 of 2'

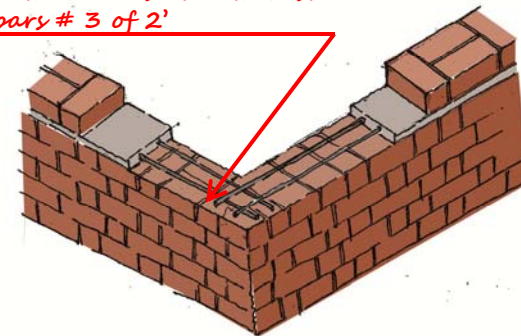

Other option less expensive is to reinforce the corner only. The reinforcement should be executed every 2,5', with 2 steel bar # 3 and concrete. The function of corner reinforcements is to avoid the separation of the walls due to horizontal forces as earthquakes or increased loads

FIRED BRICK SHELTER

Phase 4: elevation

- Roof level
- Continuous roof band

The top ring band should be executed always because its confining action is DRR against earthquakes. It has to be executed as RCC with 3 - 4 steel bars # 4 and pouring concrete (cement - gravel - sand 1:2:4). The bars have to be overlapped and jointed at the corners. However the minimum requirement consists in inserting concrete bearing pads underneath the girders at least.

Option with 2 girder,
better for T-irons purlin

Option with 1 girder,
good for bamboo purlin

Continuous ring band

Minimum requirement as DRR
against flood, plastering at least
till the sill level (SL)

Placement of the steel
bars. Overlap and joint
the bars at the corners

There are several options for the roof structure. Girders are mostly suggested, with top ring band or at least bearing pads. Accordingly the dimension of the shelter and in case of secondary structure with T-irons and tiles, which have heavier loads, the number of girders has to be two

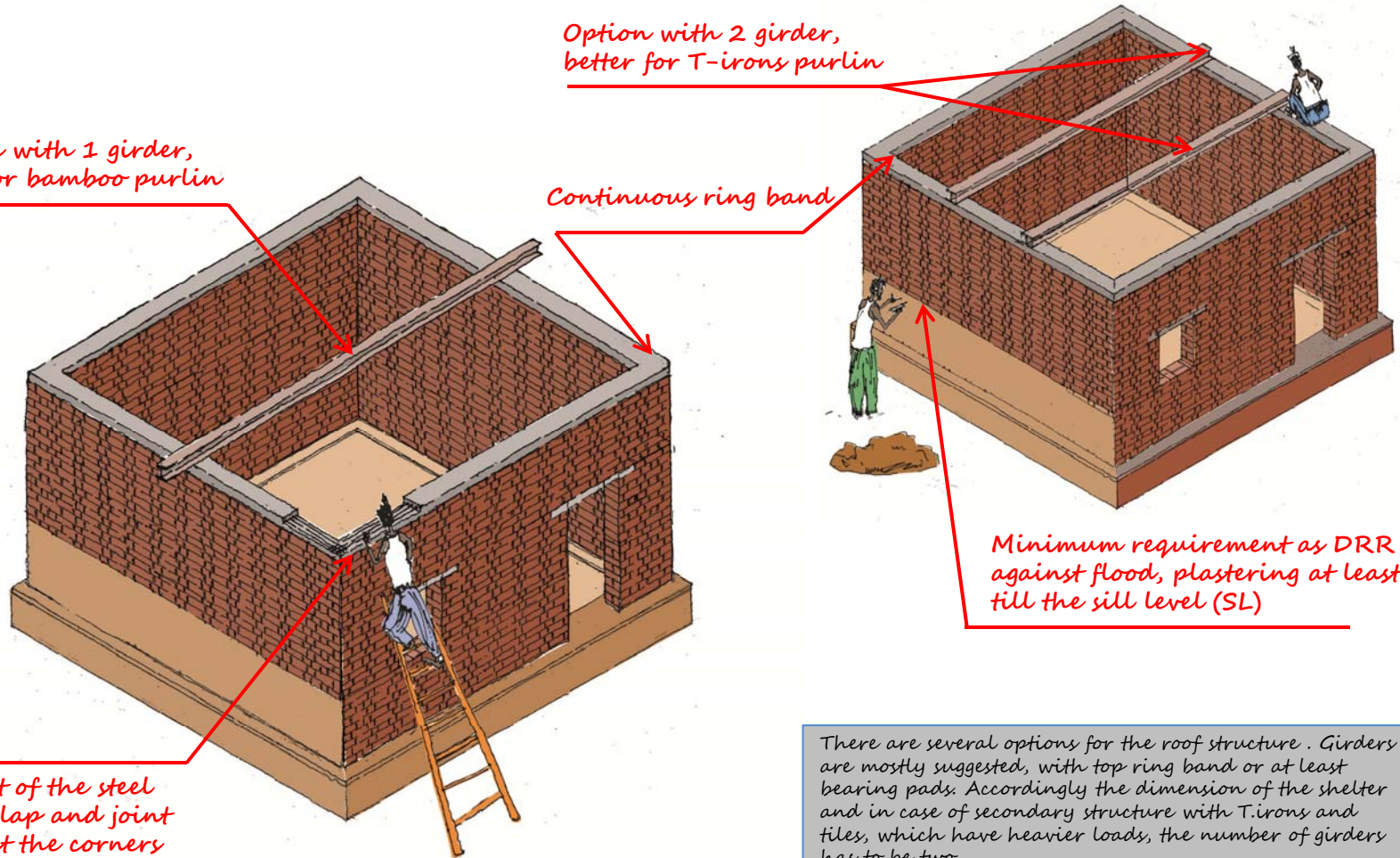

FIRED BRICK SHELTER

PHASES 5	ROOF
<i>Generic guidance</i>	<ul style="list-style-type: none">-Roof design should allow for live and dead loads. Live loads are applied loads such as rain, wind, snow or usage for grain or livestock. Dead loads are those including the makeup of the roof structure such as beams, straw, mud, cement etc.-A bamboo or other lightweight roof can be used for all construction methodologies, while steel girder roof or similar heavy roof requires a strong bearing structure, therefore it is only suitable for fired brick, concrete block, engineered steel frame shelters.-A thick mud layer will add a lot of load to the roof and may cause severe, damaging strain to the roof structure and loadbearing walls.-Timber elements may in some cases be larger loads than steel or other alternatives.-Bamboo and timber are susceptible to termites. Adequate treatment should be provided to timber and bamboo materials.-Timber, bamboo or straw roofs are not suitable for indoor cooking or heating fires.-A conical or four-sided pitched roof is preferable in areas where wind loads are a consideration, particularly cyclone vulnerable areas.-Gable ends or flat surfaces may be more stress by resisting to the wind force-The pitch of a roof will vary based on the wind conditions in the area, however a maximum pitch is advised of 30° for simple pitched roofs.-A mono-pitched roof may have a pitch of up to 10° to allow adequate drainage of rainwater.-In the flat roof a minimum slope should be 3/8" per foot.

FIRED BRICK SHELTER

PHASES 5	ROOF
<p>Main structure</p>	<ul style="list-style-type: none"> -This structure is supposed to be more resistant, thus the solution of the bamboos beam is not suitable, neither the less is not forbidden. -Timbers of adequate size and steel girders are suitable options. -The girder "I" beam size should depends on the number (1 or 2), loads of the roof and thickness of walls. -the minimum size is 6" x 3" with a weight of 2/2.2 Kg/rft. Suggested sizes are also 4"x6" or 4"x8", 5.5"x2.5" with heavier loads. -Bearing plate, or pad, has to be inserted underneath the girder in order to distribute its load. -A steel plate may be 12"x8"x0.5", a concrete tile or wooden board may be on option. -Anti-oxide treatment is suggested for the iron/steel elements. -The secondary structure of purlins may made by assembling well sized bamboos. -The distance between bamboos should be not more than 1' (1 brick), their length has to be enough to overlap the thickness of walls -Above the bamboos a mat of chick, straw, thatch and plastic sheet is generally used. -Straw and plastic sheet have to be incorporate in the top of the walls by the final plastering. -Bamboos, timber and straw should be treated against termites. -An alternative to the "I" girder may be a concrete precast beam. -An alternative to the bamboos and straw are the "T" beams (T-iron) and tiles of cement or burned clay.
<p>Note and recommendations for earthquake resistance</p>	<ul style="list-style-type: none"> -All loadbearing elements of the roof structure, columns, beams and joists have to be not placed above door or window openings. Any openings provide weaknesses in the walls, because reduce the portion of bearing walls, thus placing the loadbearing elements right above the openings may cause failure in the walls with cracks and even collapse of the portion interested. -Any elements of the roof structure should be tied to each other. All joists or beams in the roof structure need to be individually tied to purlins. The roof must also be securely tied to the wall structure. Well fastening ensure a good resistance to the strong wind and is a kind of DRR against earthquake. -Roofs have different load distribution arrangements, as the concentration of loads underneath the beams, thus in order to distribute equally the roof loads a top plate/band or ring beam should be provided at the top of the walls. It should be continuous encircling the walls, this provides a way of fastening the walls together at the top to prevent pushing outward forces of the roof and in case of horizontal seismic forces. -In case of pitched roof with two gables placing plates/bands at the top of the wall (without gables) distribute the loads and constrains the pushing forces of the rafters. -It is suggested to assemble trusses instead of rafters, since the horizontal bottom chord ties the inclined top chords constraining their pushing outward forces.

FIRED BRICK SHELTER

Phase 5: roof

- Roof level
- Main structure and options

Option with 2 girder, and T-irons purlins

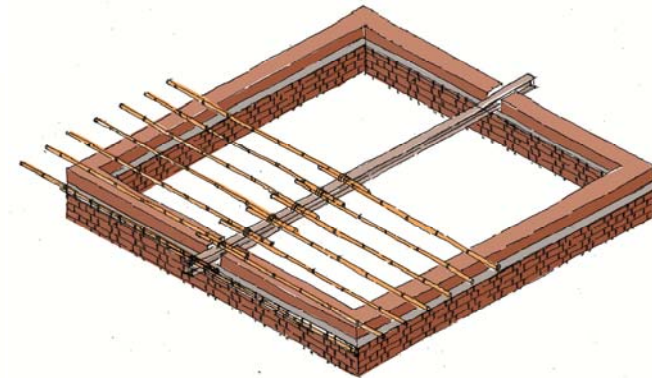
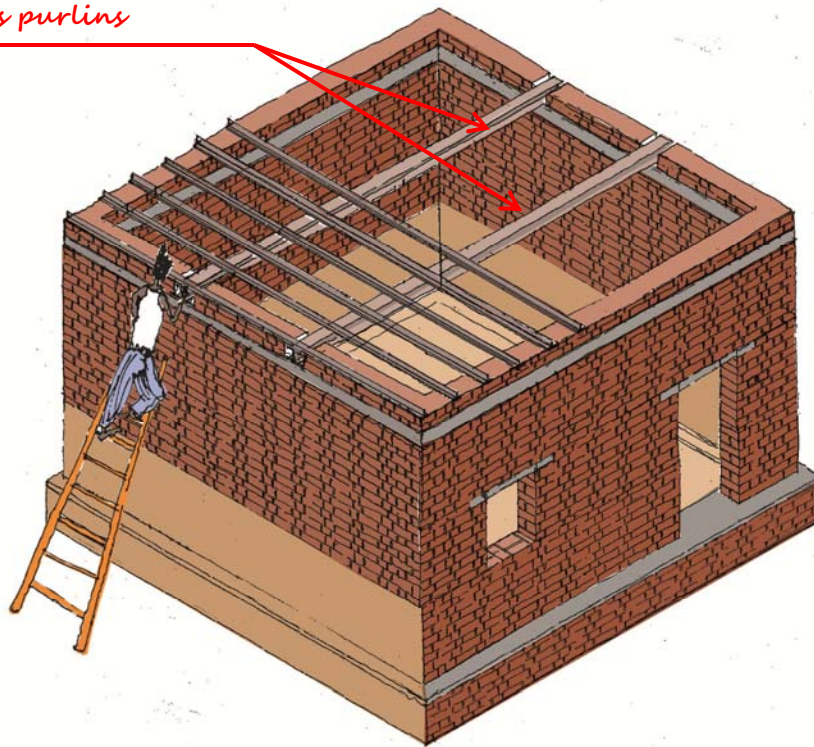

Option with 1 girder, good for bamboo purlins, with eaves

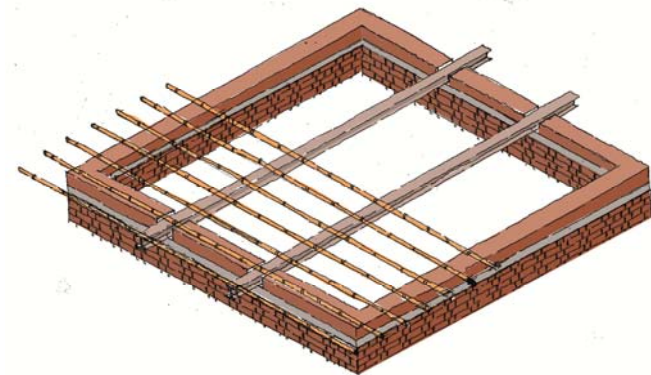

Option with 2 girder, good for bamboo purlins, without eaves

There are several options for the roof structure. Girders are mostly suggested, with top ring band or at least bearing pads. Accordingly the dimension of the shelter (and the financial resources) the girders may be also two. They have to be two in case of secondary structure with T-irons and tiles, for the heavier loads.

FIRED BRICK SHELTER

PHASES 5	ROOF
<i>Covering package Generic guidance</i>	<ul style="list-style-type: none"> -Roof topping can be made with many different materials as long as the items are lightweight, strong, durable, secured, waterproof, insulating and maintainable. -A common practice is the use of a thatch or other structural system, plastic sheeting with a mud plaster layer, protected with a final waterproofing layer. -Any material that soak water or melt should be avoided. -Lime plaster or a bitumen mixture may provide a water-resistant finish to the roof that should be reapplied prior and after annual rains.
<i>Covering package Specific guidance</i>	<ul style="list-style-type: none"> - Above the semi structural mat of straw or thatch, a polythene sheet, a layer of stabilized mud have to be applied in 2-3 coats, the thickness may be 3” maximum. Thicker mud layer may make heavy the structure. -The last coat should be a waterproof one. Lime /mud plaster may improve the water resistance. -Bitumen mixed with stabilized mud mortar is an effective treatment, it is waterproofing and fire resistant. It should be prepared by mixing (5:1) bitumen with kerosene oil and mud (1.5 kg of bitumen for 30 kg of mud), shoveled thoroughly. -Also animal dump, mixed with mud, may be a kind of waterproofing as an eco-friendly option. -In case of flat roof, the coats of plaster have to incorporate the top of the walls and the parapet, protecting the matting of plastic sheet and straw and the structure of roof, as a kind of waterproofing capping. This is a DRR that will avoid the rain water to penetrate in the connection roof/walls.

FIRED BRICK SHELTER

PHASES 5	ROOF
<p>DRR <i>waterproofing and drainage</i></p>	<ul style="list-style-type: none"> -An overhang of the roof, or eaves, of 15" minimum will prevent rainwater from running down mud or plaster of the walls and soaking into the structure and splash the plinth. This will aid the structures resilience. -For flat roof it is important a right slope to allow the rain water to wash away quickly, the stagnancy upon the roof allows the rain water soaking the top layers and penetrate in the core of walls. -Where there is a parapet is compulsory to provide 1 or 2 waterspouts, the slopes have to be arranged accordingly (minimum 1%). -The waterspouts should be minimum 2.5" and project minimum 8". -The waterspouts have to be well sealed with bitumen without any discontinuity in order to prevent water rain to penetrate in the structure of roof and walls above. -Another option may be CGI spout in "U" shape. -The use of gutters for catch rain water may be considered; obviously the slope has to be adequate in case of flat roof.
<p>Maintanance</p>	<ul style="list-style-type: none"> -Re-plaster with lime mud or bitumen mud mortar the roof at least once an year before the monsoon season or whenever necessary. -Periodic cleaning of the waterspouts. -Re-apply the film of bitumen yearly before the monsoon season -Verify the good connection between the elements of the structures (beams and purlins) -Re-treat against termite the bamboos and wooden elements once an year or whenever necessary. -Inform the owners regarding periodic treatments as termite treatment, annual re-plastering of roof and walls, periodic cleaning of the waterspouts.

FIRED BRICK SHELTER

Phase 5: roof

- Roofing cover
- DRR measures

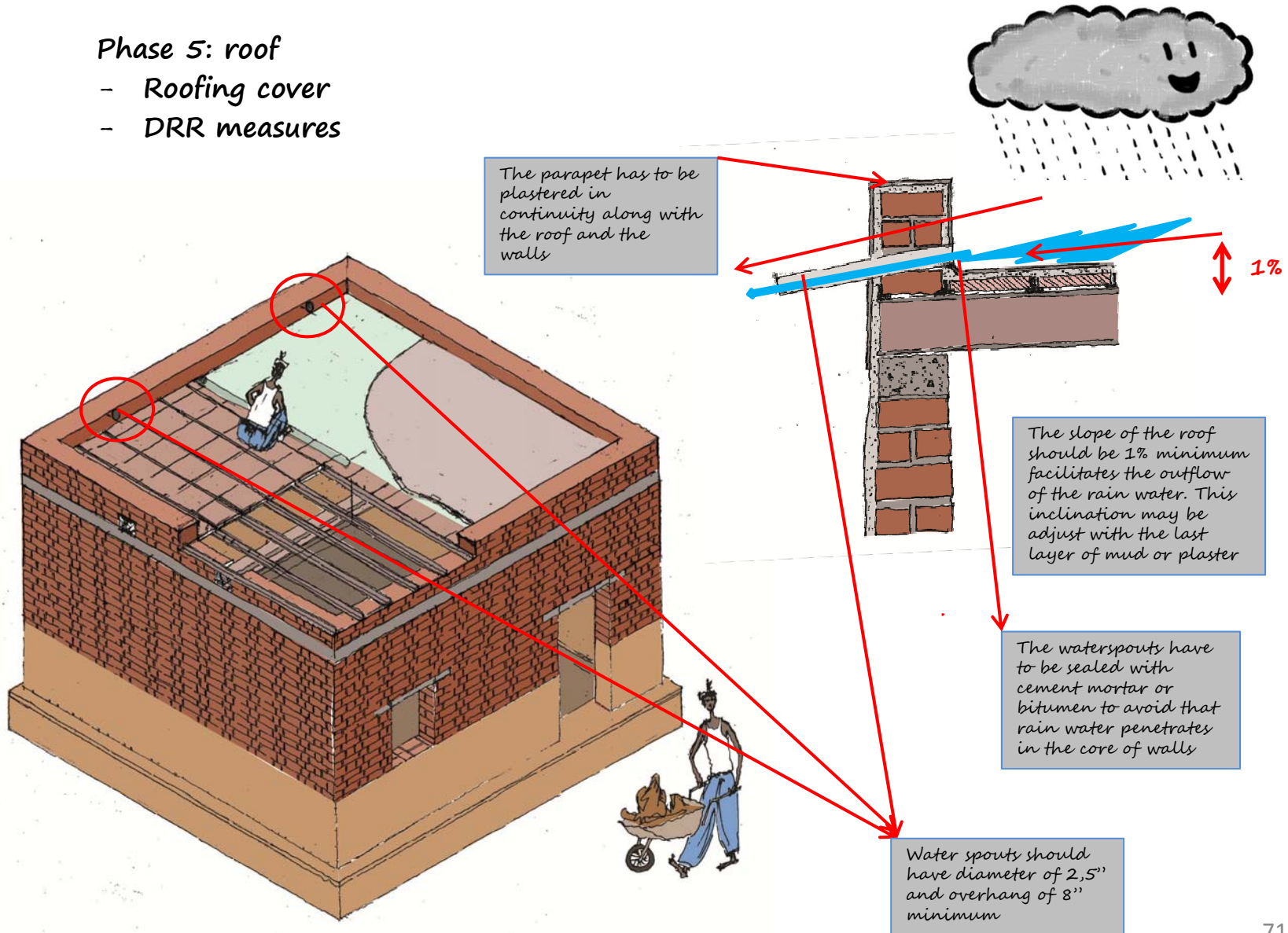

FIRED BRICK SHELTER

Phase 5: roof

- Roofing cover
- DRR measures

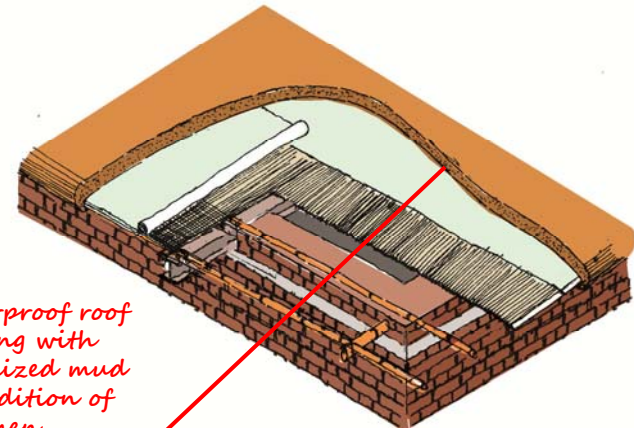
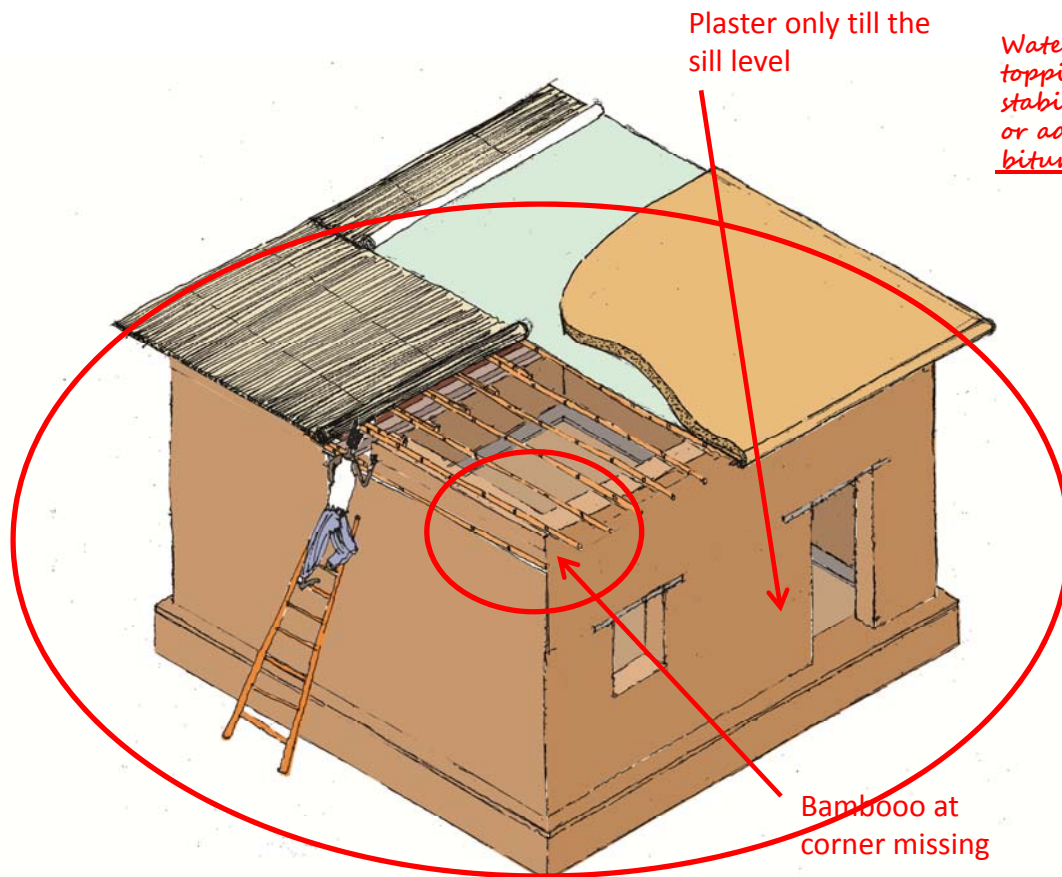

Waterproof roof topping with stabilized mud or addition of bitumen

The covering package with straw, plastic sheet and 2-3 coats of stabilized mud with lime or bitumen/kerosen mix. The last layer has to ensure waterproofing protection to the roof, thus it may be with stabilized mud with lime. The thickness should be 3" maximum

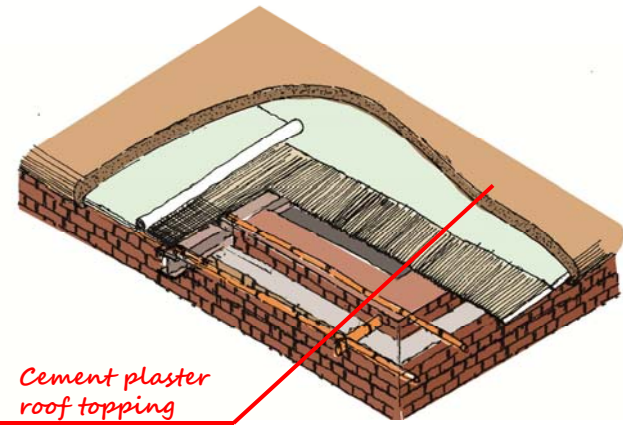

Cement plaster roof topping

the last waterproofing layer may be cement/sand plaster. The thickness may be less than 3". It is important to apply the plaster with continuity

FIRED BRICK SHELTER

Maintenance :

- DRR
- Waterproofing plaster
- Roofing cover

AAAA. Change the sketch with the complete shelter

Maintenance of the structure and DRR ensure a longer and safer life of the shelter. The main treatments to be applied periodically, i.e. yearly, are:

- Re-plastering before the raining season
- Verify and re-apply the waterproof layer of bitumen of stabilized mud till the SL
- Verify and reply the waterproof layer of the roof
- Control the connection of the main structure of the walls
- Re-treat against termite and insect the bamboos and other wooden elements
- Repair all the cracks that may be appear on the walls due to ground settlement and or to the dry weather
- In case of flat roof and waterspouts, clean the latest periodically

Obviously at the damages that might occur should be repaired without hesitation

