



# GUIDE TO DOMINICA'S HOUSING STANDARDS





# Introduction

## Ministry of Planning, Economic Development and Investment

---

The Ministry of Planning, Economic Development and Investment is pleased to present the Guide to **Dominica's Housing Standards**. The Guide was developed in collaboration with the United Nations Development Program, Engineers Without Borders, the World Bank, the Physical Planning Division and Ministry of Housing. Our gratitude is extended to these partners.

The Post Disaster Needs Assessment conducted with the assistance of Development Partner in the aftermath of Hurricane Maria which struck Dominica on September 18, 2017 indicated that damage in the housing sector was extensive with damage to approximately 90 percent of the housing stock. Of the 31,348 homes comprising the Dominican housing stock, a total of approximately 4,700 houses (15%) were identified as destroyed, approximately 23,500 of homes, (75%) were estimated to have incurred different levels of partial damage, and 3,135 (10%) were considered as not affected by the event. Total damage to the housing sector is estimated at EC\$956 million (US\$354 million). This included the replacement cost of destroyed houses, repair cost of partially damaged houses, and the replacement cost of household goods destroyed. Losses were estimated at EC\$77 million (US\$28.5 million) and include expected loss of rental income, the cost of demolition, rubble removal, and shelter expenses.

It became necessary to revisit the building regulations (Building Code and Building Guidelines) and the Physical Planning Act of 2002 with the aim to update/amend so as to adequately and effectively respond to the need for recovery in the Housing Sector. The result of the exercise was the updating of the Building Code to be submitted for approval, followed by proposed amendments to the Act. The development of the Guide to Dominica's Housing Standards, therefore, is presented as a first response mechanism to address the need for climate resilient residential housing construction.

The Guide is a derivative from the Dominica Building Code and the Dominica Building Guidelines, intended to serve as an easy reference tool for all stakeholders involved in roofing repairs/reconstruction, and partial or complete reconstruction of residential buildings post Hurricane Maria. The guidelines provided aim to meet the minimum standards in accordance with Build Back Better principles catering to housing structures which are resilient to weather and seismic events.

As we seek to advance our efforts to restore to better than pre-Maria conditions, it is critically important that home owner, builders and contractors observe and adhere to these standards.

Thanking you

**Permanent Secretary**  
**Ministry of Planning, Economic Development and Investment**

# GUIDE TO DOMINICA'S HOUSING STANDARDS

## PREFACE

---

The publication of this booklet forms the Housing Standards for the Commonwealth of Dominica.

All construction plans must be submitted to the Physical Planning Division for approval.

This project was developed by the Ministry of Planning, Economic Development and Investment, with funding from the Government of the People's Republic of China and the assistance of UNDP and Engineers Without Borders.

This booklet was informed by the Informal Housing Retrofit and Safe Construction Pilot Project administered in Dominica by the National Development Foundation of Dominica (NDFD), with technical input from Safe Shelter Initiative (SSI) with credit to USAID, OECS, OAS and CRDC.

# GUIDE TO DOMINICA'S HOUSING STANDARDS

## HURRICANES

A hurricane is a rotating low pressure tropical system with high power circular winds exceeding 74 mph and is usually accompanied by heavy rains and thunder storms.

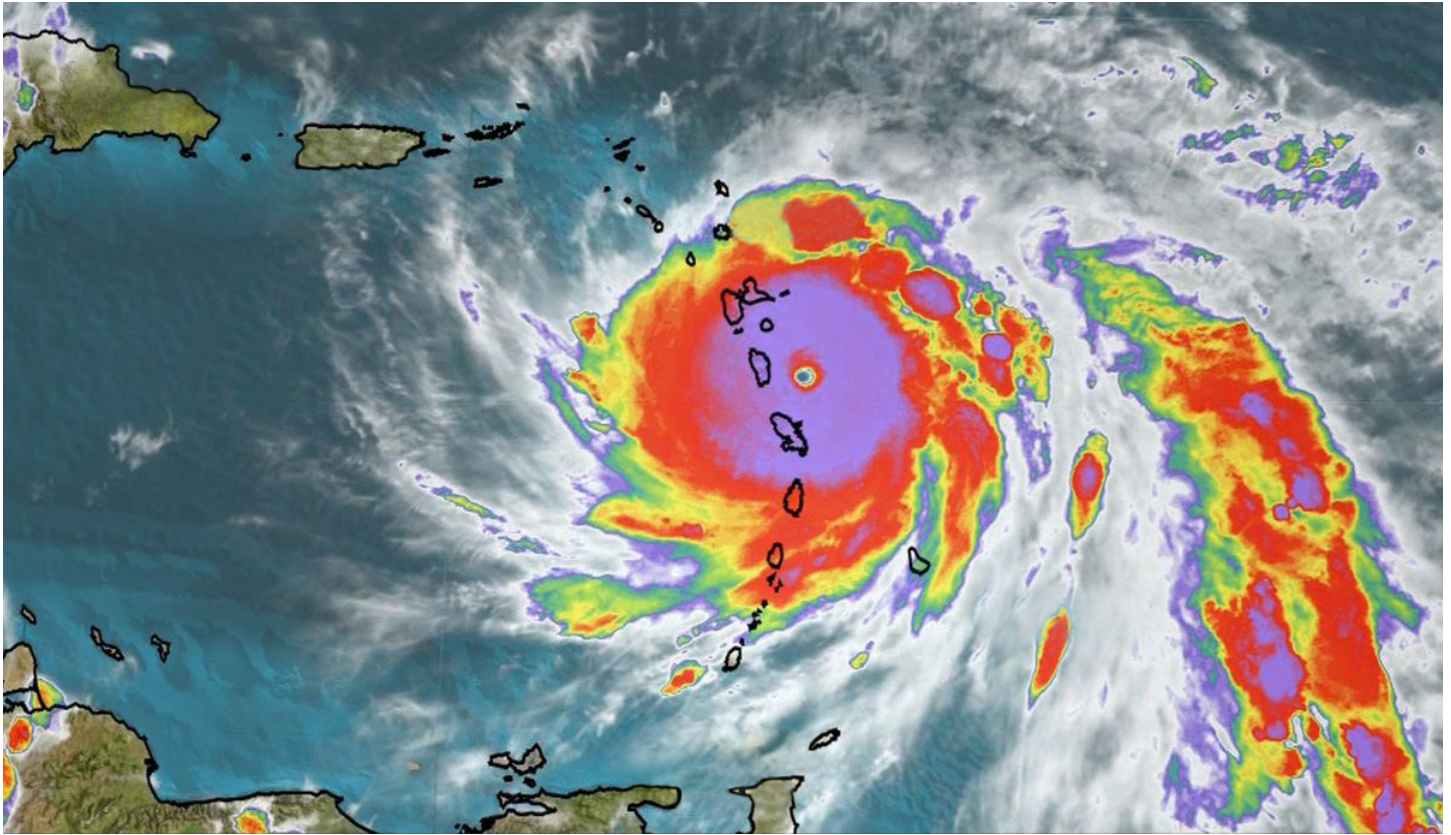

The eye is the calmest of the hurricane.

The strongest winds are located at the eye wall, which encloses the eye.

After the eye passes, the wind will come again from a different direction.



# GUIDE TO DOMINICA'S HOUSING STANDARDS

## HURRICANES

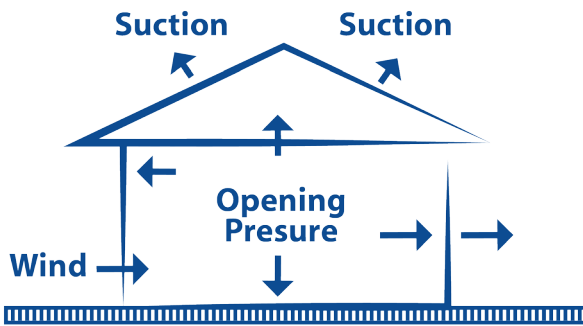

Wind generating an opening on the windward side during a hurricane will increase the pressure of the internal surfaces. This pressure, in combination with external suction, may be sufficient to cause the roof to blow off and the walls to explode.

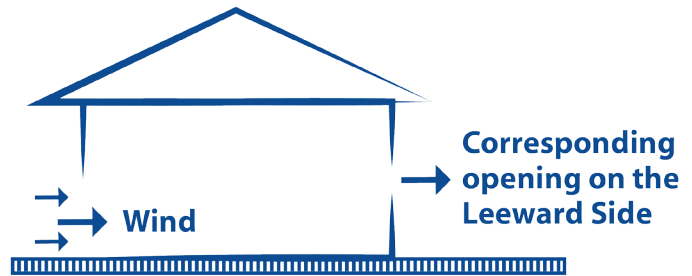

The internal pressure that builds up as a result may be relieved by providing a corresponding opening on the leeward side.

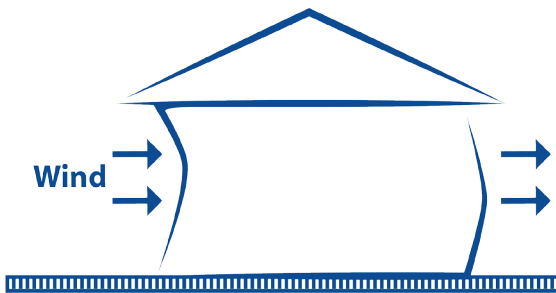

Windward face of the building collapses under pressure of windforce.

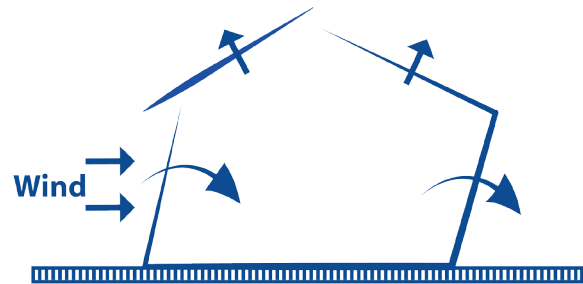

**RACKING**  
Collapse starts at the roof with the building leaning in the direction of wind flow.

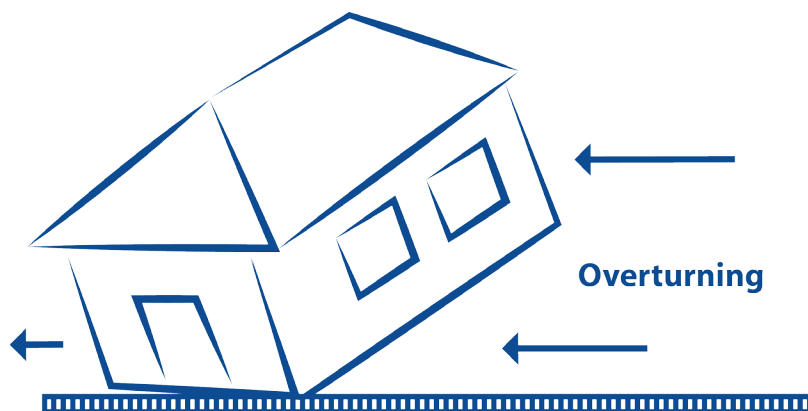

Caused by poor connection to the foundation.

# GUIDE TO DOMINICA'S HOUSING STANDARDS

## HURRICANES

THE ENORMOUSLY POWERFUL WINDS OF THE HURRICANE CAN:

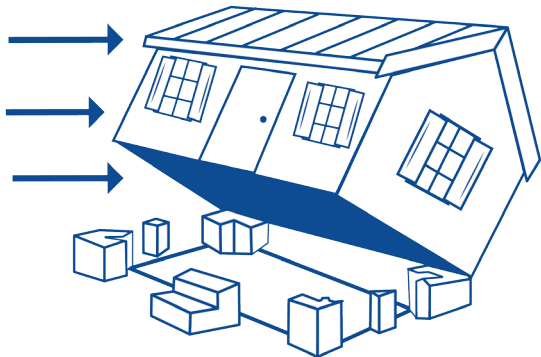

1. Blow it off its footing



2. Take off the roof

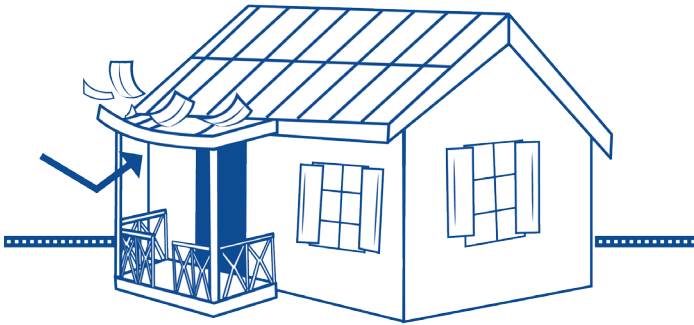

3. Remove verandah and garage roofs.



4. Cause flooding because of heavy rains.

# GUIDE TO DOMINICA'S HOUSING STANDARDS

## SITING

WHEN CHOOSING A SITE FOR YOUR HOUSE, CONSIDER THE FOLLOWING:



A house is best built on a flat, firm site provided it is well drained.

If your lot is on a slope, don't place the house like this unless it is properly anchored. Columns need to be infilled with shear walls and beams.



The wind and water can dislodge the house.



Cut and fill is a common means of levelling a house site. Avoid building on the fill. Foundation should be on solid ground. This house is safer, cut into the side of the hill.



# GUIDE TO DOMINICA'S HOUSING STANDARDS

## DESIGN OF THE HOUSE

THE CHOICE OF HOUSE DESIGN IS ALSO VERY IMPORTANT IN MAKING IT DISASTER RESISTANT.

### Plan Shapes of Buildings



### DESIRABLE PLANS



### LONG, UNDESIRABLE PLANS

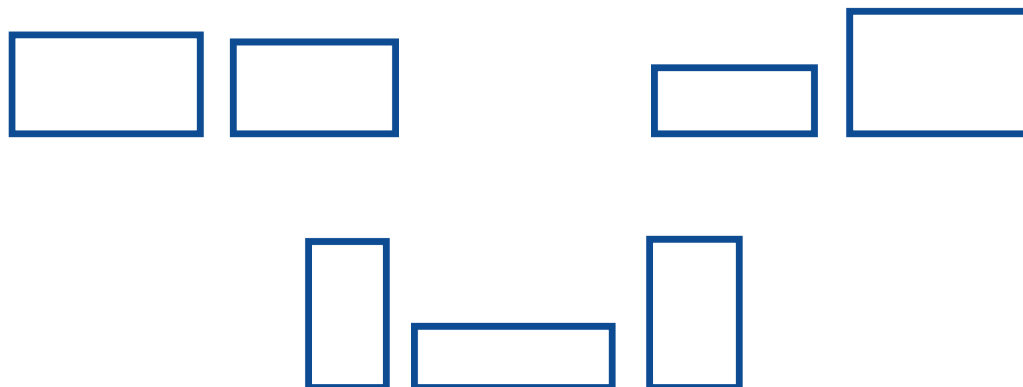

### USE OF SEPARATION TO IMPROVE RESISTANCE

The success with which a building survives an earthquake is significantly affected by its shape in plan. Most buildings with a simple rectangular shape, with no projections, perform well under earthquake conditions; provided the construction is adequate. Long narrow buildings should be avoided. Long buildings should be divided into separate blocks with adequate separation (6" for 1 story building).

# GUIDE TO DOMINICA'S HOUSING STANDARDS

## FOUNDATIONS

The foundation is the part of the house which transfers the weight of the building to the ground. It is essential to construct a suitable foundation for a house, as the stability of the building depends primarily on its foundation.

### THE MAIN TYPES OF FOUNDATIONS ARE:

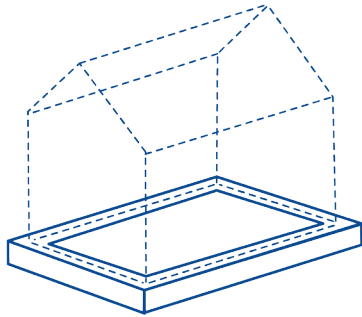

#### Slab or Raft Foundation

- Used on soft soils.
- Spreads the weight over a wider area

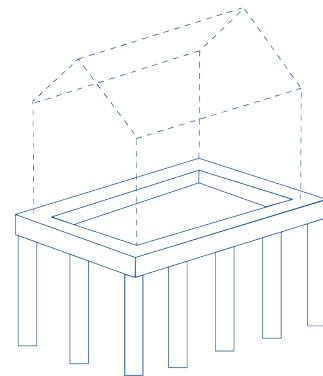

#### Pile Foundation

- Are deep foundations for heavy buildings.
- Not often used in small buildings.

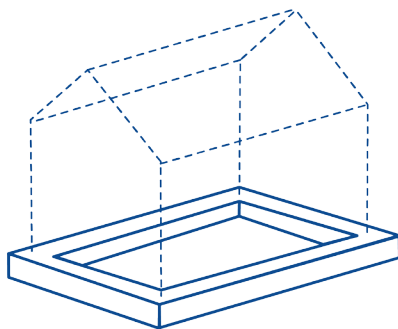

#### Strip Foundation

- Used for areas where the soil varies.
- Most common
- Supports a wall

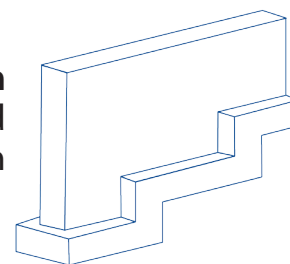

#### Stepped Foundation

- Used on sloping ground
- Is a form of strip foundation

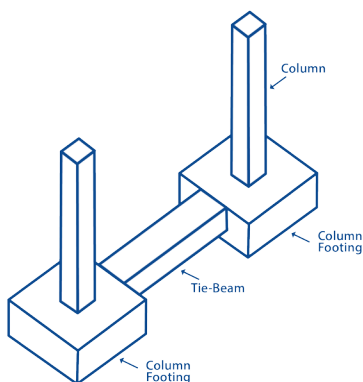

#### Pad Foundation

- Used on firm soil
- Used for columns and poles

**NOTE: Tie beams between pads are required**

# GUIDE TO DOMINICA'S HOUSING STANDARDS

## FOUNDATIONS

### FOUNDATION CONSTRUCTION TECHNIQUES

*The functions of the foundations are:*

- To securely anchor the house to the ground to prevent wind forces from lifting the entire building or blowing it over.
- To transmit the building loads to the ground. Foundations should be securely connected to the rest of the structure and located not less than 3 feet into the ground on firm strata.

The foundation for the block wall construction is usually a continuous rectangular reinforced concrete strip footing.

The blockwalls which are then built up from this footing contain vertical reinforcement which is anchored into the footing.

Block walls shall be constructed using running bond instead of stacking bond.

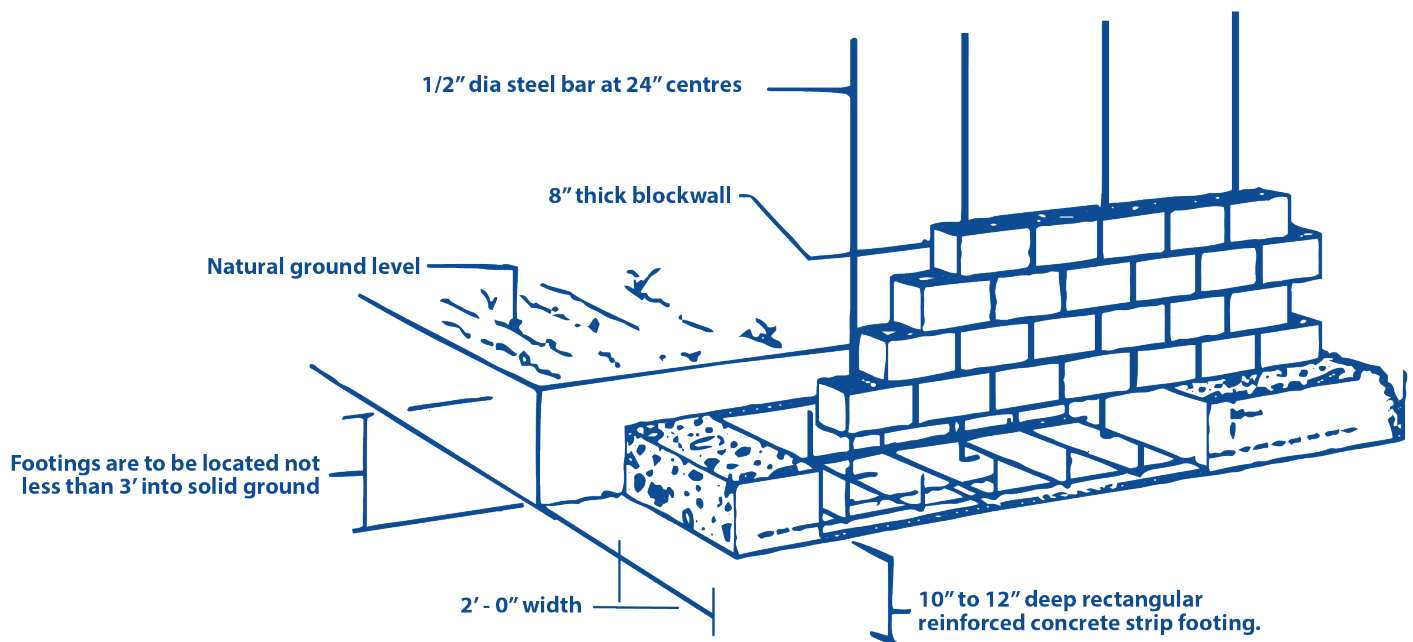

# GUIDE TO DOMINICA'S HOUSING STANDARDS

## FOUNDATIONS

### REINFORCEMENT

#### TYPICAL CROSS SECTION OF BLOCK WALL FOUNDATION

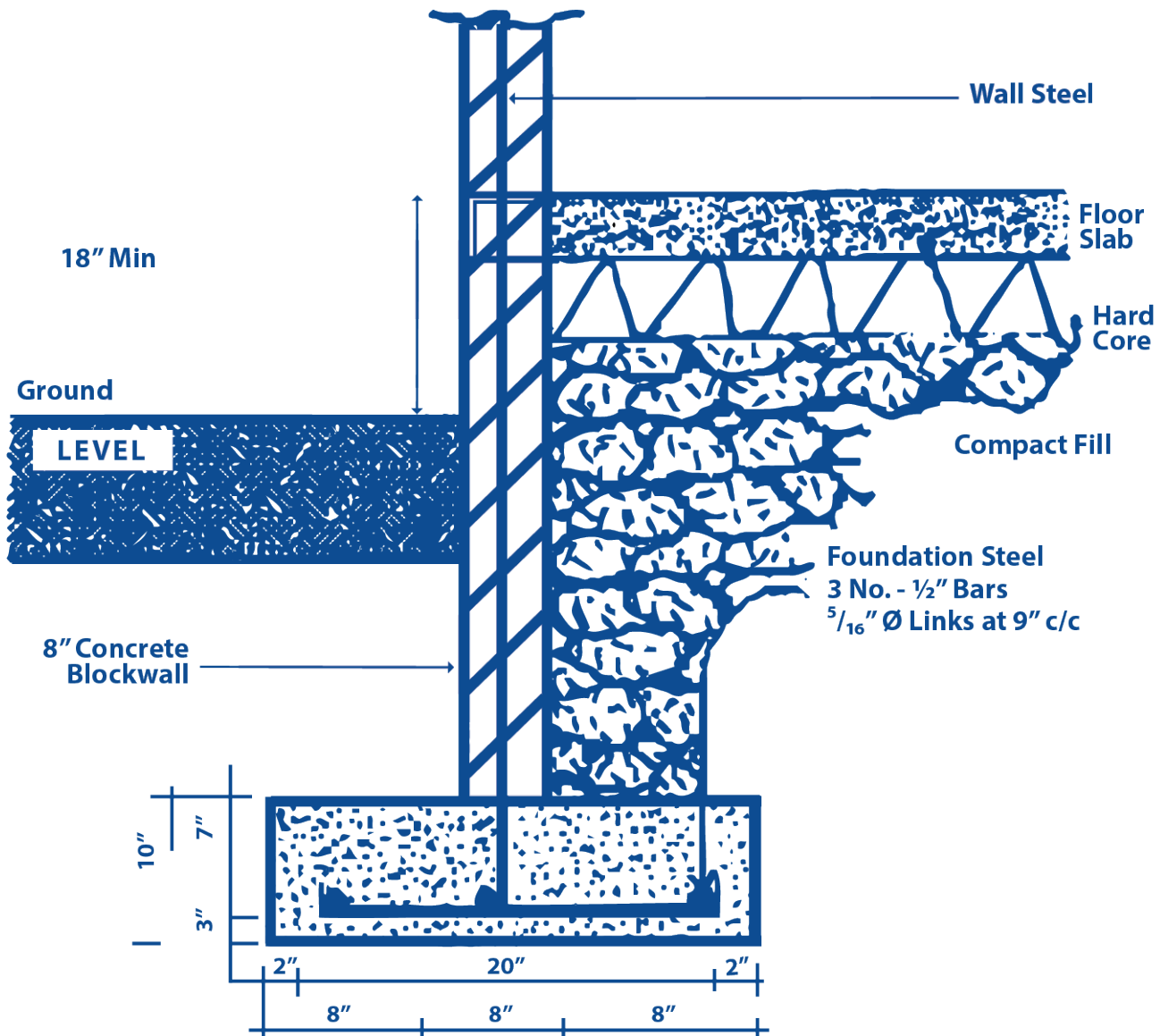

#### REINFORCEMENT TO STRIPFOOTING

# GUIDE TO DOMINICA'S HOUSING STANDARDS

## THE WALLS

### WALLS

#### CONCRETE BLOCK WALLS

- Starter bars coming out of the foundation will tie the wall to the same.
- Lay blocks so that those starter bars come out through block pockets. The foundation page calls out vertical  $\frac{1}{2}$ " bars at 32", we are also requiring that reinforcement is continuous from foundation to roof, so this is consistent. This will provide adequate resistance to hurricanes and earthquakes. As more courses are laid one must add more lengths of steel which will overlap at least 18" with starter bars.
- These lengths of steel should go right up through to the top of wall.
- Pockets of block containing reinforcement are to be filled with concrete every 3 courses;
- As each course of blocks is laid, it must be set into a 1:3 mortar bed place on the last course. Mortar is also required on the sides of the blocks to form the vertical joints. Mortar joints should be  $\frac{1}{2}$ " to  $\frac{5}{8}$ " wide.
- Horizontal reinforcement consisting of two  $\frac{3}{8}$ " diameter bars, or Brickforce, should be laid every third course. This increases the resistance of the wall to hurricane force winds and to earthquakes.
- Vertical bars are required at all junctions, windows and door openings.

#### CONCRETE BLOCK WALL

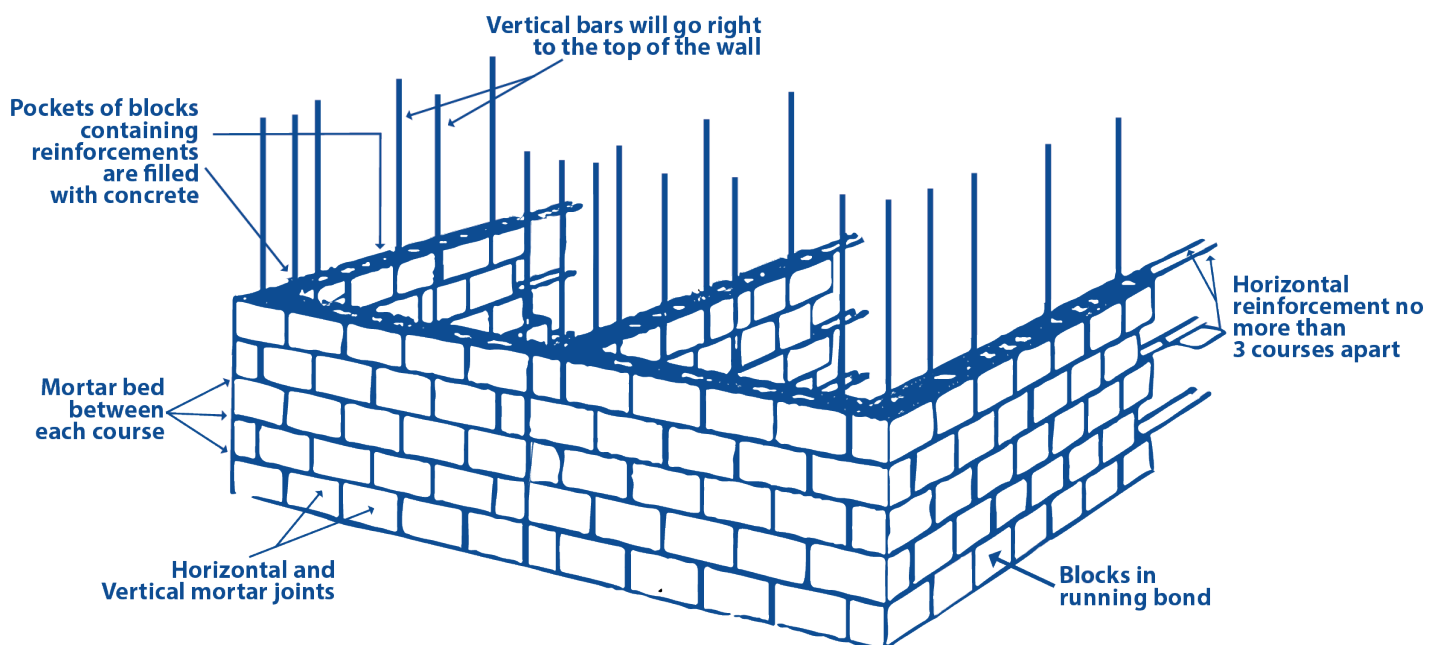

# GUIDE TO DOMINICA'S HOUSING STANDARDS

## THE WALLS

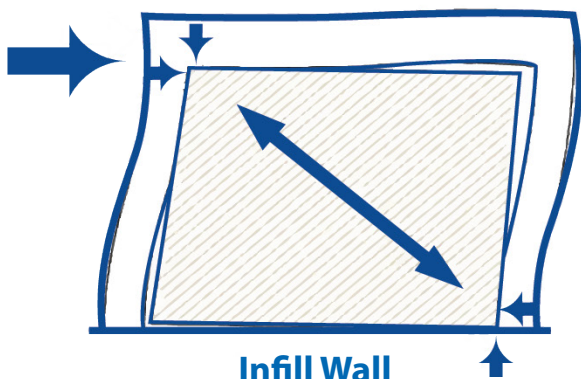
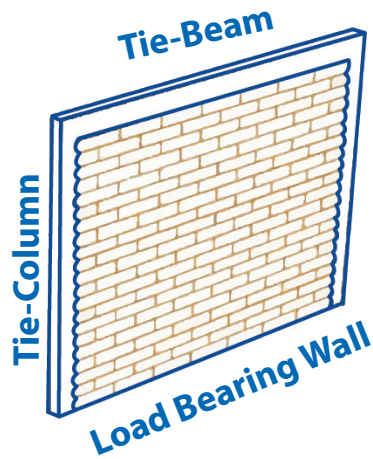
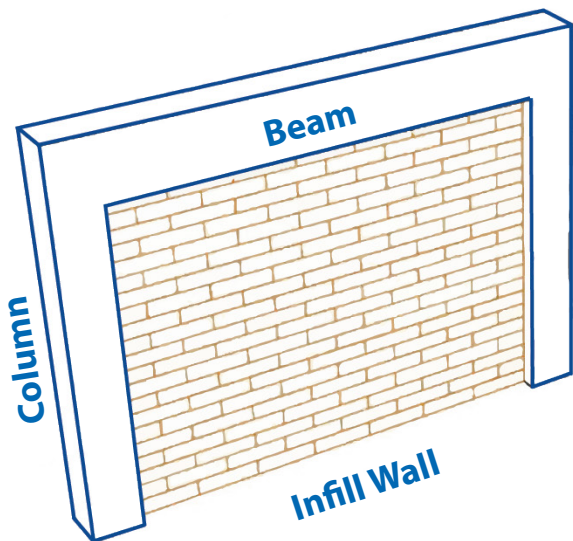
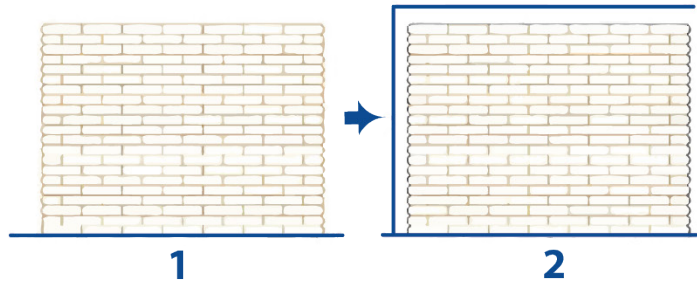
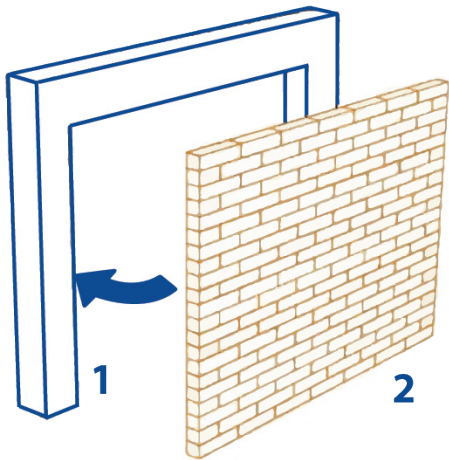

**Infill Wall**  
**Figure 3a**

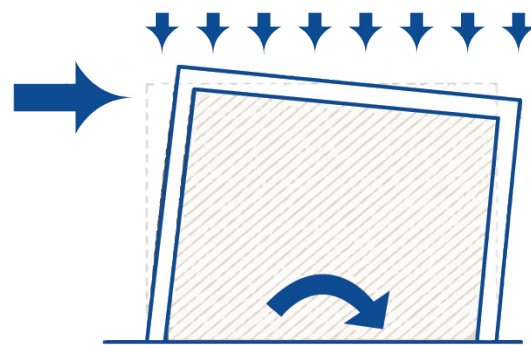

**Load Bearing Wall**  
**Figure 3b**

# GUIDE TO DOMINICA'S HOUSING STANDARDS

## THE WALLS

---

### **RC FRAMES WITH MASONRY INFILL WALLS AND CONFINED MASONRY: A COMPARISON**

The appearance of a finished confined masonry construction and a RC (Reinforced Concrete) frame infilled with masonry wall panels may look alike, however these two construction systems are substantially different, as illustrated in Figure 3 (note that Figure 3a shows features of RC frames with infills, while Figure 3b shows confined masonry construction).

The main differences are related to:

- i) the construction sequence, and
- ii) the manner in which these structures resist gravity and lateral loads.

The differences related to the construction sequence are as follows:

- In confined masonry construction, masonry walls are constructed first, one story at a time, followed by the cast in-place RC tie-columns. Finally, RC tie-beams are constructed on top of the walls, simultaneously with the floor/roof slab construction.
- In RC frame construction infilled with masonry wall panels, the frame is constructed first, followed by the masonry wall construction.

# GUIDE TO DOMINICA'S HOUSING STANDARDS

## THE WALLS

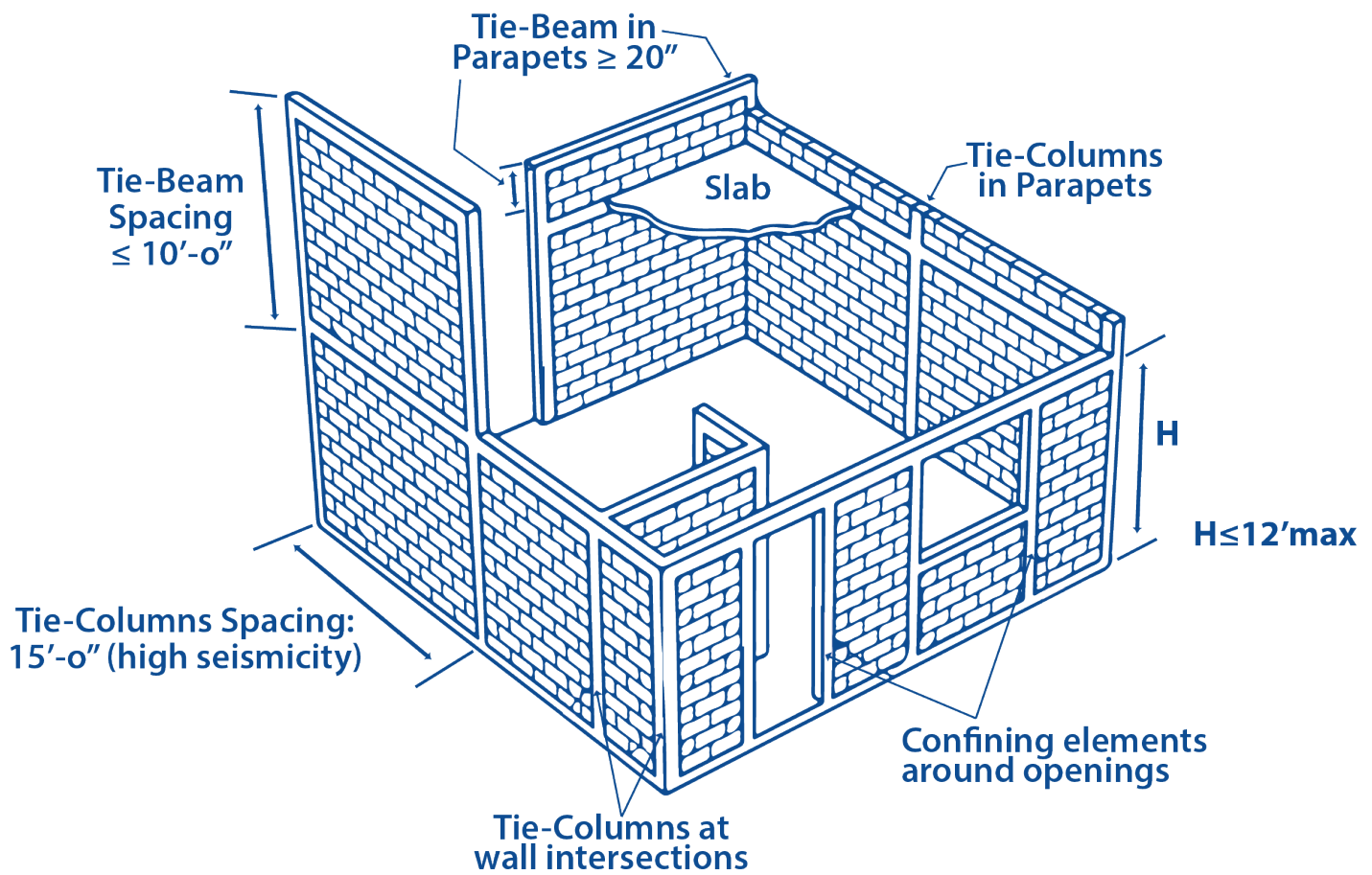

Key recommendations for non-engineered confined masonry buildings (adapted from NTC-M, 2004)

# GUIDE TO DOMINICA'S HOUSING STANDARDS

## THE WALLS

### Minimum Dimensions:

- Tie-Column Size (Depth x Width): 6"min.
- Tie-Beam Size: same as tie-column size

### Reinforcement (Tie-Columns):

- Minimum 4 reinforcing bars
- Bar sizes:
  - deformed reinforcing bars of minimum #4 bars (1/2" diameter)

To ensure the effectiveness of tie-beams in resisting earthquake loads, longitudinal bars should have a 90° hooked anchorage at intersections, as shown below.

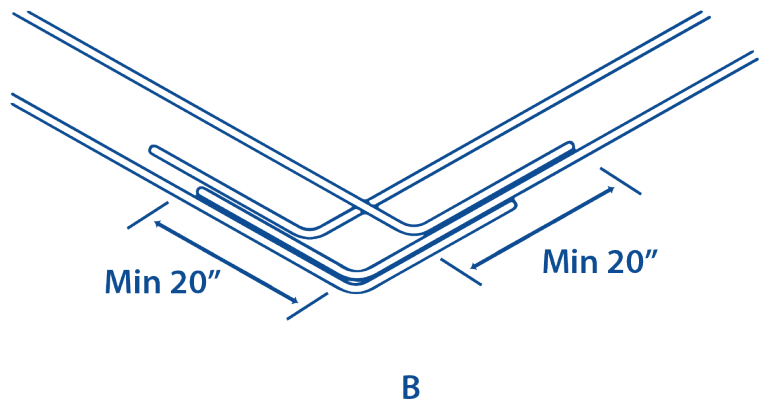
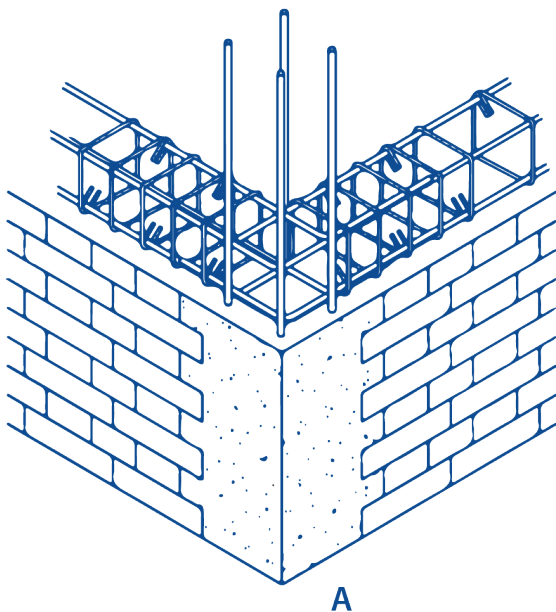

Tie-beam construction: a) wall intersections; b) hooked anchorage for longitudinal reinforcement is a must (Brzev, 2008)

# GUIDE TO DOMINICA'S HOUSING STANDARDS

## THE WALLS

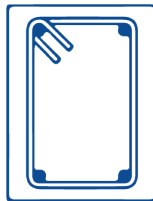
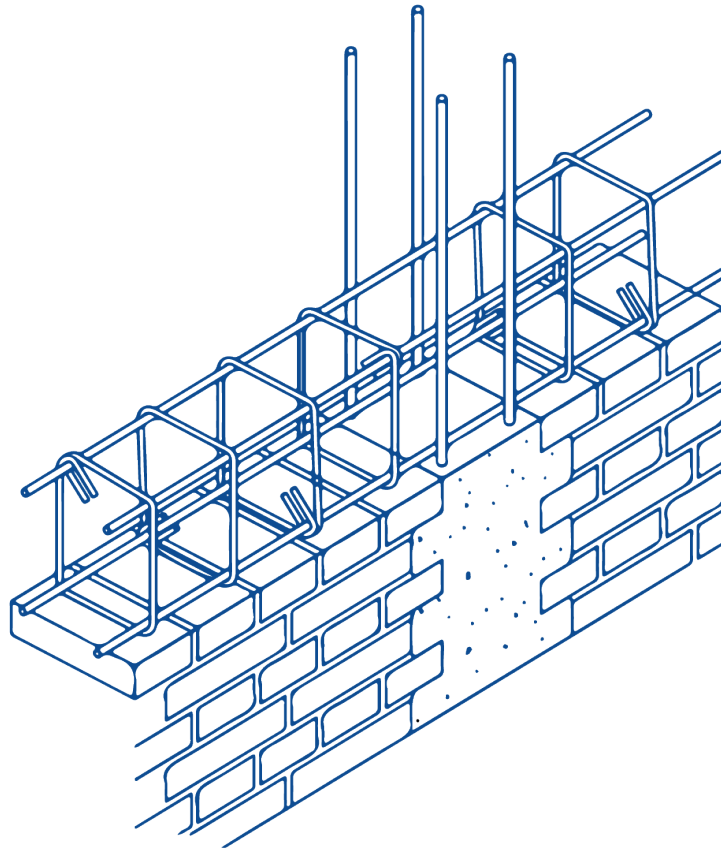

Tie-Beam Cross Section



a) Continuous tie-beam reinforcement

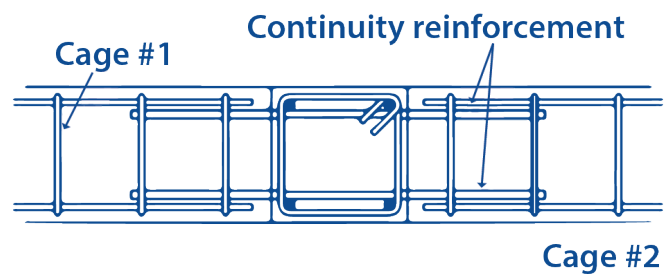

b) Discontinuity prefabricated cages

Plan View

Tie-Beam reinforcement details: a) continuous tie-beam reinforcement, and b) discontinuity reinforcement must be added when prefabricated reinforcement cages are used.

# GUIDE TO DOMINICA'S HOUSING STANDARDS

## THE WALLS

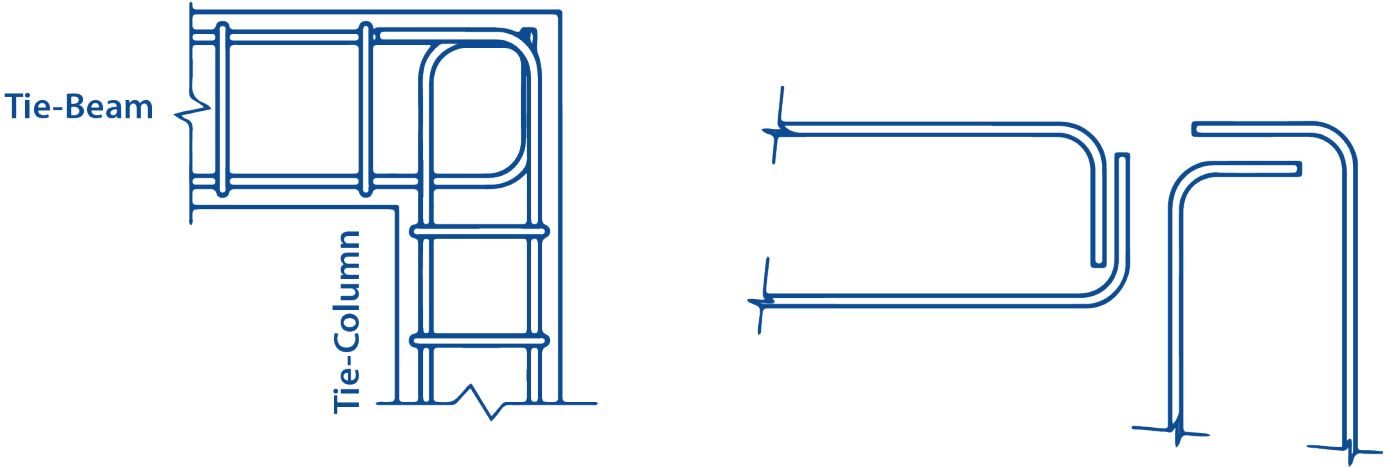

### ELEVATION

Figure 48. Anchorage of tie-beam and tie-column longitudinal reinforcement (Alcocer et al., 2003).

**CONCRETE MIX**

- Concrete strength > 3000psi @ 28 days
- 1 cf cement:2 cf sand:4 cf stone mix suggested
- Water usage limited to 6 gallons

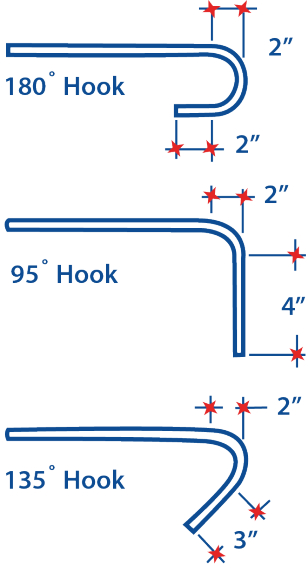

**STRAIGHT BAR LAPS**

- $\frac{3}{8}$ " – 18"
- $\frac{1}{2}$ " – 24"
- $\frac{5}{8}$ " – 30"
- $\frac{3}{4}$ " – 36"

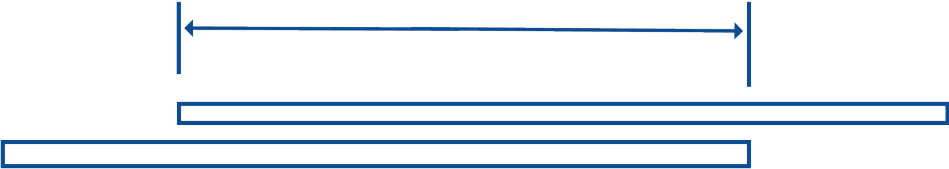

TYPICAL MINIMUM LAP SPLICE  
FOR REINFORCING BARS

# GUIDE TO DOMINICA'S HOUSING STANDARDS

## THE WALLS

### WOODEN WALLS

- The uprights (or posts) are fixed to the wall sill which is bolted to the foundation walls.
- Using metal straps fastened with screws improves the hurricane resistance of timber houses. It is a required feature for these types of buildings. Plywood can be used as an alternate to diagonal braces. Plywood shall be nailed with 10 d nails, 6" o/c at supports and 4" o/c at edges

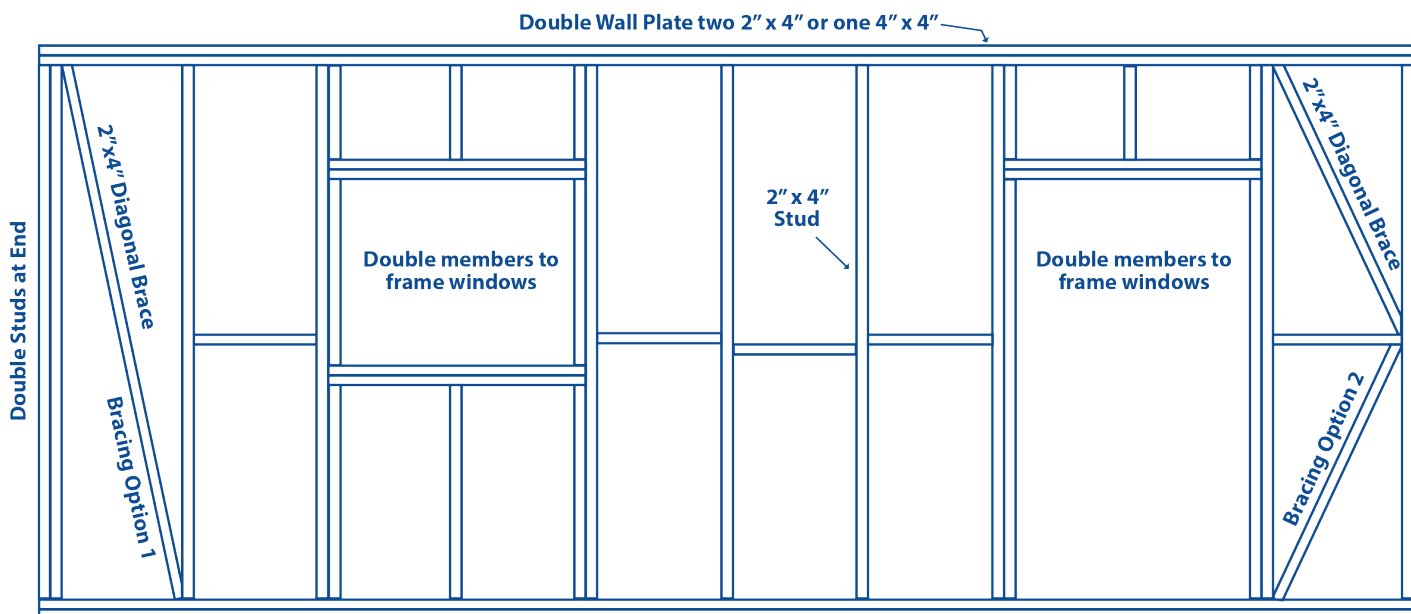

**TIMBER WALL FRAME**

# GUIDE TO DOMINICA'S HOUSING STANDARDS

## THE WALLS

### TIMBER WALLS

In timber houses, the rafters or trusses are connected to a wall plate which is supported by the vertical posts. Two connections need to be considered:

- The first is the connection between the plate and the uprights, which should be made using metal straps. The conventional solution is a mortise and tenon joint (Figure A) using glue and sometimes dowel pins. Suction forces on the roof may cause this joint to fail.
- The second connection is that between the rafter and the plate. It is **REQUIRED** that hurricane straps be used for these connections. Nailing or spiking the rafter to the wall plate is not allowed, as under high suction forces these nails or spikes may pull out.

Hurricane straps or metal connectors shall be designed for "High Wind Construction" and have a "High Corrosion" rating.

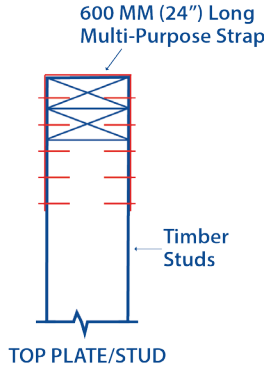
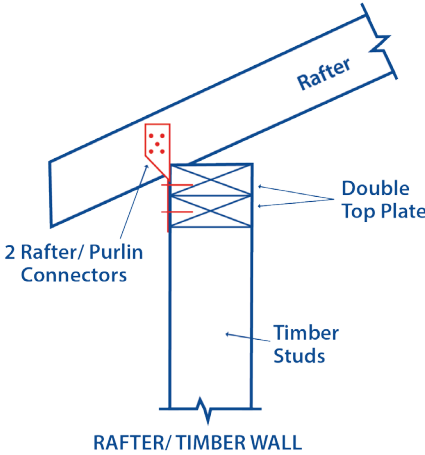
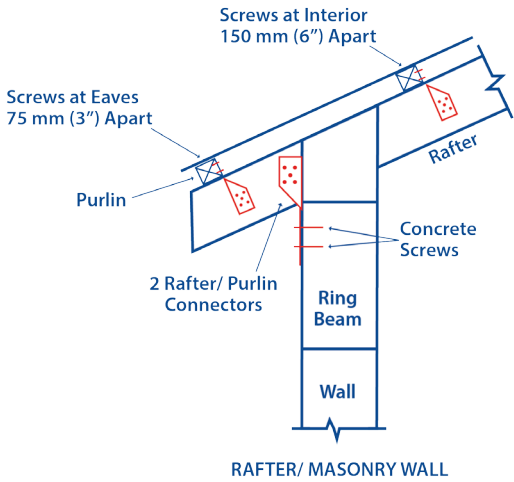
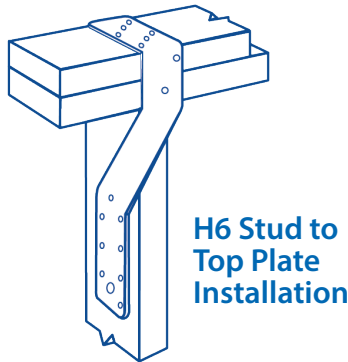
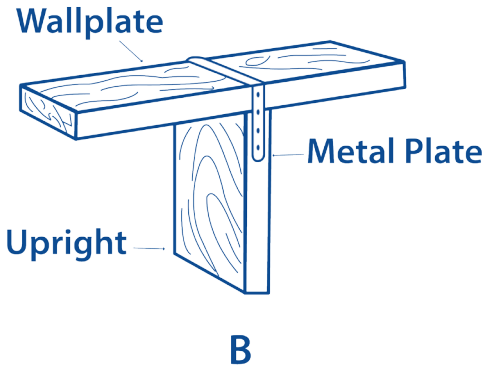
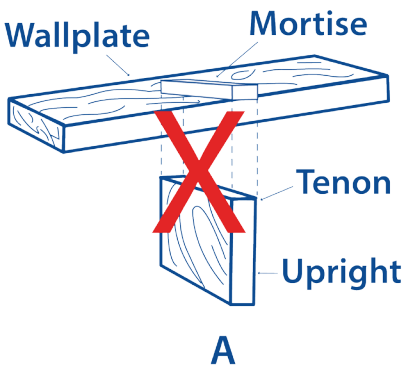

# GUIDE TO DOMINICA'S HOUSING STANDARDS

## THE WALLS

The walls must be securely tied to the foundation to prevent the wind forces lifting up the entire building or blowing it over.

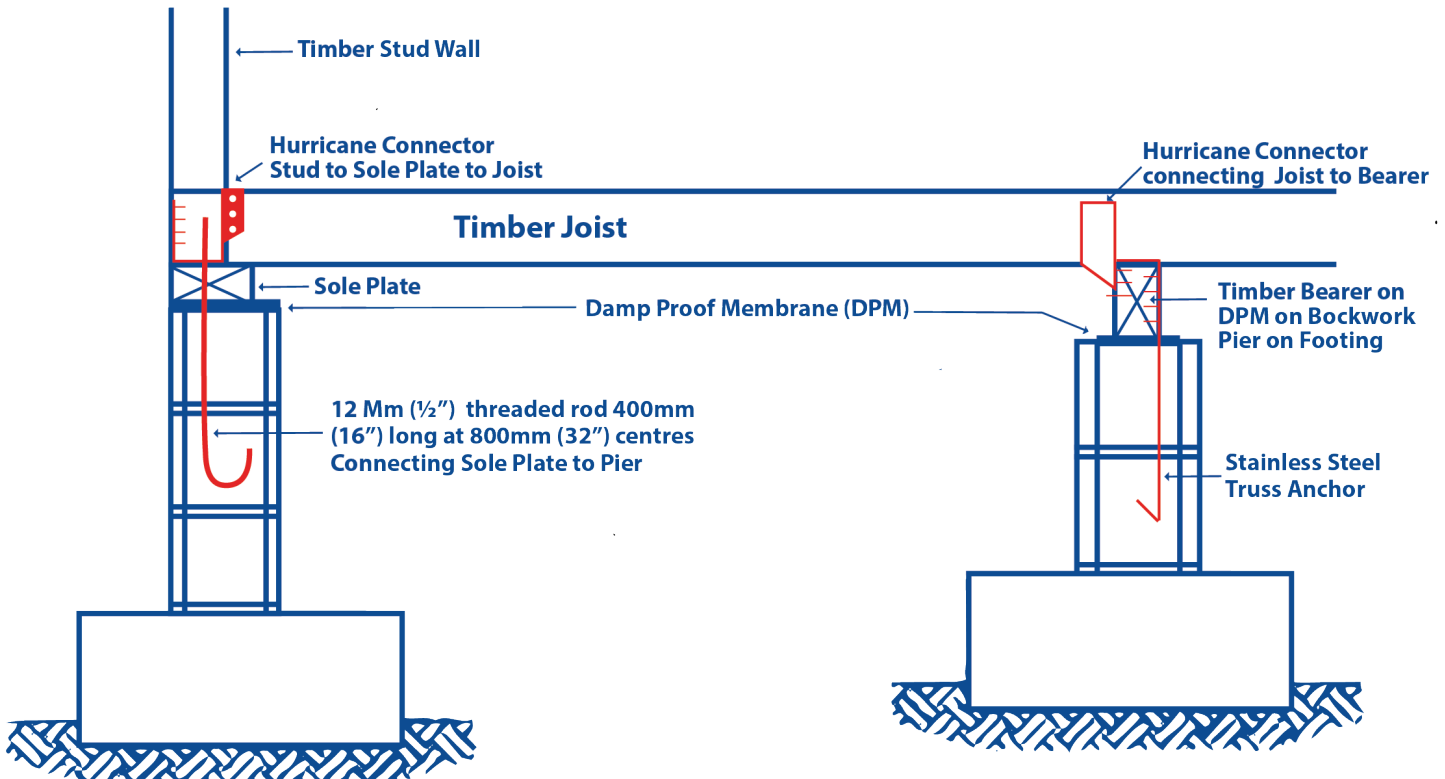

### CONNECTION WITH HURRICANE STRAPS

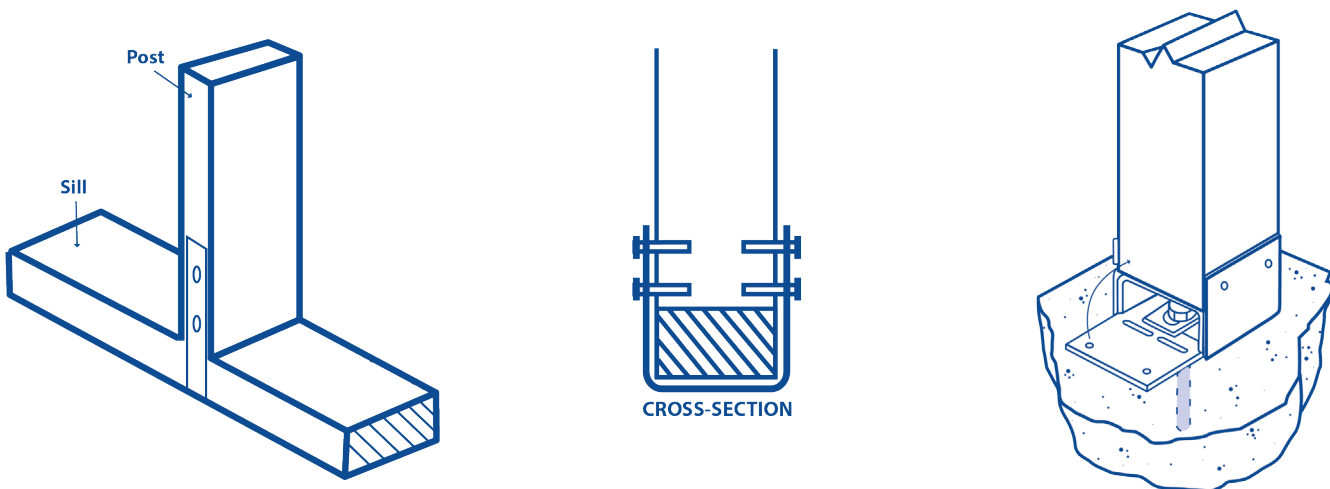

# GUIDE TO DOMINICA'S HOUSING STANDARDS

## THE WALLS

### TIMBER WALL INTERSECTIONS

Walls should be braced across corners at plate level and at both corners of each wall.

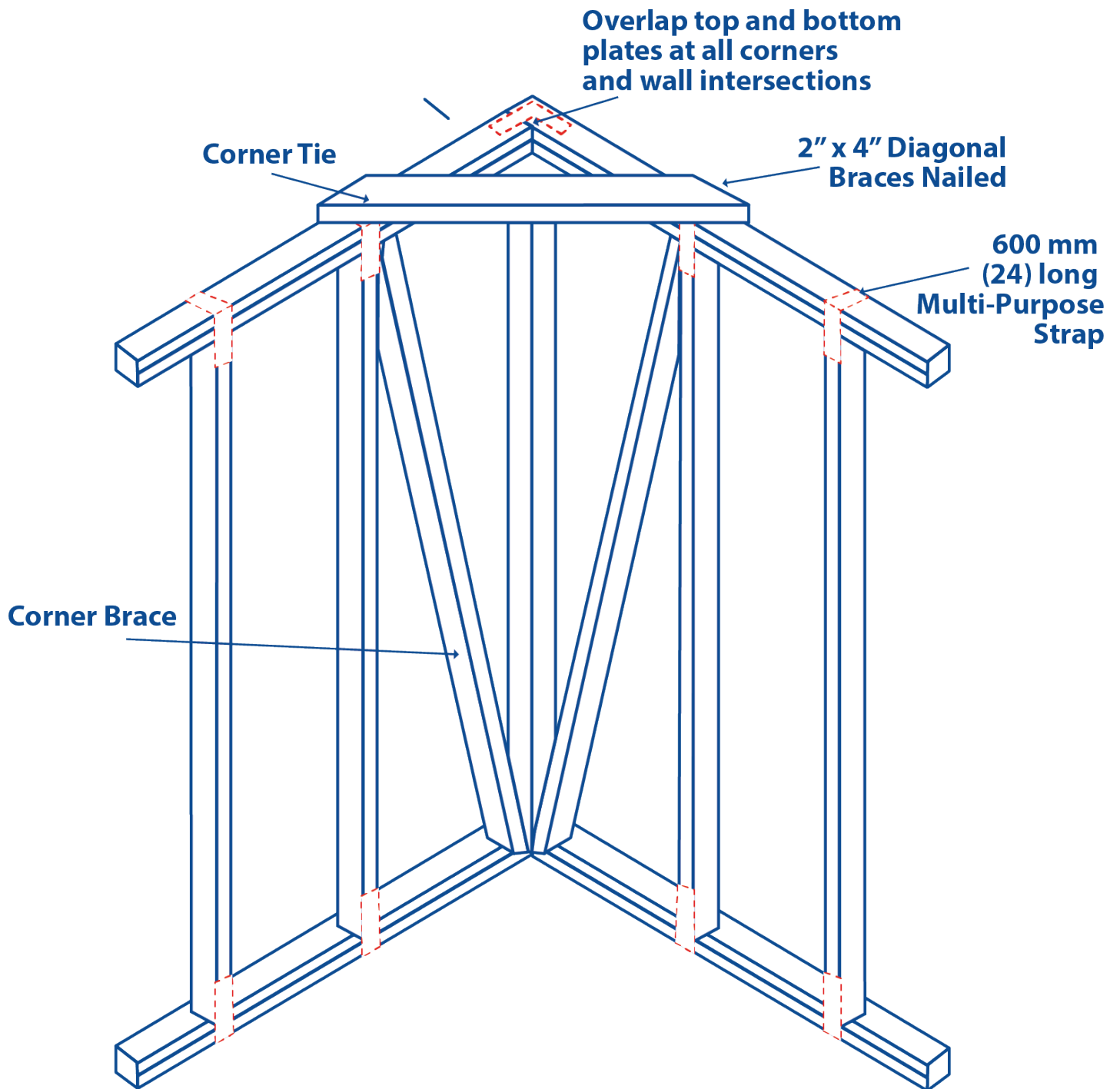

# GUIDE TO DOMINICA'S HOUSING STANDARDS

## THE WALLS

### SHEAR WALLS

A structural system composed of braced panels to counter/resist the effects of lateral loads (forces) acting against the structure. Winds and seismic loads are the most common loads shear walls are designed to carry.

#### Shear Walls - Timber

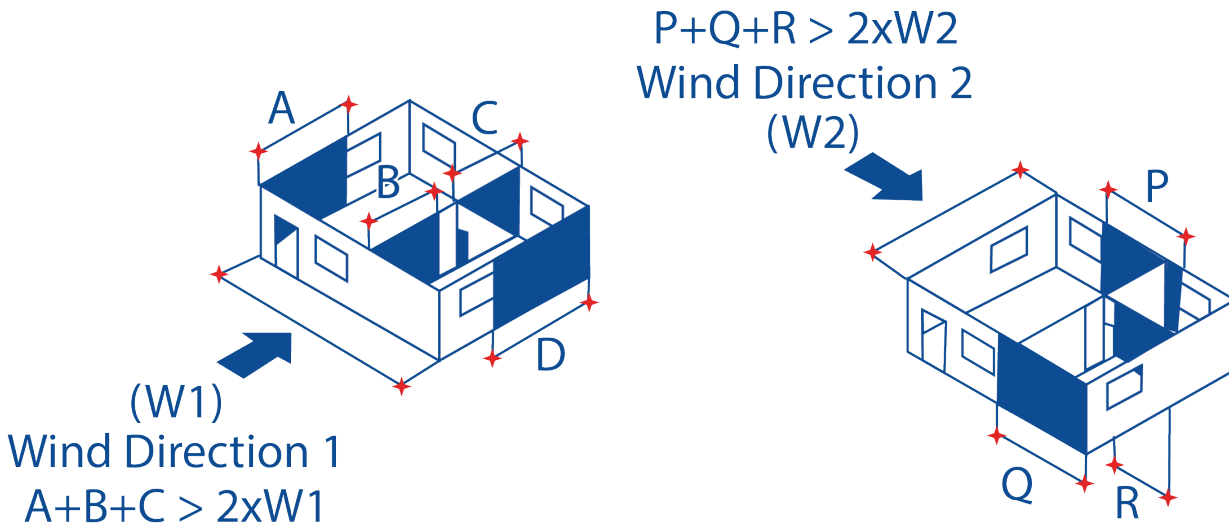

#### Shear Walls - Masonry

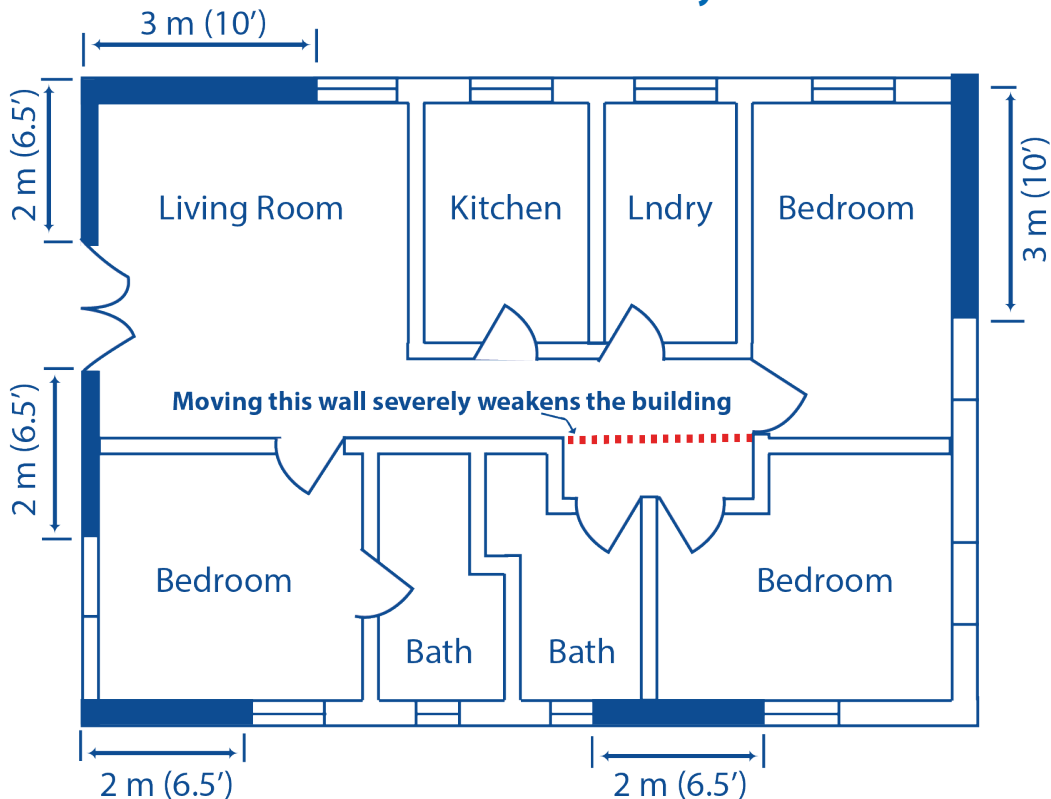

# GUIDE TO DOMINICA'S HOUSING STANDARDS

## THE WALLS

### WALL OPENINGS

Avoid openings which cannot be securely closed during a hurricane.  
Where openings are already in existence, hurricane shutters should be provided.

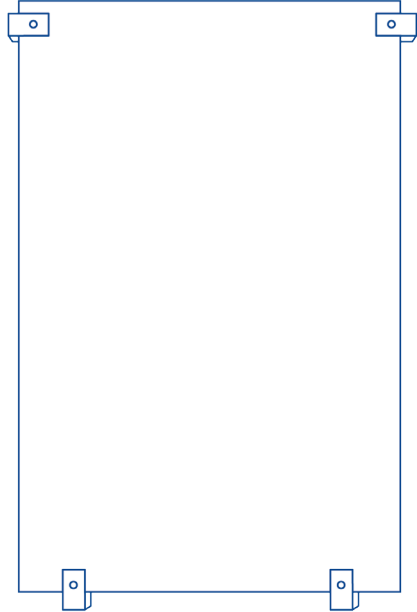
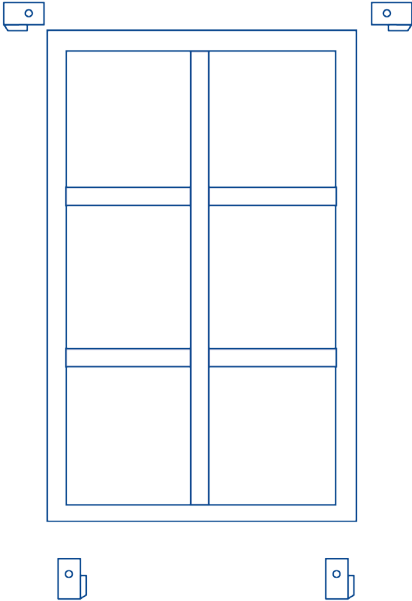
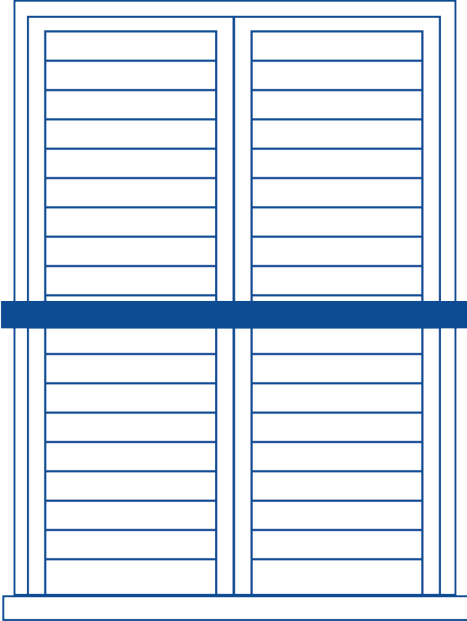
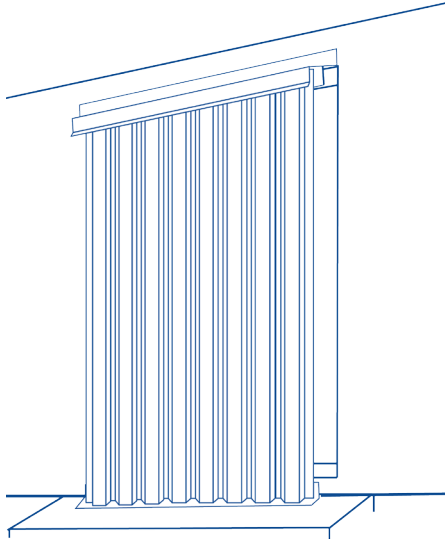
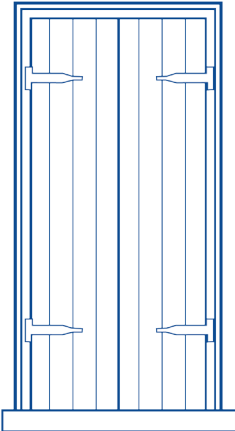
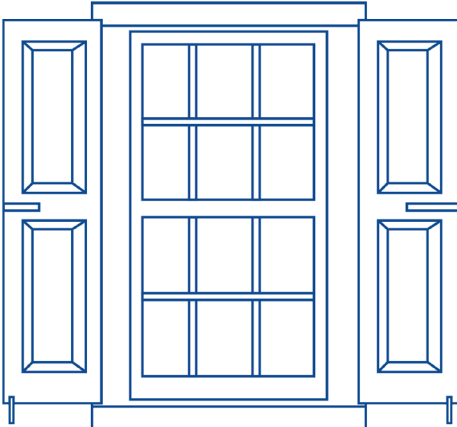

# GUIDE TO DOMINICA'S HOUSING STANDARDS

## THE ROOF

### ROOF DESIGN

Lightweight flat roofs are easily blown off in high winds. In order to lessen the effects of the uplifting forces on the roof, the roof pitch shall not be less than 25°(6:12).

Hip roofs have been found to be more hurricane resistant than gable roofs.

Use a hip or a high pitched gable roof.



**HIP ROOF**



**GABLE ROOF**

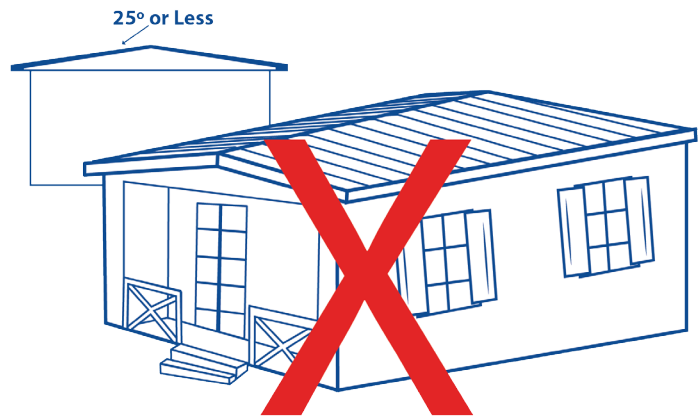

**FLAT ROOF**

# GUIDE TO DOMINICA'S HOUSING STANDARDS

## THE ROOF

### HIP ROOF DESIGN

**EXPERIENCE AND EXPERIMENT HAVE SHOWN THAT THE HIP ROOF WITH A PITCH BETWEEN 25° - 40° (6:12 – 10:12) HAS THE BEST RECORD OF WIND RESISTANCE.**

All sides of a hip roof are sloped. There are no gable ends in this roof. Instead, rafters (hip rafter) come across diagonally from the corner to meet the ridge board a short distance from the ends of the house. Other shorter rafters going from the wall plate to the hip rafter are known as jack rafters. Once the ridge is firmly in position, the rafters are attached to fit neatly onto the wall plate.

#### HIPPED ROOF

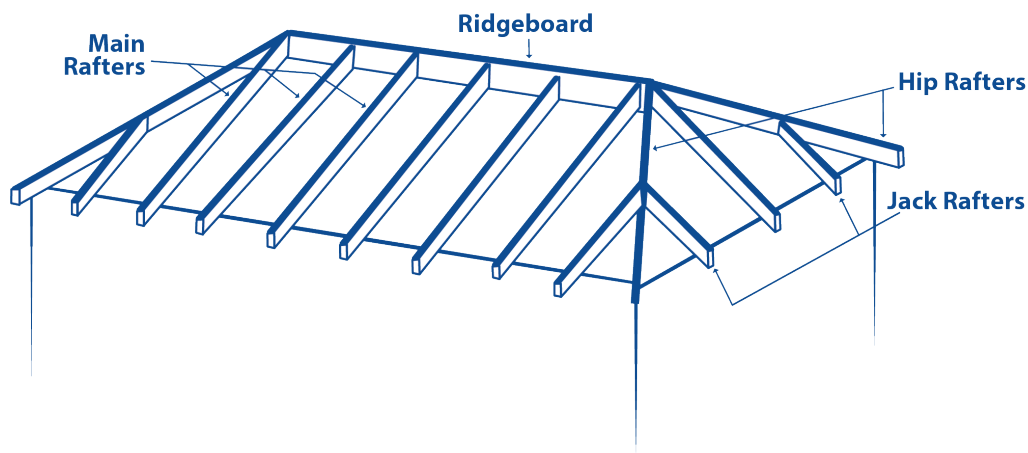

25° to 40°



#### Minimum Rafter Sizes

Ridge: 2"x8"

Hip Rafters: 2"x8"

Jack Rafters: 2"x6"

Common Rafters 2"x6"

# GUIDE TO DOMINICA'S HOUSING STANDARDS

## THE ROOF

---

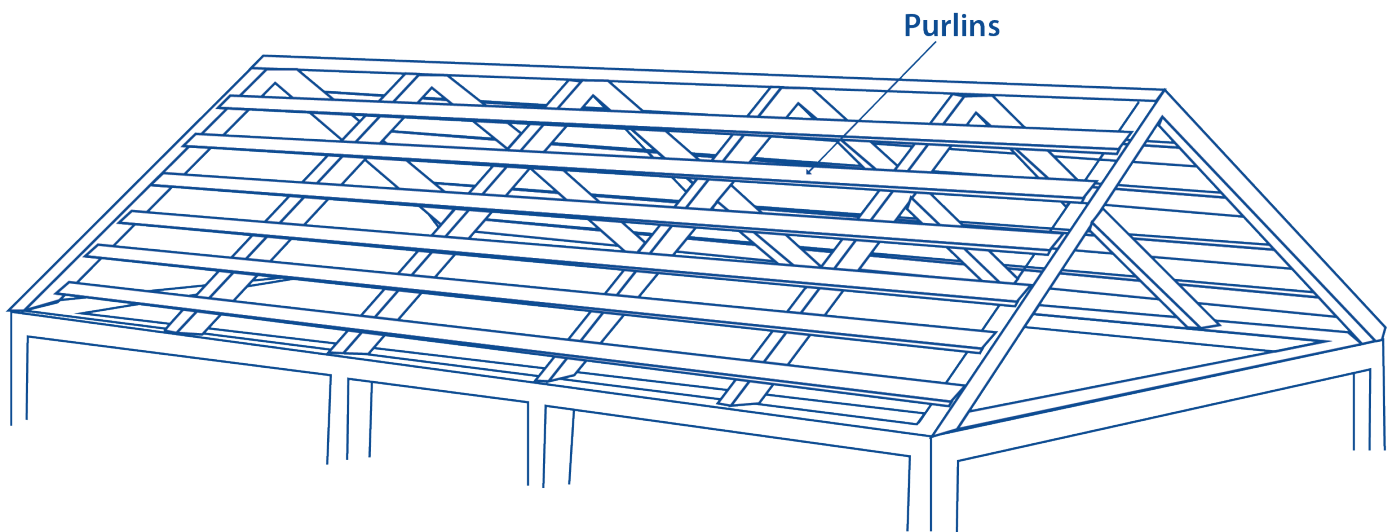
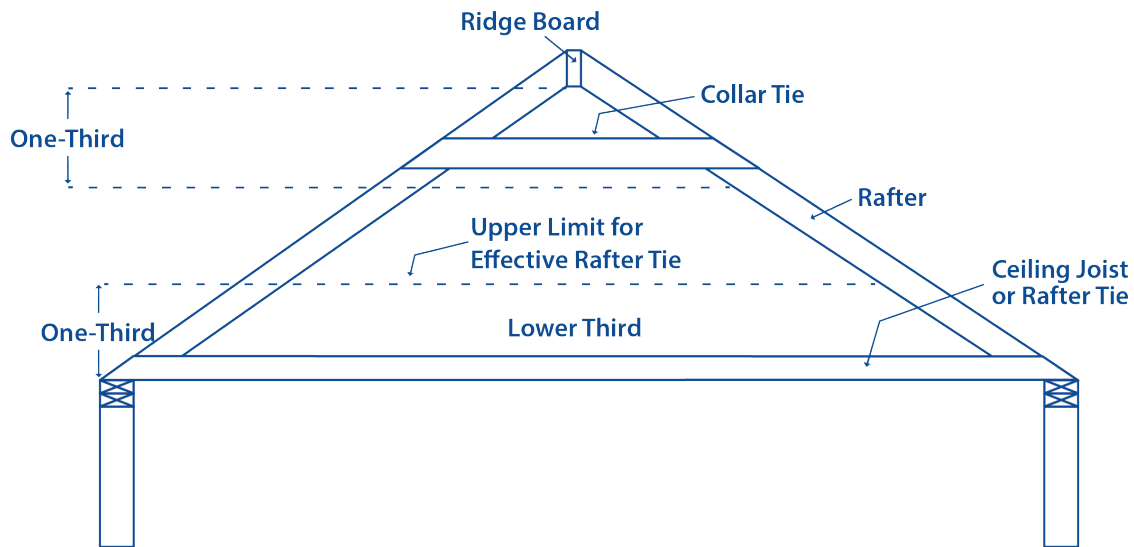

# GUIDE TO DOMINICA'S HOUSING STANDARDS

## THE ROOF

### Dominica (160 mph wind speed)

#### ROOF JOIST/ RAFTER SPAN #2

		10' or less	12'	14'	16'	18'	20'
<b>SPACING</b>	12" o.c.	2 x 6	2 x 6	2 x 6	2 x 8 / 3 x 6	2 x 8 / 3 x 6	2 x 10
	16" o.c.	2 x 6	2 x 6	2 x 8 / 3 x 6	2 x 8 / 3 x 6	2 x 10	2 x 10
	19.2" o.c.	2 x 6	2 x 8 / 3 x 6	2 x 8 / 3 x 6	2 x 10	2 x 10	None
	24" o.c.	2 x 6	2 x 8 / 3 x 6	2 x 10	2 x 10	None	None

#### CEILING JOIST SPAN - SOUTHERN PINE #2 (no attic storage)

		10' or less	12'	14'	16'	18'	20'
<b>SPACING</b>	12" o.c.	2 x 6	2 x 6	2 x 6	2 x 6	2 x 6	2 x 8 / 3 x 6
	16" o.c.	2 x 6	2 x 6	2 x 6	2 x 6	2 x 8 / 3 x 6	2 x 8 / 3 x 6
	19.2" o.c.	2 x 6	2 x 6	2 x 6	2 x 6	2 x 8 / 3 x 6	2 x 8 / 3 x 6
	24" o.c.	2 x 6	2 x 6	2 x 6	2 x 8 / 3 x 6	2 x 8 / 3 x 6	2 x 8 / 3 x 6

# GUIDE TO DOMINICA'S HOUSING STANDARDS

## THE ROOF

When the wind passes over the roof it sucks the roof upwards and the roof can pull apart. The ridge must be held together. This shall be done by using rafter to ridge straps.

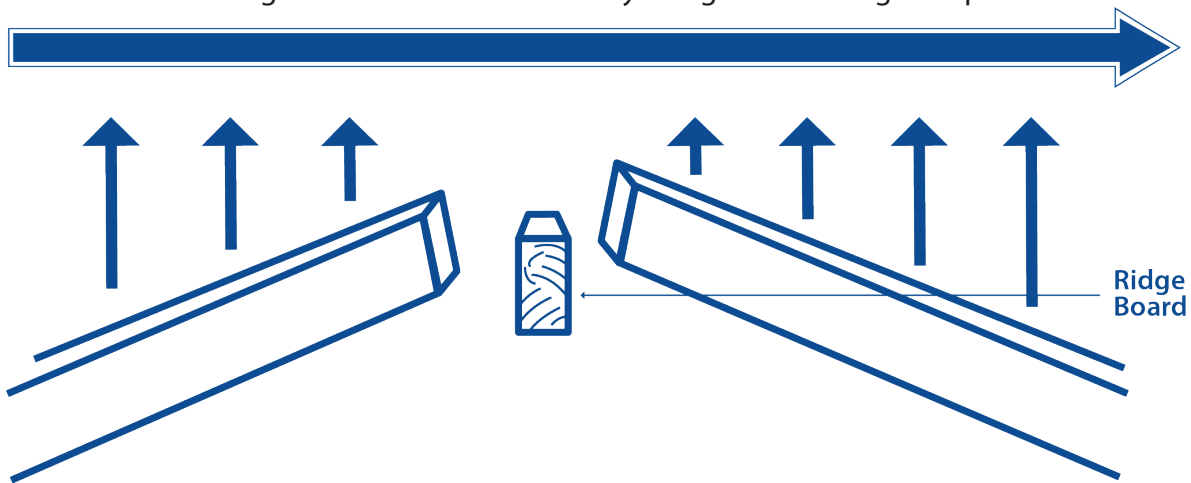

If the rafters are not secure, the ridge can fall apart when strong wind passes over the roof.

### 2" x 4" COLLAR TIES ON EVERY RAFTER

Screw timbers connecting the rafters to the side of the rafters, not the face.

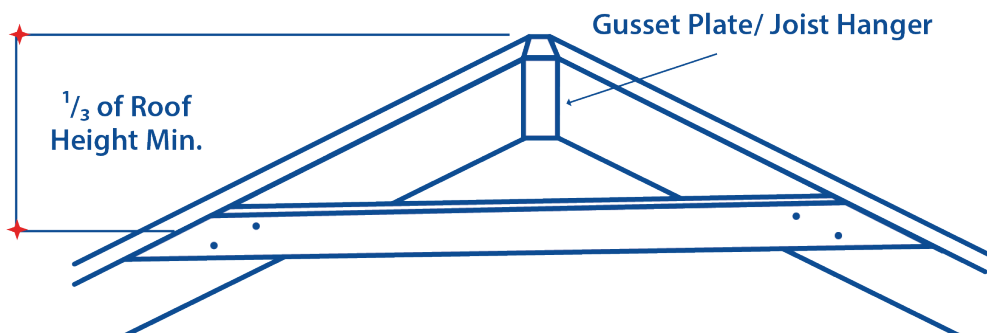

### TRUSS SYSTEM

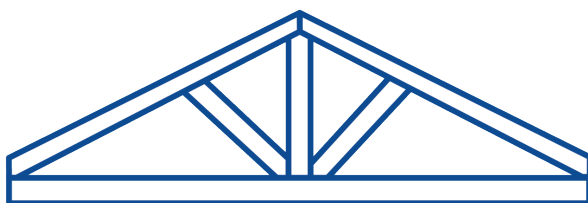

HUNTSMAN

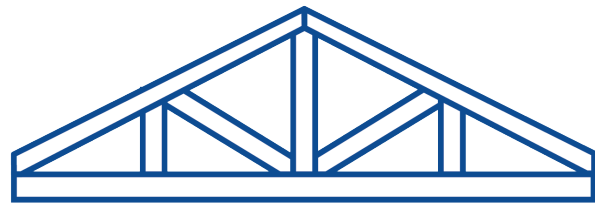

SAWTOOTH

Depending on the span of the roof, a truss system may need to be constructed in place of collar ties.

# GUIDE TO DOMINICA'S HOUSING STANDARDS

## THE ROOF

Overhangs, patios and verandahs experience high wind pressures and should be kept short, small and separated from the structure.

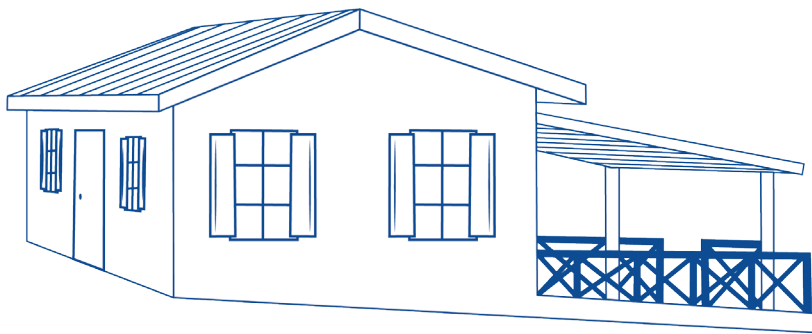
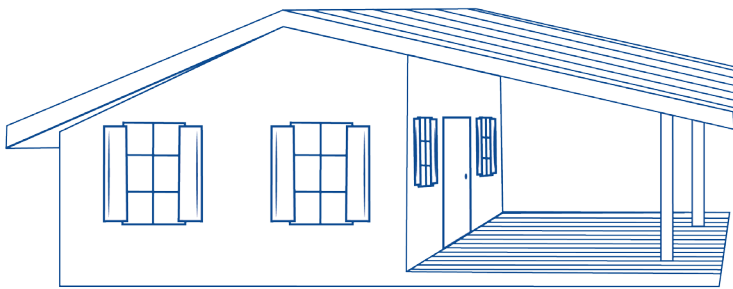

- Overhangs **shall not be more** than 18" at the eaves.
- Build verandah and patio roofs as separate structures rather than extensions of the main building.

When properly constructed, the overhangs, patios and verandas may blow off without damaging the rest of the house.

# GUIDE TO DOMINICA'S HOUSING STANDARDS

## THE ROOF

Corrugated galvanize (zinc) sheets are gauged by numbers. The higher the number the thinner the material.

Example: 24 gauge galvanize is superior to 26 gauge.

How does roof sheeting fail in hurricanes?

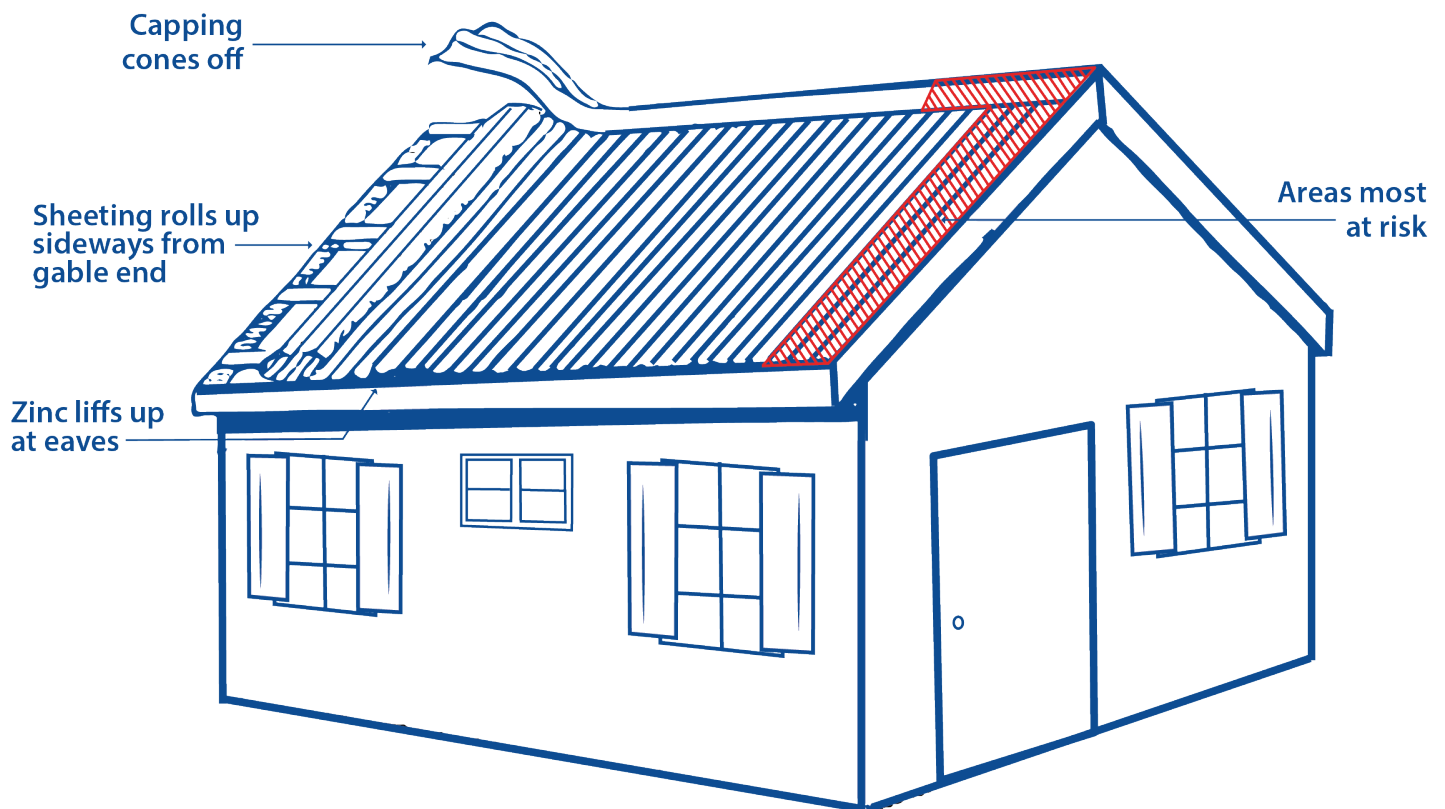

# GUIDE TO DOMINICA'S HOUSING STANDARDS

## THE ROOF

### FAILURE IN ROOFS

IF THE SHEETING IS TOO THIN OR THERE ARE TOO FEW FITTINGS, THE SCREWS TEAR THROUGH THE SHEET.

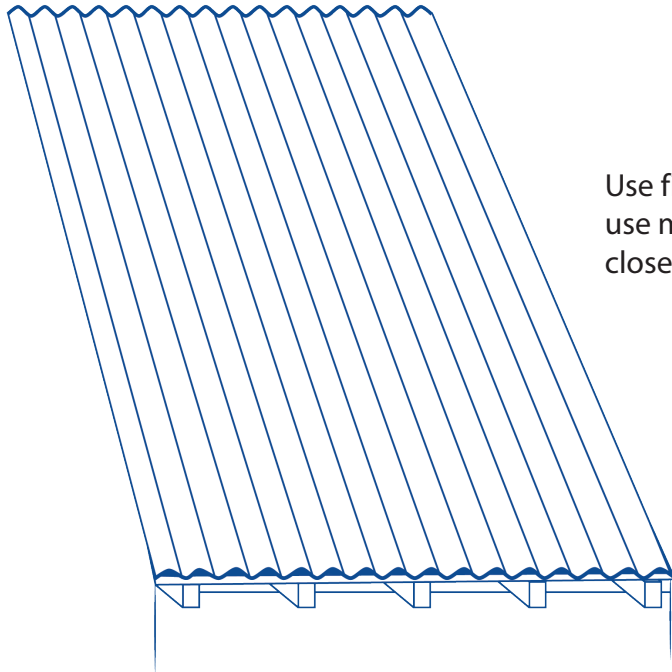

Use fittings with a broad washer or dome head. To use more fixings for each sheet, put in the laths at closer centers and screw closer together.

To prevent this type of failure, use more fixings for thinner sheeting.

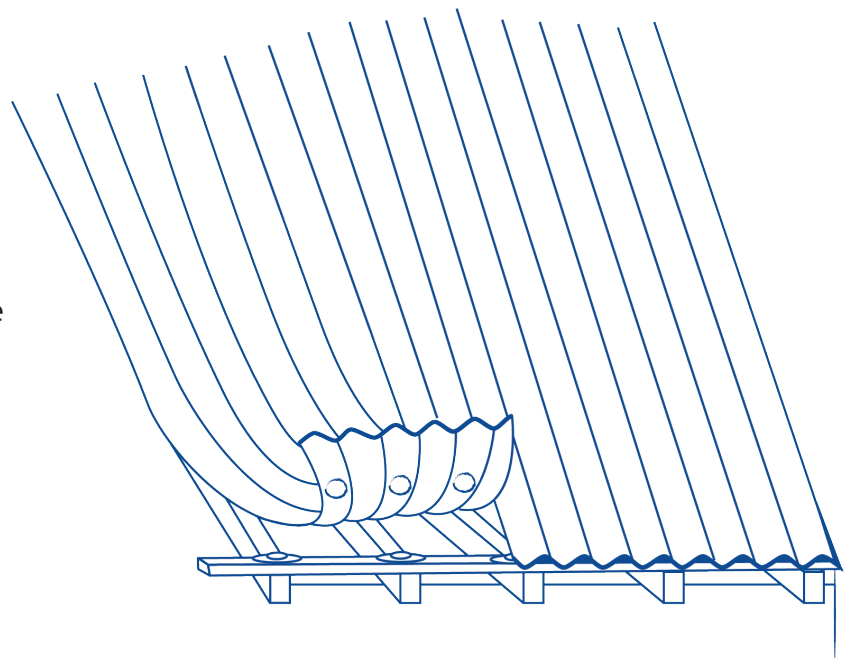

# GUIDE TO DOMINICA'S HOUSING STANDARDS

## THE ROOF

### ROOFING MATERIALS GALVANIZED SHEETS

WHEN GALVANIZED SHEETS ARE USED 24 GAUGE IS REQUIRED.

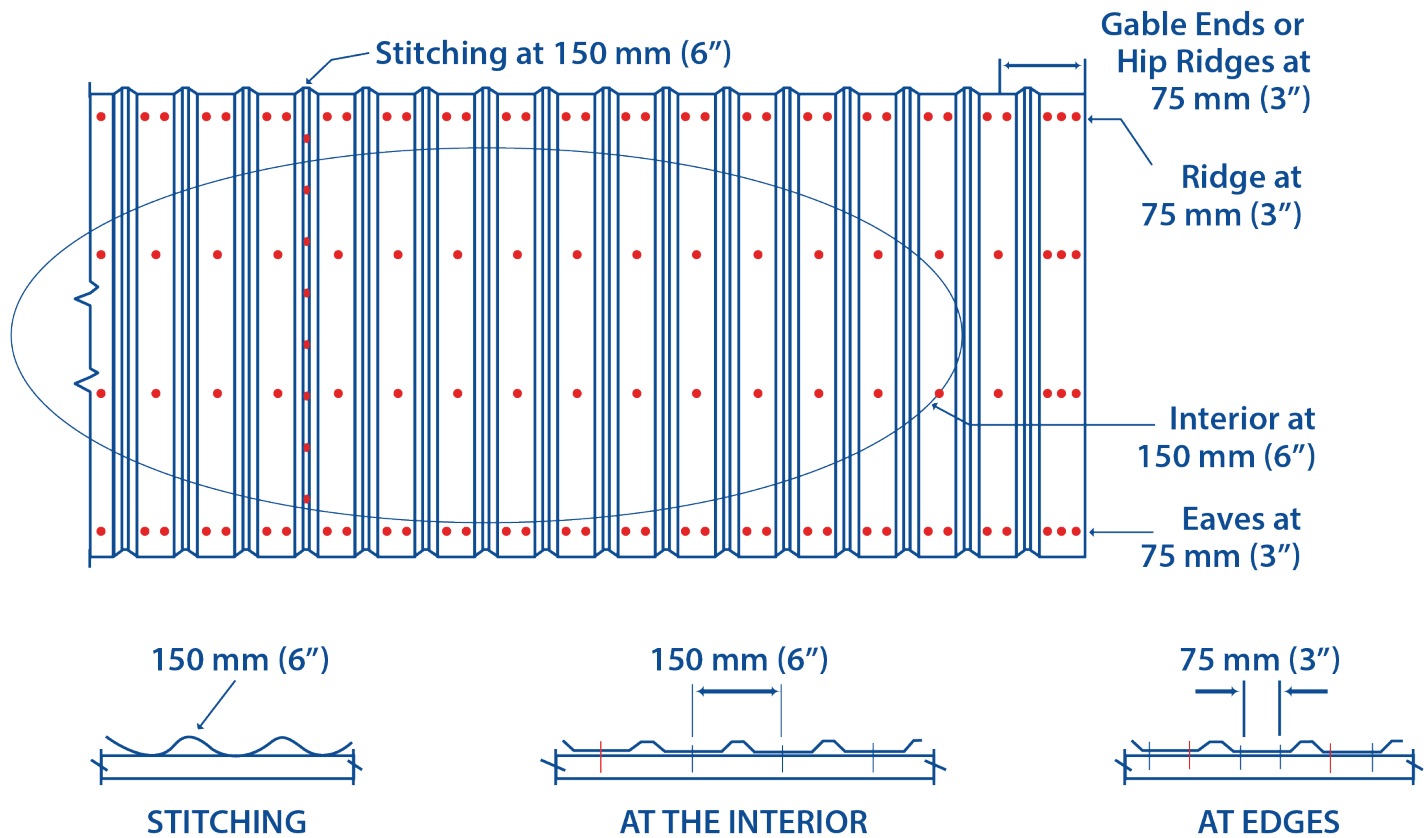

At ridges, eaves and overhangs - #9 (2½") screws every 3". All other locations, #9 screws every 6". Neoprene washers allow screws to be attached at the valley of the corrugation.

# GUIDE TO DOMINICA'S HOUSING STANDARDS

## THE ROOF

### FIXINGS FOR SHEETINGS

- Use proper drive screws for corrugated galvanized roof sheets. #9 screws 2½ minimum.
- Be sure that the screws go into the purlins **at least two (2) inches**.
- Use driving heads or large washers under the screw heads to prevent the roof sheets from tearing when pulled upwards by high winds.
- Remember to use sufficient screws so that the heads will not tear through.
- The corrugation sheeting should be properly overlapped at least 2½ corrugation to prevent water from blowing under the seam.
- Roof capping should be made from material as strong as the sheeting itself and should be screwed down to the purlin on either side of the ridge, ridgeboard or hip.
- Spaces between sheeting and the wall plate should be closed up to prevent the wind from getting under the sheeting and lifting it. This can be done by nailing a fascia board to the ends of rafters.

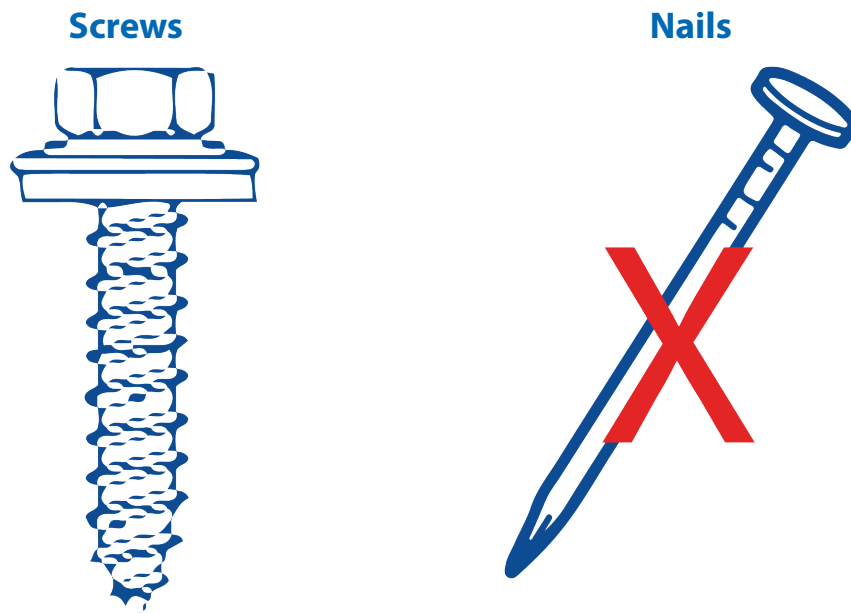

### PURLIN SPACING AND FIXING

- Spacing for 2" x 4" purlins (lath) shall be 2' on centers and fixed to the rafters using hurricane straps or screws with plywood.
- Sheets should be fixed to the purlins using self-tapping screws.

# GUIDE TO DOMINICA'S HOUSING STANDARDS

## THE ROOF

### ROOF CONNECTIONS FOR CONCRETE WALLS

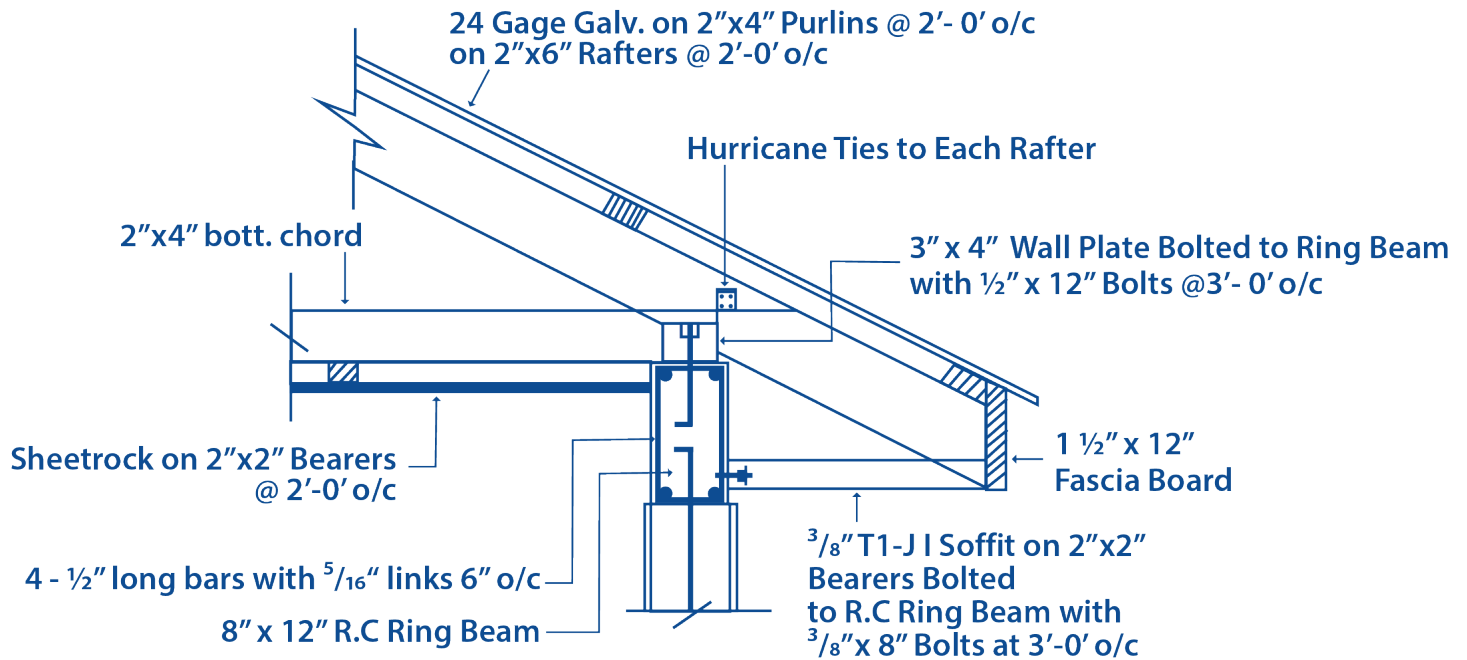

### TYPICAL EAVES DETAIL

If exposed rafters are being used with plywood attached to the rafters, the purlins and galvanized sheets need to be screwed through the plywood using #9 screws - 4 1/2" long min. Use #9 screws 2 1/2" long at 6" spacing between purlins to screw plywood to the rafter.

### GABLE ROOFS

A minimum 10" capping beam at the top of the reinforced concrete block, must be tied to ringbeam of the structure.

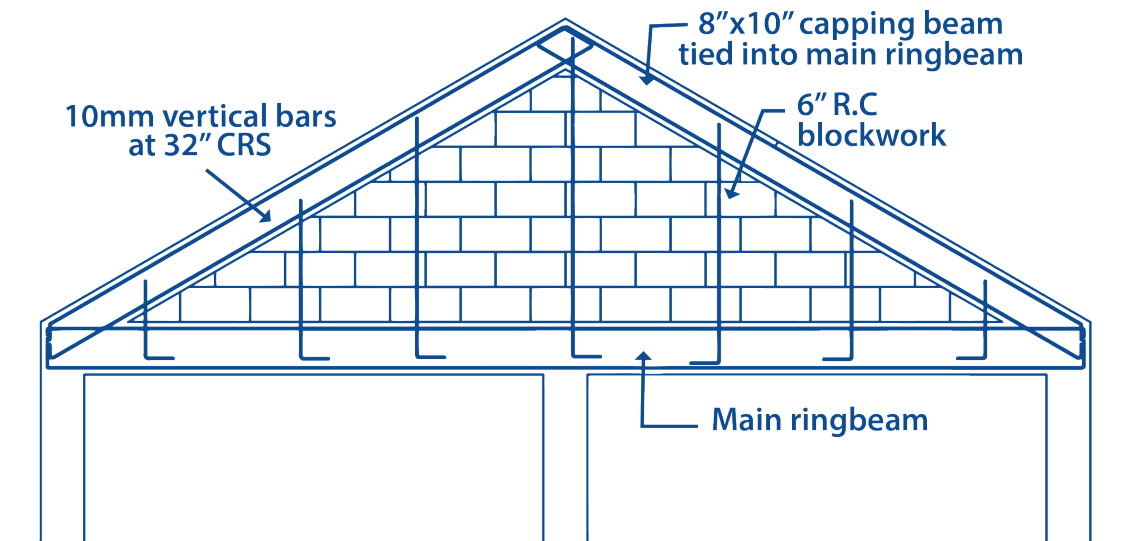

GABLE END DETAIL

# GUIDE TO DOMINICA'S HOUSING STANDARDS RETROFIT

**RAFTERS WILL LIFT OFF WALL PLATES IN HIGH WINDS.  
STRAPS MUST BE INSTALLED IN EXISTING ROOFS TO STRENGTHEN THEM.**

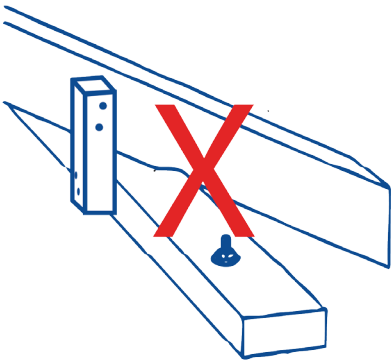

Timber connector may NOT be used as an alternative.

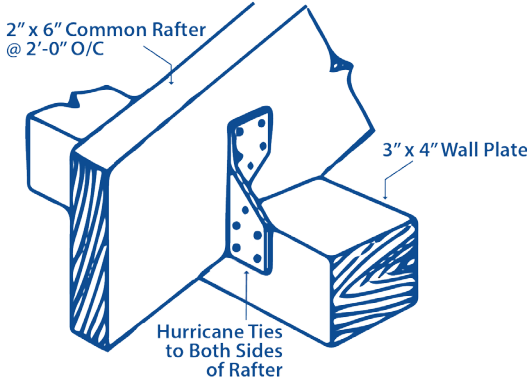

Twisted straps connected per manufacturers specs. Be careful when selecting hurricane straps. Ensure that they can be properly affixed, so that when nailed, they are not too near the edge.

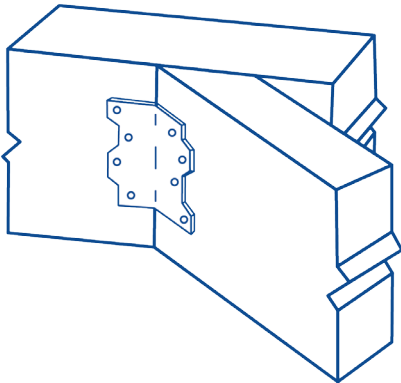

JACK RAFTER/HIP CONNECTION

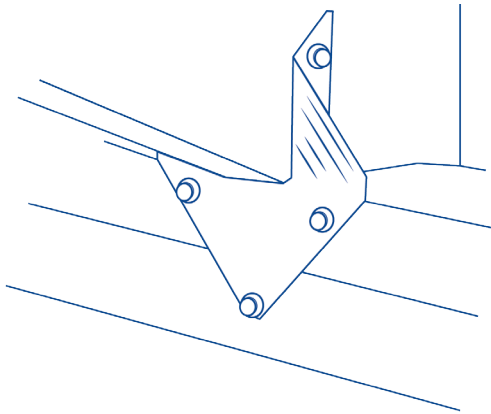

RAFTER/WALL PLATE CONNECTION

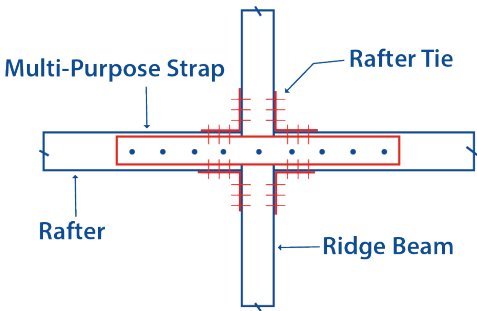

RAFTER/ RIDGE PLAN

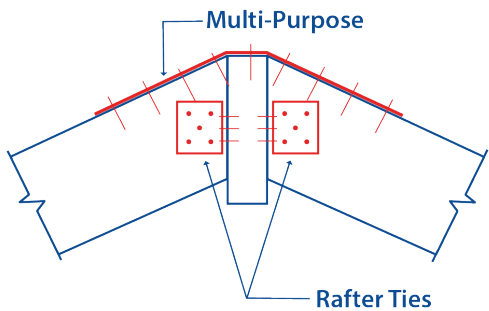

RAFTER/ RIDGE ELEVATION

# GUIDE TO DOMINICA'S HOUSING STANDARDS

## RETROFIT

WALL PLATES FOR WOODEN BUILDINGS ARE CRITICAL BECAUSE THEY PROVIDE STIFFNESS FOR THE BUILDING AND ALSO SERVE TO HOLD THE ROOF DOWN.

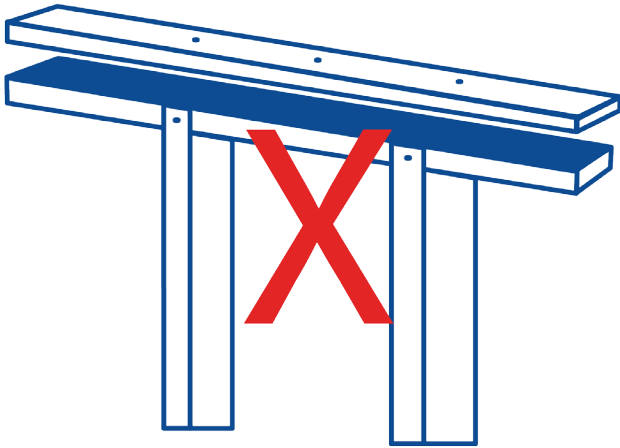

They are often insecurely held down by nails into the end grain of posts.

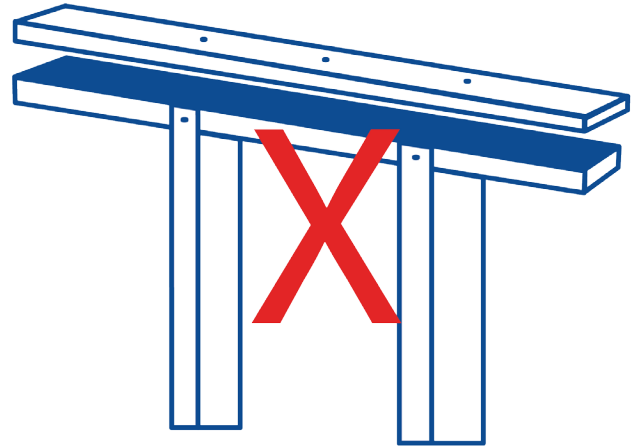

Double plate shall not be used without straps.

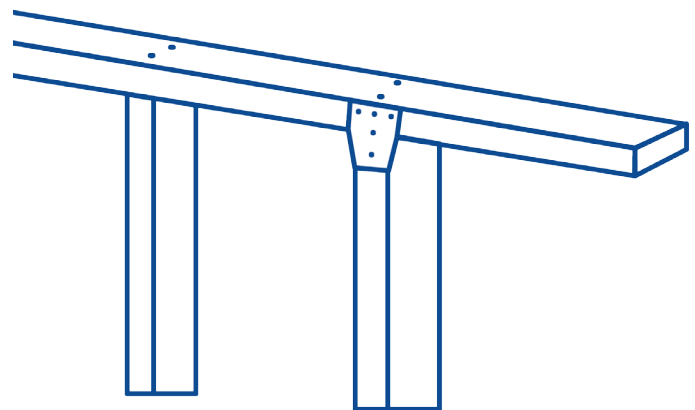
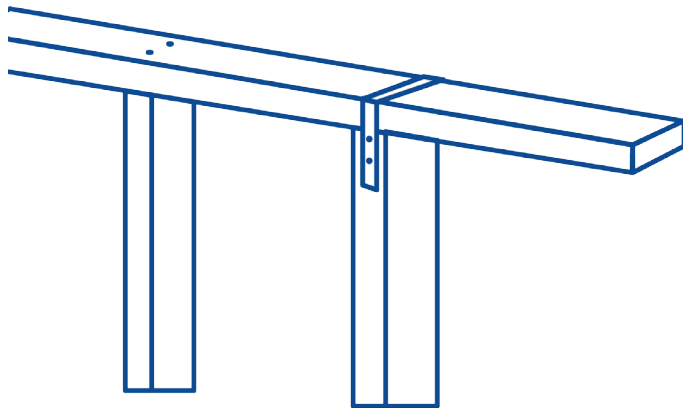

To strength use a strap over the top or Use a gusset of zinc or plywood.

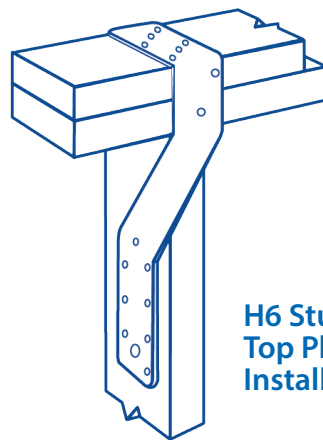

H6 Stud to  
Top Plate  
Installation

# GUIDE TO DOMINICA'S HOUSING STANDARDS

## RETROFIT

**DUE TO FAILURES OBSERVED AFTER RECENT HURRICANES, RAFTERS MAY NOT BE BUILT INTO THE BELT BEAM AT THE TOP OF THE WALL.**

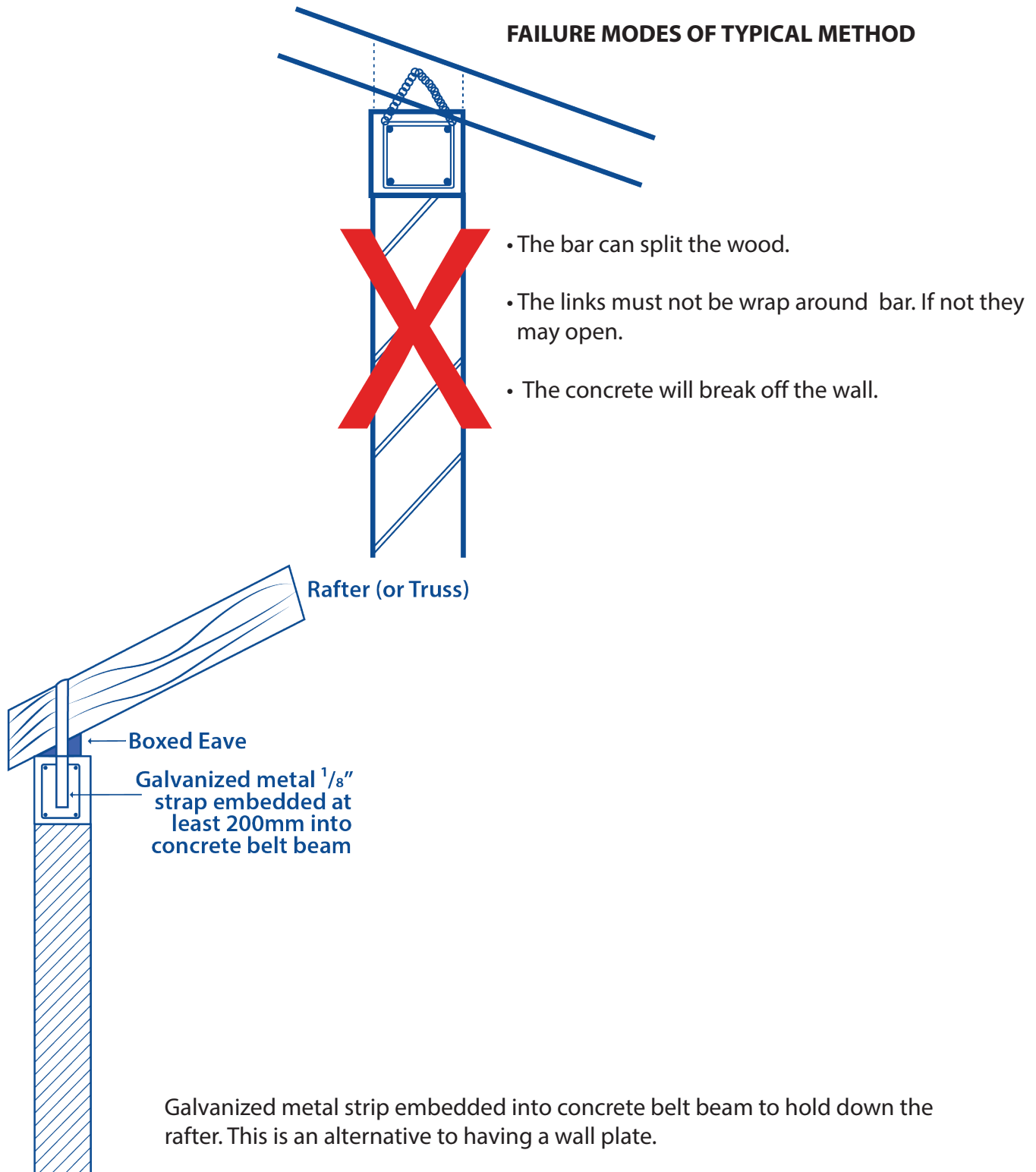

# GUIDE TO DOMINICA'S HOUSING STANDARDS

## MAINTENANCE

---

- Experience and statistics show that the lack of maintenance is a significant contributing factor in damages to houses by hurricanes.
- Regular maintenance is necessary in order to ensure that the structure continues to be hurricane resistant. Inspections should be done at least once a year prior to the hurricane season and, or after any significant weather event.
- Check the entire house regularly, inside and out, to see if anything needs repairing or replacing and fix it immediately.
- The most important areas for regular checks are:
  - Roof cladding for damage and fixing for missing screws or bolts;
  - Roof structure; rafters and purlins for soundness;
  - Joints and connections in timber and masonry construction for structural integrity and durability.
  - Concrete blocks and slabs for cracks;
  - For houses on wooden support:  
check support for rot, especially those below ground level;  
check for termites and treat when evident. Obtain specialist advice for this problem.

# GUIDE TO DOMINICA'S HOUSING STANDARDS

## CONCLUSION

---

- Roof sheeting shall be 24 gauge (0.5 mm) minimum;
- Imported wood shall be grade two (2), pressure treated (APWA UC4A) or better;
- Hurricane ties are required. Hurricane ties shall be galvanized or stainless steel. Clips shall be rated for "High Wind" construction and shall be of "High Corrosion Rating".
  - Stainless Steel shall be used within 300' of the ocean
    - Simpson H3Z or equal for purlin to rafter
    - Two, Simpson H2.5AZ or equal for rafter to wall plate
- Roof sheeting shall be attached by #9 Neoprene Screws with driving head, 2½" in length min.;
- Rafter spacing 24" max.
- Purlin spacing 24" max.
- Rafter lengths of more than 20' must be designed by an Engineer and submitted to the Physical Planning Division;
- Retrofitting from timber roof to concrete requires separate approval by the Physical Planning Division;
- Keep in mind that Dominica is also a HIGH SEISMIC RISK AREA for earthquakes as well as risk from hurricanes and volcanoes.

# NOTES

---





*Empowered lives.  
Resilient nations.*

