

Rehabilitation project in Panay and construction of a student dormitory, Cuartero and Tapaz, Panay Island, Philippines.

PCDR (Panay Center for Disaster Response)
in partnership with Caritas Luxembourg

2015-2017

DRR – Shelter Resilience Training kit



Acknowledgement

Special thanks for their contributions to the DRR training kit:

- DSAC: the carpenters and foremen of Libacao and Kalibo participating in the project and the engineer Lemuel A. Lachica,
- PCDR: the carpenters and foremen of Cuartero participating in the project, and the technical lead Christopher Limos,
- CRAterre: Annalisa Caimi, Elsa Cauderay, Florie Dejeant and Olivier Moles.
- Caritas Belgium, Caritas France and Caritas Luxembourg for their financial support.

Credits photo: unless otherwise specified all photographs illustrating this guide are credited to CRAterre and particularly to Annalisa Caimi, Elsa Cauderay, Florie Dejeant and Olivier Moles.

Picture first page: PCDR project: Pilot house in Cuartero, Capiz.

About this guide

This “disaster risk reduction (DRR) for shelter - training kit” aims at being a tool in the field of the building and DRR sector. It can actually be used in the framework of DRR campaigns, protection of local resources’ campaigns and for rural housing improvement, repairs and new construction activities or projects.

It was built up during two reconstruction projects in the aftermath of the super typhoon Haiyan and was designed along with a technical guide. Both projects were set up in Panay Island in the Philippines:

1. *Shelter and livelihood improvement project for the indigenous communities of Aklan. Project in partnership with the DSAC of Kalibo, SC/CF (Secours Catholique Français) and Caritas Belgium, 2014-2017.*
2. *Technical assistance to the Caritas Luxembourg / PCDR (Panay Centre for Disaster Response) rehabilitation project in Panay and construction of a student dormitory in Tapaz, 2015-2017.*

The training kit is designed to be used by trainers trained to this specific activity with various backgrounds, either with social or technical profile: engineer, architect, technician, community mobilizer, people organization (PO), etc. *Note that a training of trainers’ pedagogical guide has been also built up through those projects.*

The main objectives of the DRR shelter training is to:

- Raise awareness on the potential of local architecture (M1)
- Raise awareness on the interest of protecting local resources (M2)
- Develop DRR knowledge on how to improve sturdiness of the buildings by simple and economic ways (M3)

Structure of the training guide

The DRR Shelter - Training kit includes:

- “picture sheets” that are the one to be shown to the participants;
- “text sheets” that are a support for the trainers to guide the discussions.

Please note:

- This training kit has been designed for the specific context of the Municipalities of Cuartero (Capiz) and Libacao (Aklan) in Panay Island in the Philippines, even if it includes some messages and principles that are replicable in other parts of the country. Therefore, in order to reach properly the training’s objective, those messages and technical principles should be revised and adapted to any specific context where the awareness campaign will be disseminated.
- If you are stranger to the approach promoted in this guide and are interested in it, this guide may not provide you with all the necessary information. In this case, get closer to the people and organizations that fully master the concepts proposed, so that they can advise you usefully.

TRAINING CURRICULUM

Module Session	Methodology	Contents	Dur..
M0. INTRODUCTION			15mn
M0.1. Introduction & Round table	Round table		
M0.2. Presentation of the training and objectives	Presentation		
M1. RESILIENCE & POTENTIAL OF LOCAL ARCHITECTURE			45mn
M1.1. Concept of local building cultures	Discussion with pictures	Pictures of Filipinos and worldwide traditional buildings, to create interest and support discussion around the concept of local building cultures	
M1.2. Principle of resilience in housing	Discussion with pictures	Comparison of the resilience of a traditional "light material" building and a concrete building	
M1.3. Coping strategies	Case studies	Discussion through examples of coping mechanisms in shelter known by participants and proposed by the trainer	
M2. RELEVANCE OF LOCAL MATERIALS			1h
M2.1. Local materials: Introduction	Debate / Pictures	Introduction on the criteria that lead to choose a material or another for house construction	
M2.2. Walling materials	Debate / Pictures	Questioning on the different solution of walling. The advantages and disadvantages. Comparison between bamboo and plywood walling	
M2.3. Roofing materials	Debate / Pictures	Debate Ambulang/CGI Sheet for the roof. Advantages and disadvantages.	
M2.4. Foundation materials	Debate / Pictures	Wooden pillars / Wood quality and availability / Other solutions	
M2.5. Use & protection of local materials	Debate / Pictures	Focus on conservation and protection of wood and bamboo	
M3. HOW TO INCREASE STURDINESS OF BUILDINGS			1h30
M3.1. House exposition	Problem / Solution	P - Building exposed to wind S A - Tree barrier S B - Building orientation S C - Shape of the roof	
M3.2. Bracing	Problem / Solution	P - The house and/or the roof lies down S A - Bracing of the structure S B - Bracing of the roof	
M3.3. Connections	Problem / Solution	P - Some parts of the structure fall apart S - Good connection of structural components	
M3.4. Ties	Problem / Solution	P1 - Some parts of the structure are blown off S A - Tying-down from bottom up S B - Opening and crossed ventilation	
		P2 - Some part of the cover are blown off S A - Tying of roof covering S B - Stabilization system	
M3.5. Protection and maintenance	Problem/Solution	P - Some part of the house are rotten S1 - Drainage of the water S2 - Protection of the base of the post S3 - Maintenance	
M3.6. Conclusion	Examples	Examples of technical proposition	

M1 – RESILIENCE & POTENTIAL OF LOCAL ARCHITECTURE

TOPIC	Nb of pictures sheet	Nb of text sheet (for trainer)
1.1. CONCEPT OF LOCAL BUILDING CULTURES	6	1
1.2. PRINCIPLE OF RESILIENCE IN HOUSING	2	1
1.3. COPING STRATEGIES	3	1



House in suburbs of Manila, Philippines, 1899



Ivatan house in the Islands of Batanes in the very north of Philippines



Oyang, Province of Aklan, Panay Island, Philippines



Province of Aklan, Panay Island, Philippines



Oyang, Province of Aklan, Panay Island, Philippines

1.1 | TOPIC:

CONCEPT OF LOCAL BUILDING CULTURES

In other countries...



Yemen



Burkina Faso

1.1 | TOPIC:

CONCEPT OF LOCAL BUILDING CULTURES

In other countries...



France



Colombia

1.1 TOPIC: CONCEPT OF LOCAL BUILDING CULTURES

Those pictures were all taken in the Philippines
(except the two last pages to show apart)

WHAT ARE THE SELECTION CRITERIA OF THE OWNERS TO BUILD HIS HOUSE?

Example: protect from rain, elevated for floods, or storage, protect from warmth, temporary use, use of available materials (wood, stones, nipa, etc.), beauty, etc.

To classify through the followings:

Climatic conditions, natural risks, environment, available resources, functional needs, comfort, social needs, etc.

The history of construction shows that builders have always been able to evolve their habitat taking into account locally available resources to meet their needs, while adapting to social constraints, local climatic and natural risks.



Which house is the most *resilient*?



1.2 | TOPIC:

PRINCIPLE OF RESILIENCE IN HOUSING



1.2 TOPIC: PRINCIPLE OF RESILIENCE IN HOUSING

WHAT MAKES LOCAL ARCHITECTURE RESILIENT?

Which house is the most **resilient**? (*first page*)

- Resistance / Flexibility (“absorption”)

“Intelligence of the reed and strength of the rock”

- Ability to recover - Easiness to repair

Some parts may be damaged but the capital is conserved.

The materials can be reused. The skills are available.

*Definition of **resilience**: The ability of a system, community or society exposed to hazards **to resist, absorb, accommodate to and recover from** the effects of a hazard in a **timely and efficient manner**, including through the preservation and restoration of its essential basic structures and functions.*





1.4 | TOPIC: COPING STRATEGIES



transitional house



RECOVERY STRATEGY



permanent house

1.3 TOPIC: COPING STRATEGIES

WHAT PEOPLE DO WHEN THEY LEARN A TYPHOON IS COMING?

WHAT DO THEY DO AFTER THE TYPHOON?
(ask before showing the pictures)

Do you know some coping strategies when facing some disaster?

Examples of coping strategies before a typhoon (*page 1&2*):

- House moved and fully carried just before the typhoon
- Temporary tepee built in a safe place
- Temporary bracings/propping put outside to strengthen the house

Examples of coping strategies after the typhoon (*page 3*):

- Temporary tepee used as emergency shelter
- Transitional shelter made out of debris and salvaged materials (wall panels, lumber pieces, CGI sheets, etc.), using the remaining structure of the damaged house
- Permanent reconstruction using the remaining of the old house, if possible, salvaged and new materials.

M2 – RELEVANCE OF LOCAL MATERIALS

TOPIC	Nb of pictures sheet	Nb of text sheet <i>(for trainer)</i>
2.1. LOCAL MATERIALS: INTRODUCTION	1	1
2.2. WALLING MATERIALS	1	1
2.3. ROOFING MATERIALS	1	1
2.4. FOUNDATION MATERIALS	1	1
2.5. USE & PROTECTION OF LOCAL MATERIALS	1	1

2.1 | TOPIC:

LOCAL MATERIALS – INTRODUCTION



2.1 TOPIC: LOCAL MATERIALS – INTRODUCTION

WHICH MATERIALS WE CAN USE TO BUILD A HOUSE?

Local materials: bamboo, wood, rattan, nipa, ambulang, cogon, stone, sand

Other imported materials: ciment, plywood, hardiflex, CGI sheet, steel bar, nails

WHAT IS YOUR (GENERAL) OPINION ABOUT THE USE OF LOCAL MATERIALS AND IMPORTED MATERIALS?

WHAT WE NEED TO THINK ABOUT TO CHOOSE A MATERIAL OR ANOTHER?

Economic
Availability
Resistance
Durability
Comfort
Aesthetic
Know-how
Sustainability
Local economy



2.2 TOPIC: WALLING MATERIALS

WHAT ARE THE DIFFERENT SOLUTIONS OF WALLING WE CAN USE?

Bamboo (slices or open bamboo)
Amakan
Wood plank
Plywood
Hardiflex
Thatched walling (nipa/ambulang)

WHAT ARE THE DIFFERENT ADVANTAGES AND DISADVANTAGES / STRENGTHS AND WEAKNESSES OF EACH SOLUTION?

→ Comparison between bamboo and plywood walling

Economic
Availability
Resistance
Durability
Comfort
Aesthetic
Know-how
Sustainability
Local economy



2.3 TOPIC: ROOFING MATERIALS

WHAT ARE THE DIFFERENT SOLUTIONS OF COVERING WE CAN USE?

Nipa / Ambulang
CGI Sheet

WHAT ARE THE DIFFERENT ADVANTAGES AND DISADVANTAGES / STRENGTHS AND WEAKNESSES OF EACH SOLUTION?

Economic
Availability
Resistance
Durability
Comfort
Aesthetic
Know-how
Sustainability
Local economy



2.4 TOPIC: PILARS & FOUNDATIONS MATERIALS

WHAT ARE THE DIFFERENT SOLUTIONS OF FOUNDATION WE CAN USE?

Wooden pillars

Other possible solutions? *Concrete foundations (in place or prefabricated) ; stone under the pillar*

WHAT ARE THE ADVANTAGES AND DISADVANTAGES / STRENGTHS AND WEAKNESSES OF EACH SOLUTION?

Wooden pillars

- Which wood can be used?
- Raise the problem of quality and availability
- Possibility to replace the base of the pillars when rotten (need maintenance and know-how)

Concrete foundations

- Interesting when no quality wood is available
- Need of know-how (concrete foundation itself and connection with upper structure)
- Advantage of prefabricated foundations...



2.5 TOPIC: USE & PROTECTION OF LOCAL MATERIALS

WHY PROTECTING LOCAL MATERIALS?

To ensure a better condition/durability of the house

WHAT ARE THE SOLUTION / TECHNIQUES FOR A BETTER CONSERVATION / DURABILITY OF LOCAL MATERIALS?

Focus on solution for wood and bamboo (problem of humidity and insect attacks)

- Period of harvest
- Storage solution
- Drying solution
- **Protection solution**

People use to know solutions, let them talk about them...

Kind of recommendation for bamboo:

Don't let bamboos and wood under direct sun. They will dry too fast and crack. This will reduce their strength.

When you cut bamboos, keep them in running water for about 2 weeks and then let them dry in the shade.

This will reduce the risk of insect attacks.

M3 – HOW TO INCREASE THE STURDINESS OF THE HOUSE

TOPIC	MAIN PROBLEM	POSSIBLE SOLUTIONS
3.1. HOUSE EXPOSITION	House exposed to wind	A. Tree barrier
		B. Building orientation
		C. Shape of the roof
3.2. BRACING	The house and/or the roof lies down	A. Bracing of the structure
		B. Bracing of the roof
3.3. CONNECTIONS	Some parts of the structure fall apart	A. Good connection of structural components
3.4. TIES	Some parts of the structure are blown off	A. Tying-down from bottom up
		B. Opening and crossed ventilation
		C. Tying of roof covering
		D. Stabilization system
3.5. PROTECTION & MAINTENANCE	Materials are rotten	A. Drainage of the water
		B. Clean surroundings and landscaping
		C. Protection of the base of the posts
		D. Maintenance
3.6. CONCLUSION – EXAMPLES OF PROPOSITION		

 PROBLEMS

 SOLUTIONS

3.1 | PROBLEM:

THE HOUSE IS EXPOSED TO WIND

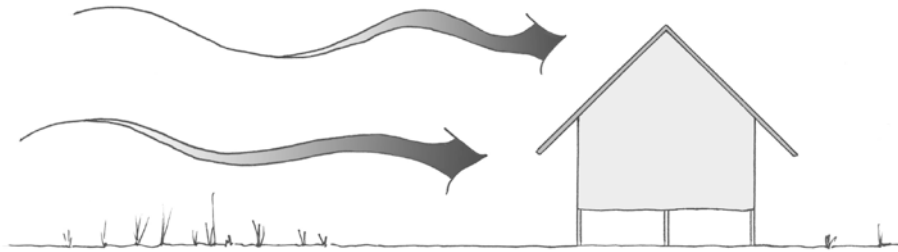

3.1 TOPIC: HOUSE EXPOSITION

PROBLEM: THE HOUSE IS DIRECTLY EXPOSED TO THE WIND

WHY IS THIS A PROBLEM?

The wind hits the house with all its force.

This can cause damages to the house.

WHY DOES THE WIND DIRECTLY STRIKE THE HOUSE?

There is no protection around the building.

3.1 | SOLUTION A: TREE BARRIER



3.1 TOPIC: HOUSE EXPOSITION

SOLUTION A: THE HOUSE IS SURRENDED BY VEGETATION

HOW CAN THE HOUSE BE PROTECTED FROM DIRECT WIND?

Let some trees and medium vegetation around the house.
They will reduce the speed of the wind.

BUT:

High trees (such as palm trees) can break under wind forces so flexible trees (such as bamboo, banana trees) should be preferred near the house.

Trees should be kept to some distance to avoid damages to the house if trees break down under wind forces

3.1 | SOLUTION B: BUILDING ORIENTATION

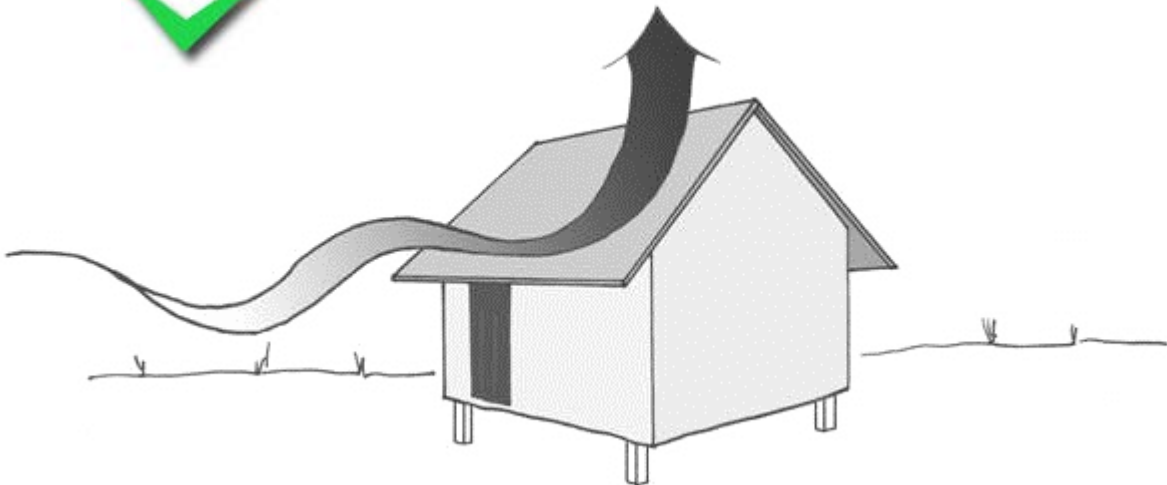
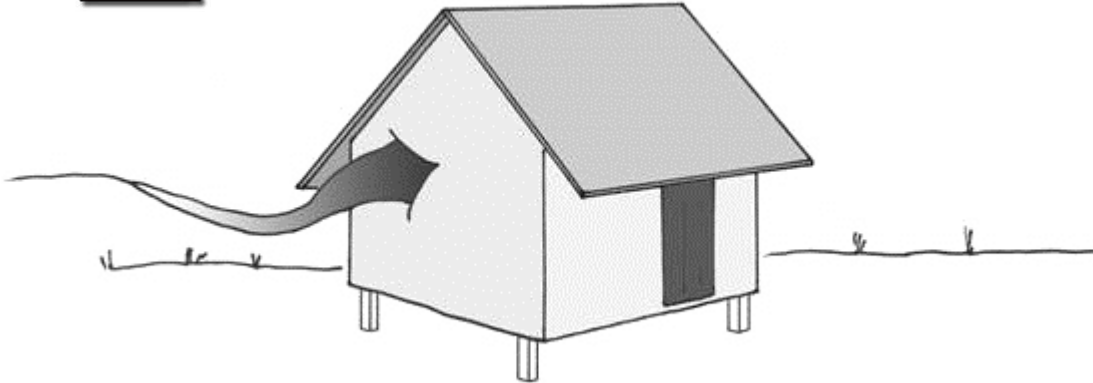

3.1 TOPIC: HOUSE EXPOSITION

SOLUTION B: THE HOUSE IS ORIENTED PERPENDICULAR TO WIND

HOW CAN THE HOUSE BE PROTECTED FROM DIRECT WIND?

If the roof has 2 slopes, it should be oriented perpendicularly to the main direction of the wind.

In this way the wind will easily pass over the house reducing risks of damages and roof up lift.

3.1 | SOLUTION C: SHAPE OF THE ROOF

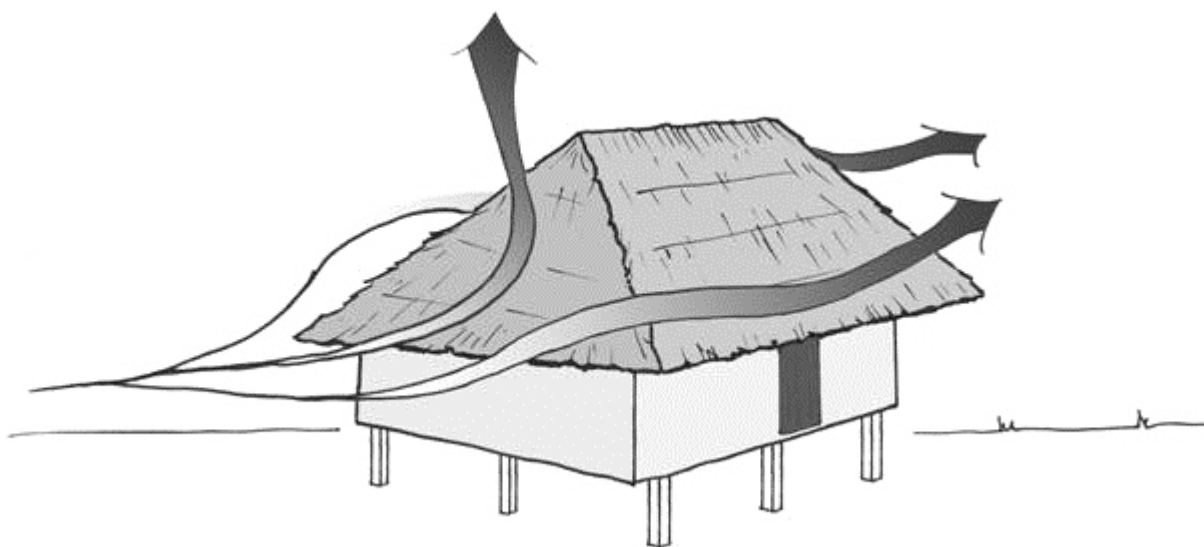

3.1 TOPIC: HOUSE EXPOSITION

SOLUTION C: THE WIND CAN EASILY PASS OVER THE ROOF

HOW CAN THE HOUSE BE PROTECTED FROM DIRECT WIND?

The best shape of the roof is 4 slopes, especially for CGI sheet covering.

In this way the wind can easily pass over the house from every direction, reducing risks of damages and roof up lift.

3.2 | PROBLEM:

THE HOUSE AND/OR THE ROOF LIES DOWN



3.2 TOPIC: BRACING

PROBLEM: THE HOUSE AND/OR THE ROOF LEANS OUTWARDS

WHY IS THIS A PROBLEM?

The house is unstable and it can collapse.

People inside the house are unsafe.

WHY DOES THE HOUSE LEAN OUTWARDS?

The structure of the house is not strong enough and it can fall down if no bamboos are used to keep it in place.

The structure is not stiff enough, and in case of strong winds, the house and/or the roof can tilt, slide or rotate and even fall down.

3.2 | SOLUTION A: BRACING OF THE STRUCTURE



3.2 TOPIC: BRACING

SOLUTION A: THE HOUSE IS STRENGTHENED WITH BRACING

Before showing pictures, draw a house on the chart/board and ask the participants to draw the bracings

HOW CAN THE ROOF BE STRENGTHEN?

Put bracing in every corner of the house.

They will ensure a good stability of the house and they will strengthen the structure against wind forces.

Bracing can be in wood or bamboo. They can be put diagonally, following a cross shape or only put at corner. The corner bracing uses small pieces of wood (such as off-cuts of lumber) and is a simple and economic solution, which can be used to reinforce an existing house.

Bracing should be placed horizontally and vertically. This will ensure strength in all directions. The posts (under the floor, if high enough), the walls, the floor and the ceiling should be braced.

Proper connections are very important (embedded or notched joints, not only nails)

3.2 | SOLUTION B:

BRACING OF THE ROOF STRUCTURE

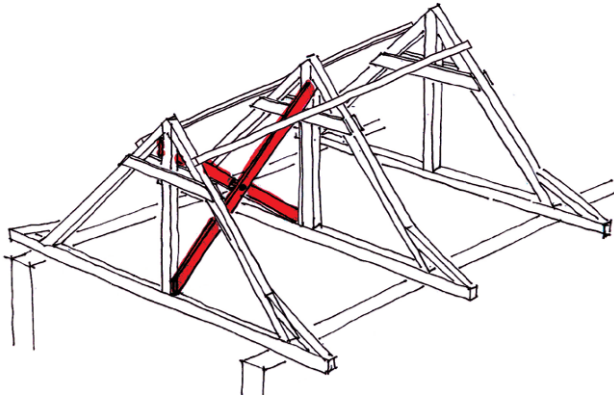

3.2 TOPIC: BRACING

SOLUTION B: THE ROOF IS REINFORCED WITH BRACING

HOW CAN THE ROOF BE STRENGTHENED?

Brace the roof properly to provide stability and strengthen its structure against wind forces.

If the roof uses a **ridge beam**, diagonal bracings can be put between the ridge beam and the posts (adding posts may be necessary). Diagonal or cross bracings can also be laid in an inclined position between rafters.

If the roof is made out of a **truss system**, with no ridge beam, then cross bracing should be added between the trusses.

3.3 | PROBLEM:

**CONNECTIONS ARE WEAK
PARTS OF THE STRUCTURE CAN FALL APART**



3.3 TOPIC: CONNECTIONS

PROBLEM: THE CONNECTIONS OF THE STRUCTURE ARE WEAK

WHY IS THIS A PROBLEM?

The components of the structure are not well tied together.

The house can fall apart and it can be damaged by the wind.

People inside the house are unsafe.

WHY ARE THE CONNECTIONS WEAK?

The joints are not properly done.

The materials used to tie are not strong enough or they are rotten.

3.3 | SOLUTION: GOOD CONNECTION OF STRUCTURAL COMPONENTS



3.3 TOPIC: CONNECTIONS

SOLUTION THE PARTS OF THE STRUCTURE ARE WELL CONNECTED TO EACH OTHERS

HOW CAN THE STRUCTURE BE IMPROVED TO BETTER WITHSTAND WIND FORCES?

Use good joints to connect the components of the structure.

They will improve the stability of the structure and reduce the risk of damages.

It particular, a connection should not rely only on nails and a good joint consists in:

- A proper detail of connection (embedded, half or notched joint)
- An appropriate fixation (nails, pegs, screw, bolts)
- A good tying system (rattan, metal strapping, galvanised tie wire).

3.4 | PROBLEM 1:

SOME PARTS OF THE HOUSE ARE BLOWN AWAY

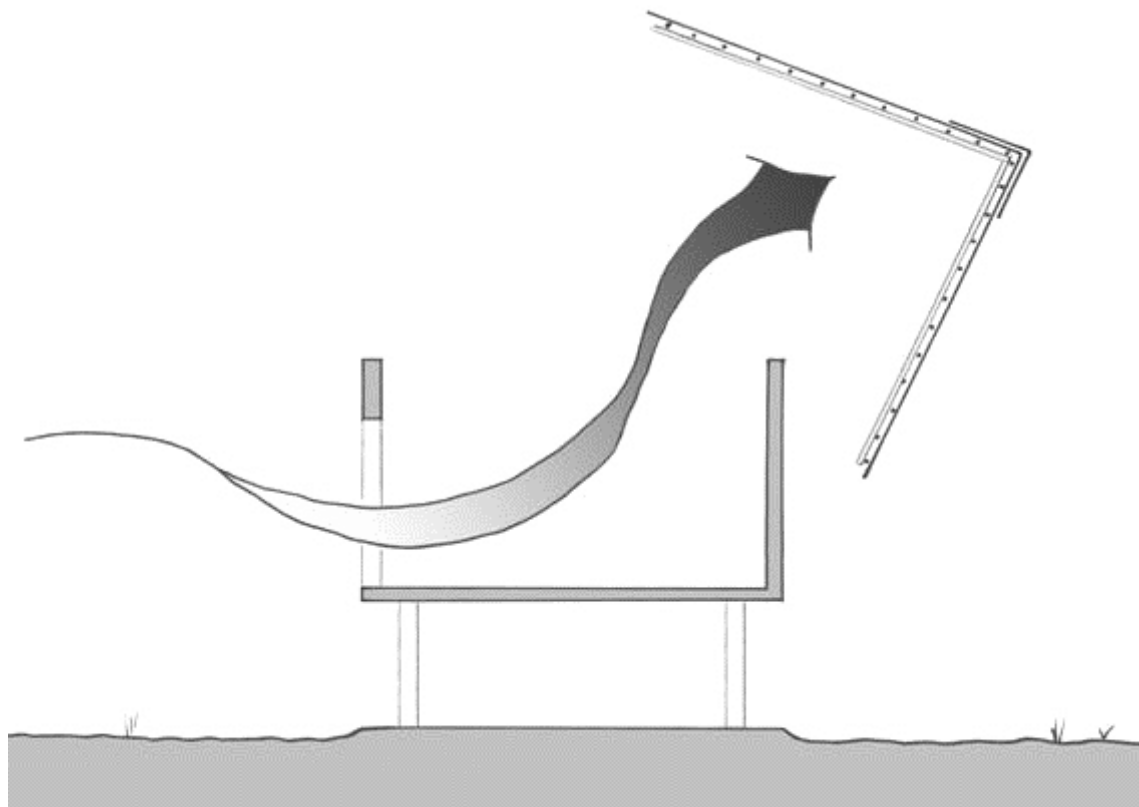

3.4 TOPIC: TIES

PROBLEM 1: SOME PARTS OF THE HOUSE ARE BLOWN AWAY

Usually the roof is the part to be blown off

WHY IS THIS A PROBLEM?

There is no more protection from rain and sun.

The people inside the house are unsafe.

WHY IS SOME PART OF THE HOUSE BLOWN OFF?

The different part of the house are not well tied together

The wind goes inside the house but it cannot go out.

3.4 | SOLUTION A: TYING EACH PART OF THE STRUCTURE TOGETHER



3.4 TOPIC: TIES

SOLUTION A: THE PARTS OF THE STRUCTURE ARE WELL TIED TO EACH OTHERS

HOW CAN THE STRUCTURE BE IMPROVED TO BETTER WITHSTAND WIND FORCES?

Connect the components of the structure together with good ties and quality materials:

- rattan, rope or galvanized iron wire (multiple layer);
- timber cleats;
- galvanized metal strap.

They will work against the wind suction and keep the parts of the structure together, reducing the risk of damages.

As a simple and economic way to reinforce an existing house, any leftover or recycled material such as electric wires, small pieces of CGI sheets, bamboo's "skin", leftover lumber, can be used to tie different components of the structure.

3.4 | SOLUTION B:

THE WIND CAN PASS THROUGH THE HOUSE

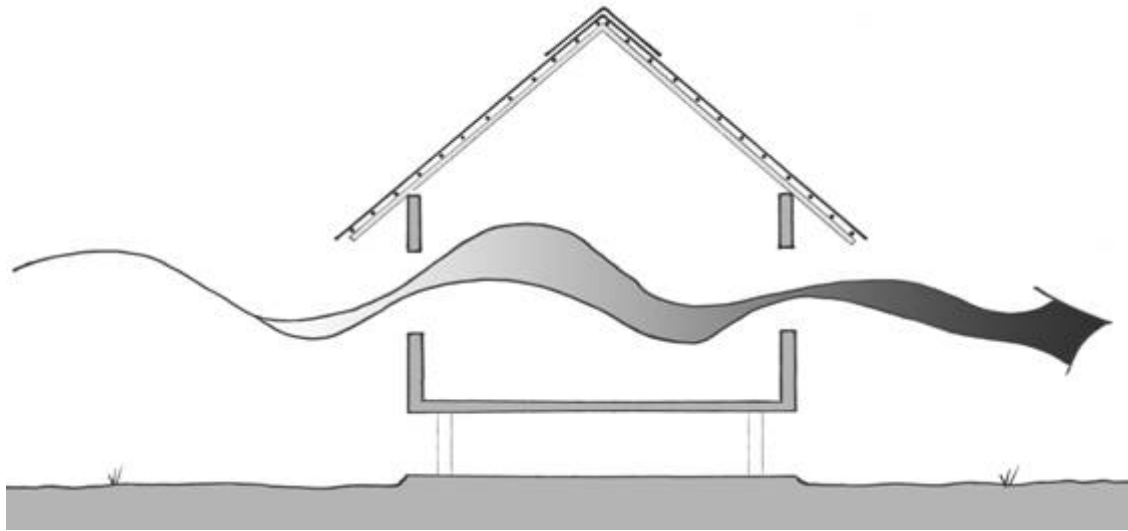

3.4 TOPIC: TIES

SOLUTION B: THE WIND CAN PASS THROUGH THE HOUSE

HOW CAN THE STRUCTURE BE IMPROVED TO BETTER WITHSTAND WIND FORCES?

Use openings to let the wind go out from the house.

This will reduce pressure on the roof and the risk of a suddenly blown off of the whole roof.

Match door and windows aligned on two opposite side of the room. This will help the wind to go out and it will improve better ventilation.

Windows with grid and small openings over doors and windows ensure air circulation and privacy.

Small openings under a roof with 2 slopes will let the wind go out from the house reducing its force on the roof.

3.4 | PROBLEM 2:

SOME PARTS OF THE COVER ARE BLOWN OFF



© CRATERRE



AFTER

3.4 TOPIC: TIES

PROBLEM 2: SOME PARTS OF THE COVER ARE BLOWN OFF BY THE WIND

WHY IS THIS A PROBLEM?

There is no more protection from rain and sun and the people inside the house are unsafe.

The structure of the house may be damaged by the wind and by the rain.

WHY IS THE ROOF BLOWN OFF?

The covering of the roof is not well tied to the roof structure.

The covering of the roof is not stable under the wind force.

3.4 | SOLUTION C:

APPROPRIATE TYING OF ROOF COVERING

Ambulang / Nipa roof

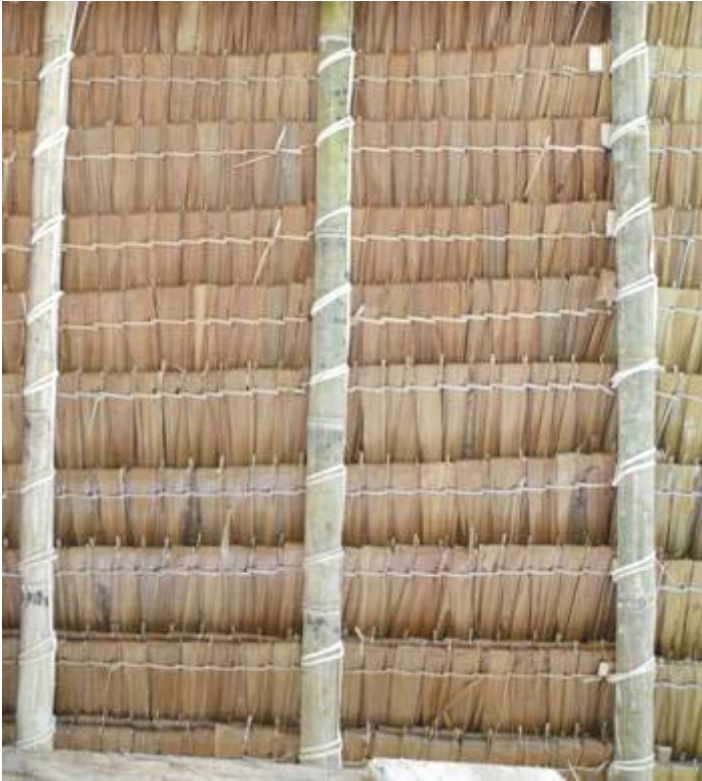

CGI Sheet roof



3.4 TOPIC: TIES

SOLUTION A: THE ROOF COVERING IS WELL FIXED TO THE ROOF STRUCTURE

HOW CAN THE STABILITY OF AMBULANG ROOF BE IMPROVED?

Ambulang / Nipa:

Tie ambulang to bamboo battens every 15 inches with good rattan ropes.

Ambulang overlap should be about 4 inches.

In the lower and upper part of the roof, use a double layer of ambulang.

This will reduce the risk of blown off and will ensure a better protection from water penetration.

CGI Sheets:

CGI sheets should be overlapped at least:

2 corrugations on lateral direction

6 inches on vertical direction

Use screw or umbrella nails to fix CGI sheets to purlins.

Normal nails can be easily pulled out under wind force.

Consider the main wind direction to decide of the direction to lay the CGI sheets (start at the opposite side from where comes the main wind).

Use fascia boards on the eaves and overhangs to reduce lift up by the wind.

Regularly replace damaged parts and ties.

3.4 | SOLUTION D: STABILIZATION SYSTEMS



3.4 TOPIC: TIES

SOLUTION B: STABILIZATION OF THE ROOF COVERING

HOW CAN THE STABILITY OF THE ROOF COVERING BE IMPROVED?

Put a grid or bamboos over the roof and tie them to the roof structure. This will prevent roof covering to flying away and will reduce damages.

For ambulang and nipa roof:

- put a grid with about 1 feet spacing over the roof
- on the eaves, use half bamboo connected to purlins to improve the stability of ambulang the side of the roof

For CGI sheet roof:

- put some bamboos tied to each other over the roof
- bamboos should be placed:
 - o on the hip and in the middle of each roof slope
 - o horizontally at upper lower and middle level of the roof

The roof structure can also be temporarily tied with some strong ropes to some trees nearby the house. This will ensure that the roof will not be completely blown off.

Some bracing against the structure can also be put temporarily to ensure a better stability of the house.

3.5 | PROBLEM:

MATERIALS ARE ROTTEN



3.5 TOPIC: PROTECTION AND MAINTENANCE

PROBLEM: SOME PARTS OF THE HOUSE ARE ROTTEN

WHY IS THIS A PROBLEM?

They are no more able to ensure the good strength of the construction.

The structure of the house is weak and it can be damaged by the wind.

WHY ARE THE MATERIALS OF THE HOUSE ROTTEN?

When it rains, there is a lot of water around the house.

The bottom part of the posts are affected by moisture and damaged by humidity. They are not more able to ensure good stability.

Some parts of the house are eaten by insects and exposed to rain.

3.5 | SOLUTION A: DRAINAGE OF THE WATER

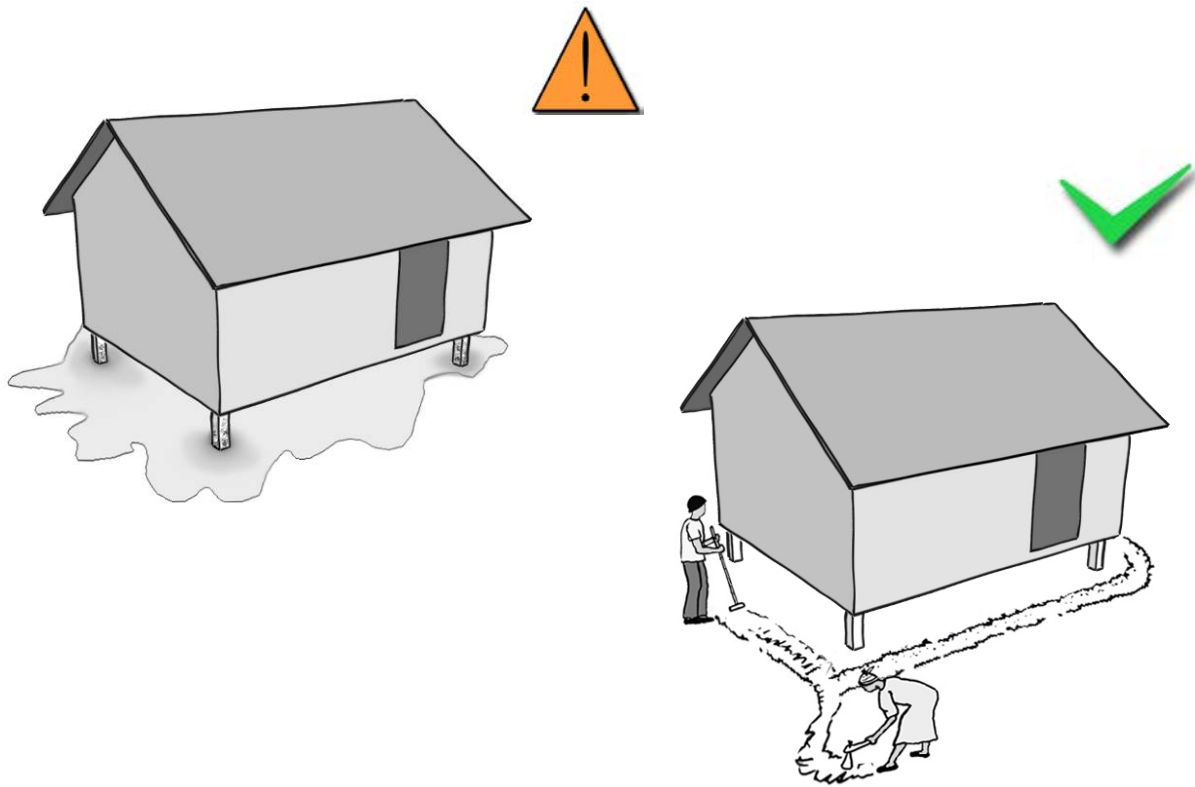

3.5 TOPIC: PROTECTION AND MAINTENANCE

SOLUTION A: RAIN WATER IS DRAINED OUT FROM AROUND THE HOUSE

HOW CAN THE RAIN WATER BE DISCHARGED?

Dig a drainage trench all around the house, where the rain water falls from the roof and under the sink of the kitchen.

Connect it to a trench going far from the house (for example in the fields or to the river). This will drain the water away from the house and will avoid big flags.

Drainage trenches should have a small slope so that the water can go away.

Fill the trenches with small stones. This will protect from the erosion of the trench sides by the water.

3.5 | SOLUTION B:

CLEAN SURROUNDINGS AND LANDSCAPING

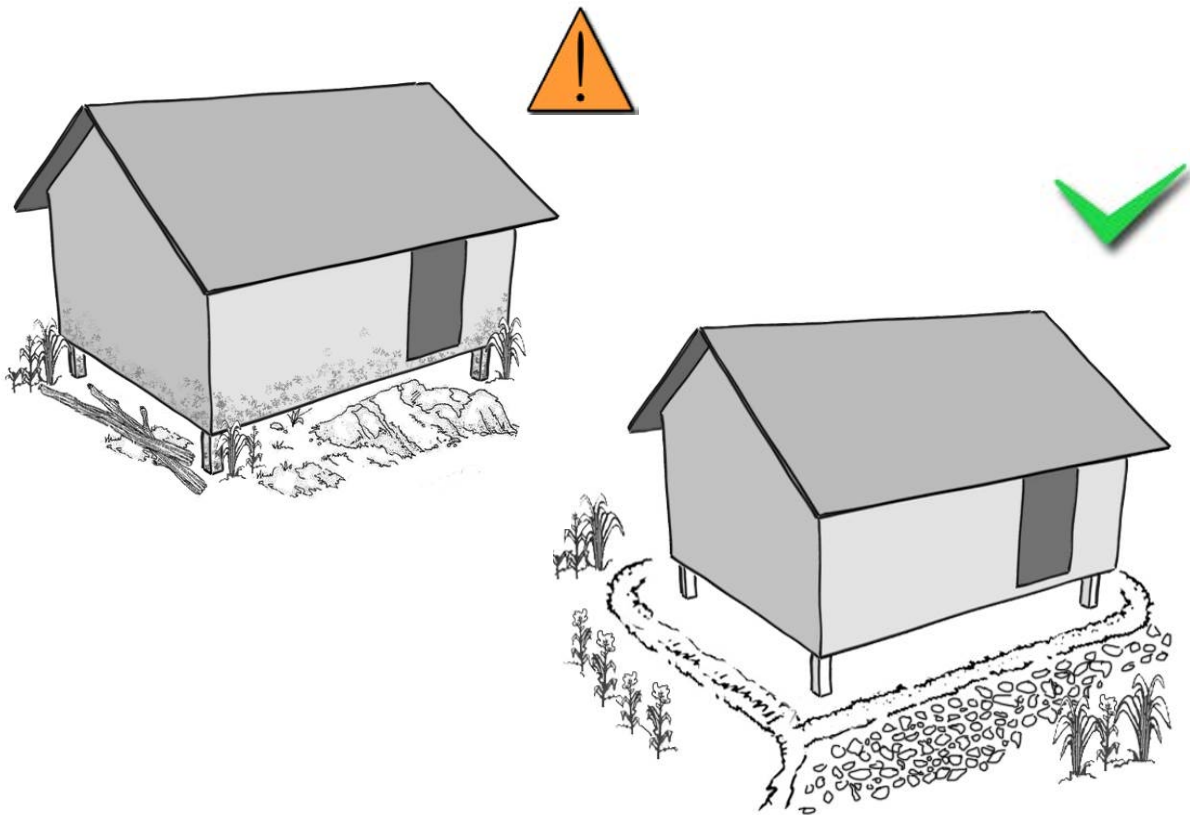

3.5 TOPIC: PROTECTION AND MAINTENANCE

SOLUTION B: THE HOUSE IS KEPT SAFE FROM MOISTURE RETENTION

HOW CAN THE HOUSE BE KEPT DRY?

Properly maintain the surroundings of the house.

The direct surroundings of the buildings should be cleaned regularly from vegetation, various stocks of materials and objects as it will retain moisture around the building and the wooden pillars.

Check if there are no pools that can accumulate water, especially under and close to the buildings and pillars. In case of uneven soil, level the soil by filling the pools and compact it and by excavating higher soil.

In order to prevent the soil erosion, the ground can be stabilized with solutions that will reduce the water flow velocity, for example, using gravels, rocks and/or appropriate plants. This will serve also to embellish the site and eventually to delineate some spaces or limits.

3.5 | SOLUTION C:

PROTECTION OF THE BASE OF THE POSTS



3.5 TOPIC: PROTECTION AND MAINTENANCE

SOLUTION C: THE BASE OF THE POSTS IS PROTECTED FROM WATER

HOW CAN THE POSTS BE PROTECTED FROM WATER?

Use foundations to connect the posts with the ground. They will avoid that timber and bamboo posts are directly in contact with the ground and the water inside it. This will ensure a long lasting of the posts and a good stability of the house.

For main posts, foundations may be done with a concrete foot under each post.

A cheaper solution is to use a piece of wood embedded into the ground and connected to the post with a joint. If damaged, it can be easily replaced keeping the post in place.

Do not cover the post with cement or plastic sheet and do not inlay the post into the foundation.

For small posts bearing the floor, put a stone under them. This will ensure a longer lasting.

Foundations should ensure a good anchorage of the house to the ground.

3.5 | SOLUTION D: MAINTENANCE OF THE HOUSE



3.5 TOPIC: PROTECTION AND MAINTENANCE

SOLUTION D: MAINTENANCE - THE COMPONENTS OF THE STRUCTURE ARE IN GOOD CONDITION

HOW CAN THE GOOD CONDITION OF THE HOUSE BE ENSURED?

Regularly **replace** damaged parts and ties, especially before the typhoon season.

This will reduce the risk of damages and will ensure the strength of the house.

Which part especially?

- Roofing
- Walling
- Pillars





BEFORE



AFTER

3.6 TOPIC: CONCLUSION – EXAMPLE OF PROPOSITION

The solutions proposed here are adapted to a specific context and in the framework of a specific project regarding the technical capacities, the availability of materials, the economical capacities, the disaster risks, etc.

- 1st page: New house - Province of Aklan, DSAC Kalibo
- 2nd page: Reinforced house – Province of Capiz, PCDR

Ask the participants to describe what solutions were proposed here (bracings, concrete foundation, ambulang cover, etc.)

Adapt eventually this topic to the proposition made in your project, by changing the pictures.