

# Rebuilding Water-Damaged Homes

A manual for the safe, healthy, green, and low-cost restoration of housing

September 2009



Produced by The Alliance for Healthy Homes

Primary Content & Illustrations Dennis Livingston

Design and Production Jennie Keinard &

Ruth Klotz-Chamberlin

Additional Content Ralph Scott

# Rebuilding Water-Damaged Homes

A manual for the safe, healthy, green, and  
low-cost restoration of housing

Produced by The Alliance for Healthy Homes



Primary Content & Illustrations Dennis Livingston  
Design and Production Jennie Keinard &  
Ruth Klotz-Chamberlin  
Additional Content Ralph Scott

For additional copies go to:  
[www.afhh.org/flooddamagedhomes.pdf](http://www.afhh.org/flooddamagedhomes.pdf)  
or  
[www.hud.gov/lead/healthyhomes](http://www.hud.gov/lead/healthyhomes)

---

# Acknowledgements

Earlier editions of this manual were written following Hurricanes Katrina and Rita as an instructor's guide for a train-the-trainer course on restoring flood-damaged homes that the authors developed and delivered eight times during 2006-7 in New Orleans and the Mississippi Gulf Coast to contractors, volunteers, representatives of government agencies and non-profit organizations, and trainers. We used the manual to teach a similar course in 2008 in Quincy, Illinois, in the aftermath of severe flooding of the Mississippi River. This version has been modified somewhat to address restoring water-damaged homes more generically.

We would like to thank several people and organizations that provided assistance, constructive criticism and other feedback that has immeasurably helped us develop and improve this manual. We deeply appreciate the thoughtful feedback and the network of excellent resource people that Audrey Evans (currently consulting for Catholic Charities' Operation Helping Hands) provided to us. We also want to thank David Reynolds (former director of the Green Project), Joseph Ponessa (Professor Emeritus, Rutgers Cooperative Extension), Colette Pichon Battle (Moving Forward Gulf Coast), Tracy Nelson (Director, Historic Building Recovery Grant Program, Louisiana State Historic Preservation Office), Tom Neltner (National Center for Healthy Housing), and Claudette Reichel (Louisiana State University AgCenter) for providing extensive and thoughtful suggestions. We are grateful to Scott McDonald for allowing us to use his house lifting strategy in the manual. We appreciate the valuable input we received from several New Orleans contractors, especially Paul Wabnig and Steve Wallman. And thanks to Terry Brennan and Joe Lstiburek for laying the foundation of the "home as a living system" approach.

We want to thank the Preservation Resource Center (PRC) of New Orleans for providing us with a laboratory for developing this manual, and we particularly thank Maryann Miller, Averil Oberhelman, Brian Cornelison, and Patty Gay of PRC for their hard work to assist us. We also thank the Mississippi Interfaith Disaster Task Force (MSIDTF), and we particularly thank Farlene Bowman, Cindy Lamb and Roberta Avila of MSIDTF for helping us reach critical audiences on the Mississippi Gulf Coast. Six other Gulf Coast organizations also deserve special mention for their support and assistance: Louisiana ACORN, Louisiana Environmental Action Network, Sierra Club – Delta Chapter, Physicians for Social Responsibility – Louisiana Chapter, Common Ground Relief, and the Holy Cross Neighborhood Association. We also thank Enterprise Community Partners, Chase Bank, and the Fannie Mae Foundation Fund at the Homebuilding Community Foundation for supporting the Alliance's work in this area. We are grateful to the National Center for Healthy Housing for its support and advice. Finally, we wish to thank the Office of Healthy Homes and Lead Hazard Control at the U.S. Department of Housing and Urban Development (HUD) for printing the manual in bulk and for their thoughtful feedback on content.

Others too numerous to name individually, including the dozens of people who participated in the interactive workshops delivered using these materials during the past year, also helped us refine this manual more than they probably realize. Thanks to you all! The Alliance for Healthy Homes is responsible for any errors and omissions and we would very much appreciate being told of any.

Several products (tools and materials) are mentioned by name in the manual, and an appendix includes information about their prices and how to obtain many of these products. Mention of these products does not imply an endorsement of them by HUD or the Alliance; they are merely provided for the convenience of practitioners as examples of products that can be used for the activities described in the manual. In many cases alternative products may also suffice.

# Introduction

---

This is a manual on safe, healthy, green, and affordable rebuilding of water-damaged homes that will:

- Serve as a workbook for seminars
- Be distributed to people working on their own homes, volunteers, and other workers as a guide and reference manual
- Develop work protocols for contractors

This manual will be reproduced in small quantities as it is periodically edited. The edited version will be continuously available at [www.afhh.org/flooddamagedhomes.pdf](http://www.afhh.org/flooddamagedhomes.pdf) by the Alliance for Healthy Homes and at [www.hud.gov/lead/healthyhomes](http://www.hud.gov/lead/healthyhomes) by HUD's Office of Healthy Homes and Lead Hazard Control.

The focus of the manual is pre-World War II, one- and two-story frame houses with wood siding but is applicable to a broader variety of homes. The manual emphasizes affordable strategies, making it most useful for low- and moderate-income communities.

The following are some of the manual's guiding principles:

- It seeks to describe the strategies with lowest up-front cost strategies except when life cycle cost calculations clearly lead one to a strategy that has greater initial cost.
- It emphasizes strategies that minimize energy and maintenance costs.
- It favors labor-intensive strategies that employ local workers over capital-intensive solutions.
- Preserving the history and culture of each community and its homes is a key consideration
- Most important, it seek to promote occupant and community health and safety.
- All design and work protocols decisions strive to maximize sustainability.
- All decisions should seek to build the long term capacity and economic independence of each community.

Throughout the manual, priority is given to saving as many original components of older homes as possible. Although historic preservation has value in itself, there are other reasons to save these building components. For example: how do issues of health, community economics, environment, and affordability help us decide whether to save an old wood window?

An 80-year-old double hung window on a counterweight system with failing paint can be restored and weather-stripped for about \$300. It also can be replaced with a new vinyl, double glazed window for about the same price.

1 Initial cost vs. long-term savings. Although the restoration of a double-hung wood window may cost more than a vinyl replacement window, restoration is a far more economical choice when life cycle cost is considered. An ordinary vinyl window that costs \$200 installed, will last about 15 years, even the best vinyl window costing \$300 installed will last no more than 25 years. A 75-year-old window made of old growth wood, maintained properly, will easily last another 100 years.

2 Supporting the local economy. While most of the money spent on a replacement window goes to manufacturers outside the community, virtually all the money spent for a window restoration goes directly to local trades people. Moreover, the skills involved in installing replacement windows are not useful in many other trades, but a worker who learns to restore wooden windows has gained a valuable skills that are transferable to other building and restoration work. A carpenter can learn to restore wooden windows at production speed in a week of training and on-the-job experience.

3 Environment and health considerations. Wood and glass are materials that cause no adverse health problems for workers or occupants. Windows made from these materials are biodegradable. Polyvinyl chloride (PVC) windows are extremely toxic for workers who produce them, they are an environmental hazard in a house fire, and they pollute the environment when they eventually enter the waste stream. A new National Academy study affirms the toxic and carcinogenic nature of PVC. (If window replacement is the strategy selected wood or fiberglass windows are a safer option). The major health risk associated with old windows is from lead paint. Making a window lead-safe is part of the restoration and abatement process and can be done safely. Installing a vinyl replacement window in the original jamb still leaves a significant amount of lead on the jamb, casing, sill, and stool.

4 Energy conservation. Energy cost savings typically don't justify window replacement. Two studies demonstrated that replacing a single-glazed, well weather-stripped, wooden window with a double-glazed vinyl replacement window did not result in enough savings, over the life of the window, to pay for itself.\* There are many ways to spend less money and realize greater energy savings. In this climate, sun control (shading, solar film, etc.) is most important for energy saving. Original wood windows can be reglazed with low E, laminated glass which is almost as energy efficient as double glazing, is wind resistant, shatter resistant, and can be easily replaced.

5 Maintenance costs. Almost any part of a broken, double hung wooden window can be easily repaired. A broken vinyl replacement window often must be replaced in its entirety. The chain and counterweight system of an old double-hung window will normally last more than 100 years, while the spring balance system of a vinyl replacement window may need to be replaced within a decade.

6 Preserving tradition and culture. While a new wood replica replacement for a damaged old-growth wood window may address aesthetic issues and satisfy historic preservation principles, the replica usually contains inferior wood that is far more subject to rot and insect damage than the original old growth wood window (particularly if the original window was cedar, which naturally repels insects). When replacement is necessary pressure treated wood windows are available.

\* - Energy Saving Leaflet 7: Framing Options. English Heritage: London, Sept. 1994.

- James, B, Shapiro, A. Retain or Retire? A Field Study of the Energy Impacts of Window Rehab Choices. Vermont Energy Investment Corporation: Vermont, Nov.1996.

# Table of Contents

---

1 Names of Building Parts	Page 9
Double hung wood window	
Panel door	
Wall trim and siding	
Plaster on lath	
Foundation structures	
Roof structure	
2 Plan for Clean-out Evaluation	Page 17
Check structural safety	
Evaluate damage to walls & ceilings	
Utility shut-off	
Clean-out health risks	
Work site organizing	
3 Clear-out	Page 25
Basic precautions	
Prepare for personal health and safety	
The completed clean-out site	
The clean-up, health & safety area	
A comfortable, shaded place to take a break	
Possession clean-up station	
Sort contents as you remove them	
Finishing clear-out	
Save what can be saved	
Plaster removal	
Cleaning work sequence	
Security system for windows & doors	
Entrance door security	
Some specialized tools	
Structural repairs	
4 Clean & Treat	Page 41
Cleaning	
Borate treatment	
5 Creating a Clean Room during Restoration	Page 45
The clean-room	
Isolating clean rooms	
Clean-room in a two story house	
Creating a poly flap seal	

6 Flood & Moisture Resistant Restoration	Page 51
Flood and wind resistance of foundations	
Flood resistant design	
Flood resistant kitchen storage	
7 The House As A System	Page 57
How water enters and moves through a house	
Shed, block, drain, dry	
Flashing	
Roof flashing	
Insulation strategies	
8 Green, Lead Safe Restoration	Page 65
Saving a plaster wall	
Plaster surface repair	
Lead safe window restoration	
Window safety	
Weather-stripping double hung windows	
Counter weight system repair	
Stripping of wood windows	
Bench top for sash gluing and epoxy	
Epoxy, repair, and restoration of wood windows	
Floor restoration	
9 Mechanical Systems	Page 79
Heating, cooling, and air-conditioning	
10 Storm Resistant Designs	Page 83
“Dead man” hurricane resistant tie-down	
Storm shutters	
11 House Lifting Strategy	Page 87
Appendix I Case Study: Critical Unresolved Questions	Page 93
Appendix II Community Rebuilding	Page 99
Appendix III Tools, Supplies, & Resources	Page 101



## Names of Building Parts

### Principles:

A common language shared by owners, workers, contractors, and suppliers avoids misunderstandings.

Unless there is a pressing structural or health reason, save the architectural elements of older houses because they usually work best, are least toxic, can be maintained more easily and will last longer.

# Double Hung Wood Window

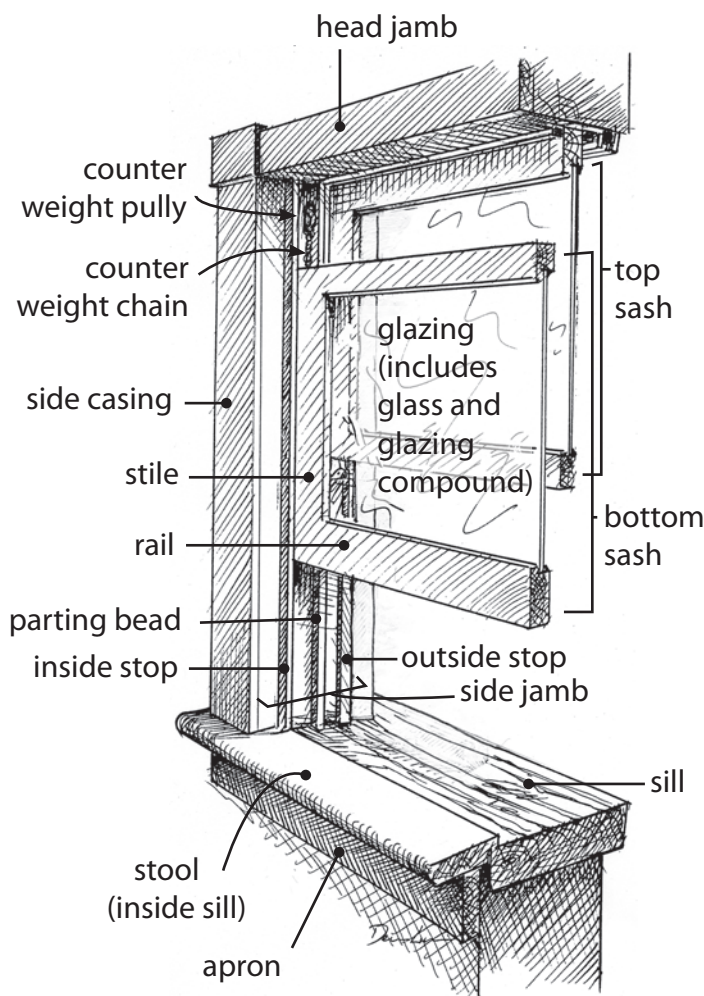

Seven reasons to restore double hung wood windows rather than replacing them with vinyl windows

1 They can be easily maintained. Sash can be easily reglazed. Small areas of wood deterioration can be repaired with epoxy systems and the joints re-pegged.

2 If well-maintained they can last 200 years. Windows made of old growth wood, particularly cedar, extend their life. No window balance system approaches the longevity of a chain and counterweight system.

3 They can be effectively weather stripped. A vinyl replacement window may never pay for itself in energy savings by the time it needs to be replaced in 10 to 20 years. This is particularly true for the Gulf Coast. (see footnote page 5) Original wood windows can be reglazed with low E, laminated glass which is almost as energy efficient as double glazing, is wind resistant, shatter resistant, and can be easily replaced.

4 Polyvinyl chloride, which contains dioxin, is a carcinogen and causes birth defects and developmental problems when released into the environment.

5 The maintenance of existing building components is the greenest, most sustainable protocol.

6 The restoration of windows is a labor-intensive opportunity for local employment.

7 Original windows maintain important historic fabric.

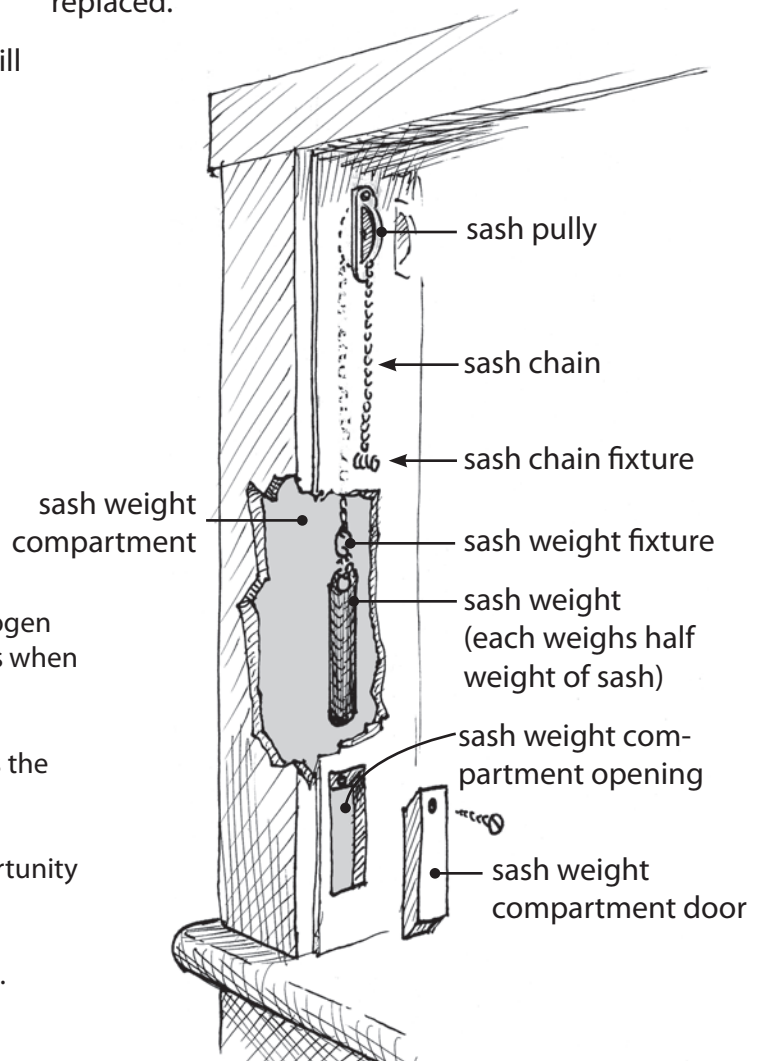

# Panel Door

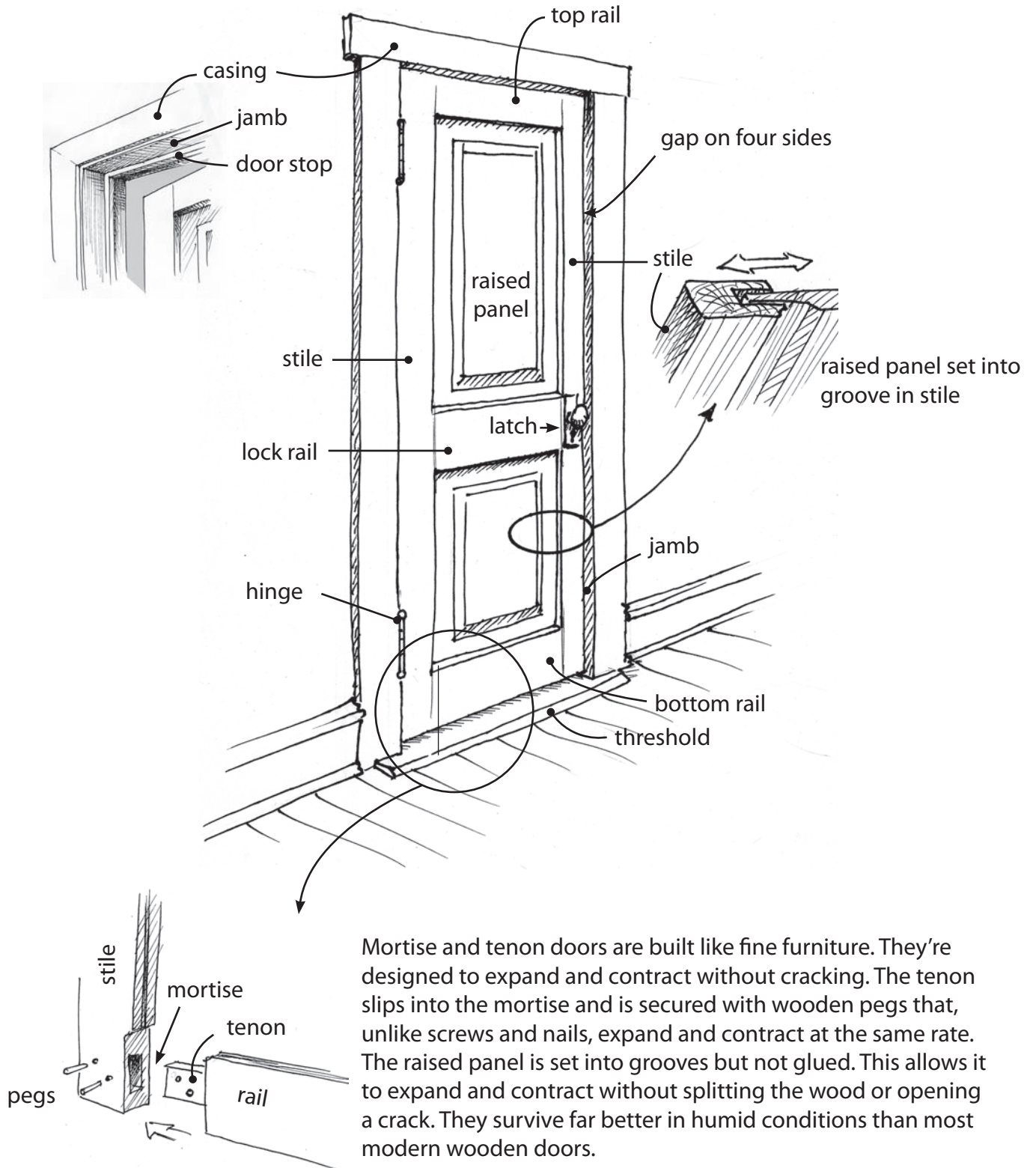

Mortise and tenon doors are built like fine furniture. They're designed to expand and contract without cracking. The tenon slips into the mortise and is secured with wooden pegs that, unlike screws and nails, expand and contract at the same rate. The raised panel is set into grooves but not glued. This allows it to expand and contract without splitting the wood or opening a crack. They survive far better in humid conditions than most modern wooden doors.

# Wall Trim and Siding

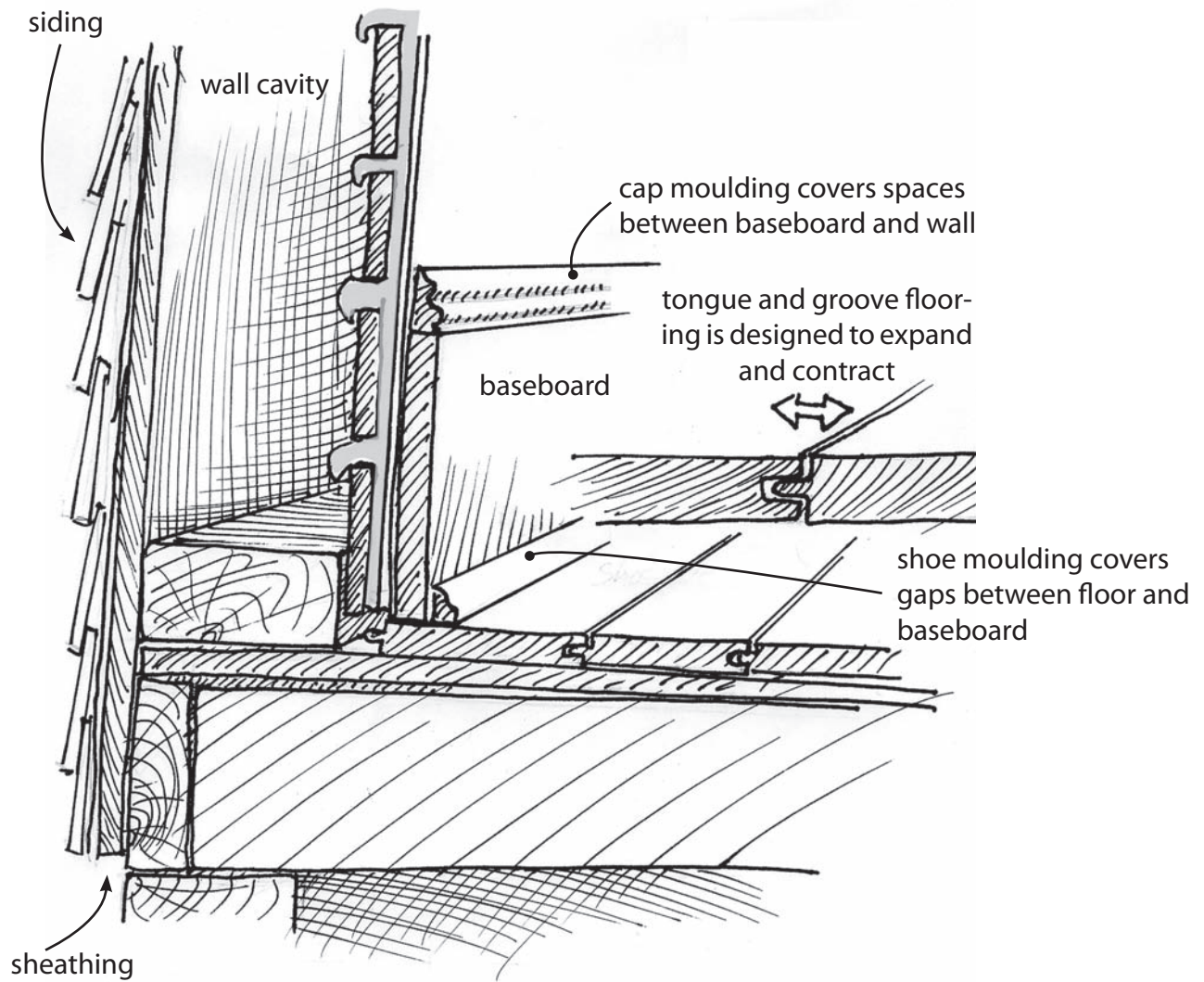

# Plaster on Lath

Whenever possible save plaster. If maintained, it will last hundreds of years. It's resistant to mold and cockroaches and easily repaired. Drywall, on the other hand, contains paper, provides food for mold and cockroaches, suffers irreversible damage when it becomes wet, has a short life span, and is difficult to repair. When putting up new walls -- if you cannot use plaster -- use paperless drywall with a moisture resistant core.

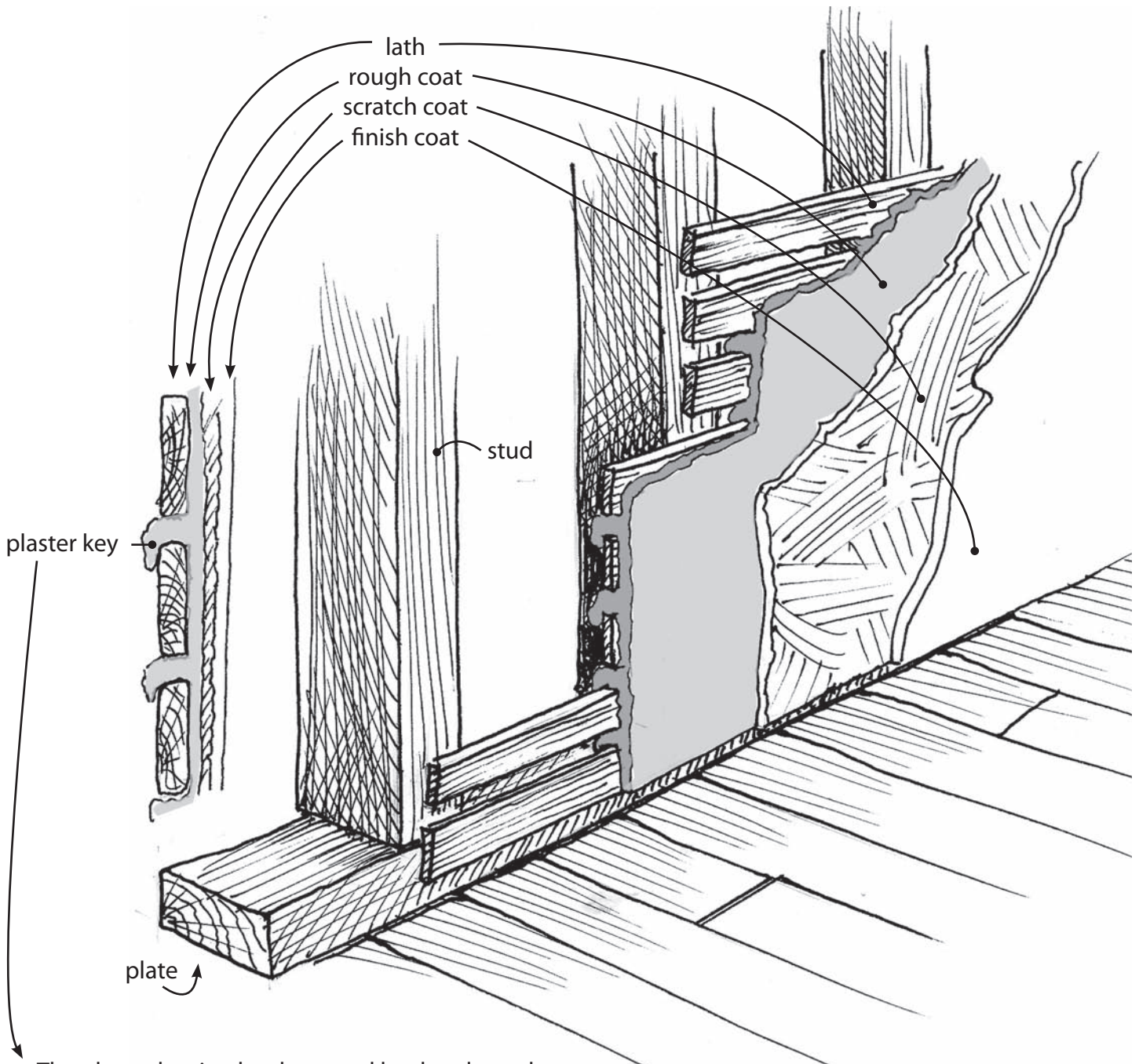

The plaster key is a hook created by the plaster being forced between the lath and drooping down. If many of these break off, the plaster may separate from the lath.

# Foundation Structures

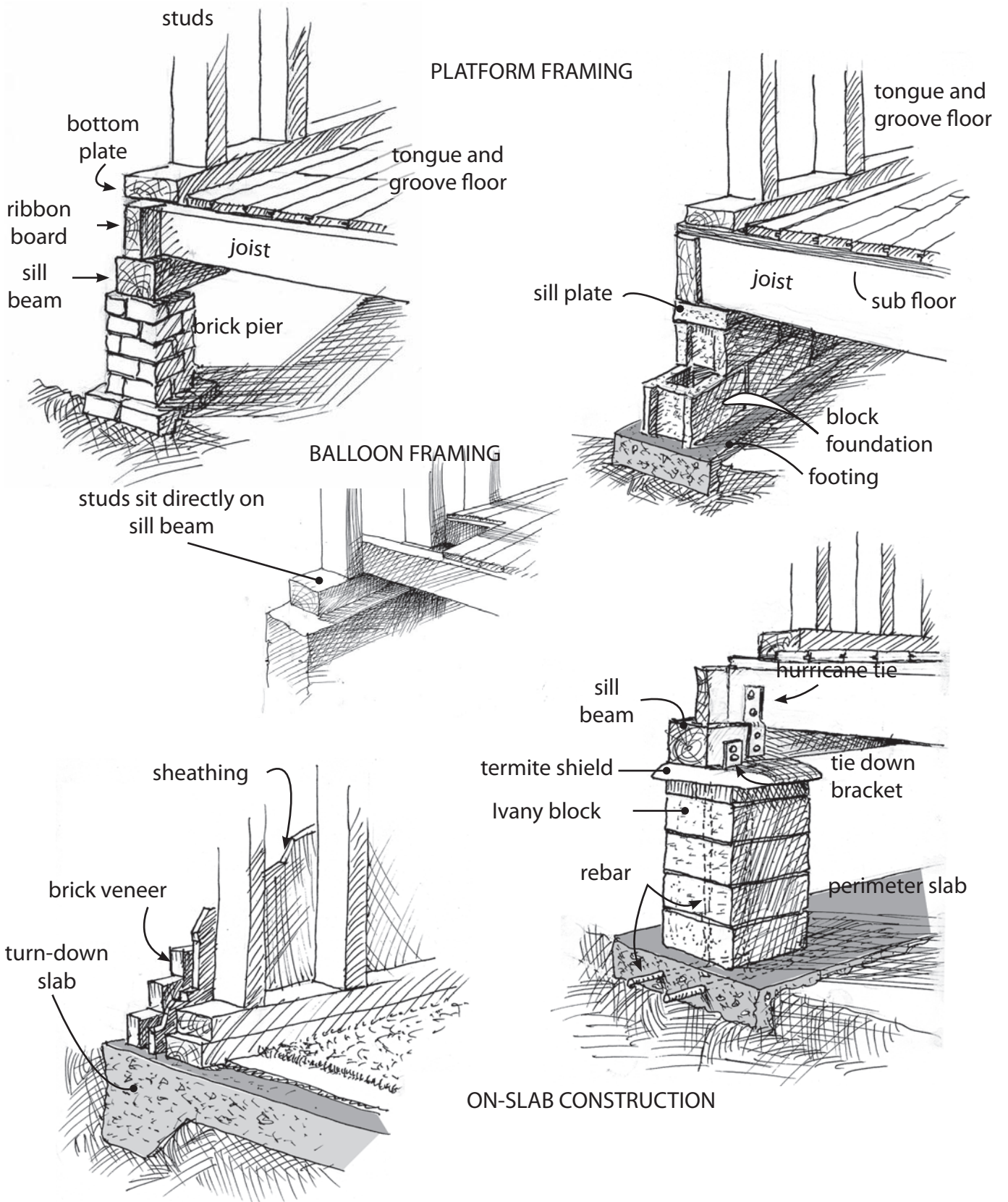

# Roof Structure

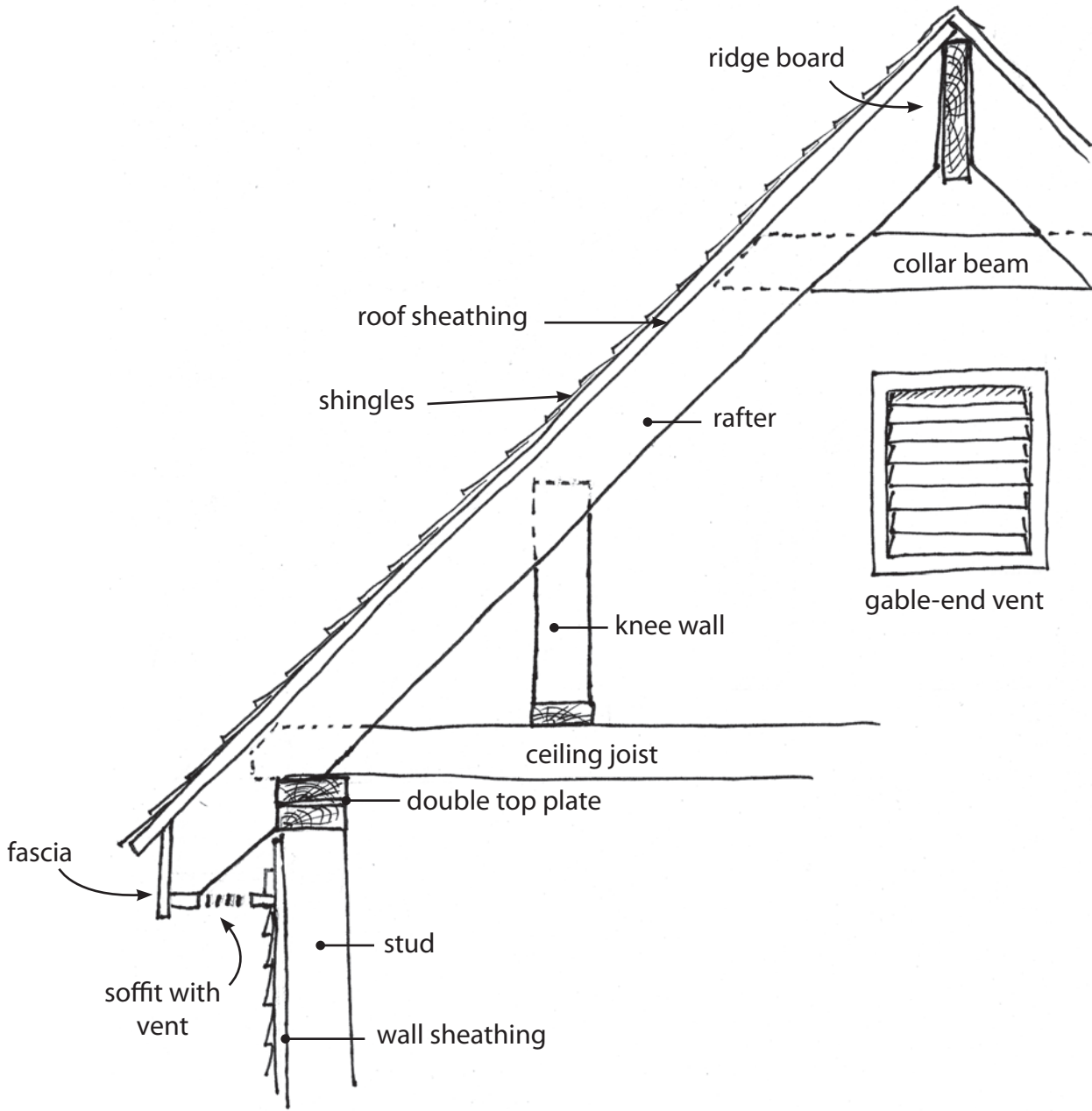



---

## Clean-out Evaluation

### Principles:

1. Do not enter before you know:
  - Is it structurally dangerous?
  - Are the gas and electric turned off?
2. If you enter, wear a respirator.
3. If the building can be saved, see what else can be saved.
4. Make a plan.

# Check Structural Safety

Before entering building, determine if there are structural risks.

- A house shifted off a pier often can be moved back onto repaired or new piers.
- Severe damage to the internal load-bearing structure, including damage to bearing walls, severe wood rot, termite damage, or distortion of the structure  may make saving the building impractical.
- If the building must be taken down, choose deconstruction over demolition. Deconstruction saves valuable material, provides jobs, and lowers the impact on landfills.

## Structural flaws

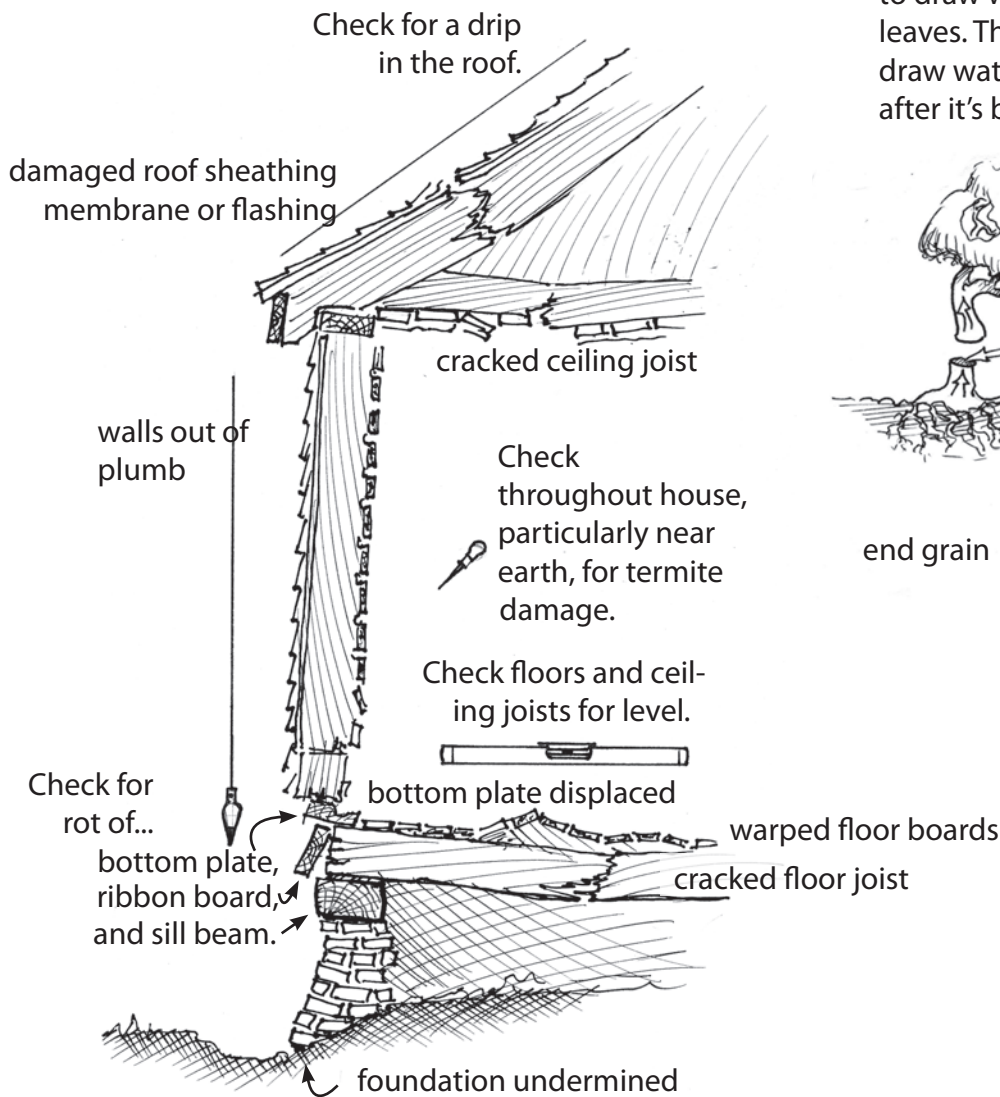

The wood trunk of a tree is “designed” to draw water from the ground up to the leaves. The wood end grain continues to draw water into the lumber’s end grain after it’s built into a house.

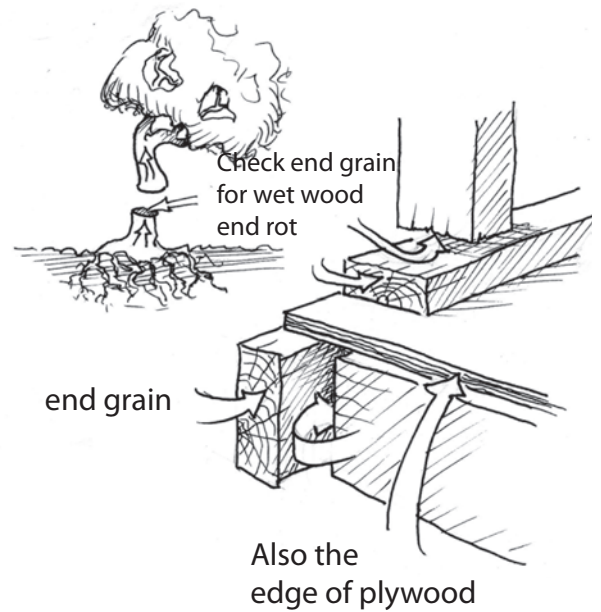

Original tongue and groove floors, plaster walls, doors, and windows should be saved if possible.

# Repair Ceiling and Wall Damage

1. Loose paint can be scrubbed off using a wet abrasive sponge to minimize dust. Repaint starting with a high quality primer. If there is minor cracking in the plaster finish-coat it can be touched up with Global Encasement paint (or similar product). Where surface damage is greater, use the Nu-Wal system (or equivalent, see page 67).

2. Where the finish coat is delaminating from the scratch coat, skim-coat the damaged areas then prime and paint or use new Nu-Wal.

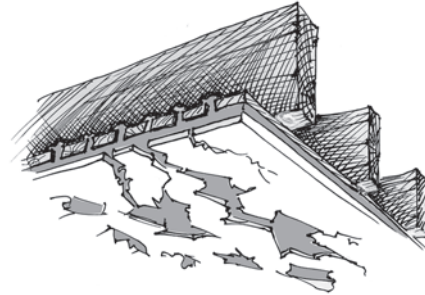

Plaster keys broken off. Keys are formed where plaster squeezes between lath and forms a hook on the back of the lath.

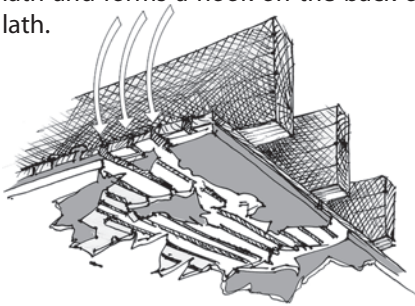

3. Where the plaster keys are broken and plaster is pulling away from the lath, tighten loose plaster back to the lath with plaster washers. Where possible squeeze construction mastic through holes between plaster base-coat and lath. To hold assembly while drying wedge a 2x4 between the floor and a square of plywood held against the ceiling. Where possible squeeze construction mastic through holes between plaster base coat and lath.

Apply base coat of EZ Sand 20 (or similar product) to patch. Be sure it squeezes between the lath, then apply two more coats, allowing drying between coats. Sand final coat.

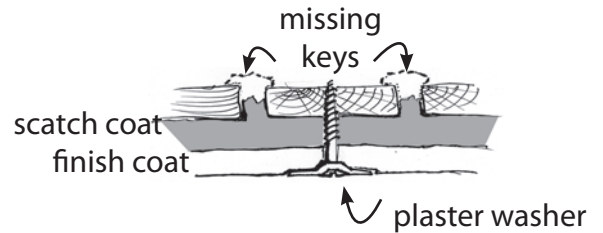

4 Where plaster and lath have broken away from the joist, remove damaged material and, square-off edges. Install sheets of DensArmor Plus or similar product. Fur out bottom of joist so the DensArmor Plus is slightly below the plaster finish coat. Then skim-coat the DensArmor Plus flush with the existing plaster. Use a veneer plaster like Pearl Coat or equivalent product. (It would be preferable to re-plaster the damaged areas if the skill and funds are available.)

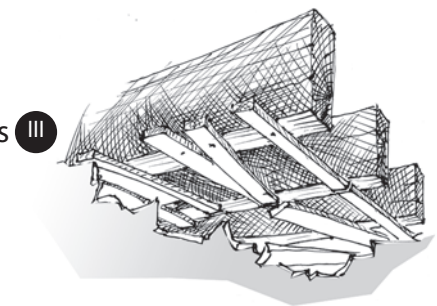

crack in joist

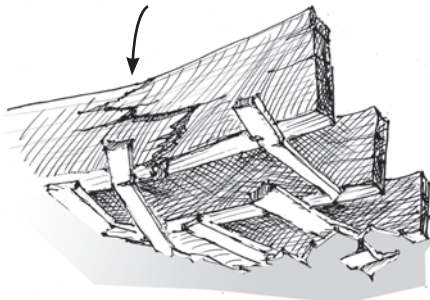

5 Where there is evidence of structural damage to the joist, for example a crack, install a floor-to-joist brace, attaching the brace to both the floor and the joist. Use the brace to push the cracked joist slightly above flush with undamaged joists. Remove the existing ceiling, then attach (sister) a length of lumber flush with the bottom of the cracked joist. It should extend at least 4ft. from the crack in both directions, or be set on the nearest wall. Attach the sistered lumber with bolts so it can be adjusted to be exactly flush with the existing ceiling.

# Utility Shut-off



Before entering the building to work, check the safety of electric, natural/LP gas connections, and water/sewer service. Report apparent problems to the appropriate utility or agency.

Report any loose or damaged electrical service cables

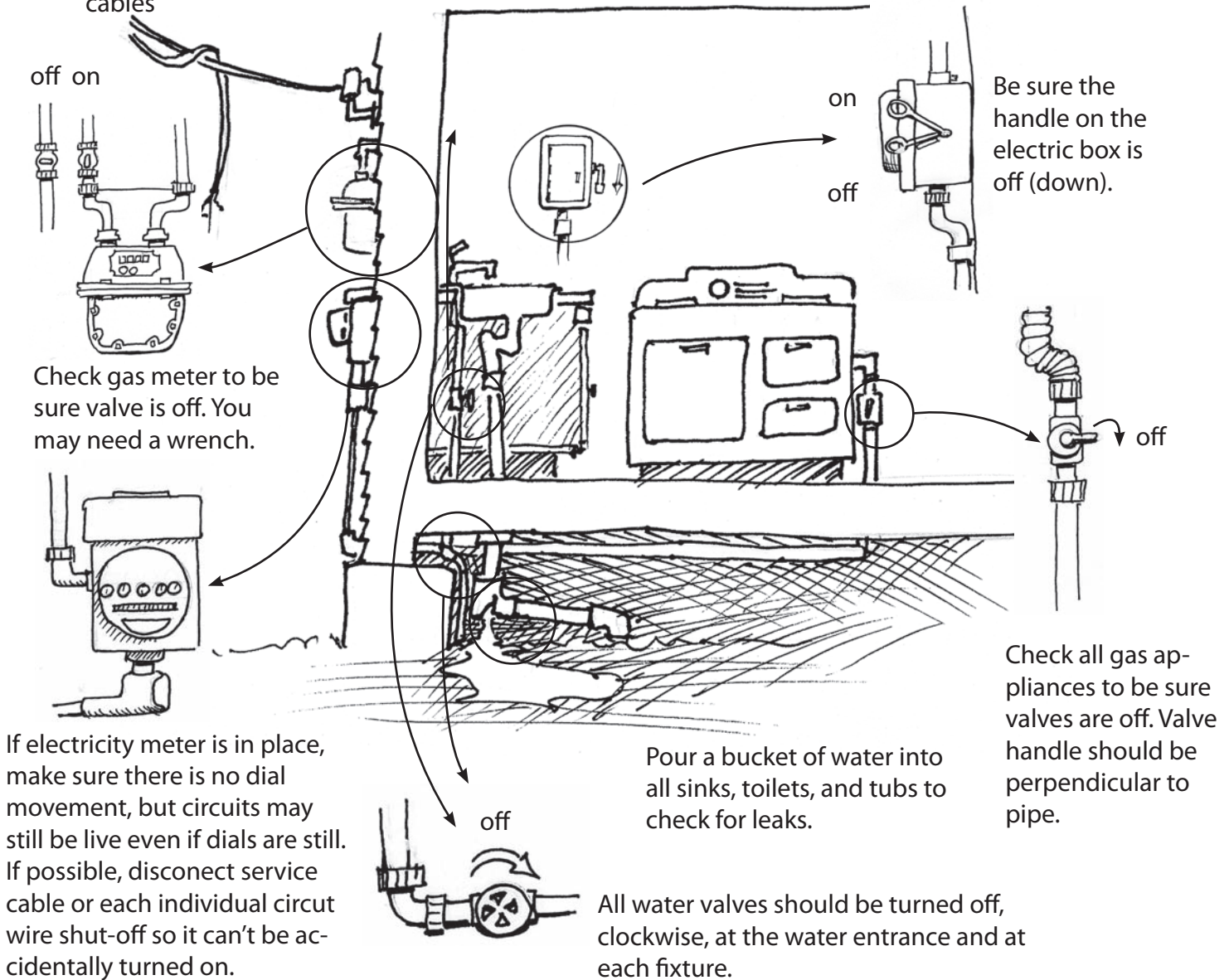

- Unless the electric system has been inspected and approved, make sure there are no live electric lines on the property or within the house. Damaged electric lines entering the house should be removed. Call the electric utility company to report such issues.
- If there is any indication gas is entering the house, leave the premises, call 911 and call the utility company.
- For problems with water service, call the water utility.

# Health Risks during Clean-out

## Mold

Mold levels may be dangerously high in flood-affected homes, and increase when moldy items are disturbed. Long-term or heavy exposure is unhealthy for anyone, and particularly children or anyone with respiratory problems. Mold can trigger allergic reactions and asthma attacks, lower resistance to illness, and cause other health problems. If you can see it or smell it you don't need to test for it.

## Dehydration

High humidity increases the risk of dehydration, since it reduces the efficiency of sweating. Dehydration can start before we get thirsty!

Some signs of dehydration in various stages:

- mild: increased thirst, dry lips, and discomfort
- moderate: nausea, sunken eyes, increased body temperature, difficulty concentrating
- severe: weakness, confusion, rapid/weak pulse, cold hands/feet, rapid breathing, lethargy and muscle spasms

Strategies for preventing dehydration:

- Drink before, during, and after exerting work in high temperatures. Try to consume 4-8 oz. of water every - 30 minutes during heavy activity. Fluids at room temperature replace lost fluids faster than chilled fluids. Avoid caffeine and alcohol. Drink extra water (at least 2-3 cups of water or electrolyte solution to prevent dehydration.
- Check with your doctor about the medications you are taking. Anti-histamines and some blood pressure medications decrease sweating and therefore increase risk.
- Dress in light colored fabrics that breathe.

## Lead dust

Homes built before 1978 may have paint that contains lead. Lead dust eaten or inhaled can cause permanent brain and nerve damage. Lead is most dangerous to young children, but it can harm people of any age. Water damage can cause paint to flake and peel. If this happens, small particles of lead paint in the home can be dangerous to workers and residents. Unless you are able to test floors and other surfaces for lead dust, to make sure lead dust levels are low, assume there is a danger. Use proper precautions to prevent exposure and clean surfaces thoroughly before people return to live in the home. Lead dust created by demolition is particularly dangerous. NEVER dry sand or power sand without a vacuum attachment and NEVER burn off old paint. Heat guns are discouraged even if kept below 1100 degrees Fahrenheit, the Federal limit. Avoid chemical strippers in poorly vented spaces and under no circumstances use strippers containing methylene chloride

For information on lead-safe work practices, see the federal Lead Paint Safety Field Guide, [www.hud.gov/offices/lead/training/LBPguide.pdf](http://www.hud.gov/offices/lead/training/LBPguide.pdf), or order a copy of Maintaining a Lead Safe Home (see appendix for ordering details).

#### Asbestos

Asbestos is a natural mineral fiber used in some building insulation (pipes, siding, wall or ceiling insulation), spray-on textured ceilings, and ceiling and floor tiles, especially before 1981. Any home may contain asbestos. When broken or disturbed, asbestos-containing materials produce airborne fibers that, if inhaled, can later cause serious diseases like asbestosis, lung cancer, and mesothelioma. It is dangerous to clear and haul asbestos-containing construction waste from homes without using proper protective equipment, including a full face respirator with HEPA filter cartridges and a full body suit. Disposable face masks, except N100s, R100s, or P100s offer very little protection.

Get professional advice regarding safe asbestos removal. Even the tile glue may have asbestos in it. When working with asbestos, keep it wet so tiny particles will less likely become airborne, use plastic sheeting to collect debris, and dispose of smaller asbestos pieces and collected dust in plastic bags that are clearly labeled "asbestos waste."

#### Toxic sediment

Floodwaters can leave a layer of sediment of soil, sewage, and toxic chemicals. Testing by EPA and environmental groups following Hurricane Katrina in 2005 showed unsafe levels of arsenic and chemicals from diesel fuel in many communities. In some communities, dangerous levels of heavy metals (lead, cadmium, mercury), pesticides, and other chemicals have been documented. Workers and returning residents should take precautions to avoid breathing or ingesting the sediment. Try to avoid contact with sediment, wear protective equipment and clothing, and clean sediment from indoor areas and, wherever possible, outdoors.

#### Electric shock

Shocks can kill. There is danger from any electric device that has been flooded. Rubber boots and gloves do not always protect from electric shock. When touching an electric box, stand on dry spot and manipulate with a dry stick or rubber-handled tool.

### Carbon monoxide

Carbon monoxide (CO) is an odorless, colorless gas that can cause sudden illness and death through asphyxiation. Even small doses over time can cause brain and heart damage. Burning fuels such as gas, oil, kerosene, wood, or charcoal produces CO. Do not use fuel-burning equipment, including portable generators, unvented gas heaters or unvented propane heaters, inside flood-damaged homes. Operate outdoor generators at least 10 feet from windows, doors, and other openings to dwellings. Check and repair damaged water heaters, furnaces, ovens, and stoves. Repair and clear any vents or chimneys that are damaged or obstructed. Seek fresh air immediately if you feel dizziness, nausea, or weakness.

### Cuts and punctures

Broken glass, boards, exposed nails, and other sharp objects are common in storm-damaged homes. Also, floodwaters may contain germs that can enter the body through cuts and scrapes.

- Wear protective gear to prevent serious injury. Take special care to protect your hands and feet.
- Make sure you and your co-workers have current tetanus shots (within the last 10 years) before working in flooded areas.
- If a cut or puncture occurs, wash it immediately with soap and water. Treat with antiseptic ointment.

### Falls

Broken bones, head injuries, or even death can result from falls from ladders, windows, porches or roofs.

### Critters

Caution must be used to avoid bites from snakes, fire ants, rats, etc. Clearing out from a cleaned out space increases safety.

### Fire / explosion

Be positive gas is turned off, propane is removed, and solvent impregnated materials are removed from the house.



### Clear-out Procedure:

- 1 Open house, and if electricity is available, use window fans blowing out.
- 2 Remove all objects.
- 3 Shovel out any soil.
- 4 If functional plumbing is available, hose down floors.
- 5 Open bottom and top of walls. If electricity is available, run fans and dehumidifier.
- 6 Disinfect all materials to be saved.
- 7 Treat structure with borate solution.

# Everyone Needs to Take Some Basic Precautions.



Don't smoke. If you must smoke, leave the work site.



Always pull or bend over nails.



Don't eat on the work site, or drink water in the work area.



Protect yourself from direct sun and heat stroke. Take breaks, drink water, and use fans where possible.



Don't touch or rub your eyes.



It is critical to drink water frequently.

## All Work Sites Should Have Access to:

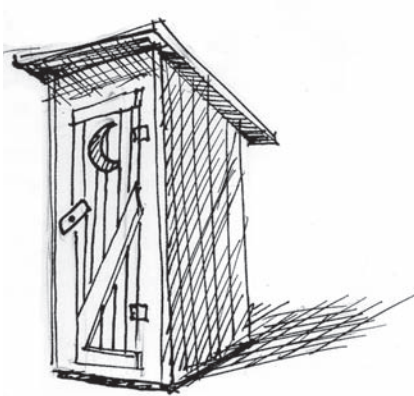

a toilet



water for washing



a first aid kit



water to drink



a cool, clean, comfortable place to take breaks



...and, if possible, access to electric outlet or generator for:

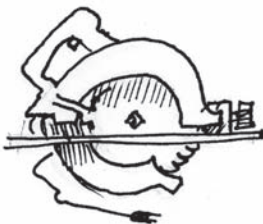

power tools

Use hand tools when you don't need production speed.

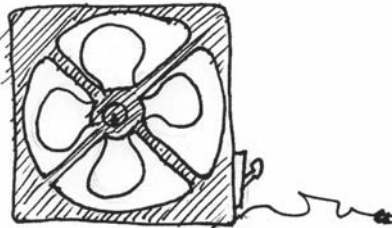

ventilation

Air movement keeps you cooler and healthier.



light

A well-lit work site is a safer work site.

# Prepare for Personal Health and Safety



safety glasses & cap...

Where there is no dust risk, wear glasses or safety glasses and a brimmed cap to protect your eyes and hair.

..plus respirator

Where there is risk of dust or mold exposure, also wear an N100, R100, or P100 respirator. Replace it when it gets dirty. According to OSHA\* an N100, R100, or P100 respirator is as protective as, or more protective than, a half face negative air respirator.



negative air respirator

If there are fumes, such as when you are using an infrared heat gun (particularly on lead paint), wear a half face negative air respirator with carbon filters. These filters are black.



positive air respirator

Where a person's beard prevents wearing a respirator, or a loose hood is more comfortable, wear a positive air hood. This works particularly well when working on your back under a building and spraying above yourself or in a hot confined space such as an attic.

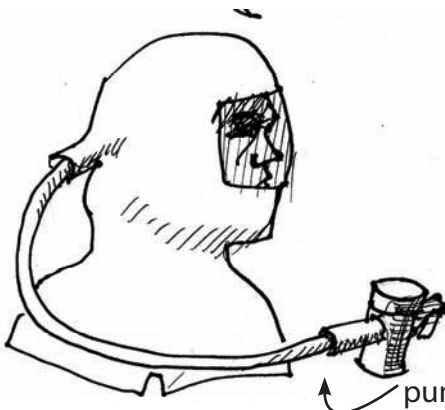

pump and filter go on belt

disposable suit

Wear breathable, disposable suits with elastic ankles and wrists in high dust/mold work. If you don't wear a suit, be sure to change work clothes, or at least vacuum them, before going home.

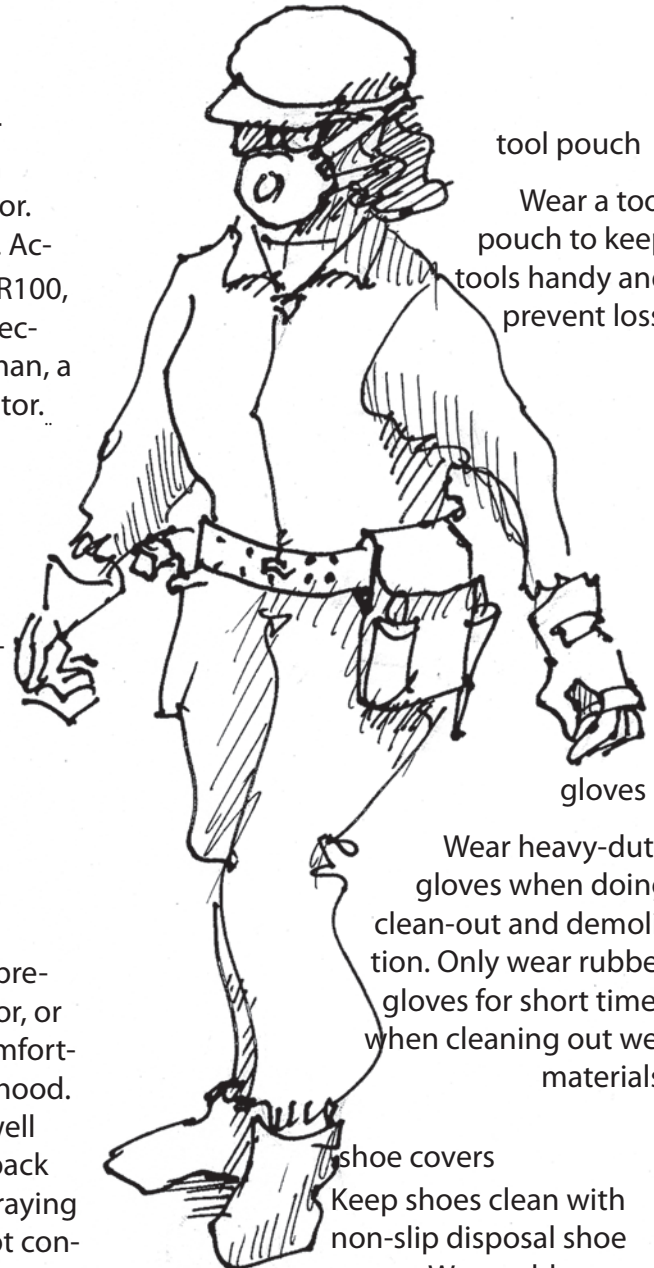

tool pouch

Wear a tool pouch to keep tools handy and prevent loss.

gloves

Wear heavy-duty gloves when doing clean-out and demolition. Only wear rubber gloves for short times when cleaning out wet materials.

shoe covers

Keep shoes clean with non-slip disposal shoe covers. Wear rubber boots in the presence of water.

\* Federal Register: August 24, 2006 (Vol.71, No.164) pg. 50121-50192. [www.access.gpo.gov](http://www.access.gpo.gov).

# The Completed Clean-out Site Has:

Separate trash areas for:

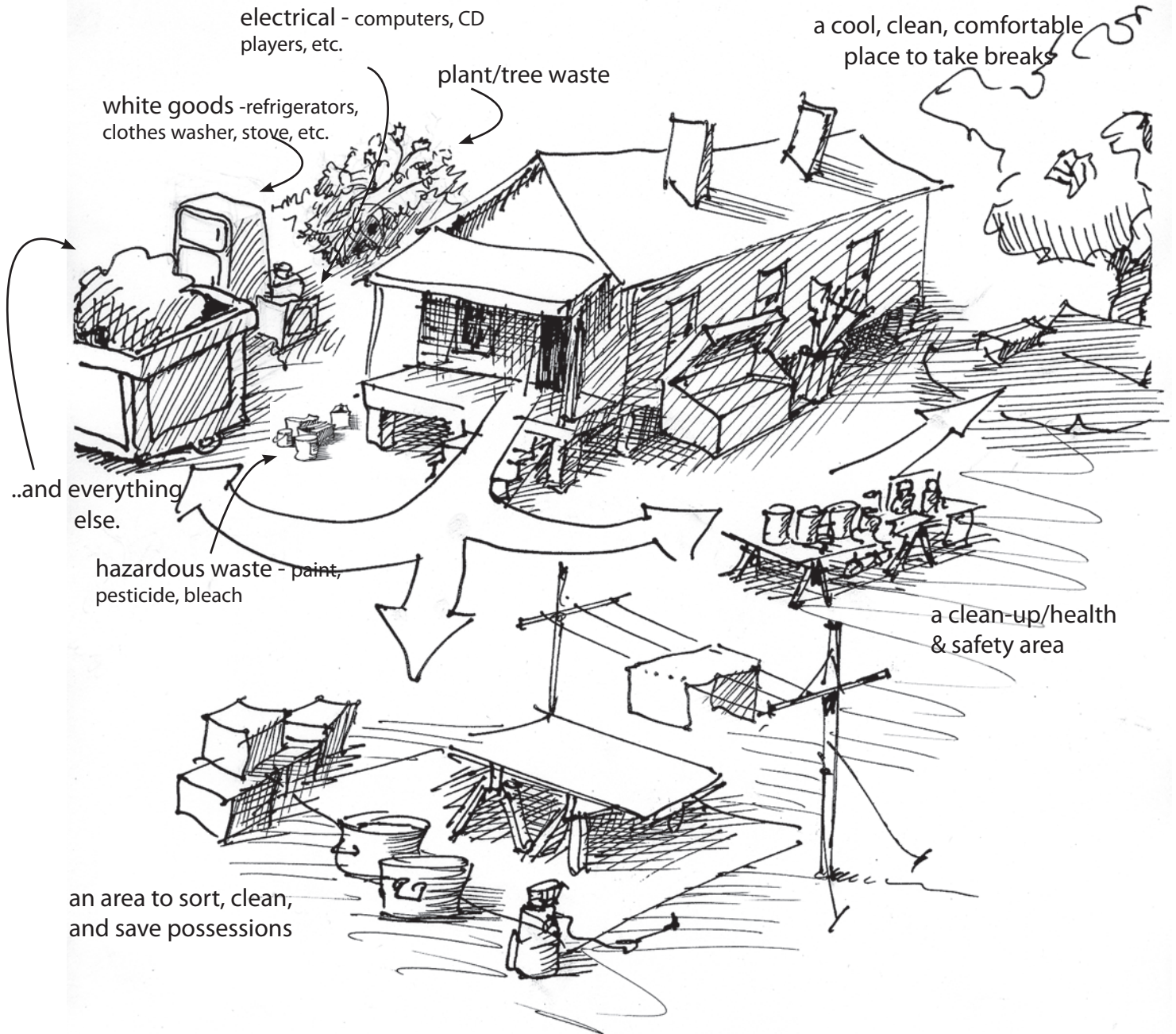

# The Clean-up, Health and Safety Area

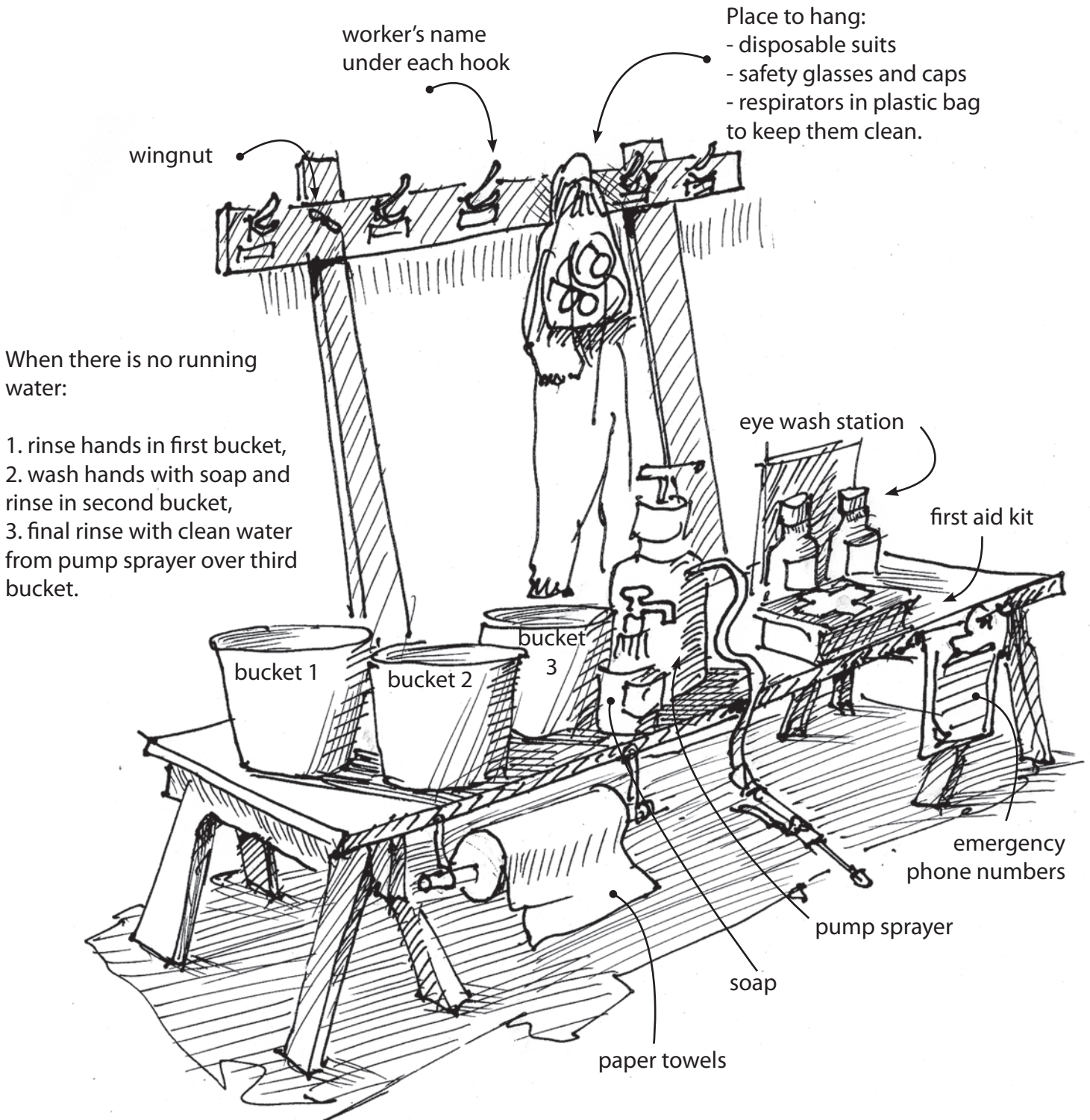

When there is no running water:

1. rinse hands in first bucket,
2. wash hands with soap and rinse in second bucket,
3. final rinse with clean water from pump sprayer over third bucket.

# A Comfortable, Shaded Place to Take a Break

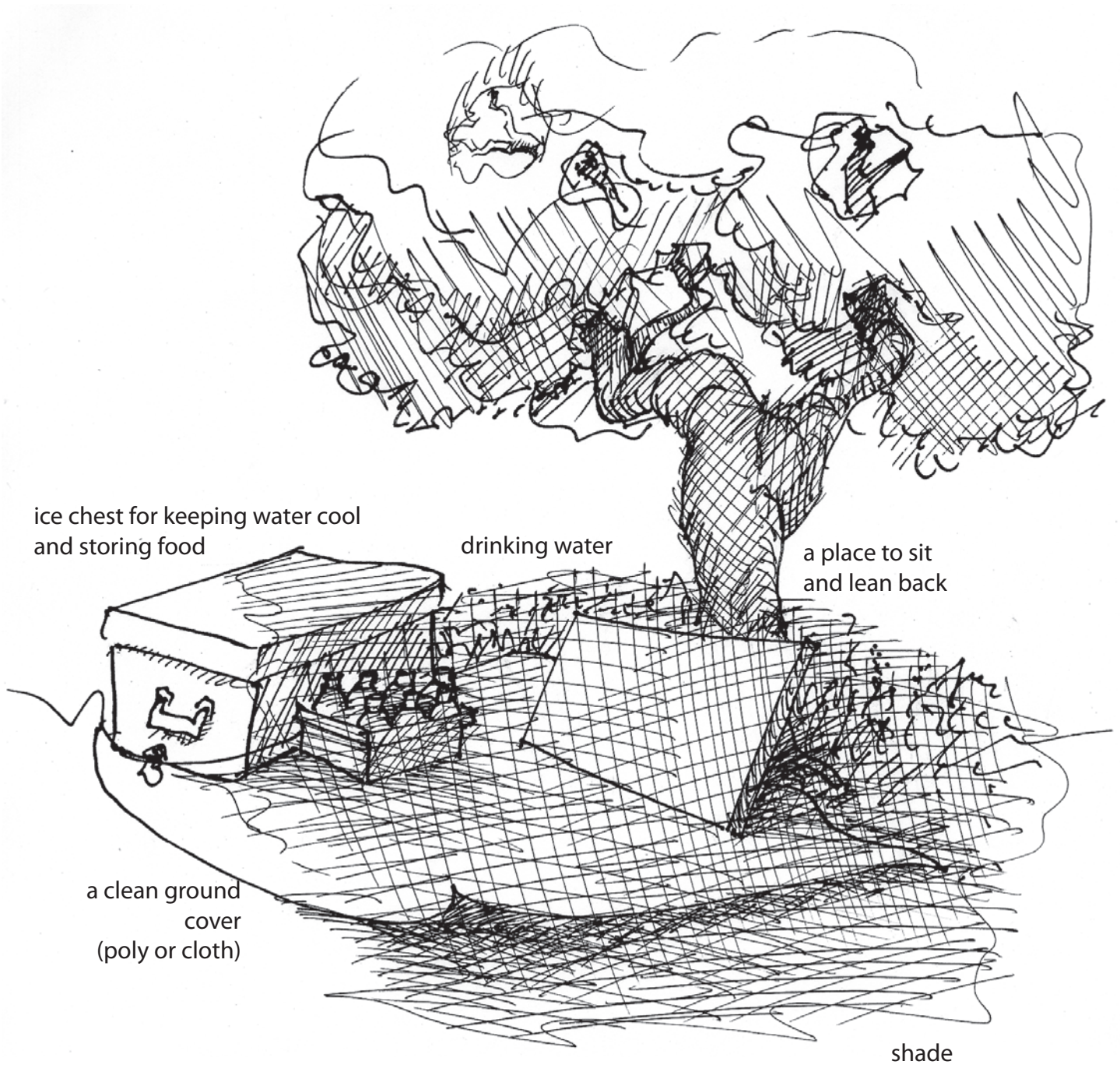

# Possession Clean-up Station

Where possible, locate this operation in a garage or under a tent.

drying rack - place to hang cloth to dry  
Once dry, material should be re-washed or dry-cleaned.

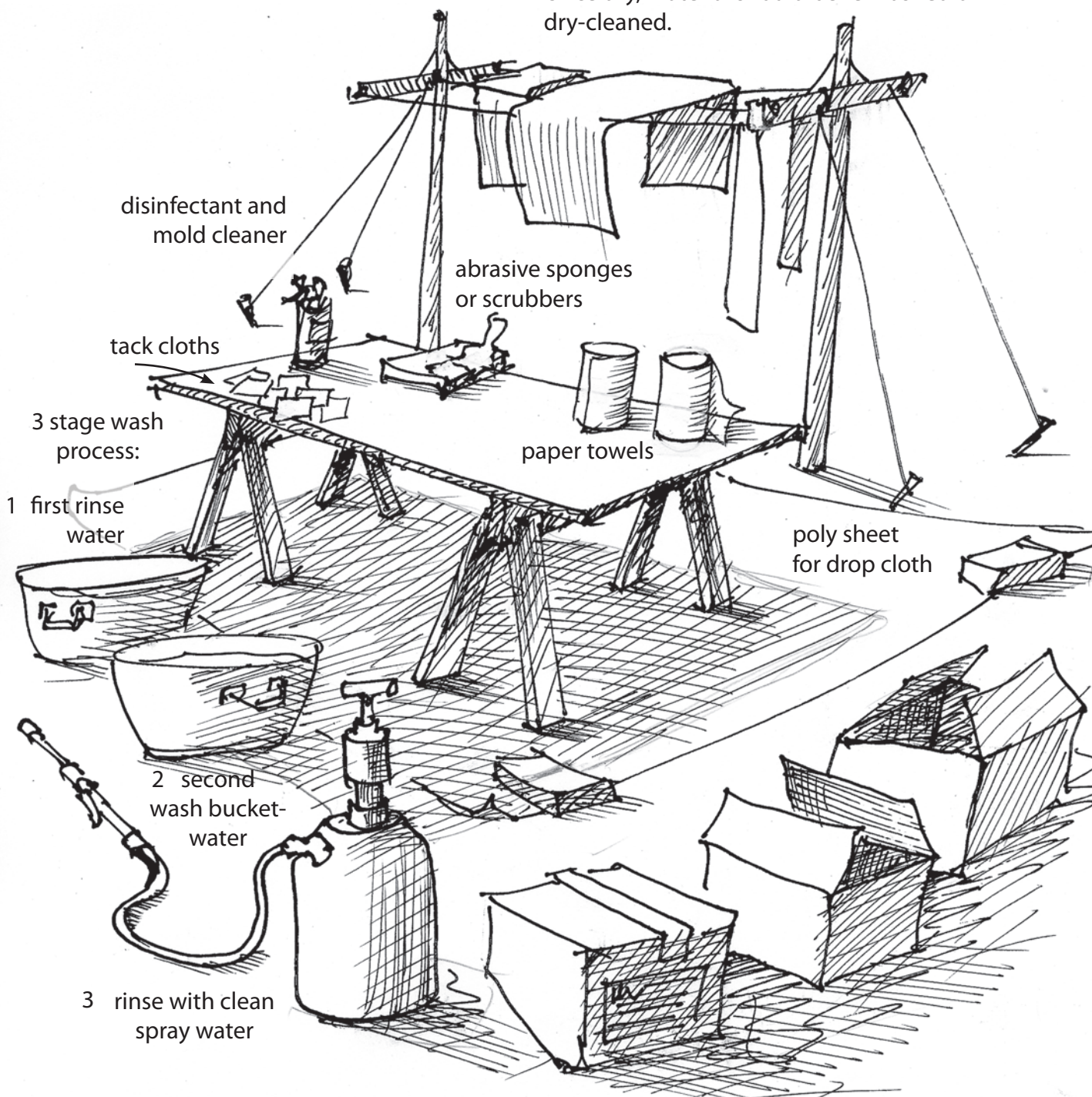

Dry out possessions to be saved. Then place them in boxes which are marked with contact information of owner.

# Sort Contents That Have Been Submerged As You Remove Them

Always dispose of:

- food (undamaged canned food can be saved)
- cosmetics
- children's stuffed/cloth toys

If they got exposed to flood water, dispose of:

- mattresses
- pillows
- upholstered furniture (if valuable, remove upholstery and save frame to be re-upholstered)
- wall-to-wall carpet (area rugs can be hosed off, dried, then sent to a rug cleaner)
- electric appliances
- paper - books, documents (sometimes important documents can be dried out and saved)
- particle board and other engineered / composite wood products.

Try to save:

- records and CDs (record jackets may need to be disposed of)
- anything that didn't absorb water and can be wiped clean, such as solid wood furniture (pressboard furniture usually can't be saved), metal, pottery, ceramic, plastic, and glass.
- washable curtains, draperies, and valuable rugs

Make five piles of objects being discarded:

- vegetation- tree branches, etc.
- electric appliances such as TV and computer
- toxic materials- paint, insecticide, etc.
- large appliances (white goods) including washing machines, refrigerators, dryers, stoves, etc.
- everything else

## Finishing Clear-Out

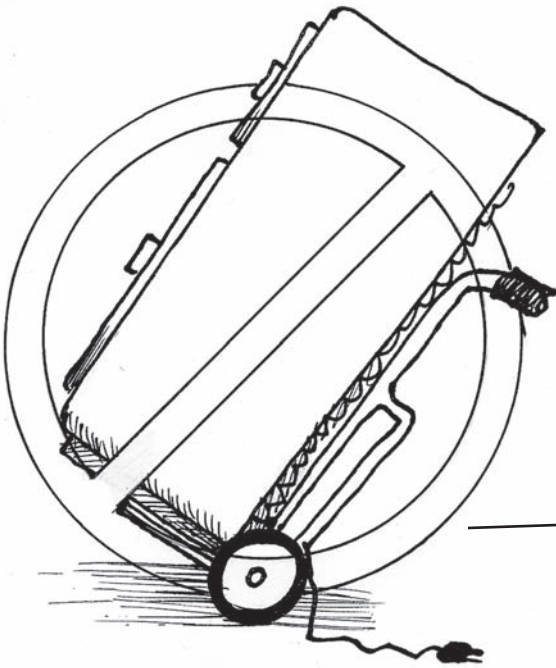

Don't move large appliances on a hand-truck as it can easily tip over.

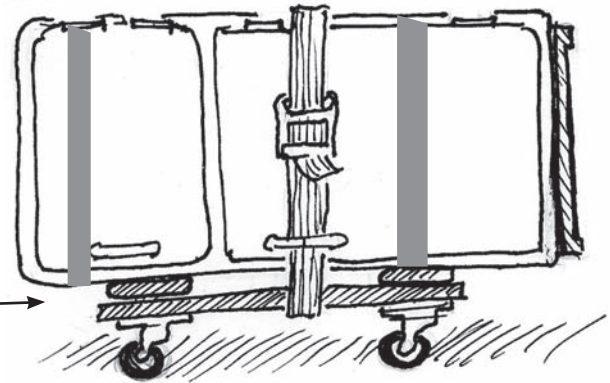

Instead tie it onto a dolly. Duct tape a refrigerator door's shut before moving and move on its side to avoid damaging coils.

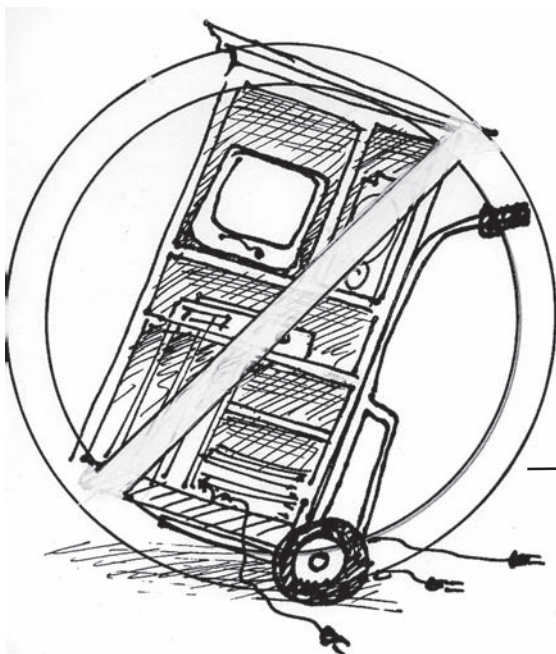

Large cabinets weakened by water, particularly those made of pressboard, can collapse when being moved.

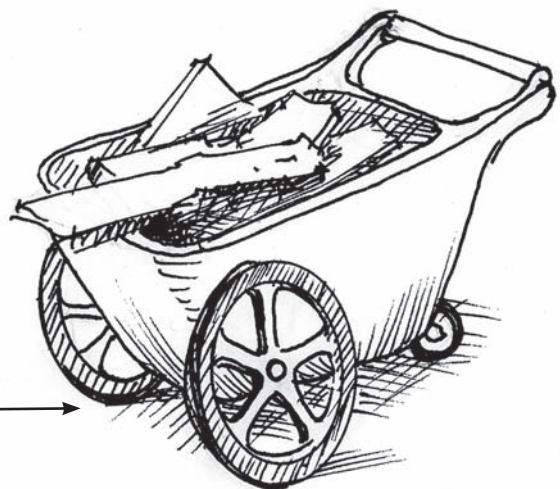

Empty cabinets out and, if they are weak, take them apart before moving. A Big Wheel Cart  is far more effective, safe and easy to use than a wheel barrow.

# Save What Can be Saved

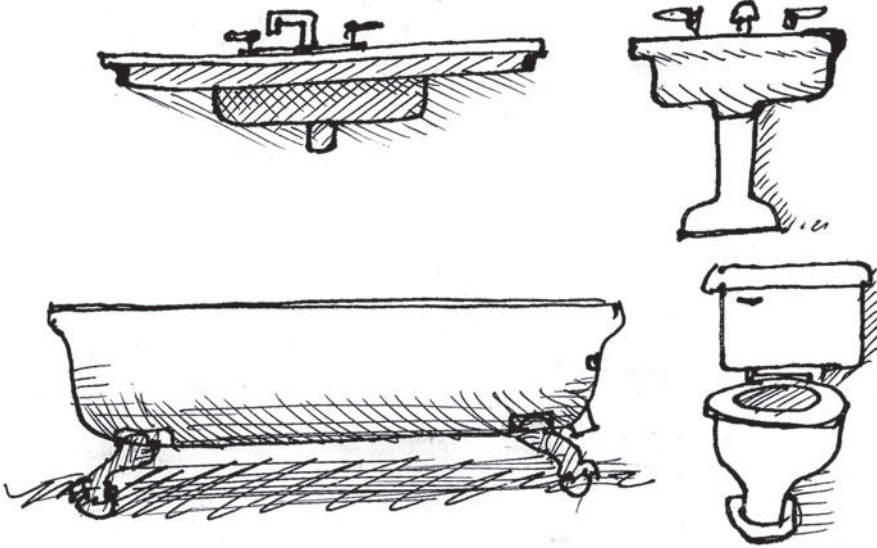

## Plumbing fixtures

Save installed sinks, toilets, and tubs when possible. If they must be moved, clean and store or give away.

## Furniture

Upholstered furniture that has been soaked usually needs to be discarded. Valuable furniture may be stripped and re-upholstered. Solid wood or metal furniture can usually be saved. Cushions must be discarded.

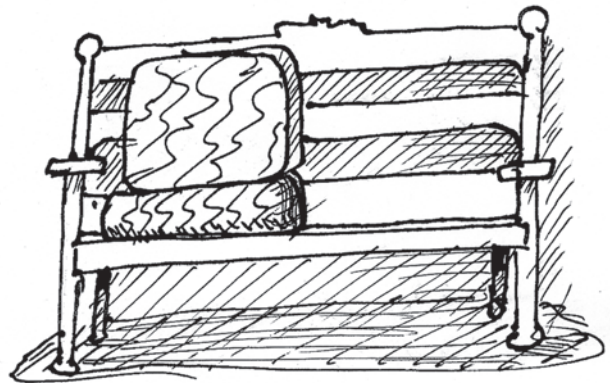
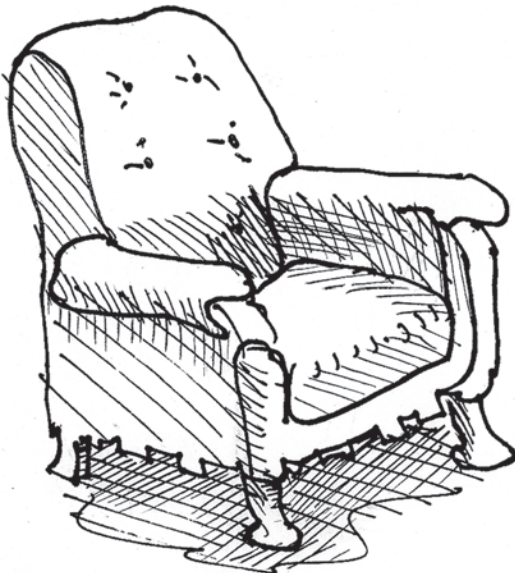

## Wall to wall carpet

Cut wall-to-wall carpet into easily moved pieces before disposal. Create a clean central path and work out from there. Using a stand up cutter  makes the job much easier

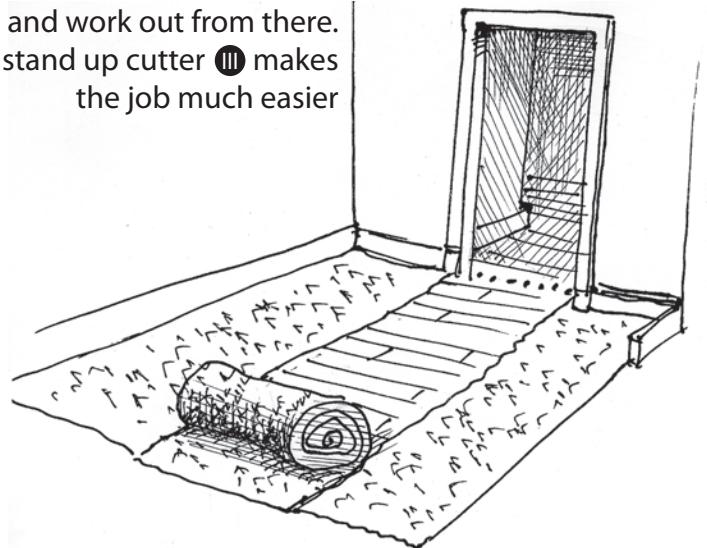

## Valuables

Separate and dry out valuable art, photographs, documents, rugs, etc. for possible restoration

# Plaster Removal

Plaster walls with no insulation can be dried out, cleaned and restored. Try to save plaster walls because plaster resists mold and roaches. It also lasts much longer than drywall, can be easily maintained, and has historic value.

If wall contains insulation that was in contact with flood water, it should be disposed of. Remove baseboard, cut channel slightly shorter than the baseboard, and remove insulation from the wall's base.

Once you have access to wall cavity, thoroughly treat it with borate and seal it up.

If plaster walls must be demolished, cut a channel, insert hook of crowbar behind lath, and pull. Two or three people doing this together works best. This will put the lath on top so it can be easily picked up. Lay it on a looped piece of rope, bundle it, then remove it separately from the plaster. Wear heavy gloves to protect your hands from nails.

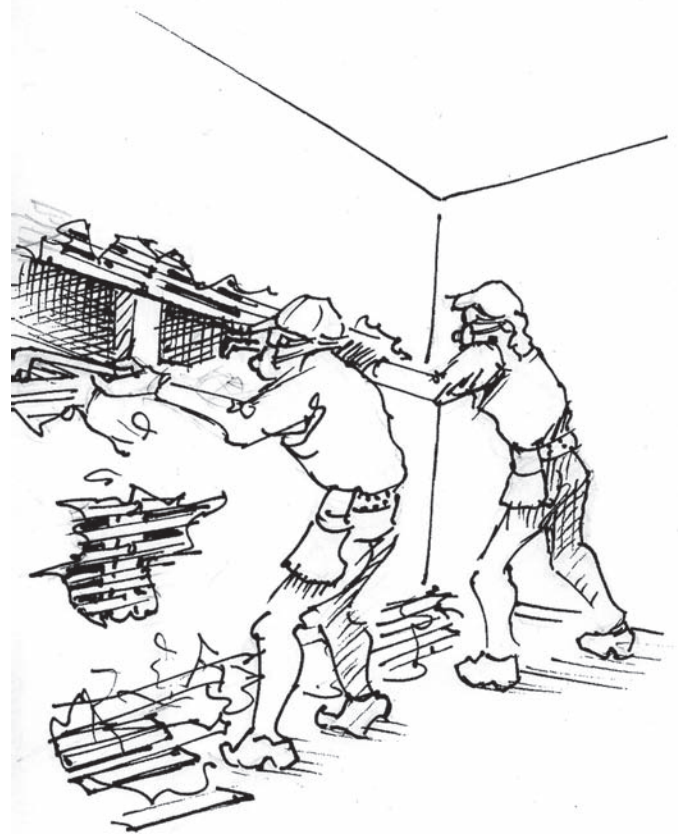

work with your head close to the ceiling

Never pull ceiling down on yourself

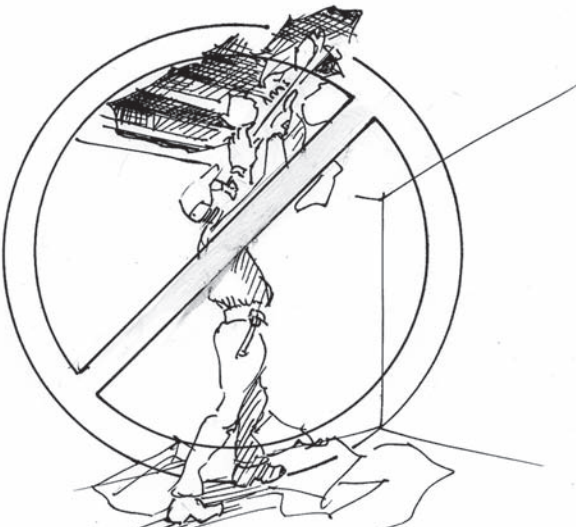

Work from a ladder so the ceiling can be pulled down in front of you. Use a tall enough ladder so you don't need your hips to be above the top of ladder. Never set the ladder on rubbish. Sometimes you can work from the attic while standing on a plywood sheet to avoid falling through the ceiling. Use a sledgehammer or other heavy tool to gently push ceiling down.

# Cleaning Work Sequence



Always clean from a clean area.  
Don't walk on piles of rubbish.

where there is no front or side access

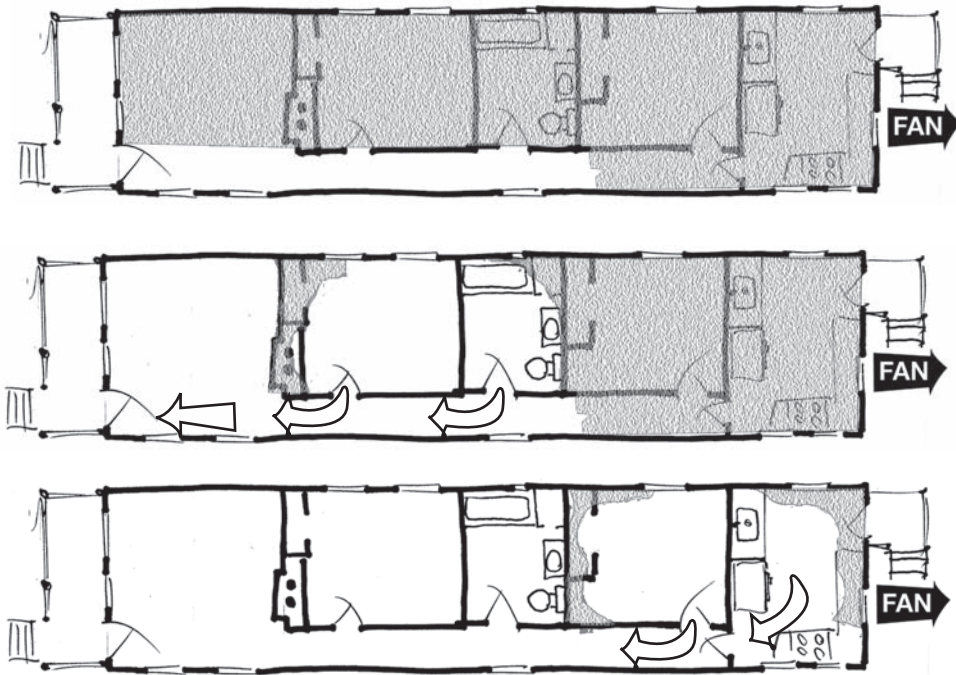

- Start cleaning out from a place that's already clean.

- Carry materials the shortest possible distance to the outside.

- When possible, run a fan to pull air from cleaned areas toward dirty area to exhaust outside.

- Where accessible, discard trash through window directly into cart.

where there is rear and/or side access

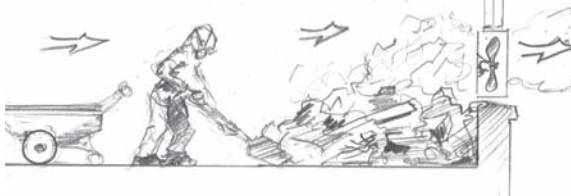
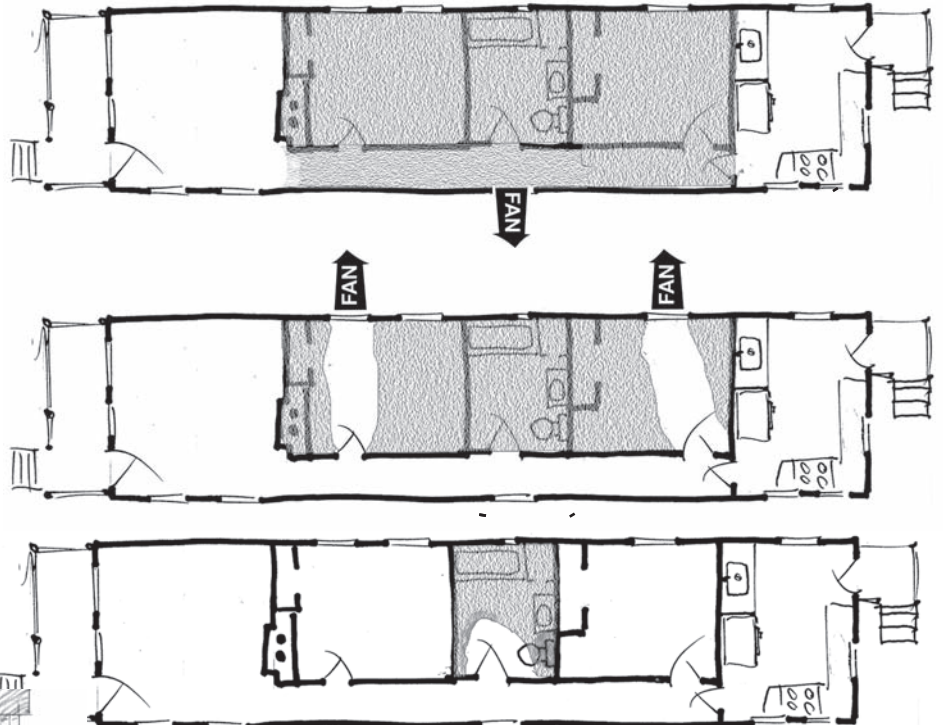

# Some Specialized Tools

Mention of specific product names does not imply any endorsement by HUD or the Alliance. See Appendix III for sources.

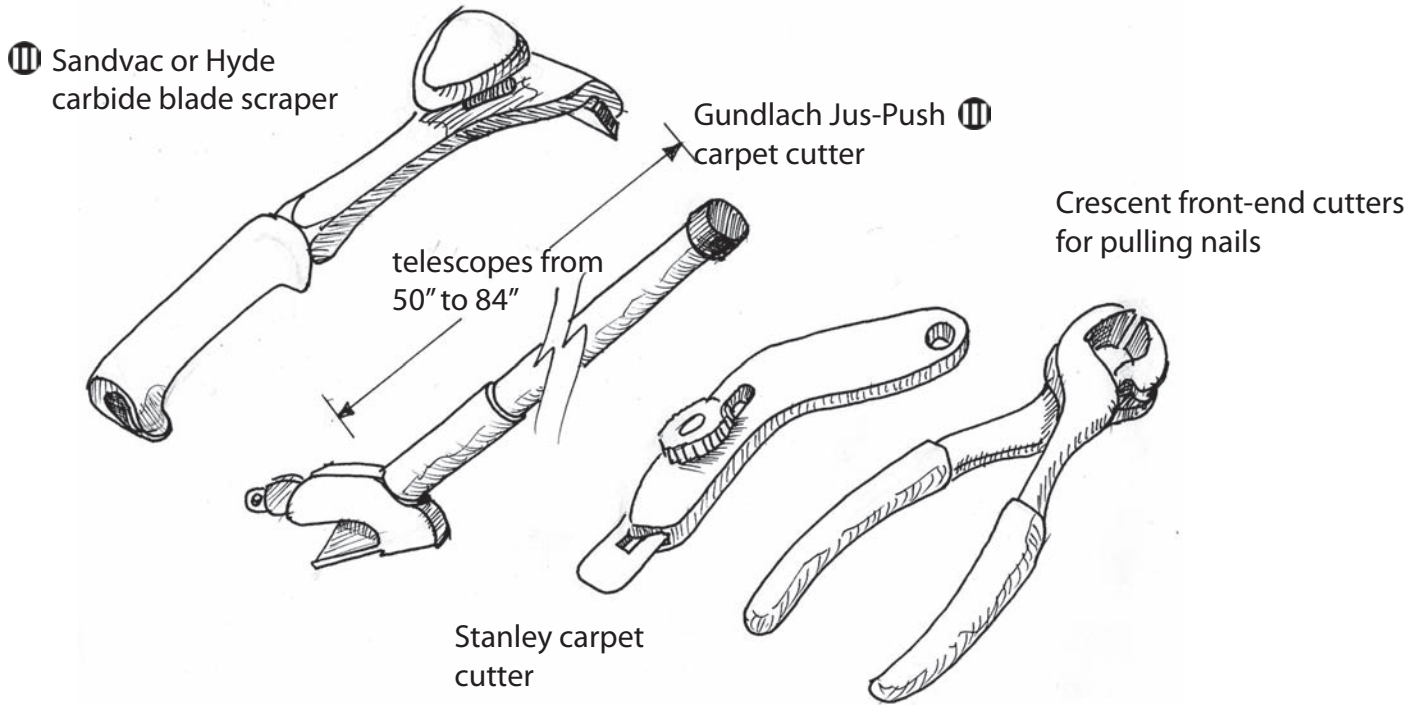

An inexpensive pump sprayer that runs off a car battery for borate treatment. Ⓜ

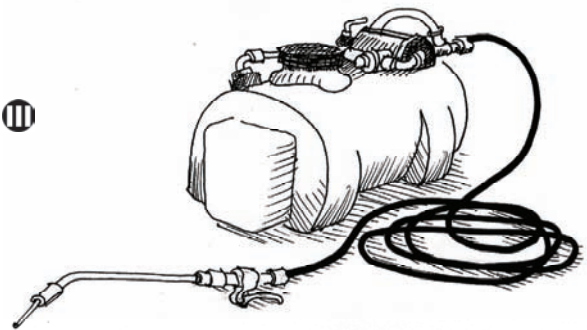

Using loose boards or hollow core doors for a ramp over steps can cause injury and make work more difficult.

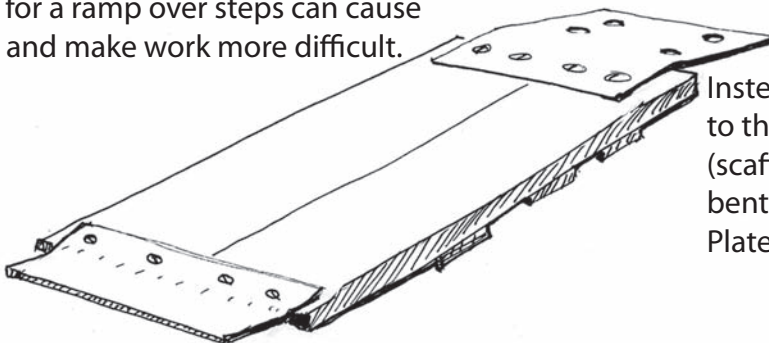

Instead fabricate a safe ramp; Screw battens to the underside of two 5/4" x 12" boards (scaffold boards). Fabricate two pre-drilled, bent, steel plates. Then attach to each end. Plates can be used on any size ramp.

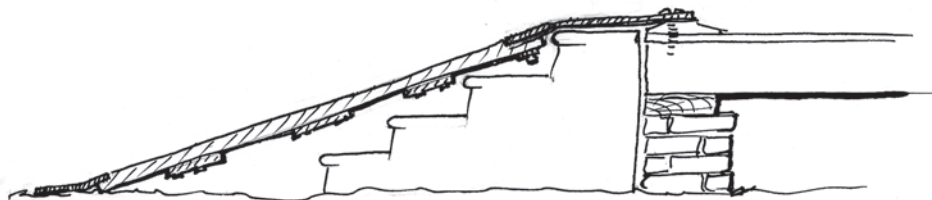

Screw top of ramp to threshold, floor, or top of steps.

# Security Systems for Windows and Doors

This system can be used until you move back in. If there is storage space available, the system can be retained and reinstalled to protect the house from strong winds.

## Windows

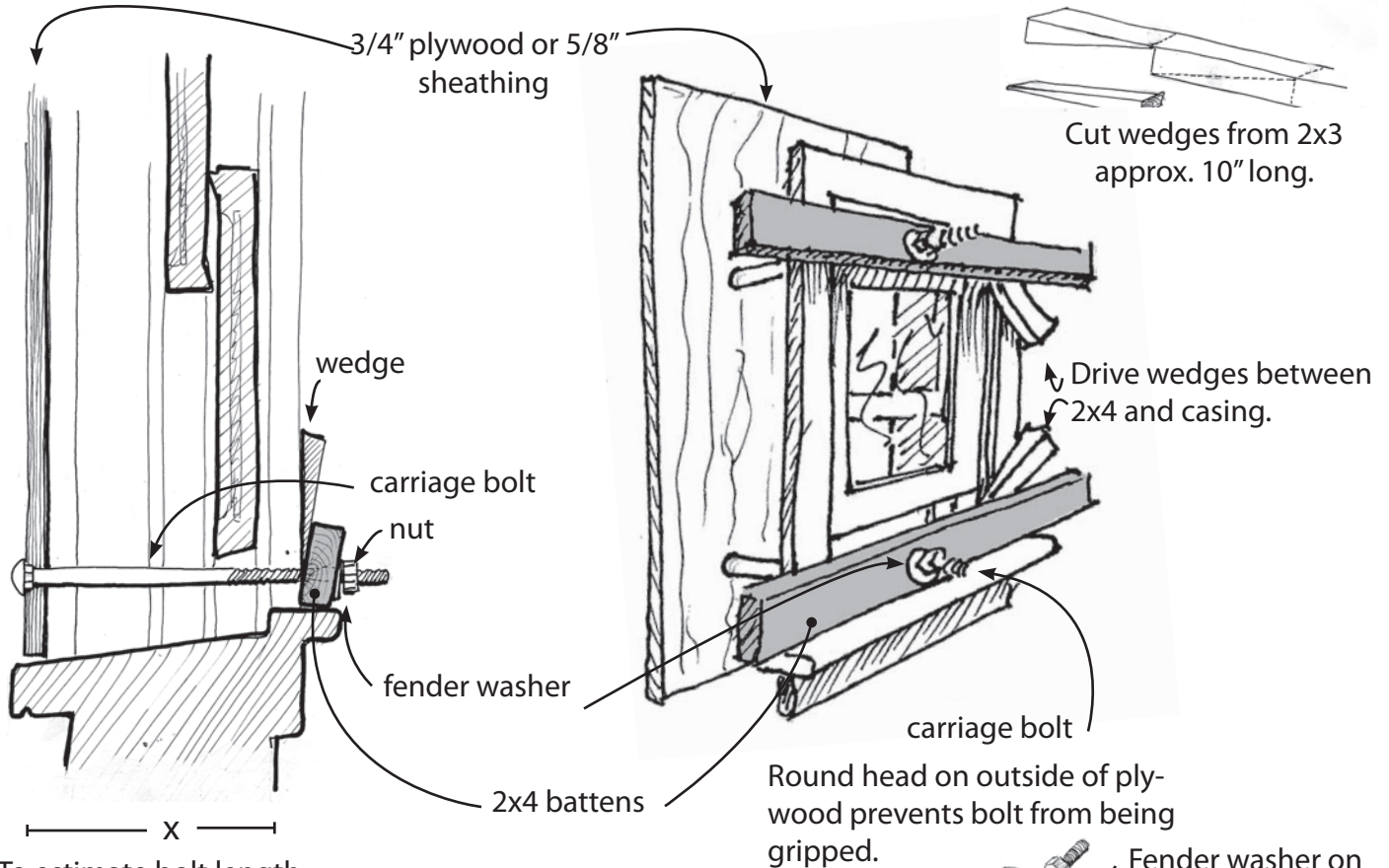

To estimate bolt length, measure face of outside casing to face of inside casing "X" then add about 5".

## Doors

To secure door that is not the main entrance, cut 3/4" plywood or 5/8" sheathing to size of the door

Screw a piece of wood on to plywood at about 4 ft. up from the floor...

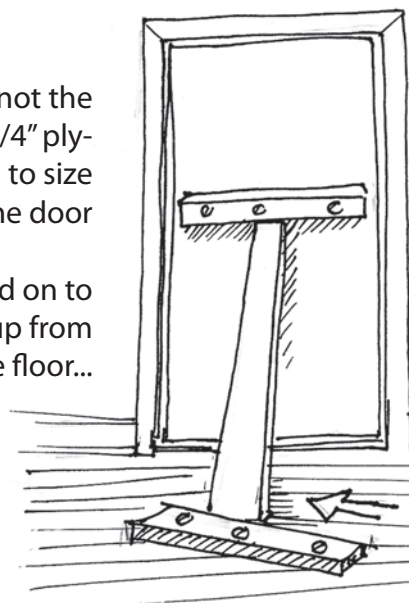

.....then screw a 2x4 to the floor at a slight angle to the door. Insert third 2x4 and kick toward angled end of the floor brace. This will tighten the brace against the door batten.

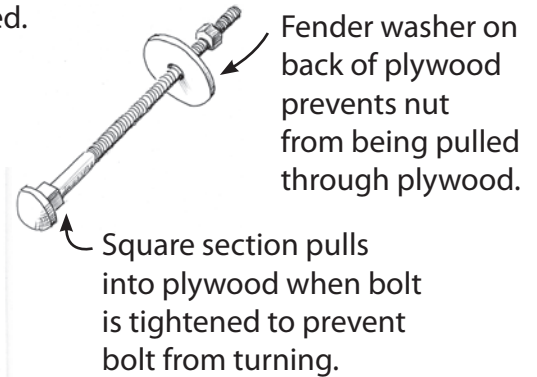

# Entrance Door Security

lock system for the primary entrance door

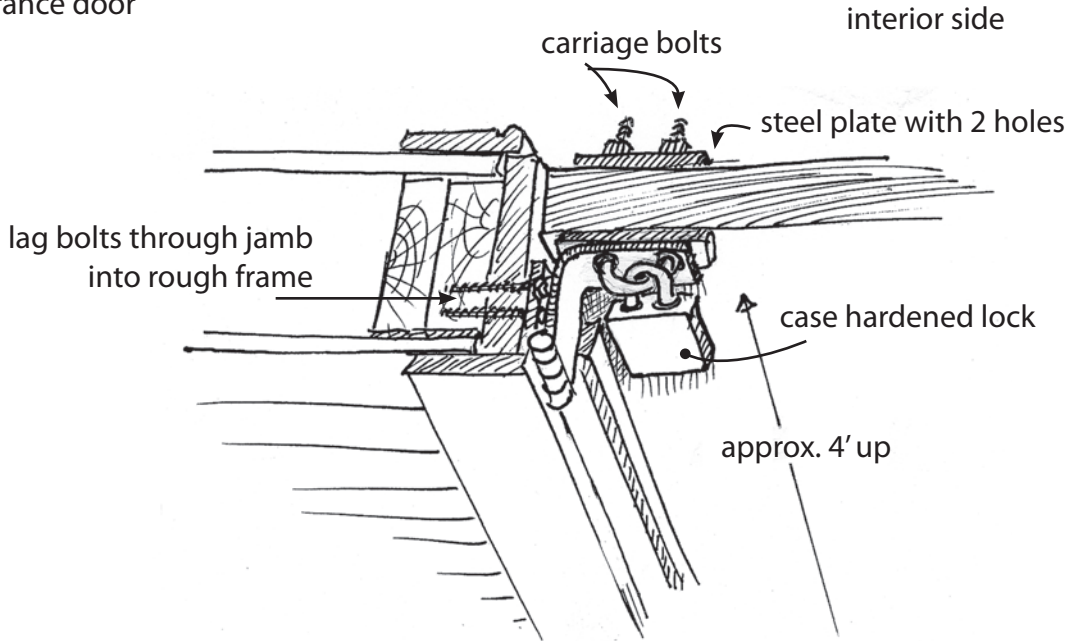

toolbox security

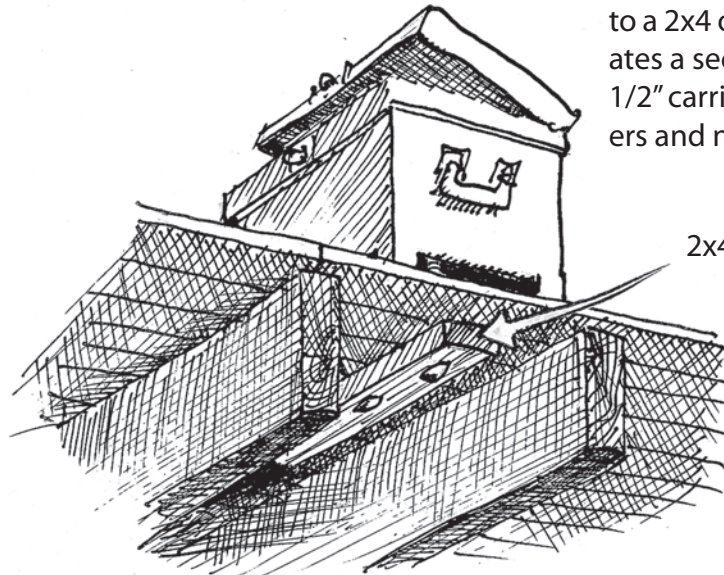

A steel strongbox bolted through floor to a 2x4 or metal plate under floor creates a secure place to store tools. Use 1/2" carriage bolts with fender washers and nuts inside the box.

2x4 or metal plate



## Clean and Treat

### Principles:

- Scrub and vacuum all surfaces.
- Wet clean all finished surfaces.
- Soak all structural surfaces with Termite Pruf (or similar) before closing in walls.

# Cleaning

During clean-up, wear an N100, R100 or P100 respirator, safety glasses, cap, and in wet areas wear water proof gloves and boots

After removing posesions, dry wall, insulation, sludg, and wall-to-wall carpet:

1. Using a scraper that attaches to a HEPA vac  or stiff scrub brush, scrape or scrub all finished surfaces. Place non-phosphate detergent in a mist or pump sprayer. Change rinse water frequently. Wring out rag or mop in seperate bucket or second side of a double bucket. Scrape first where there is heavy build-up of mold on structural surfaces, or old paint.



2. Once dry, vacuum all surfaces including electric outlet boxes and open ducts using a HEPA or high efficiency vacuum cleaner. A back-pac vacuum (for example, Pro-Team) is ideal for working off ladders, cleaning floors and crevices, and doing integrated pest management (IPM) work.

For small jobs carry a spray bottle containing detergent solution in a tool belt or apron Use a double bucket, one side for rinse water (change water frequently) and one side to ring out dirty water from string mop. A sponge mop will not work nearly as well.

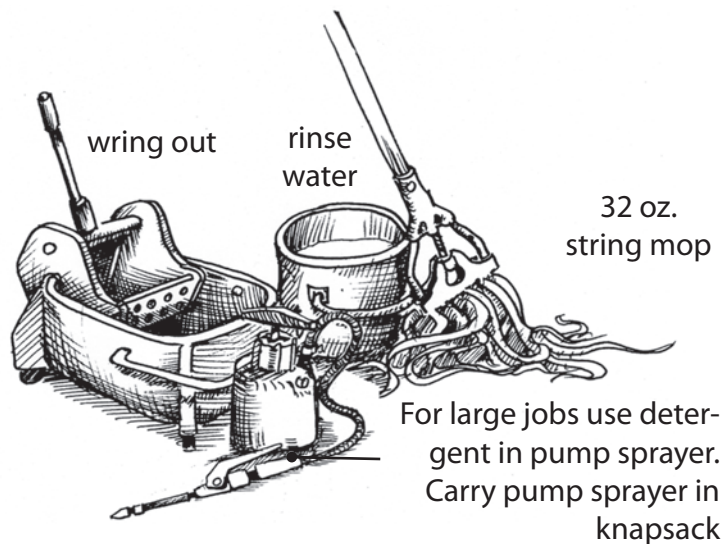
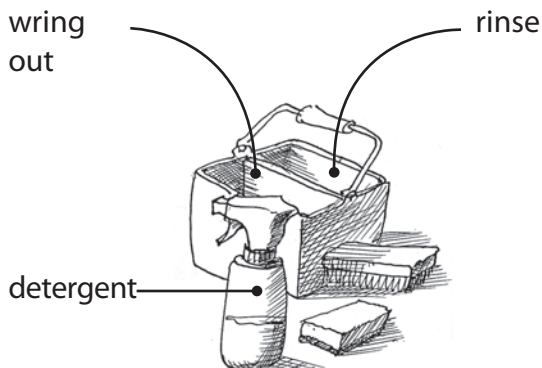

3. Mop the floors, changing rinse water frequently. Always air-dry mops and rags in the sun.

# Borate Treatment

1. Mix borate solution (for instance, Termite Pruf®) in pump or power sprayer reservoir. III

2. Soak wood, paying particular attention to the end-grain. Where necessary, pry studs away from plates, or joists from ribbon board (The boards located on the end of floor joists around the building's perimeter). Then squeeze tube into opening to soak end-grain. Allow to dry then apply second coat.

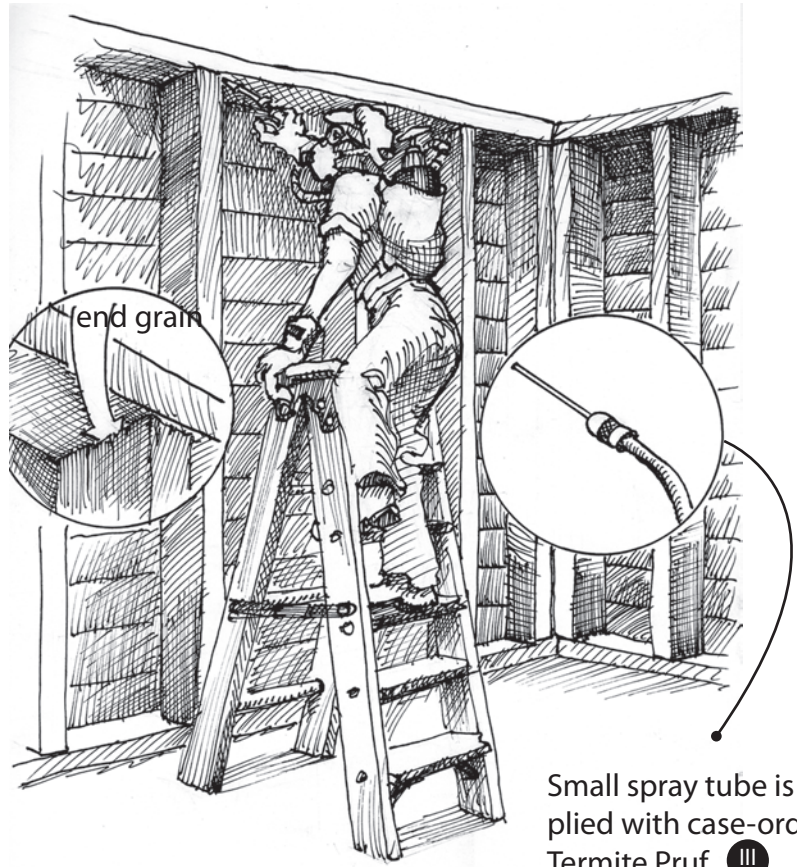
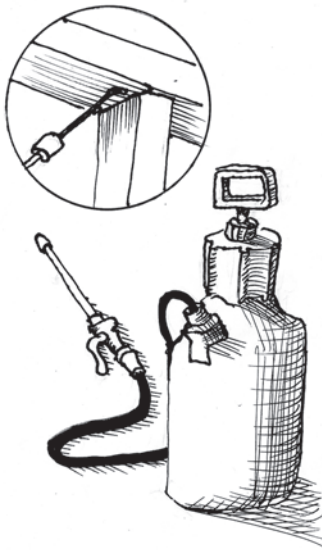

Small spray tube is supplied with case-order of Termite Pruf® III

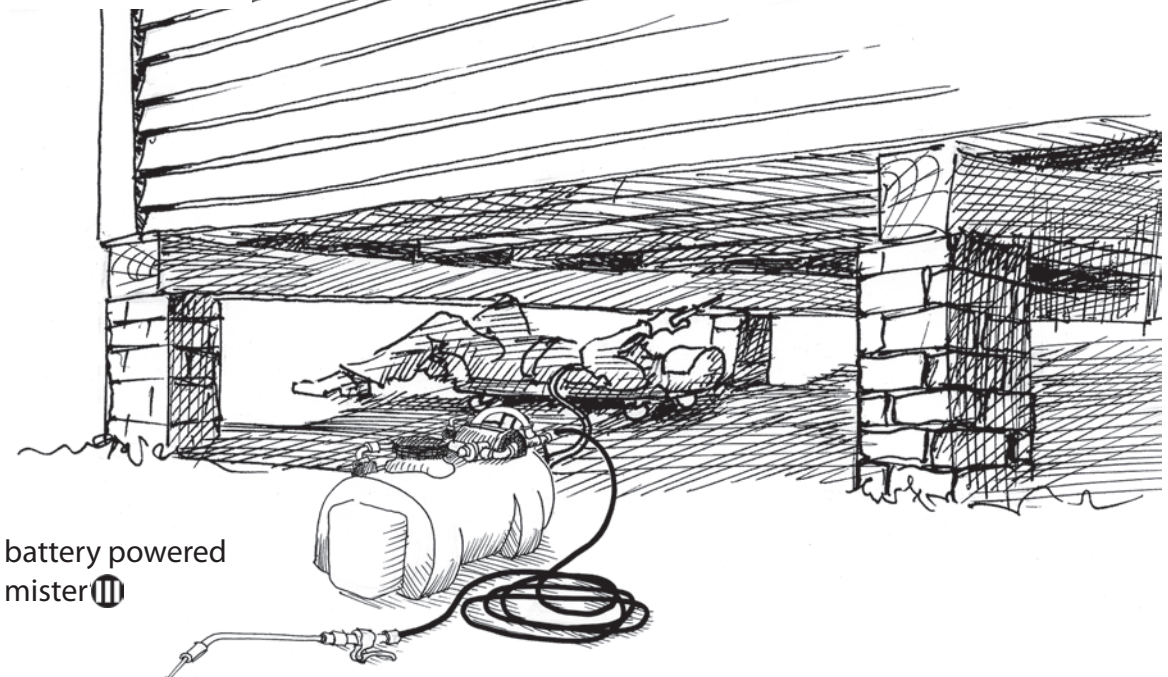

battery powered mister III

To access very tight space, use mechanic's creeper on sheets of plywood. Protect yourself with positive air hood respirator or welder's face shield.



## Creating a Clean-Room during Restoration

### Principles:

- Where possible, a clean-room has a separate entrance.
- Try to keep a fan running in "dirty space," pulling air from the clean-room.
- Clean the clean-room frequently.
- Do not wear dirty work clothes, especially shoes, into clean room.

# The Clean-Room

It's preferable to complete house renovation before anyone moves in. In some cases this may not be practical, as some people working on their house may not have another place to stay. In this instance it may be possible to renovate one or more rooms, isolate them from the rest of the house, and stay in them safely. It is critical that this clean-room has a direct and separate entrance from the exterior or an isolated passage through the work-space. It's too risky for children to live here.

Where the clean-room does not have running water, set up a portable toilet outside. Even if there is no running water, a sink can be used putting a 5 gallon bucket under the drain.

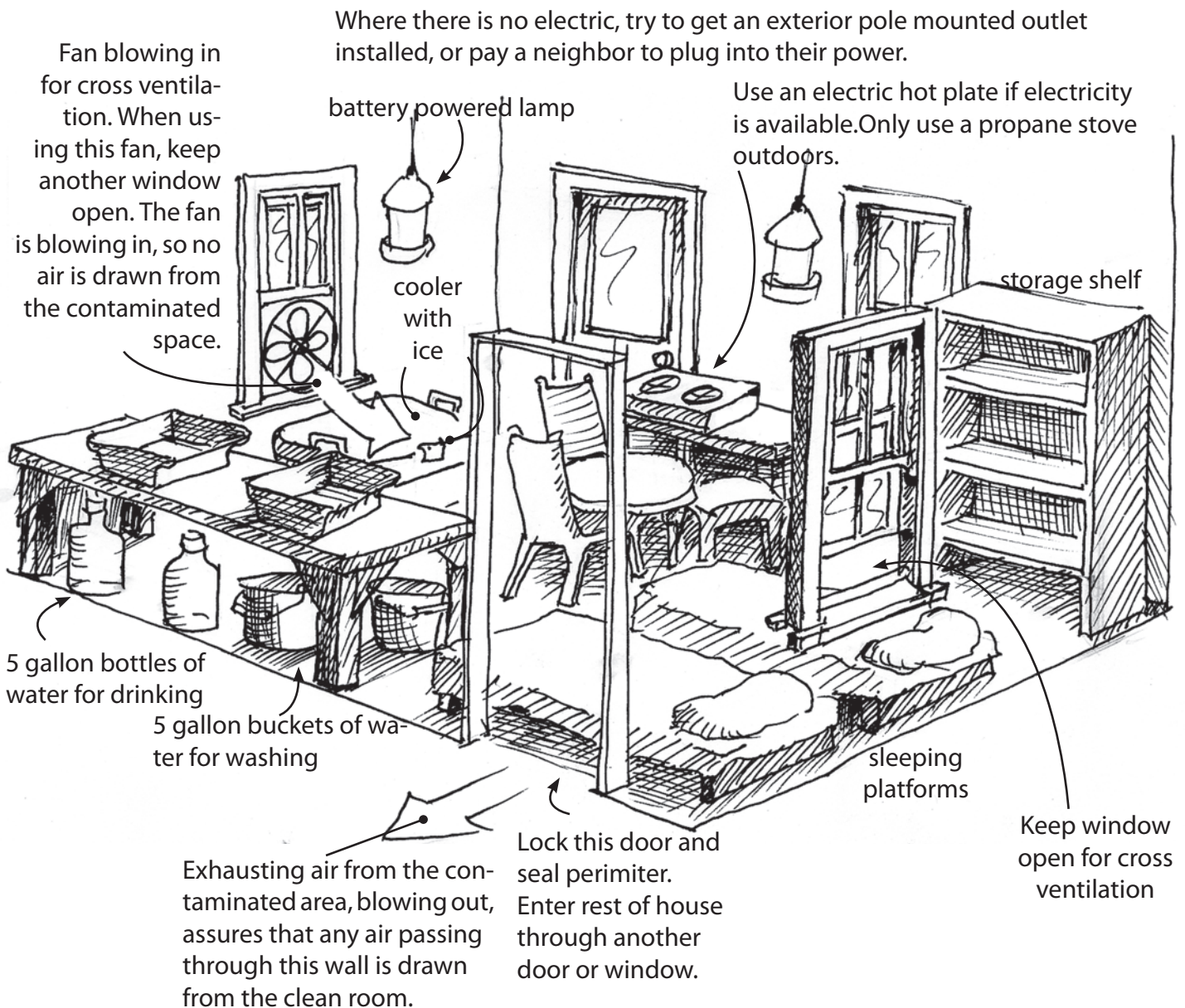

# Isolating Clean-Room(s)



If bathroom doesn't work, install a portable toilet outside.

If there is a working bathroom..

Use front or rear rooms as clean-rooms.  
Use the kitchen, particularly if kitchen drain works and room is large enough.

The safe room must be cleaned, treated, and completely isolated from the rest of the house. This includes caulking gaps in separating walls.

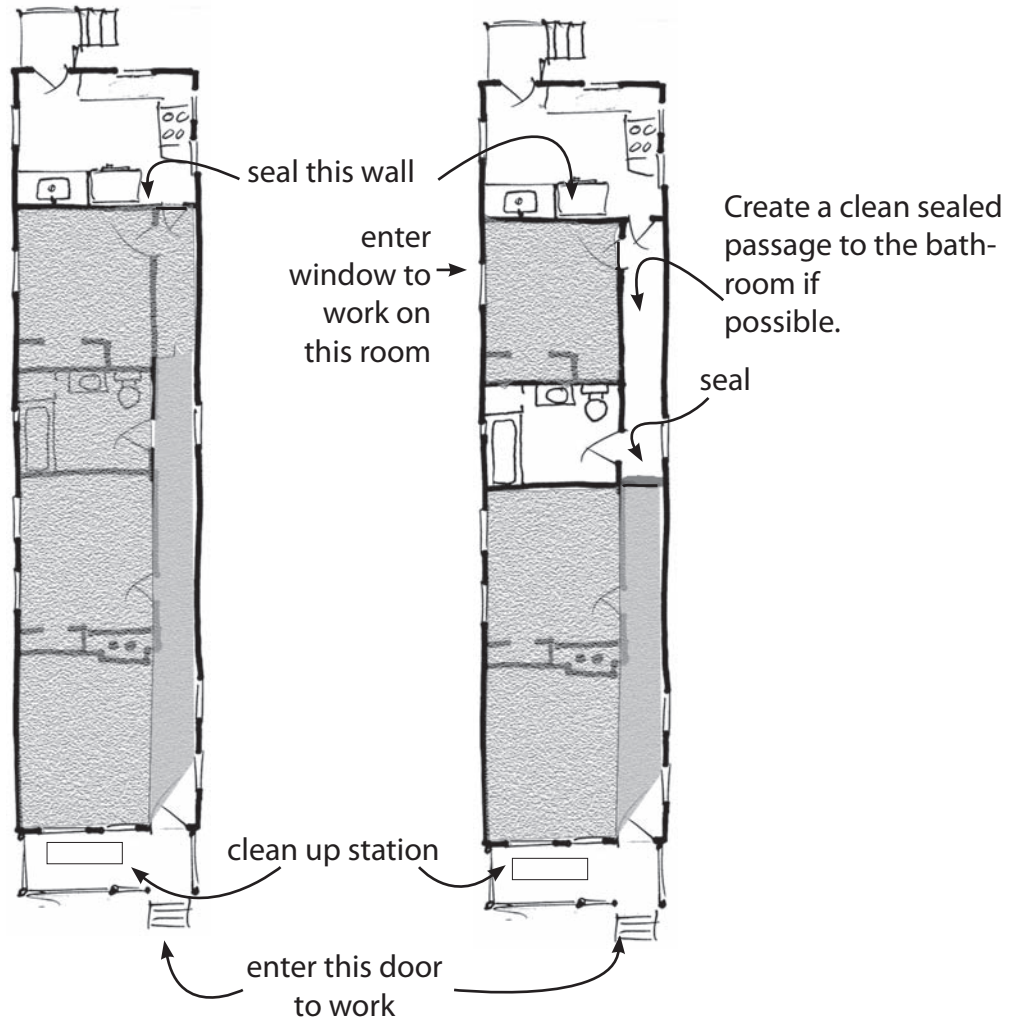

# Clean-Room In a Two Story House

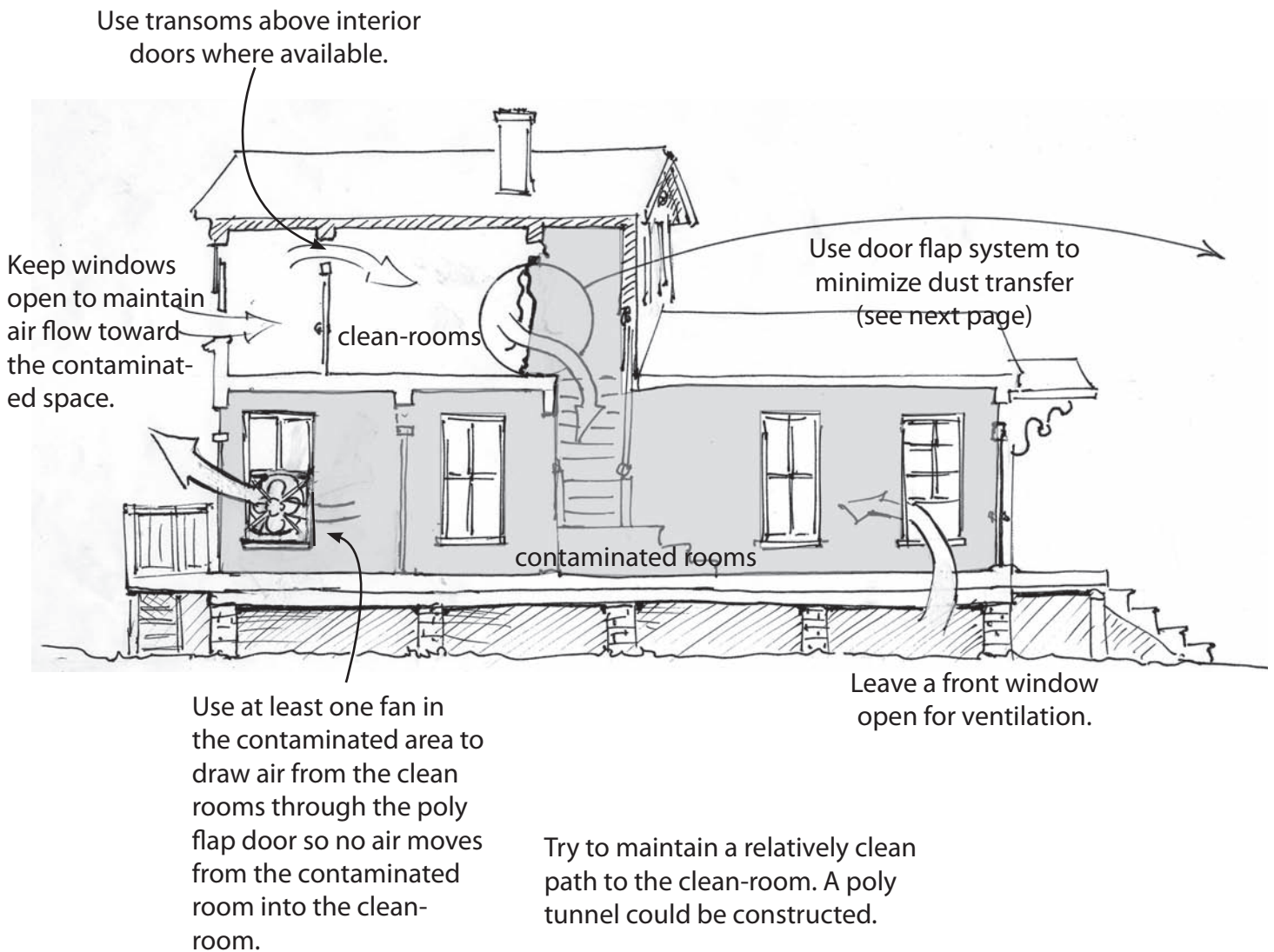

# Creating a Poly Flap Seal

Use this system in a door or other passage you need to use when you are trying to prevent dust from moving from a clean area to a dirty area, and when a separate exterior entrance is not practical.

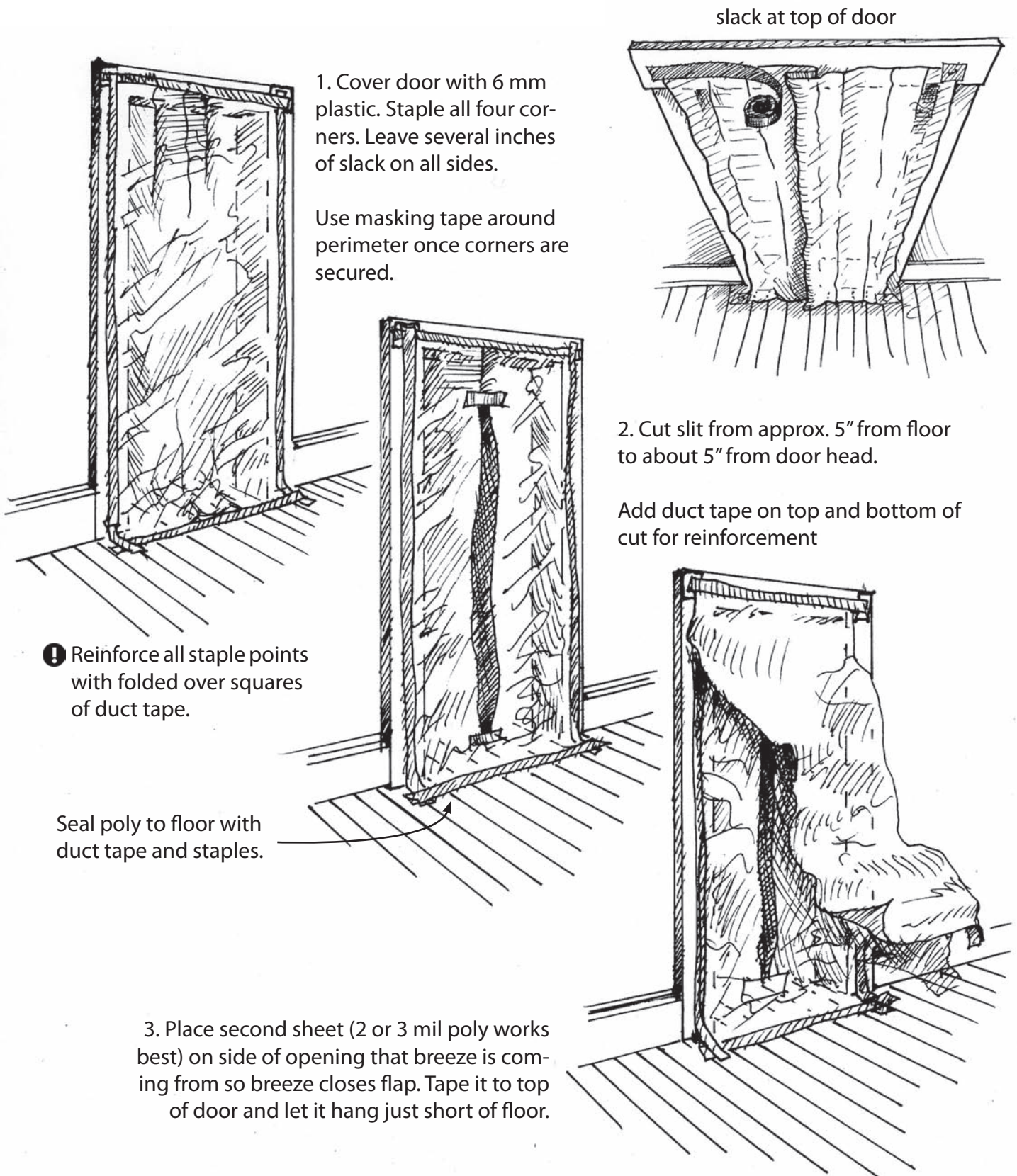



# Chapter 6

---

## Flood and Moisture Resistant Restoration

# Flood and Wind Resistance of Foundations

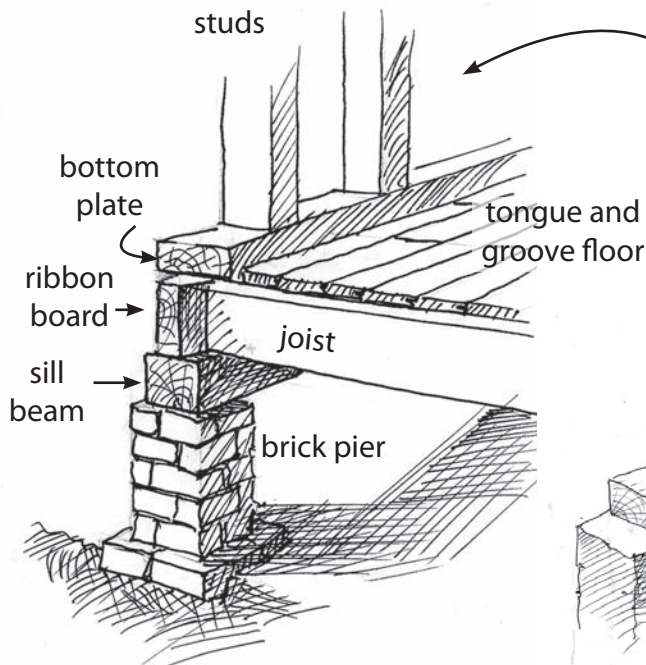

Traditional frame-on-pier construction drains and dries quickly, but the piers are extremely weak. The greatest risk is from high wind gusts or water surges. The piers also run the risk of uneven settling.

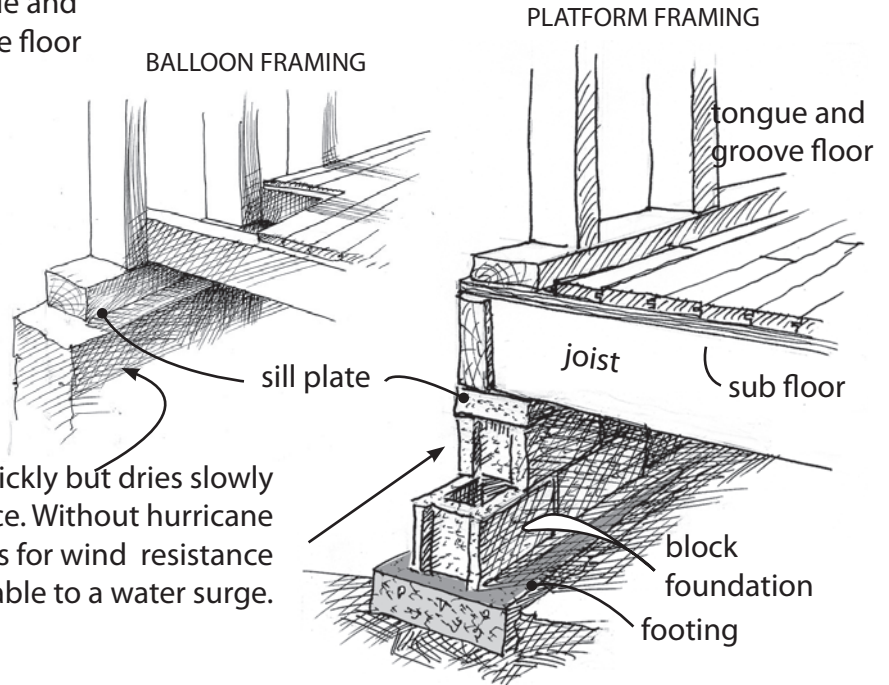

Frame-on-foundation wall drains quickly but dries slowly and can trap moisture in the crawl space. Without hurricane ties, it is not much stronger than piers for wind resistance and may be as vulnerable to a water surge.

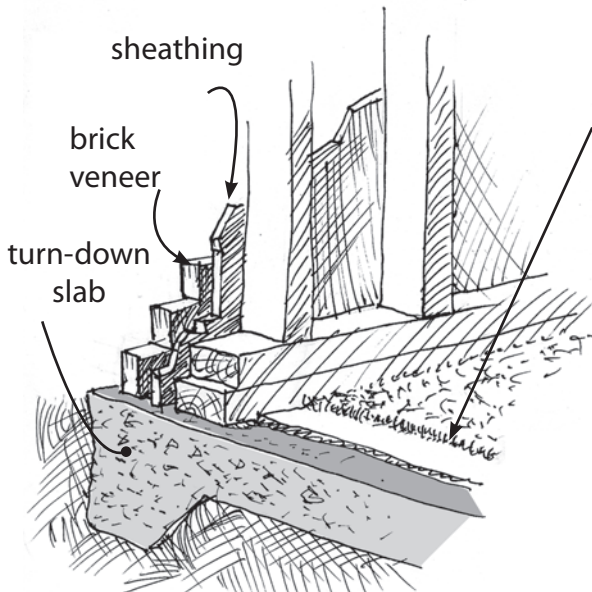

On-slab construction should always be avoided in low-lying land. It gets wet fastest and dries out slowest. Brick veneer walls trap moisture. Any material put on the slab runs the risk of absorbing moisture, becoming moldy, and rotting.

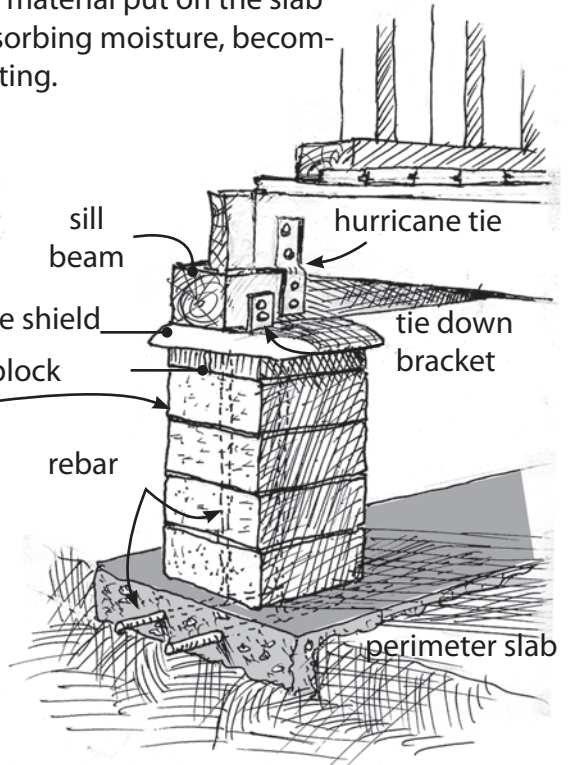

Reinforced perimeter slab or footing having rebar integral with rebar enforced concrete-filled I-vary block piers is a very stable foundation. This secures the house to the ground and allows flood surge to pass under. It still needs hurricane ties from sill beam to floor joists, floor joists to wall plate, wall plate to studs, etc. Always install a termite / moisture barrier between pier and sill beam.

# Flood Resistant Design

Maintain a safety station in the attic, second floor, or easily accessible place above flood line with the following equipment:

- first aid kit
- sealed glass containers of drinking water
- preserved emergency food
- flashlight on constant charge and/or extra batteries
- a battery powered lantern
- waterproof gloves and wading boots
- N100, R100 or P100 respirators and safety glasses
- battery operated generator
- cell phone
- small generator for running fans and dehumidifiers as soon as water recedes (run generator outdoors on the roof)

Where flood water came to less than 4 feet up wall, and it isn't possible to elevate the building above possible flood hazard, consider restoring it with flood resistant materials, elevated wiring, and emergency equipment, supplies, and shelter.

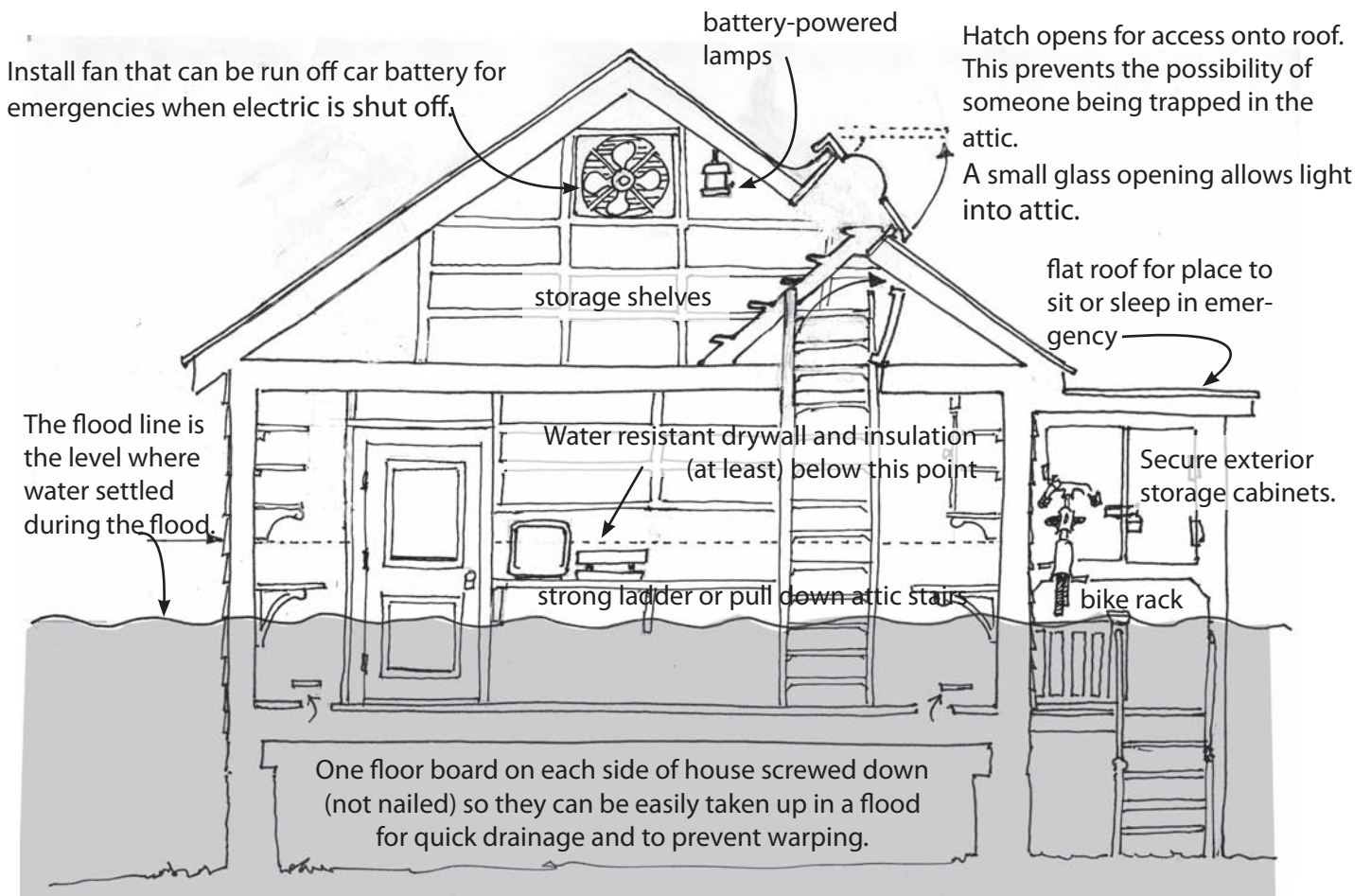

# Flood-Resistant Dry Wall Design

Where potential flood depth is less than three feet, use paperless, moisture resistant dry wall or removable wainscoting at least on bottom of wall.

Where possible, use same profile moulding as original.

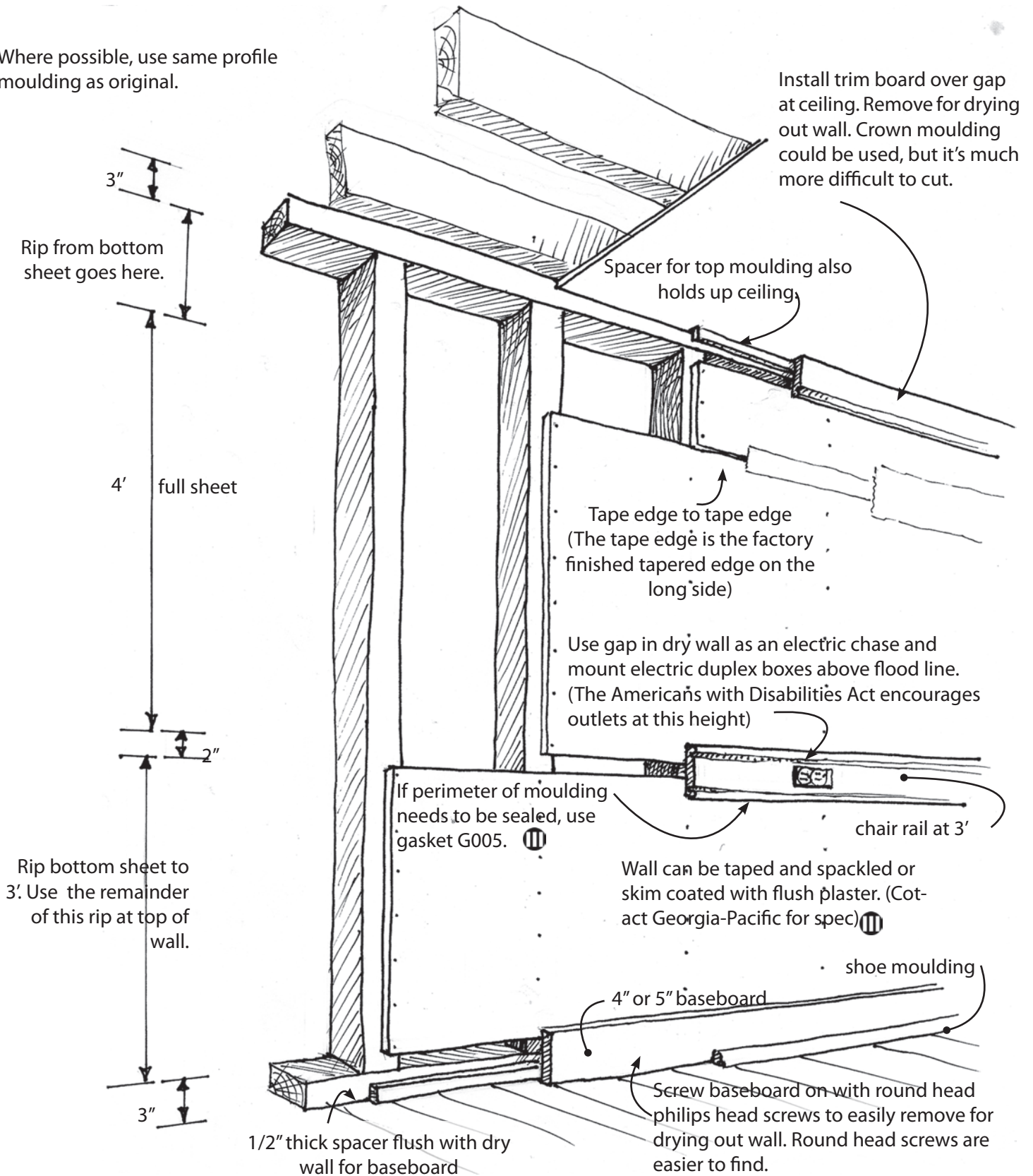

# Flood Resistant Kitchen Storage

- Build open, solid-wood shelves or other water resistant material for base cabinets.
- Store items that won't be damaged by flood waters on bottom shelves (bowls, pots, pails, etc.) and items like detergents that can be easily replaced.
- Open shelves make it easier to keep stored items dry, pest free, ventilated, more easily accessible, and easier to clean.
- A pantry can provide a large amount of easily accessible shelf space above the flood line.
- Locate counter-top stove, oven, and microwave units above the flood line.

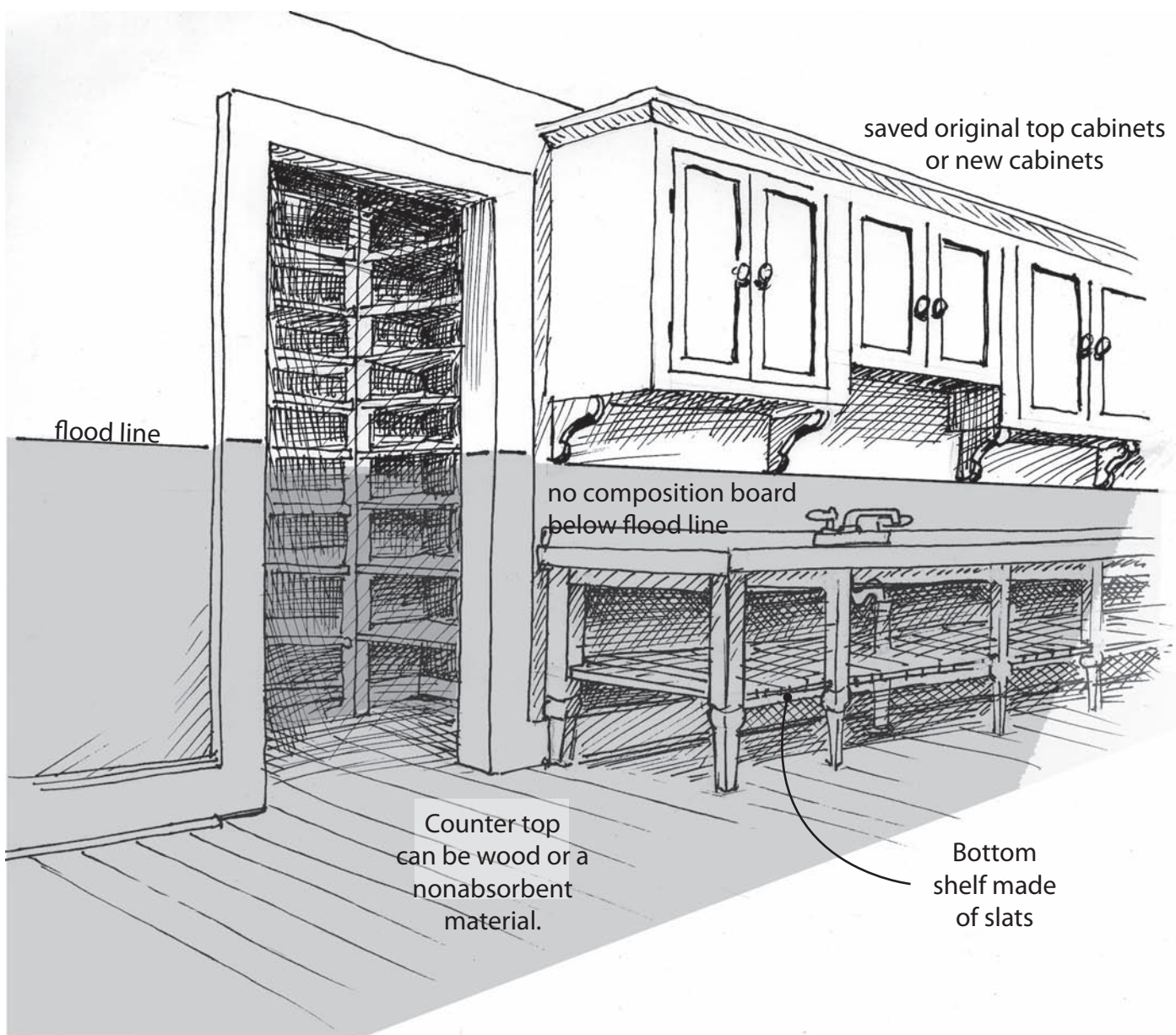



## The House as a System

### Principle:

To control water, temperature, and air, we must understand how they interact within the house's environment.

# How Water Enters and Moves through a House:

Uncontrolled water and water vapor are the major cause of:

- wood rot
- mold growth
- lead paint failure
- rust

- and contribute to:
- roach infestation
  - dust mite growth
  - foundation failure

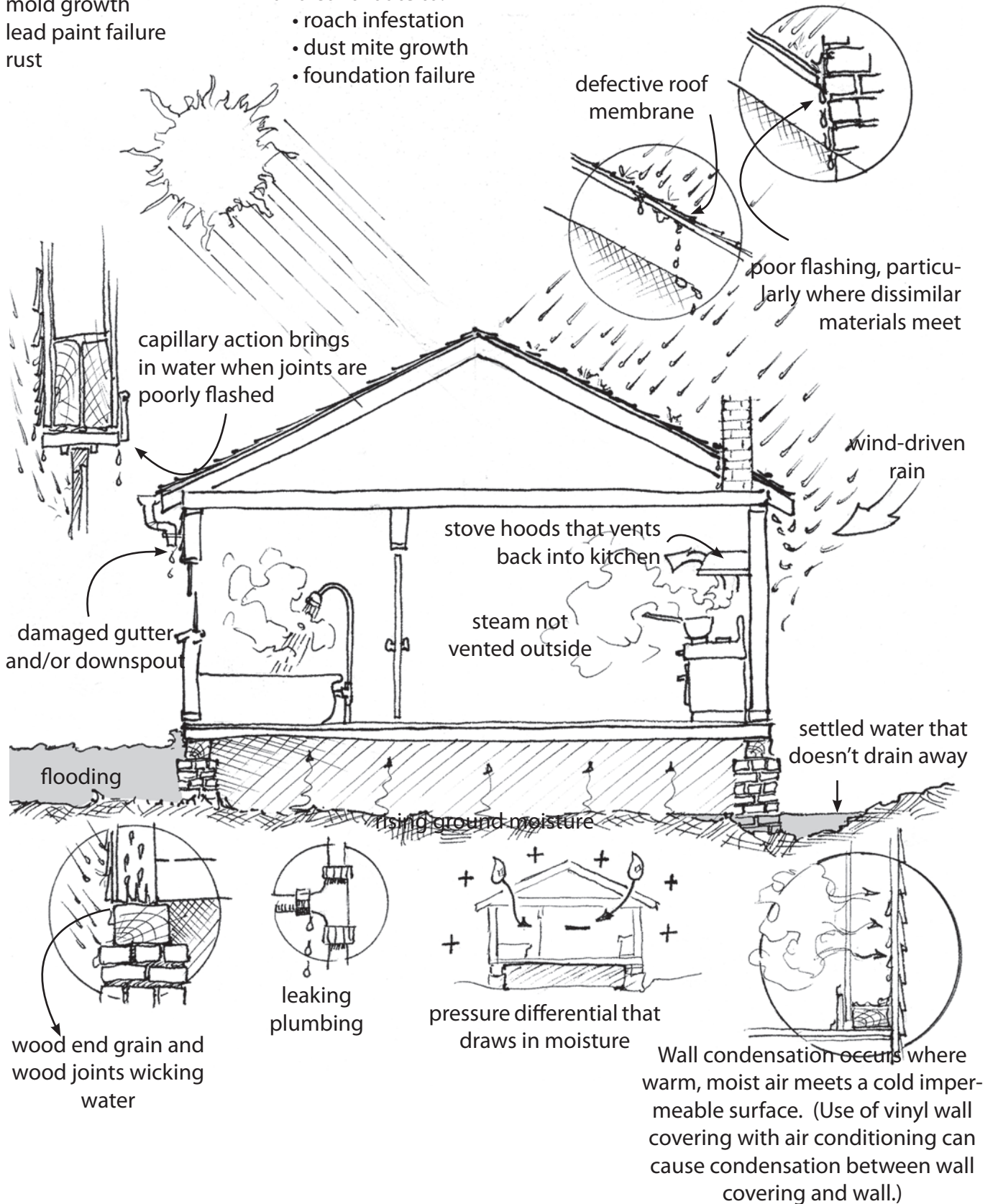

We want to:  
SHED water away  
BLOCK water from entering  
DRAIN out what has entered  
DRY what gets wet  
.....using

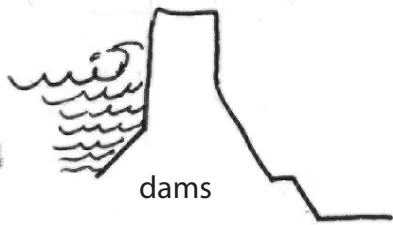

dams



seals

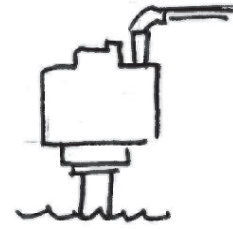

pumps

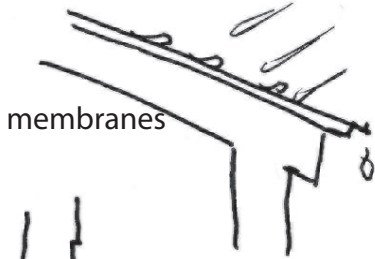

membranes



ventilation

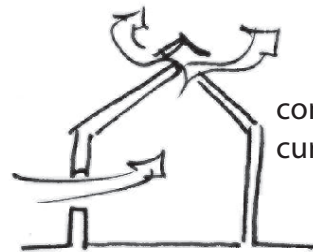

convection currents



flashing

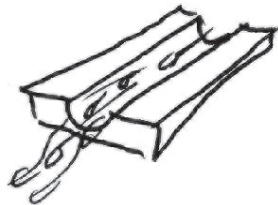

channels

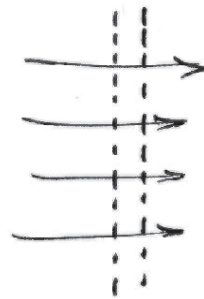

permeable interior membranes



vapor retarders

# Flashing

Install flashing correctly to seal horizontal gap on outside

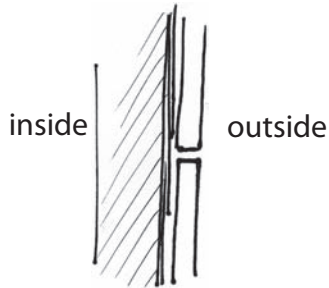

From least effective to most effective

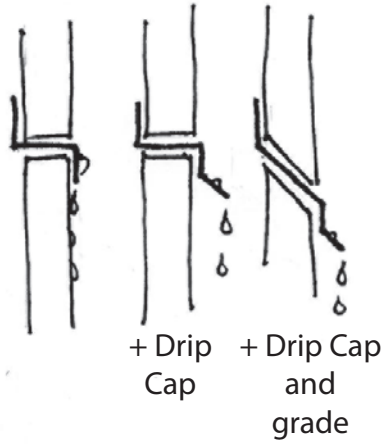

## Traditional wood flashing

### Copper flashing

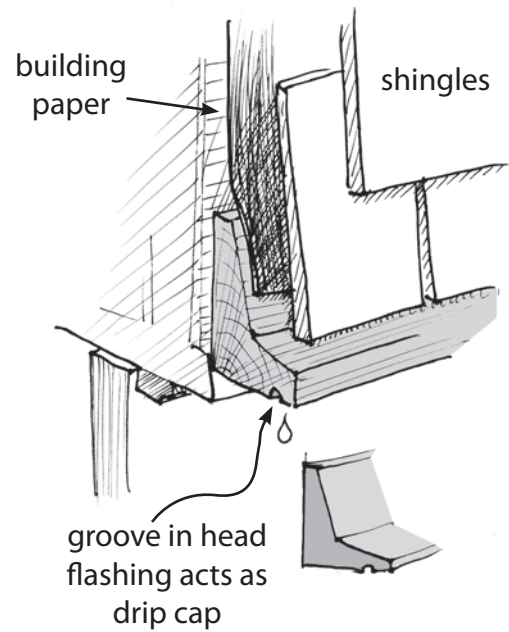
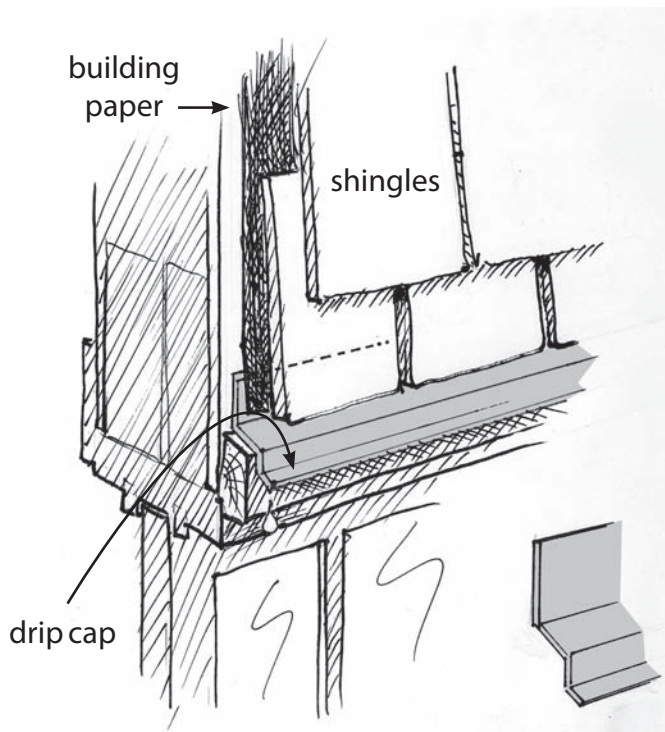

# Roof Flashing

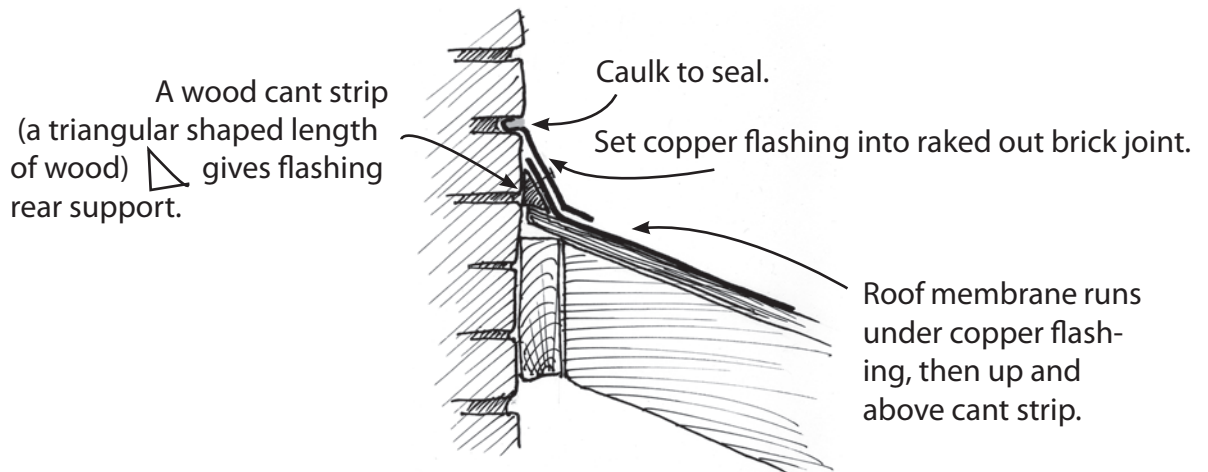
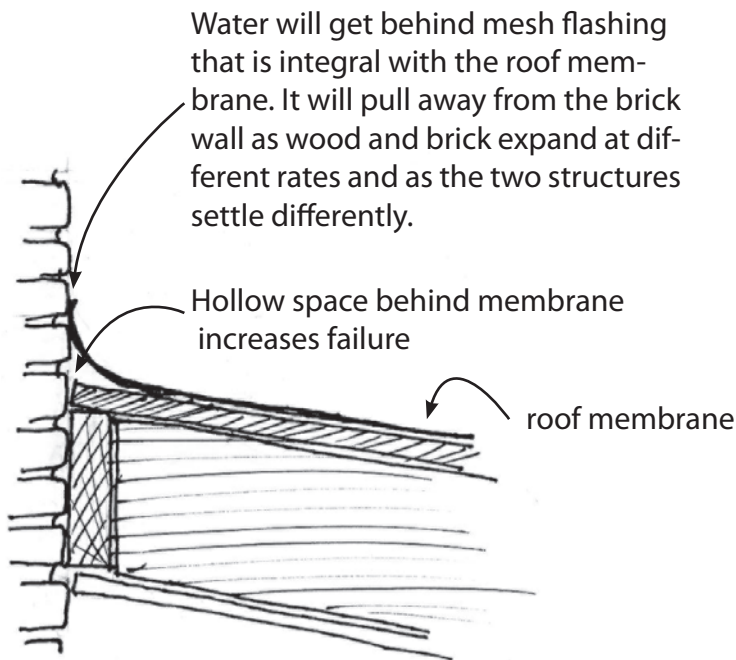

Copper flashing and roof membrane are not adhered to each other so they can move independently as adjacent structures move at different rates.

# Insulation Strategies

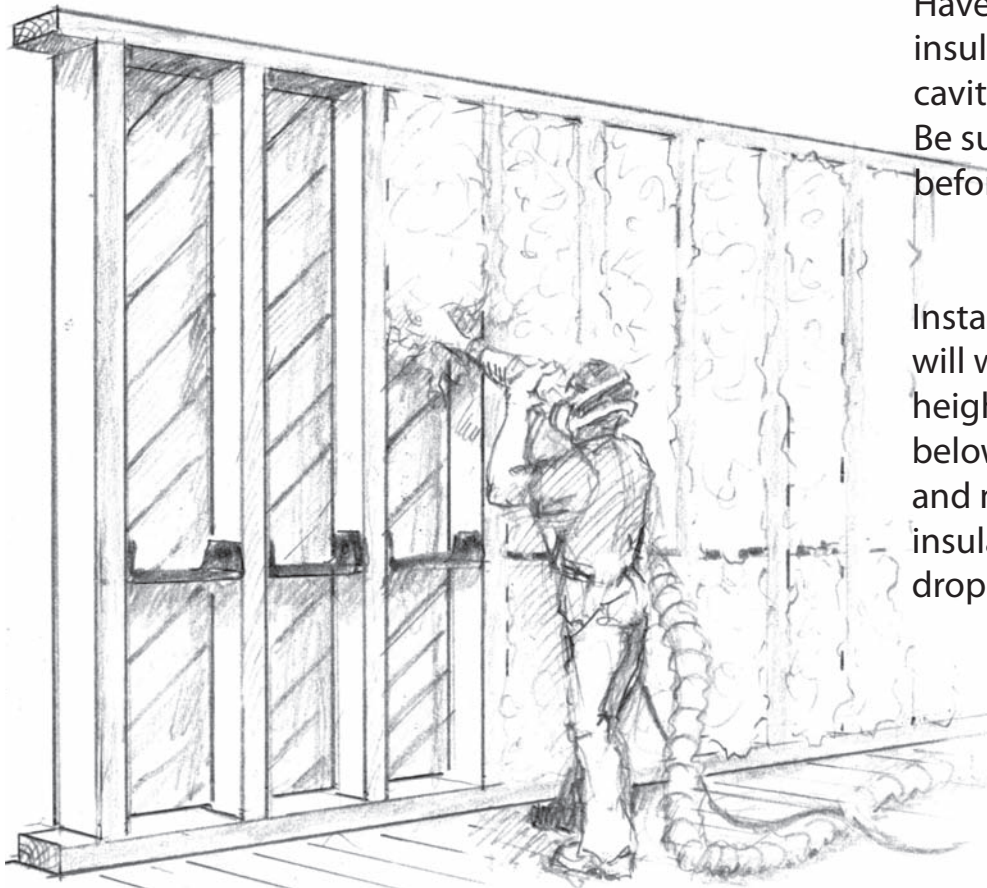

Have cellulose spray-in-place insulation installed in all wall cavities after electric is run. Be sure insulation is fully dry before closing in wall.

Install a barrier (building paper will work) at the chair rail height so that if the insulation below the chair rail gets wet and needs to be replaced, the insulation above it does not drop down.

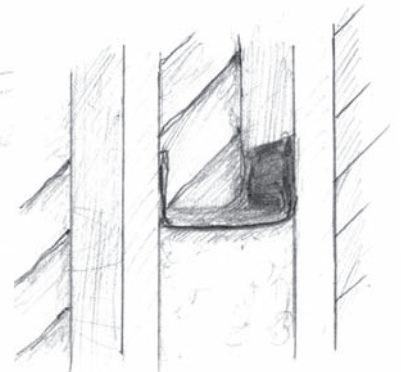

To install loose fill insulation in a wall using an insulation blower, or installed by hand:

Install bottom row of paperless dry wall and fill cavity, making sure there are no voids.

Then install a barrier at chair rail. Install the next row of drywall and fill the void from above.

Leave a gap between the wall's top plate and the top of the last sheet to fill the top of the wall cavity with insulation

This space is covered by a trim board or crown moulding.

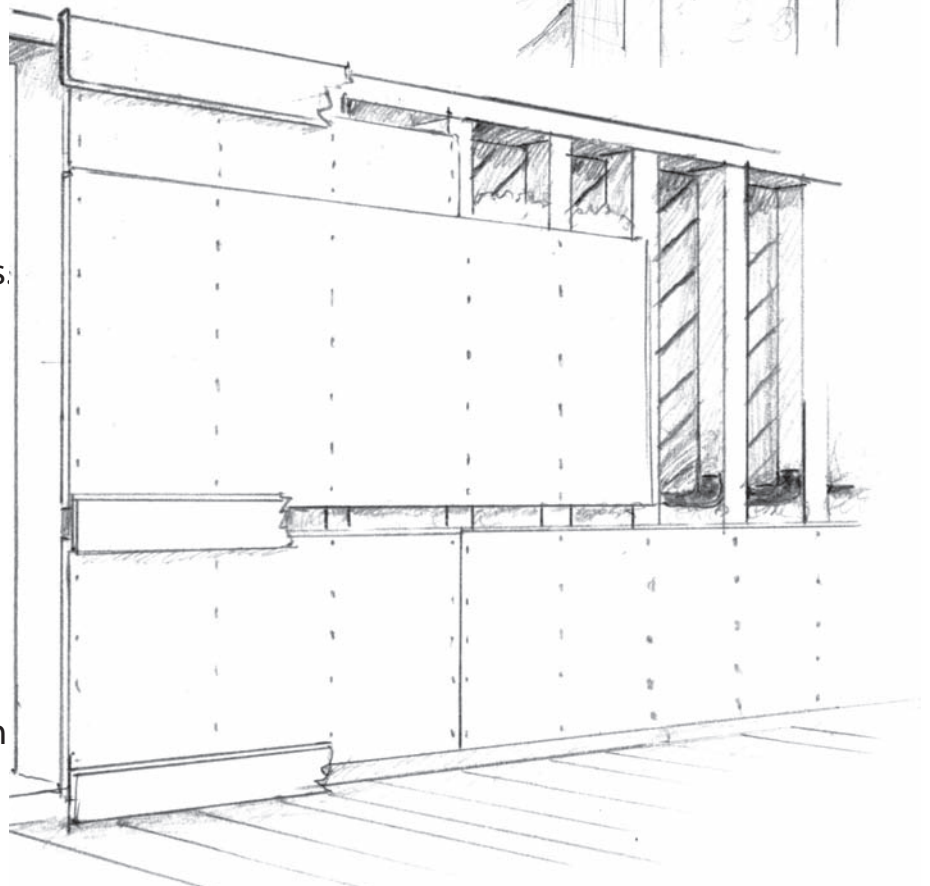

Where the roof has soffit vents, install collar ties and gable end vents above the collar ties at both ends. Install continuous sheets of 2 inch Thermax (or equivalent) under rafters and collar ties. If there is a roof vent, the gable end vents are not necessary.

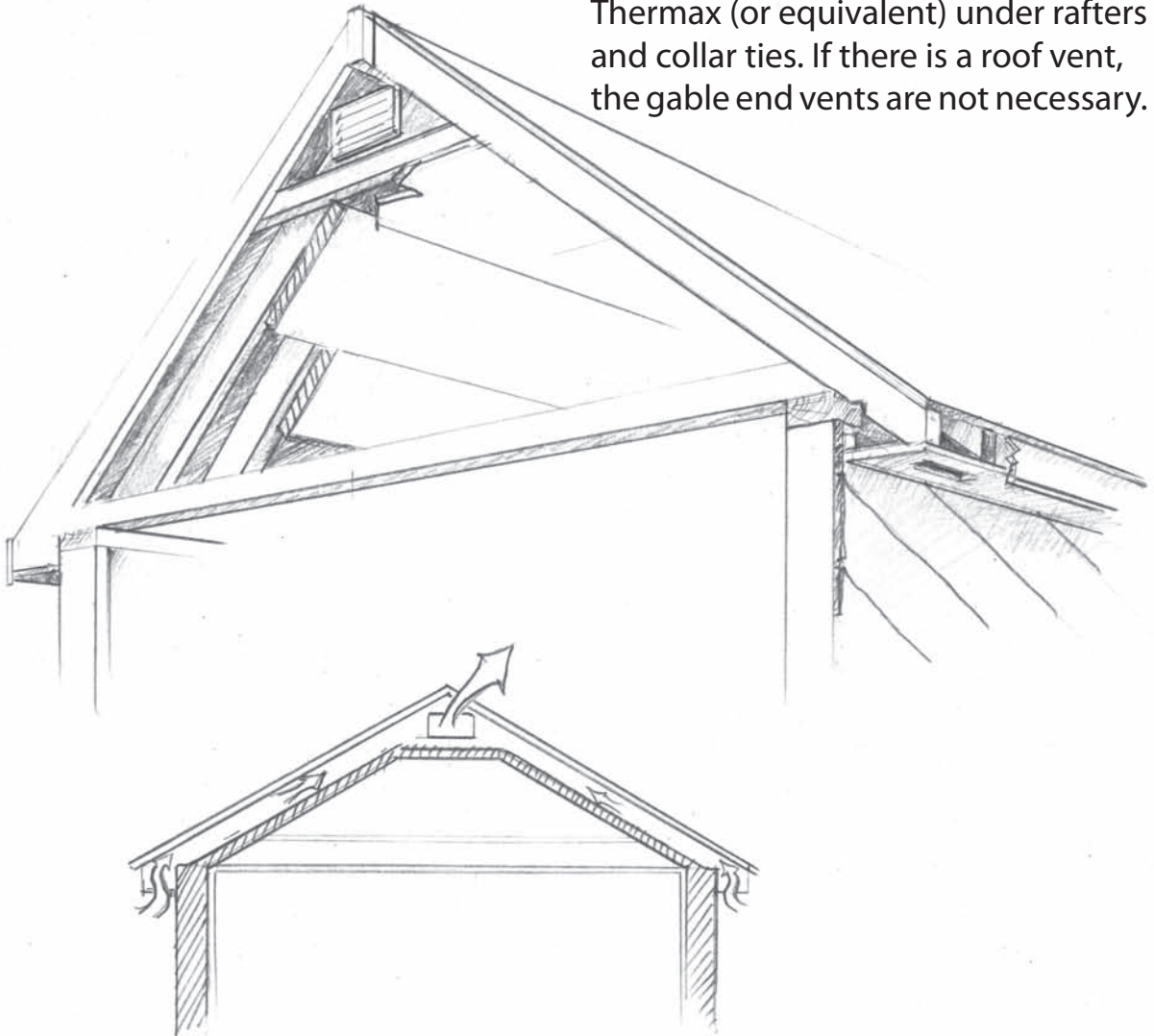

This allows a continuous flow of air between the Thermax and the roof surface.



## Green, Lead Safe Restoration

Note: Effective April 22, 2010, new federal rules apply to most work done in pre-1978 homes when painted surfaces are disturbed. Under EPA's lead-safe remodeling, repair and painting (RRP) rule, every contractor working for compensation must be an EPA-certified renovation firm and every job must have a trained and certified renovator assigned to it. The new rule prohibits several unsafe work practices (open-flame burning of paint, use of heat guns above 1,100 degrees Fahrenheit, and use of high-speed mechanical paint removal methods without a HEPA filtered exhaust). The rule also requires containment of the work area (plastic sheeting on the floor or ground and sealing of doors, windows and HVAC vents near the work area, and the posting of warning signs to keep non-workers out of the work area), work area cleanup and verification of cleanliness. For more information, see [www.epa.gov/lead/pubs/renovation.htm](http://www.epa.gov/lead/pubs/renovation.htm).

# Saving a Plaster Wall

If wall is insulated with water absorbant insulation, remove about 5 inches of plaster at top and bottom of wall so if there's another flood, the baseboard and top moulding can be removed to remove insulation and dry the wall.

Install gasket around perimeter of boards. Use round-head screws every 6' so screws can be easily found if board needs to be removed for drainage or dry out.

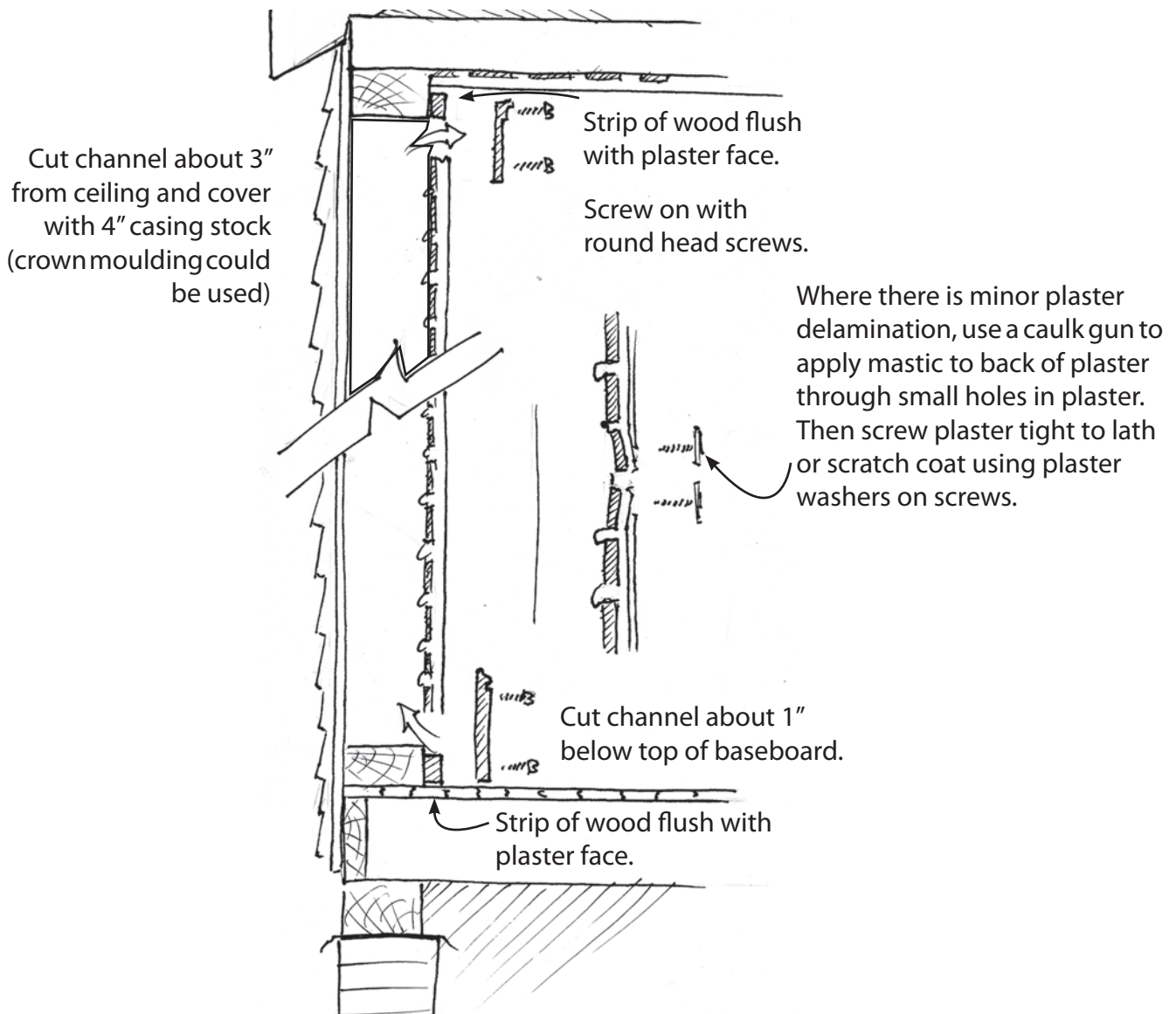

# Plaster Surface Repair

For plaster walls that are well attached to lath and dried out, but have cracking and surface damage:

1 Fill holes with joint compound to create flush surface.

(If wall surfaces is very porous it will cause the base coat to dry before proper adhesion of the mesh. To prevent this coat the wall with primer or seize first)

2 Cut sheet of Nu-Wal (or equivalent) a few inches too long to lap over baseboard and ceiling.

3 Roll generous amount of Nu-Wal liquid over area that Nu-Wal mesh will cover. Use high nap roller. Work fast as mesh won't adhere to drying liquid.

4 Press sheet into liquid. A wallpaper brush or gloved hand can be used.

5 Never run full sheet around inside or outside corners. Cut approx. 6" strip and run 3" on both sides. then overlap full sheet by about 1".

9 Press broad spackle knife into corner of wall at baseboard and ceiling. Run utility knife along blade.

10 Finish with one coat of latex paint. Do not use vinyl wallpaper or oil based paint.

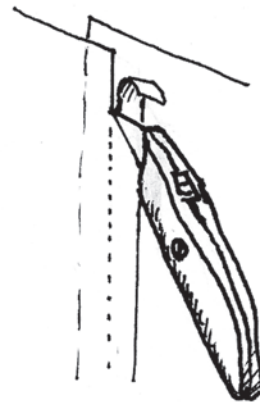

6 Overlap full sheet about 1" and cut down center of overlap.

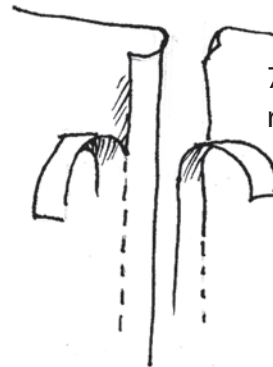

7 Open top sheet and remove both cut pieces.

8 Close back up. The two sheets should butt against each other, creating an invisible seam.



11 If baseboard or cap moulding will be added, set mesh behind them.

The NuWal 2035 coating has a perm rate of 3.5. It is important that interior wall surfaces are vapor permeable.

# Lead Safe Window Restoration

Where there is a counter weight system, re-hang at least the bottom sash on chain.

Replace inside stop with weatherstrip stop (see page 70) III

Wet scraping inside face of parting bead and removing paint from the sash outside face eliminates friction on lead-painted surfaces.

Install weatherstripping that seals the bottom sash from infiltration. III

If it's a pre-1950 house, the windows are probably lead painted. Lead paint was sold until 1978. If you are making or leaving top sash fixed, remove built-up and peeling paint and repaint using the most adhesive primer and best grade of latex top coat. Bring the bottom sash in and remove all exterior and edge paint. Repaint and reglaze as necessary.

Remove all the paint from at least the nose of the stool, better still from the entire stool

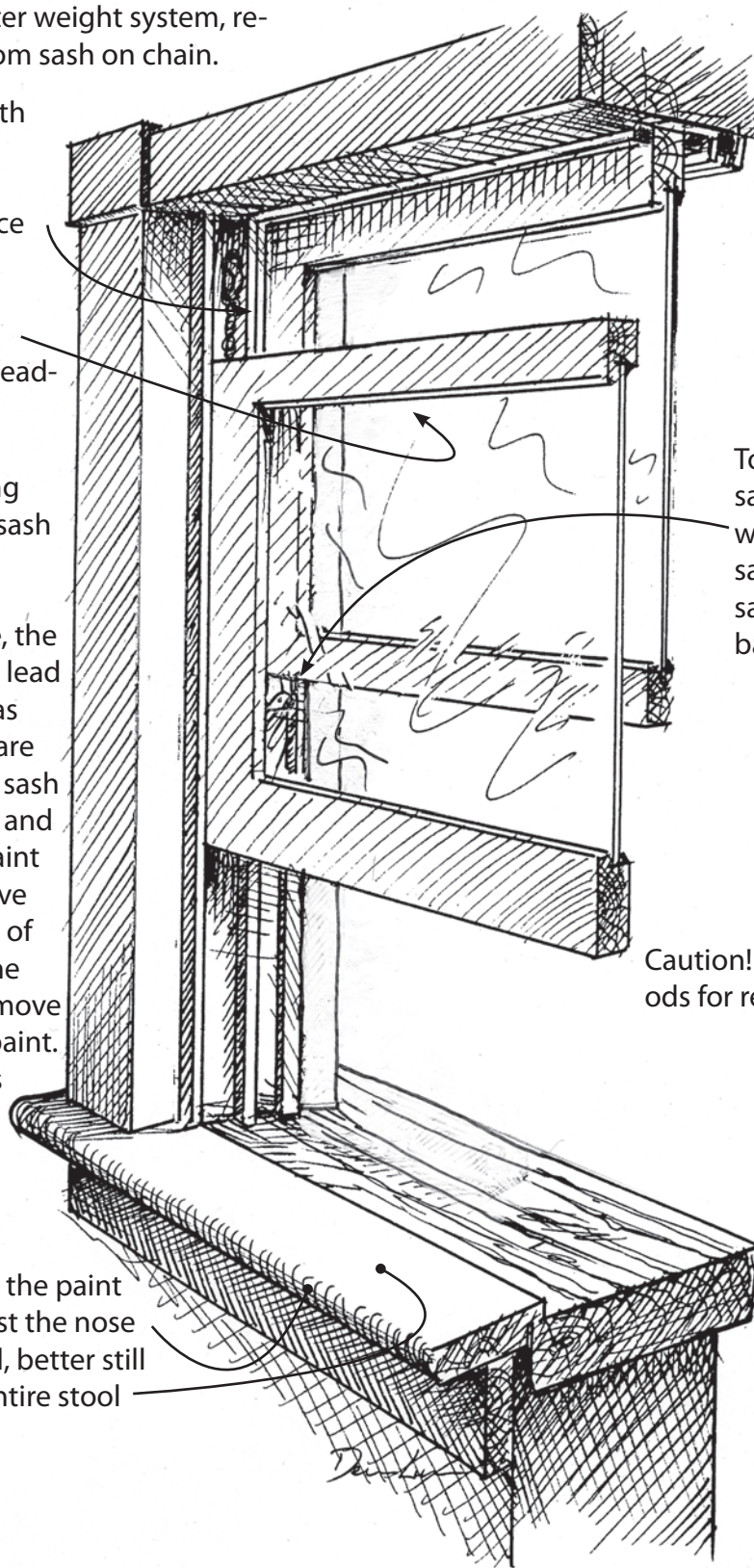

To save money, fix the top sash in place by screwing wood blocks under the top sash stiles. Make one top sash operable in the bathroom and kitchen.

Caution! See page 74 for safe methods for removing lead paint.

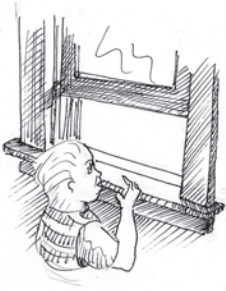

The rounded nose of a window stool sticks out at the height of a child's mouth where children often play. Children can be exposed to lead by chewing on this lead-painted surface. But more importantly this surface tends to degrade because of exposure to dampness and accumulated lead dust.

Remove all paint from the nose of the stool using a hand plane or by wet scraping. The outside sill and jamb also degrade because of sun and rain. It is critical the old paint is well maintained, otherwise window stools should be stripped and repainted.

If you live in a home built before 1978 and have children, test to see if you have lead in deteriorated paint or lead dust hazards. Lead dust and paint chip collection kits are available to do this test yourself. **III**  
 A professional risk assessment is more reliable but far more expensive.

While some children actually eat lead paint chips, children more commonly become lead poisoned because failed lead paint turns to dust and children put their sticky hands, toys, teething rings, etc. into the dust, then in their mouths. Keep paint sound and mop or vacuum frequently. Intact lead paint is rarely a health hazard.

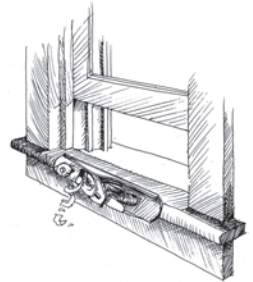

## Window Safety

If you can't restore the counter weight system to working order, or are dealing with a window without one, install a safe way to hold it open.

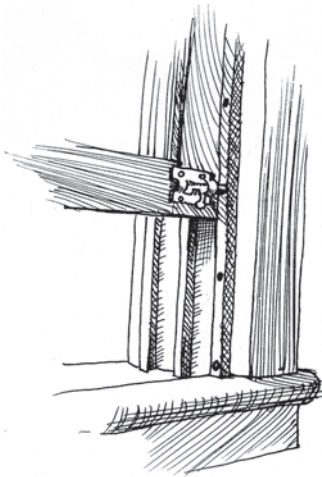

One option is to attach slide bolt on the bottom of the sash. Then mark three or four spots on the inside stop by tapping the bolt with a hammer. Drill holes slightly larger than the bolt at the marks .

There are some spring holders designed to hold open the sash.

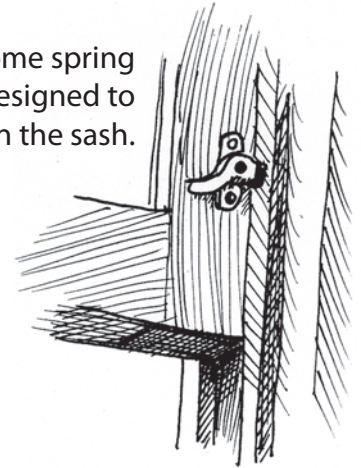

Spring clips that are screwed to the jamb.

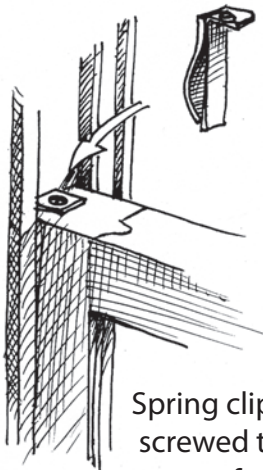
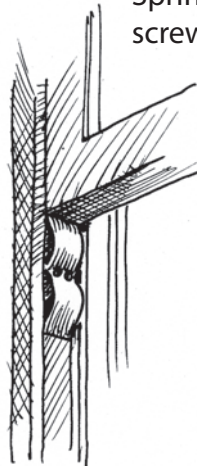

Spring clips that are screwed to the top of sash.

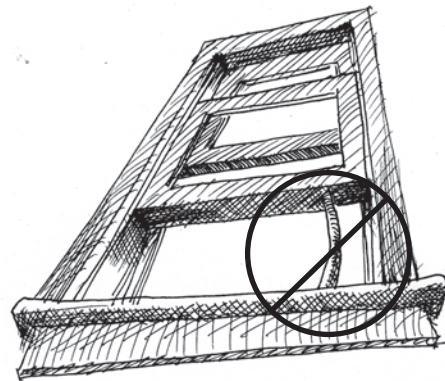

...but NEVER leave the window so it needs a stick to hold it open. This is a child guillotine.

# Weather-Stripping Double Hung Windows

An effective, long-life method for weather-stripping a double hung window is to install a nylon brush seal into a kerf-cut in the inside stop. The kerf can be cut on a router table using a WS90 router blade from Resources Conservation Technology (RCT) or equivalent. **III** You can order inside stop already cut from RCT or a local mill can cut the kerf into inside stop stock. The width must be exactly 1/8". Use a piece of weather-stripping to test the first cut.

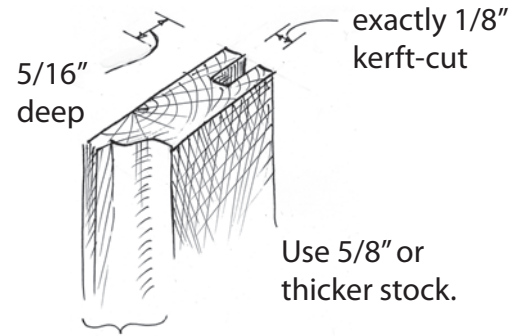

Any molding profile works.

For best results purchase rounter blade designed for this kerf where you purchase the weatherstripping

Install a nylon brush seal into the kerf and a rubber gasket between the stop and the window jamb to seal. Both can be ordered from RCT or other suppliers. **III** Drill oval holes through stop and screw through a finish washer into the jamb. This design allows you to loosen the screw and adjust the amount of pressure the brush is exerting against the face of the sash.

If you are reglazing a window, always bed the glass in latex acrylics caulk. For bedding glazing that remains more elastic, and therefore more effective, order Glaze Ease elastomeric glazing from RCT (or equivalent).

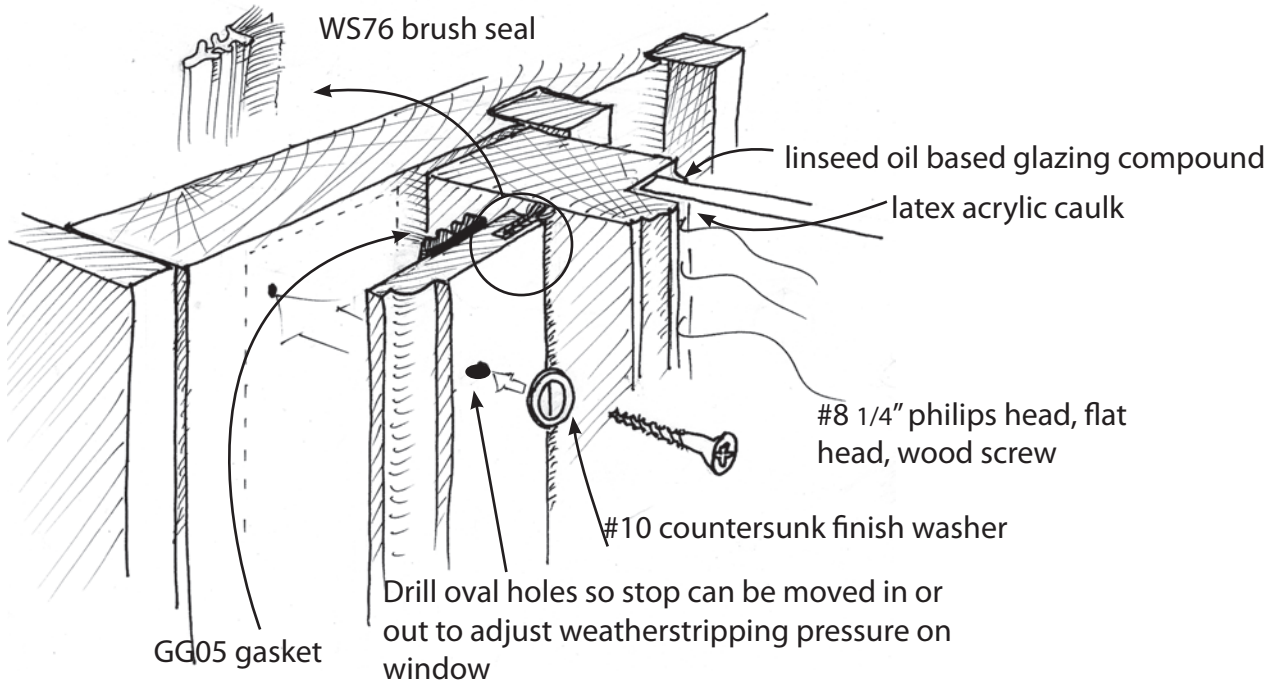

# Counter Weight System Repair

There is no more long lasting counterweight system than weights on chains. If the sash is on a rope you may want to replace it with a chain. If it's already on a chain, pull the chain down and insert a nail through a link of the chain near the pulley so the chain is not lost into the weight compartment when the sash is detached. To replace a rope with chain, or replace a missing chain before it breaks, follow the steps listed below. Purchase chain designed as sash chain.

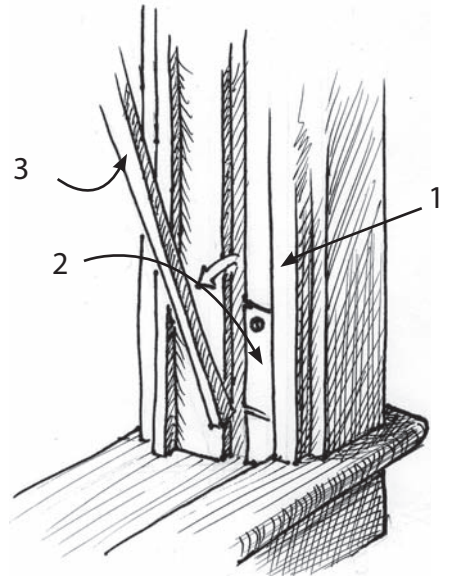

These instructions are for re-hanging the bottom sash and sealing the top sash in place. This saves money. Ideally one bathroom and kitchen window would have one top sash operative.

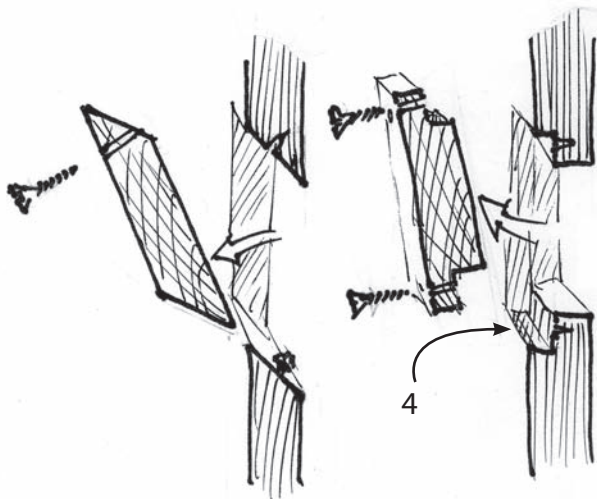

1 Remove inside stop. Replacing it with a new sash removes a lead paint friction surface and gives you the opportunity to install an inside stop with weatherstripping. (see page 70)

2 Look for the screw that holds the access door closed. You may need to scrape away paint. If there is no access door, you will need to remove the casing or cut a new door using a jig saw or saber saw.

3 You may need to cut the parting bead just below the top sash and remove it. This can be scraped and reused.

4 Some doors are only partially cut and may need to be pried off.

5 Reach into weight compartment and remove weight. If you aren't re-hanging top sash, leave its weight inside the compartment, pushed to the outside wall of compartment.

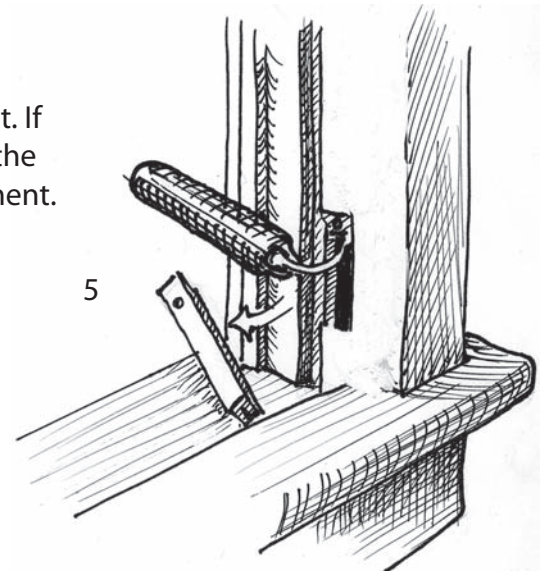

6 Pass chain over pulley (don't cut to length yet). Reach into weight compartment and pull out chain. Thread chain through eye of weight and wire chain to chain. (Use fixture if it comes with chain.) Put chain through closed loop, then weight eye, next attach chain to open hook, fixture if it comes with chain.) Put chain through closed loop, then weight eye, next attach chain to open hook, then close hook.

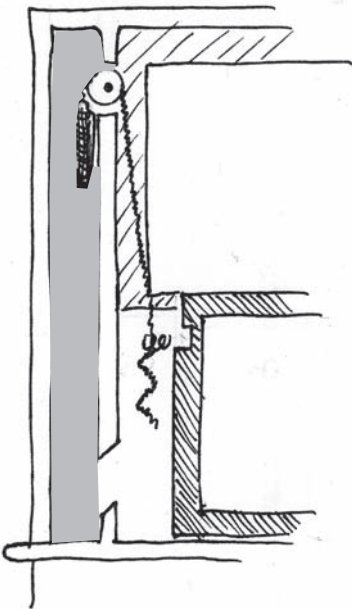
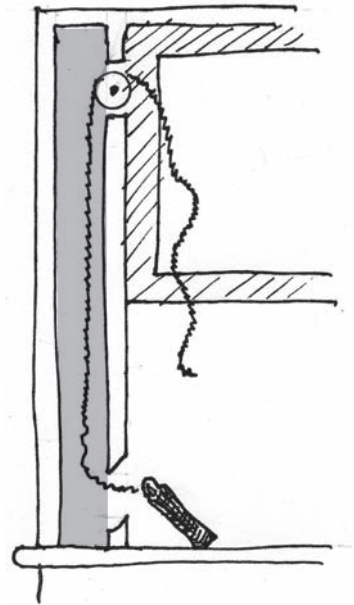
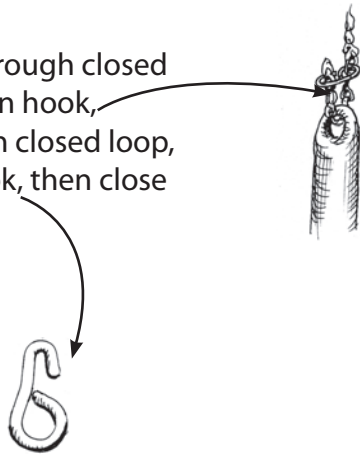

7 Place bottom sash on window stool. Pull chain until weight contacts pulley. Let pulley down a couple of inches. Push nail through chain at pulley to hold in place. Cut off chain just below round hole in sash edge. Turn chain halfway on spring-like fixture that comes with chain.

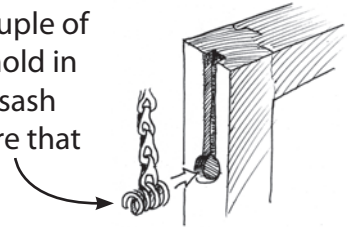

Push "spring" into round hole. Put a 1" screw through chain above spring hole. Pull nails from chain on both sides.

8 Push sash up and close weight compartment.

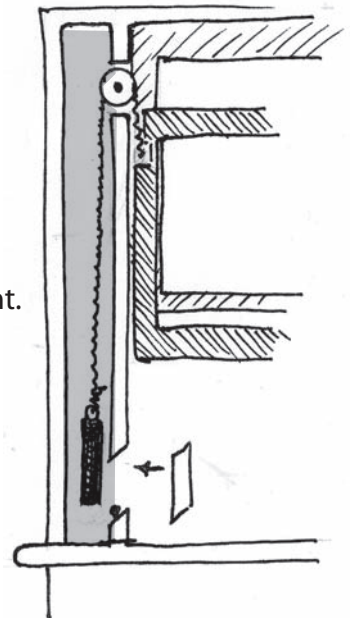

(See page 74 for lead safe restoration techniques).

If properly maintained, old-growth wood windows (particularly cedar) can last 200 years. They are environmentally benign and, unlike vinyl windows, contain no toxic materials. They can be made energy efficient if they are well glazed and weather-stripped. Restoring them creates well-paid, skilled, local jobs and can be done competitively. They can be easily repaired on site.

If the top sash is fixed in place, only the bottom sash needs to be restored. The following process makes the sash virtually lead-free and minimizes future maintenance.

1. Remove the inside stop and discard. Wet scrape paint from inside face of parting bead and area of jamb where bottom sash will rub.
2. Clamp sash to bench top (see p. 75). Unless glass is in good condition, and very well glazed, remove glass for reinstallation or replacement. The infrared heat gun (p. 74) will soften glazing putty, making it very easy to remove.
3. Where paint is not well-adhered, mist surface and remove paint to bare wood using a carbon scraper. Finish with orbital sander. Where paint is thin but well adhered, it can be easily removed with a HEPA assisted orbital sander. Where paint is thick and well adhered the planer works quickest. The goal is to remove most of the paint, removing as little wood as possible. Make the final pass with 100 or 150 grit paper. Use the infrared heat gun for stringent historic restoration (for example removing paint from detailed molding without scraping away wood from profile detail).
4. Glue-up or epoxy sash as necessary. Prime with highest quality primer and a compatible topcoat. For a paint job that will probably last more than 20 years but is expensive up-front, look into Allback paint, for example. 
5. Set glass into a bed of caulk that will remain flexible like an elastomeric caulk. Install glazing points, glaze, let dry, then paint glazing.

# Stripping of Wood Windows

An orbital sander with coarse paper can quickly remove thin paint, then sand to a smooth finish using fine paper.

When disturbing paint that may contain lead, always connect power tools to a HEPA vac to gather and contain most of the dust.

The infrared heat gun softens paint and glazing putty without burning wood. It creates a minimum of fumes, but user must still wear a respirator with carbon filters to be protected from lead paint fumes.

The planer removes paint from flat surfaces in a couple of strokes. The depth of cut can be easily adjusted.

Even when using a HEPA vac, always do this work in containment and wear at least an N 100, R100, or P100 respirator.

At the end of the operation, clean up area with a HEPA vac. then wet mop.

The HEPA vac, sander, and planer shown are made by Festo Co.

## Bench Top for Sash Gluing and Epoxy

- Make 3/4" plywood bench tops for each of several sashes being worked on at the same time. This will allow glued and/or epoxied sashes to remain clamped in place until glue/epoxy cures. Make bench top slightly larger than sash and cut off two corners to provide access to 2 corners of sash from top and bottom.
- Clamp sash to bench top, being sure one corner is tight in 45° corner. Then measure height and width to set correct dimensions before clamping in place. (Measuring diagonally corner to corner will confirm squariness.)

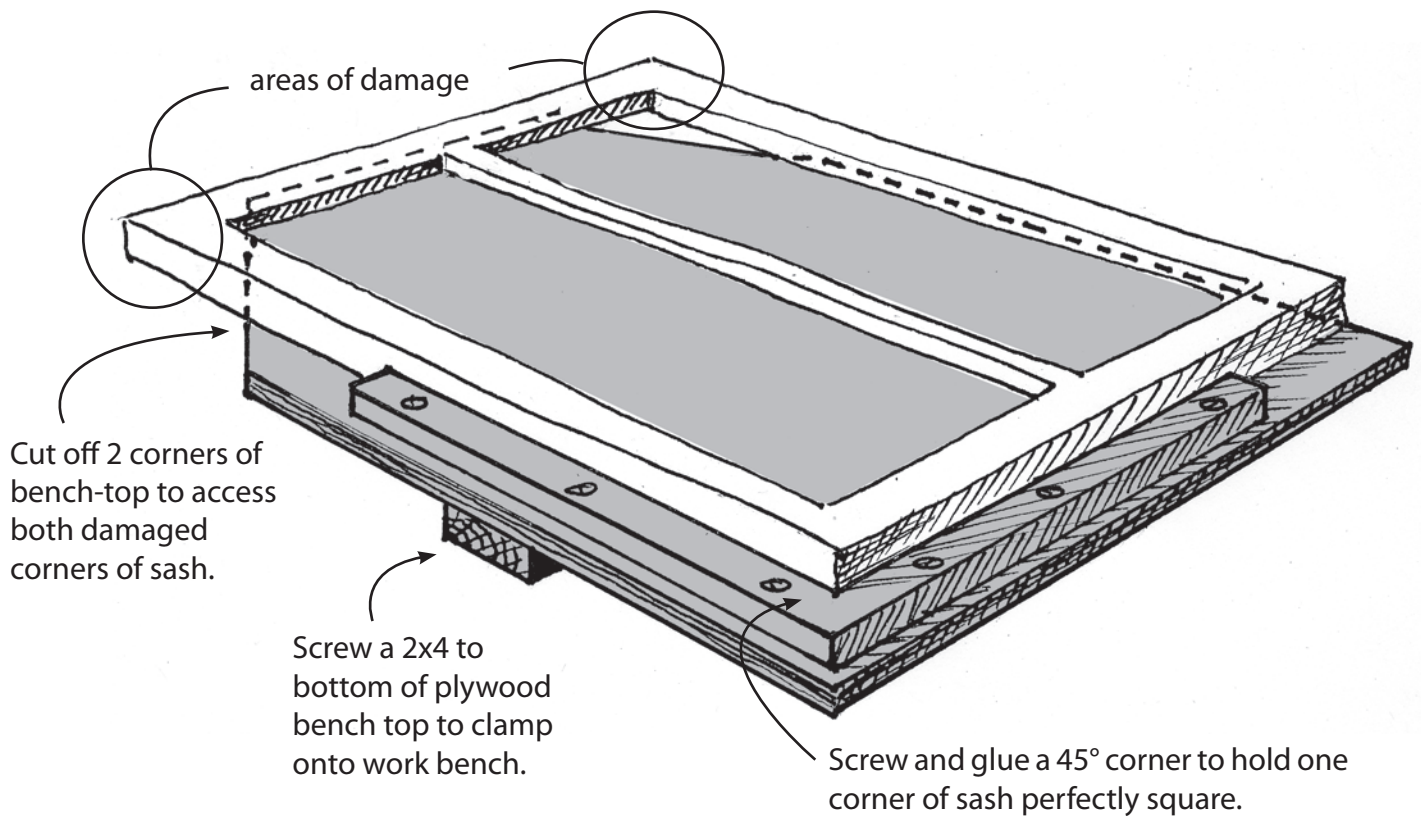

# Epoxy, Repair, and Restoration of Wood Windows

An old growth window sash is built like fine furniture. Its corners are mortise and tendon joints that are pinned with wood dowels that expand and contract. If the sash is well maintained and kept sealed, it will last hundreds of years. If they are not sealed they will absorb water and eventually rot. The end grain (designed to draw water to the tree's leaves) absorbs water easily and is particularly subject to rot.

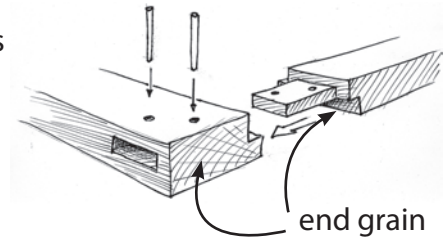

! Always wear high quality disposable gloves when working with epoxy.

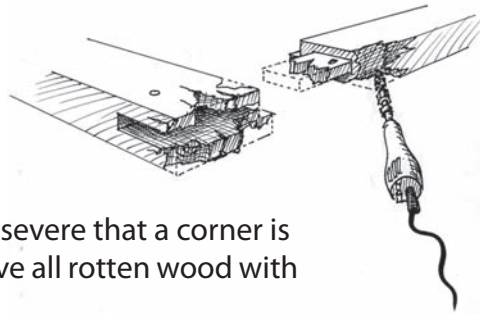

1 When the rot is so severe that a corner is coming apart, remove all rotten wood with a die grinder.

2 Soak edges of areas to be epoxied with primer mix.

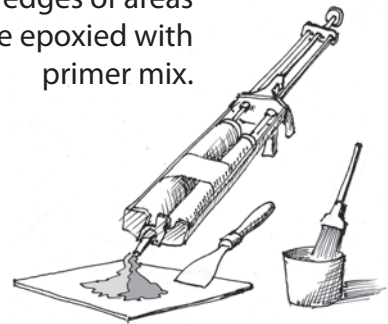

3 Mix the two part epoxy on a piece of plexiglass.

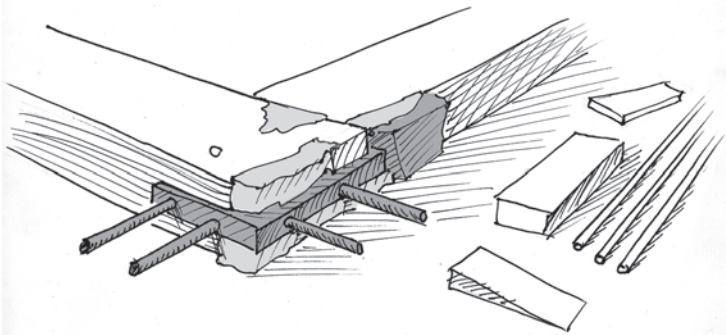

4 Clamp sash to plywood bench top (see p.75) and prepare scraps of wood that roughly fit gaps where wood has rotted away.

5 Butter all surfaces with epoxy, assemble sash, then push pre-cut scraps of wood into all gaps. This will force the epoxy into gaps and substantially cut down on the amount of epoxy needed.

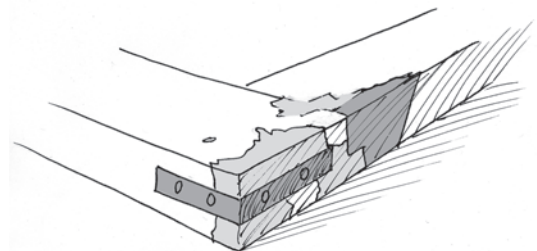

6 Push small scraps of wood into remaining voids. Let epoxy sit slightly above the surface.

7 Once the epoxy has set, cut off scraps of wood and sand down corners flush with sash. Drill holes in both directions and push in dowels covered with glue. Cut flush with sash face.

8 Perform final sanding on corner. Fill any remaining gaps as necessary.

# Floor Restoration

If possible save tongue and groove floors.

- Do not install wall-to-wall carpet because it can absorb moisture and become moldy (even without a flood). Use area rugs that you can remove before a flood, and take out and hang in the sun if they get wet.

## Tongue and groove on plank sub floor

This is a quality floor, but if water becomes trapped between the layers it may warp the tongue and groove floor beyond saving. At least try to save the sub-floor.

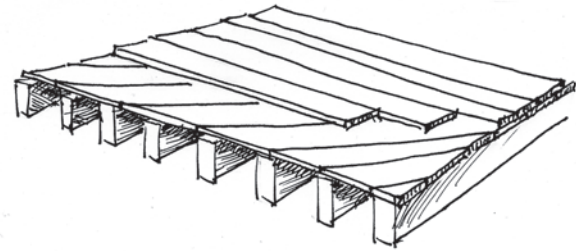

## Tongue and groove directly on joists

A tongue and groove floor exposed top and bottom to circulating air dries out quickly and can usually be saved.

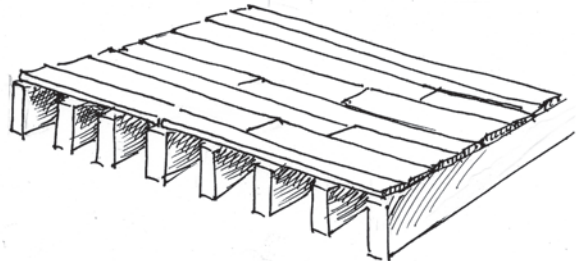

## Wall-to-wall carpet on pressboard

Always dispose of carpet that was wet. Pressboard that was soaked is almost always ruined. Replace with a tongue and groove floor. Use exterior grade sheathing or Plytanium Plywood Sheathing or equivalent if installing a sub floor.

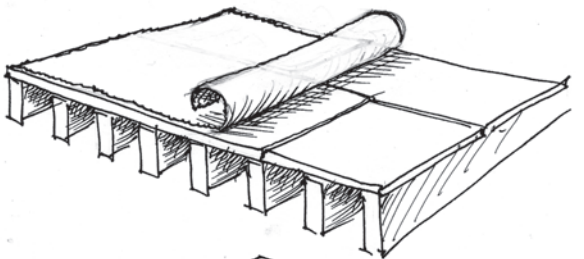

## Sheet flooring or resilient tiles over pressboard covered tongue and groove

After discarding wall-to-wall carpet and pressboard, try to save the tongue and groove floor. Large damaged areas can be repaired or replaced.

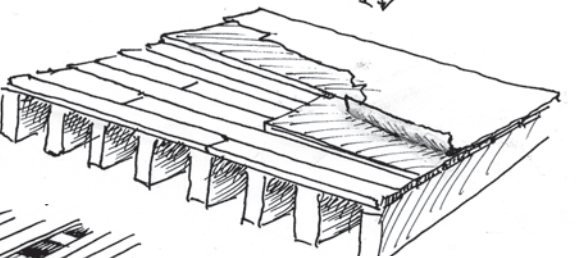

For minor warping, cut a saw kerf through the center of a board. This may create enough space to screw the board down.

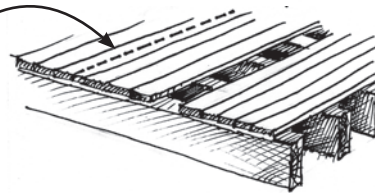

Where there is major warping, remove one board. Screw dry boards down. Use finish head screws if available.

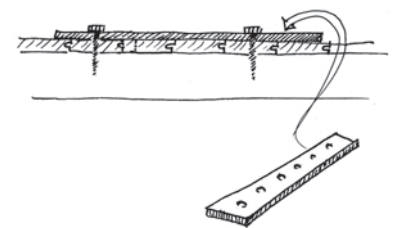
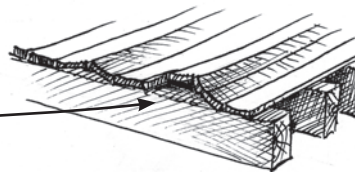

Screw metal plate or hardwood board across floor boards to hold them flat while you screw them in place. Pre-drill holes through floor boards so screw threads engage pilot hole in joist but not floor boards. Remove plate after a few days.

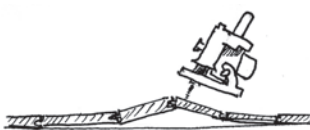

Once all other boards are dry and screwed down, rip removed board to about 1/4" smaller than the opening and fit in place.

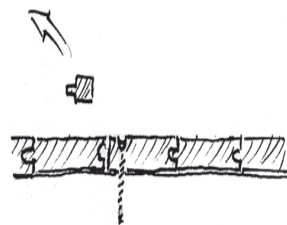



## Mechanical Systems

---

- Ventilation
- Air conditioning
- Heating
- Electrical
- Plumbing
- Appliances

When major flooding occurs in a house, the heating, ventilation and air conditioning system and other major systems and appliances can become disabled, damaged, or contaminated and will need to be restored. Mechanical systems may need to be installed in as many as three phases:

1 Systems necessary during safe and effective renovation. A plan for this is outlined in Chapter 5.

2 Installing interim systems may be necessary due to limited funds. These systems will be designed to allow a family to live in a healthy, safe, and relatively comfortable house before final systems are installed. This chapter will emphasize this phase.

3 Ultimately, occupants may choose to upgrade both systems and appliances as their budget permits. In the future, the authors would like to make this chapter more complete regarding appropriate heating, ventilation and air conditioning systems appropriate for use in areas at high risk for flooding. We would appreciate any comments about this.

### Principles:

Pre-WW II houses were designed to function with no air-conditioning and a minimum of space heating. Although they were frequently uncomfortable by today's standards, they were designed to minimize warm or cold extremes. This was achieved through the use of surrounding vegetation, opening and closing louvered shutters, porch overhangs, convection current venting, door transoms, and wearing warm clothes in chilly weather. When restoring older houses, before assuming centralized heating and cooling systems are necessary, consider restoring original systems. It is economically beneficial and ecologically sound.

# Heating, Cooling, and Air-Conditioning

Homes can be designed to minimize the need for central heating and air-conditioning. Initially this will be achieved by using passive systems, fan-driven ventilation, and small space heaters. As funds become available, window air-conditioners could be installed, or if funds are available, wall mounted mini split units are a good option. These units can function as air-conditioners or air-conditioners and heaters. Mini splits are easy to install, do not require duct work, and are efficient to operate. They can be installed completely above the flood line, up to 3 feet below the ceiling.

## Winter

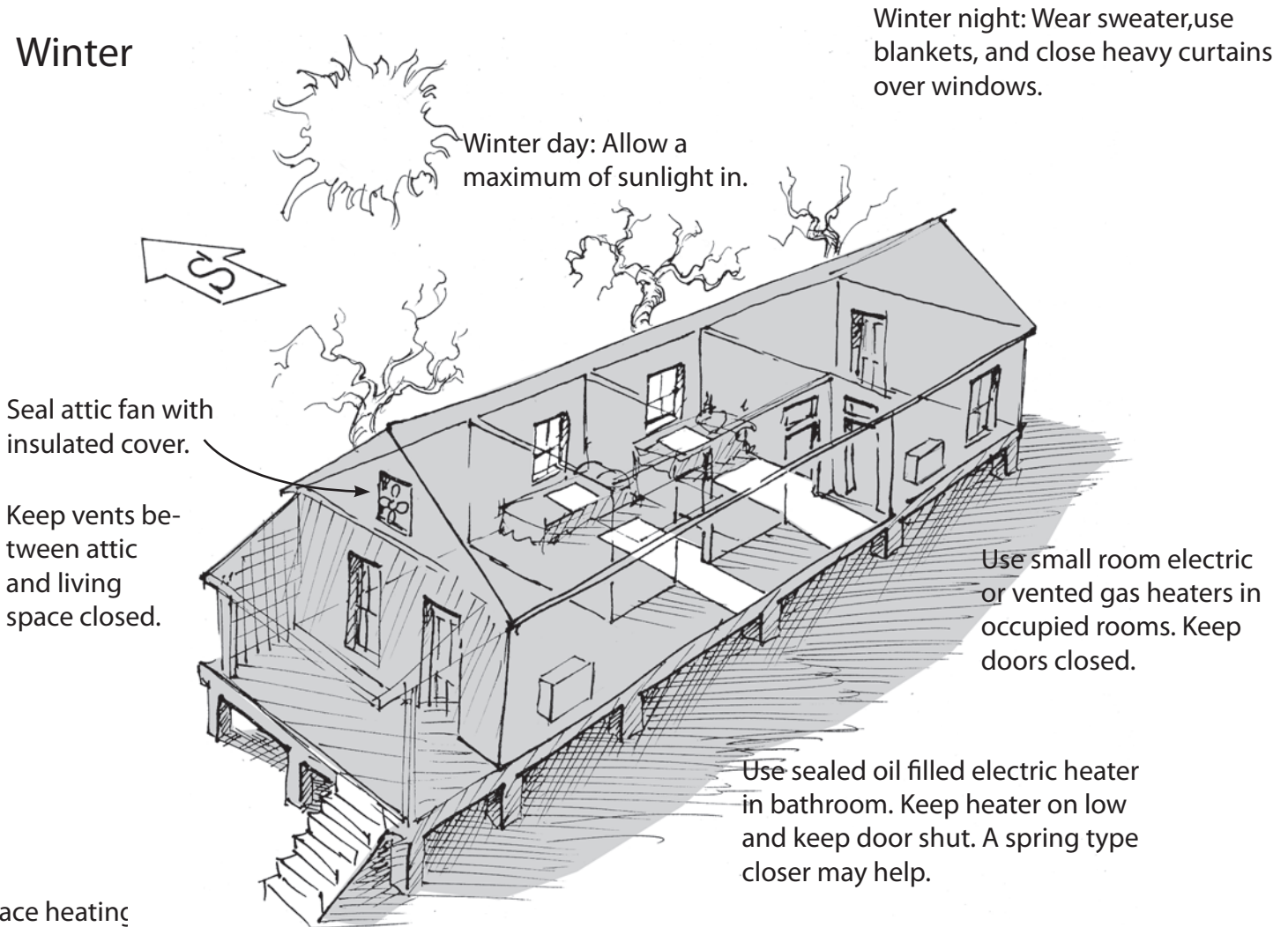

### Space heating

Electric heat is expensive, but if it is used in a focused way to heat a closed room or direct heat toward an occupant, it can be practical.

Gas space heaters are more cost effective than electric heaters. Gas or kerosene space heaters should never be used indoors unless they are vented directly to the outdoors. Similarly, a gas cook stove should never be used for heat and should always be vented to the outside. Stove hoods that re-circulate air rather than vent it outside do not protect occupants from carbon monoxide and do not remove steam from the air.

If a kitchen area is large enough, it can be turned into a family room. If both kitchen and a bathroom are heated, people can be kept warm in bedrooms with blankets.

## Summer

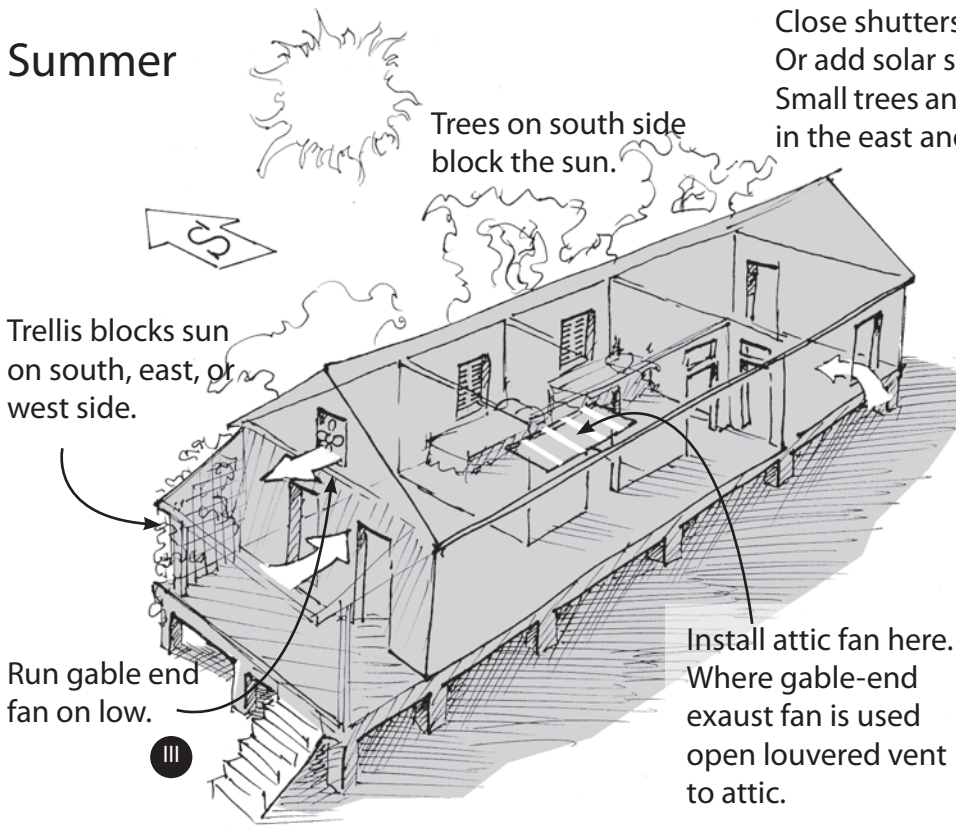

Close shutters on south, west, and east sides. Or add solar screens, solar film, or awnings. Small trees and large shrubs or trellises can be used in the east and west.

## Summer day

Ventilation can reduce the need for air-conditioning. Fan driven ventilation in combination with sun control can greatly increase comfort levels.

A ventilation system can range from a large window fan to a gable-end whole house fan. In either case, the fan would exhaust out from one opening other than a bedroom window. All other windows in the house, except for bedroom windows across from beds, would be kept closed at night so that cooler air is drawn across the bed. Partially closing this window will increase the velocity of air drawn from the outside.

It is important the bathroom has a fan vented to the outside to remove moisture. Clothes dryers must also be vented to the outside. Again, always vent gas stoves to the outside.

## Summer night

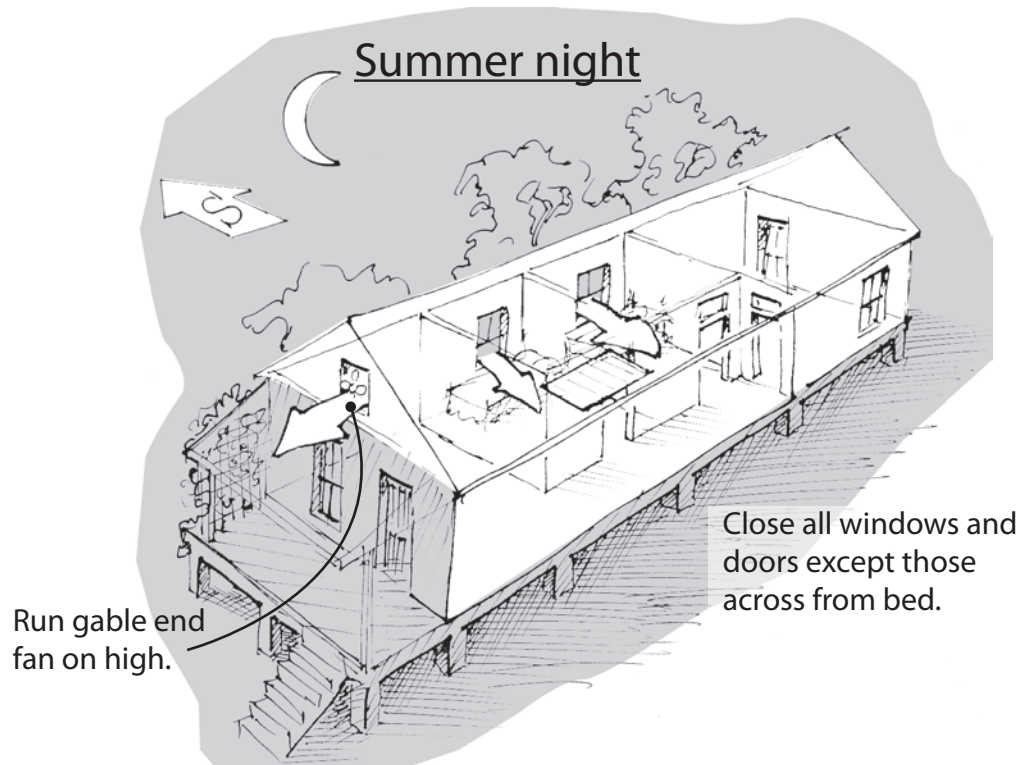



## Hurricane Resistant Designs

There are several measures that can be taken to make a home resistant to hurricanes, including adhering the roof decking to rafters, securing soffits, reinforcing attachment of columns to porch overhang, reinforcing attachment of chimneys and other structures, and bracing gable ends.

The Federal Alliance for Safe Homes (FLASH) and the Institute for Business and Home Safety (IBHS) have developed recommendations for making homes resistant to flooding and high winds. For more information, visit:  
[www.flash.org](http://www.flash.org) (FLASH) and  
[www.disastersafety.org](http://www.disastersafety.org) (IBHS)

This chapter discusses a new proposed measure for securing a house to resist strong winds or waves without the need to gain access to every single joint between plates, studs, and joists.

# Ground Anchor Hurricane Resistant Tie-Down

NOTE: This design is only a proposal. It needs engineer's review and specifications before being installed as a prototype.

It's designed for existing buildings where it is difficult to access all of the structural joints to install hurricane ties. It may be advisable to install diagonal bracing on the end walls to prevent the building framing from being distorted by wind. This could be achieved by installing diagonal cables on turnbuckles, inside the front and rear wall cavities. If the wall is open, a kerf-cut brace would work (see below).

If the building's attachment to the ground is not secure, hurricane ties are useless. This system would help solve that problem. But replacing brick piers with concrete piers attached to a slab with re-bar would further strengthen the system (see house lifting foundation design).

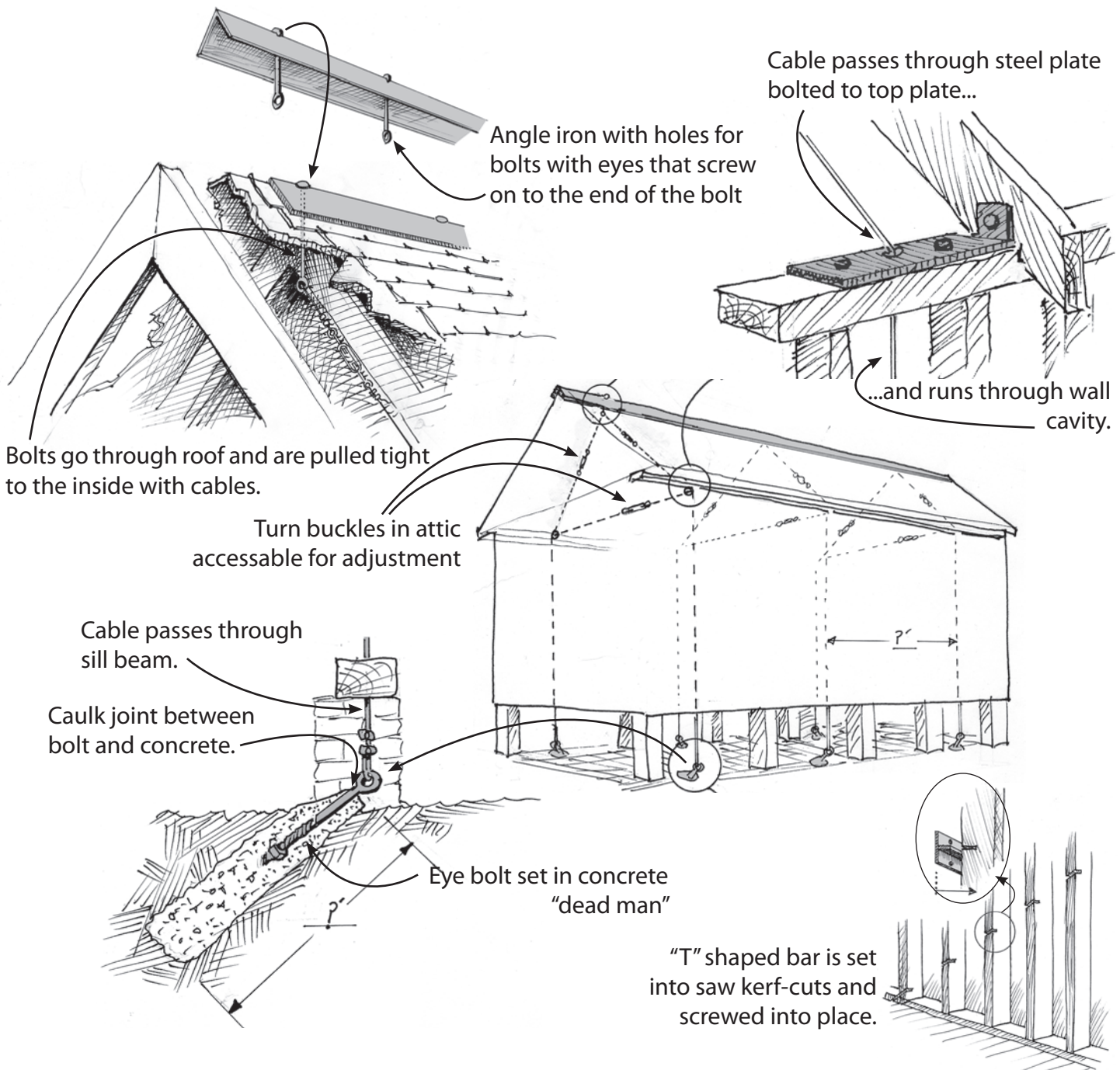

# Storm Shutters

Reasons to install and maintain louvered shutters:

- They keep the sun out during the day and still allow cross ventilation.
- They can be used to secure the house from breaks-ins when the house is vacant.
- Combined with a bolt and batten system, they can be used as hurricane shutters.
- They are part of hurricane regions' historic fabric.

## Converting Window Shutters into Storm Shutters

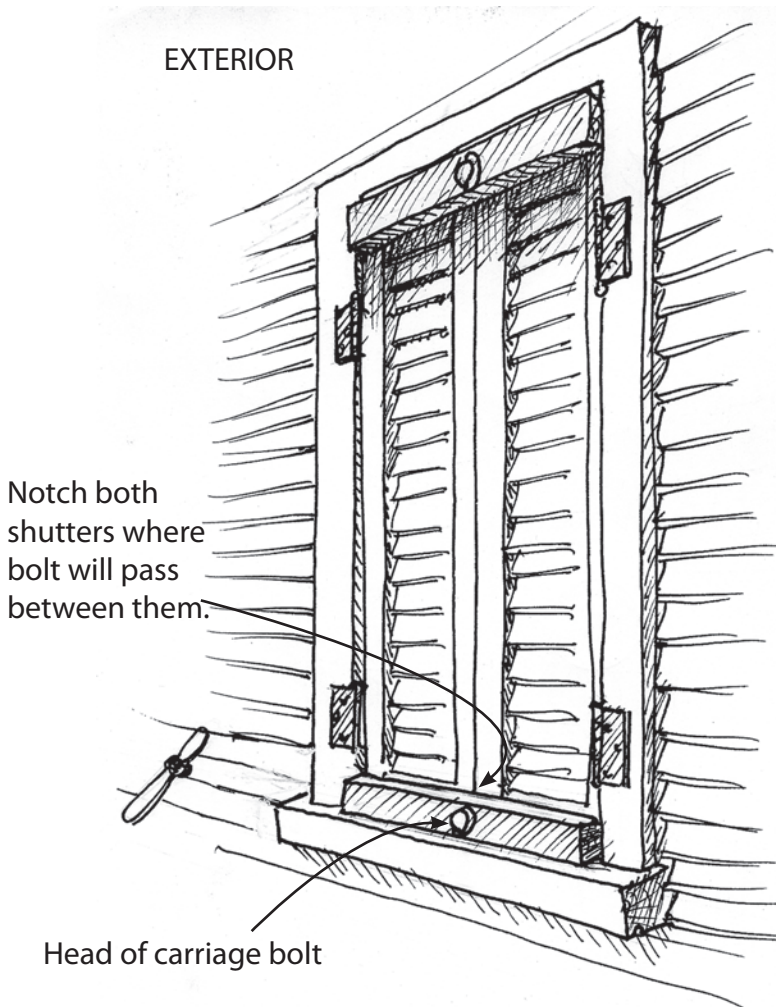

Plywood board and batton system could also be used. See p. 38

Drill hole through top-sash top-rail, and bottom-sash, bottom-rail for carriage bolt. Holes can be filled with removable plug. Once nut is snug against fender washer, drive long wedges between casing and battens to tighten up bolt.

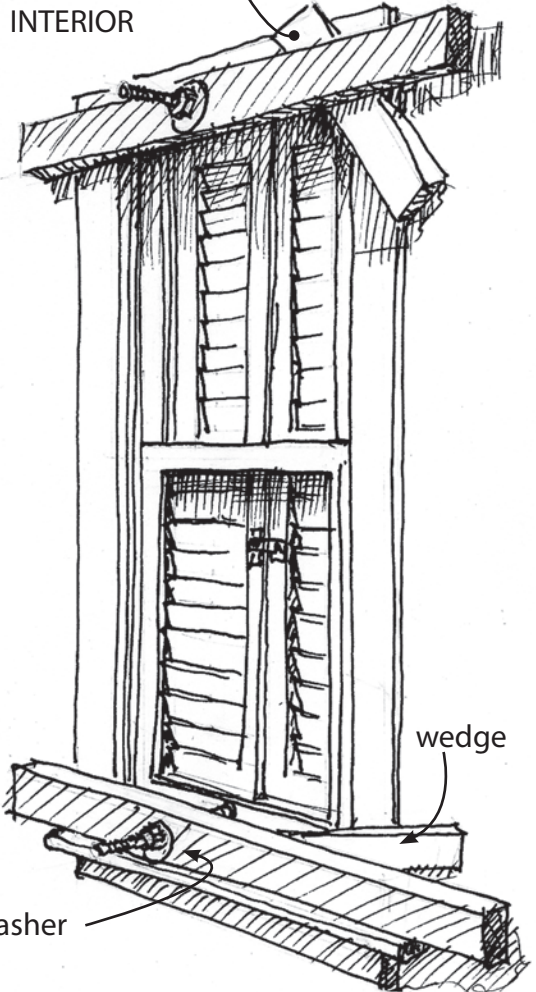



# Chapter 11

---

## House Lifting Strategy

design by Scott McDonald

Soil conditions must be checked by a soil engineer or other competent person before choosing this system.

### 1. Replace brick piers to:

- raise the house above flood line
- replace sill beam if necessary
- prevent uneven settling
- prevent house from being pushed, floated, or blown off foundation

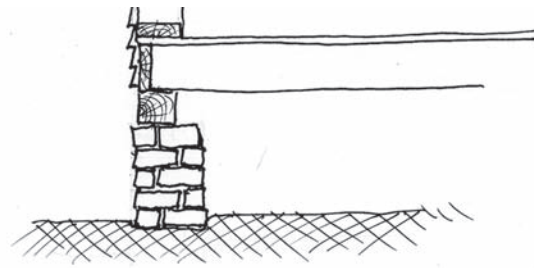

### 2. Setting lift beam

Save chimney by building support for masonry from first floor up. Masonry from first floor to grade will be removed then replaced.

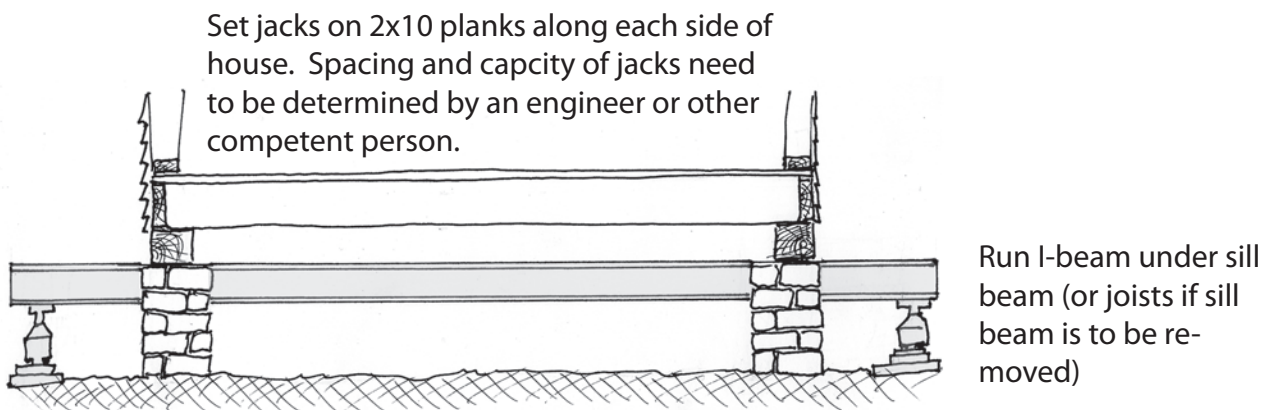

### 3. Setting cribbing

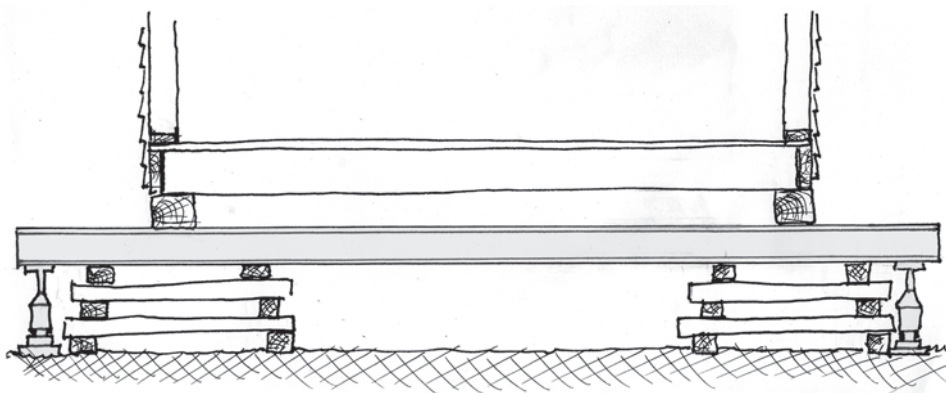

As building is lifted, add cribbing beams as soon as a new row will fit. When building is supported by cribbing beams, remove brick piers.

#### 4. Dig footer trench and set rebar

Dig trough for footing around the building's perimeter and under existing or future chimney. Dig trough 2 ft wide and 1 ft deep at spot where ground is highest. Center the footing on the center of sill beam. If grade drops (ground slopes) step footing so it remains at least 1 ft below grade. Build wood retaining forms where footing rises above grade.

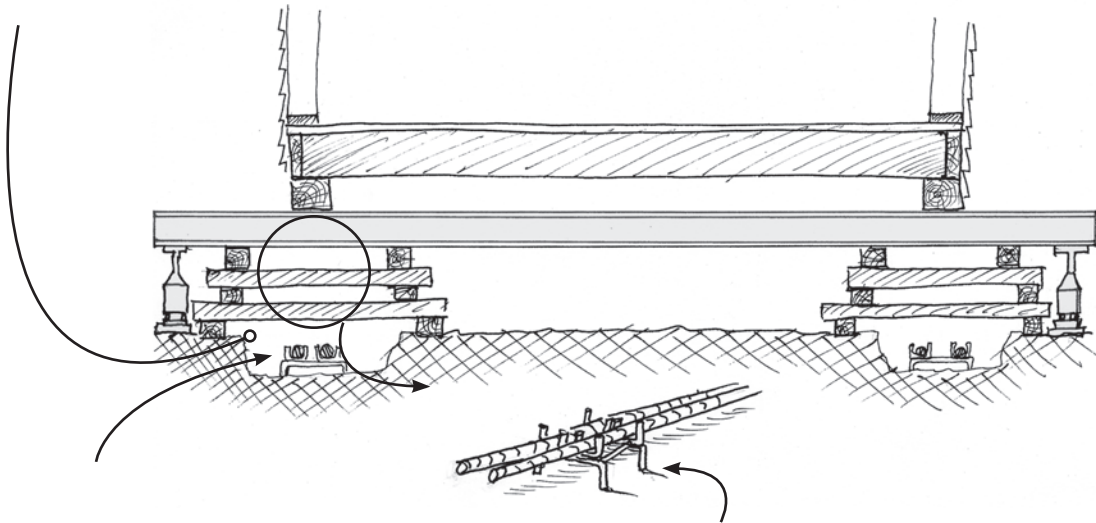

Set two rows of rebar (reinforcement bar) in center of trough on rebar chairs.

rebar chairs hold rebar in center of footing

Once jack has reached its height-limit, let building down on cribbing. Then build cribbing pile under beam where jack will go, leaving room for fully compressed jack.

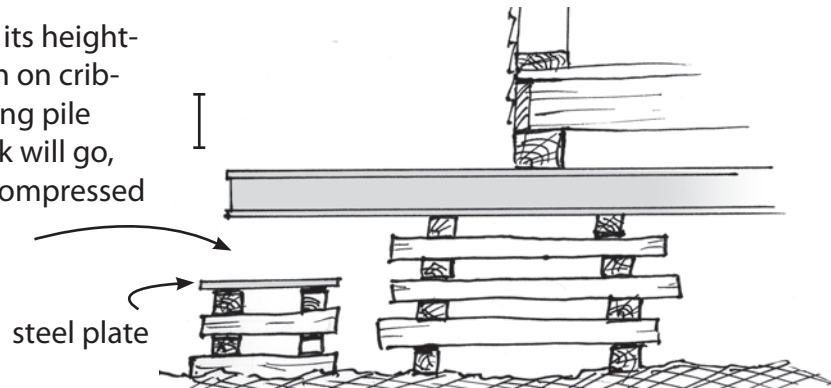

#### 5. Extending vertical rebar

Once desired height is achieved, tie "L" shaped vertical rebar to horizontal rebar. Tie all-thread to rebar so it extends to approx. 1" below top of sill beam. Grease all-thread that will extend above pier to protect it from concrete.

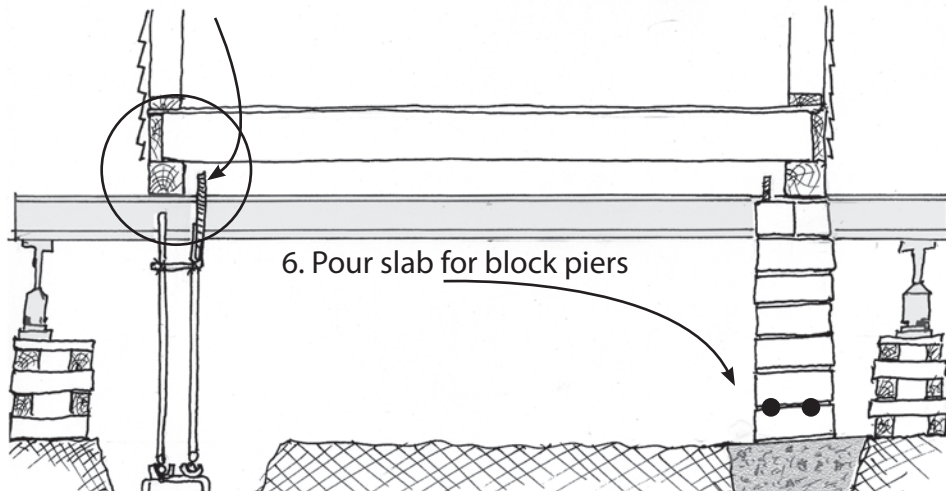

### 7. Build pier

Set ivany block, which can be purchased at local masonry outlet, around rebar. Outside face of block to be flush with outside face of sill beam.

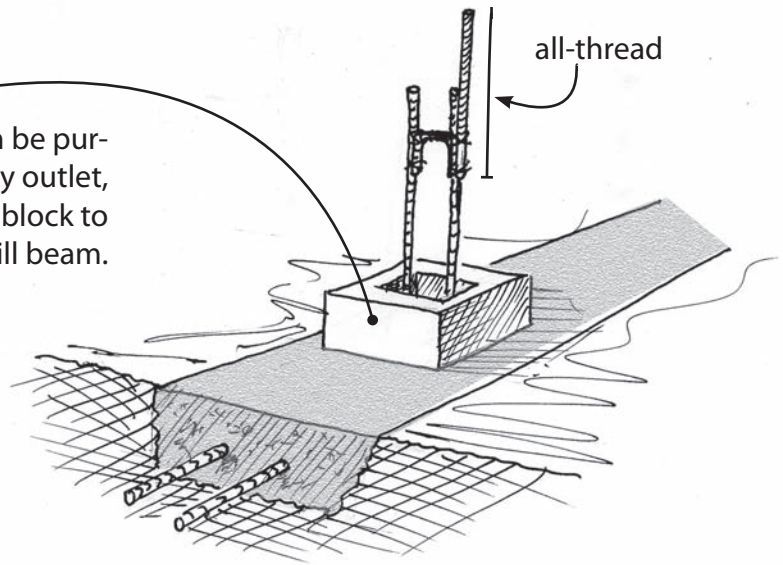

### 8. Fill void with concrete

Set ivany block over vertical rebar. Fill void with concrete. Slide two C-shaped blocks for last row, set all-thread, install termite shield (see drawing 9), tie top C-blocks together, then pour final void.

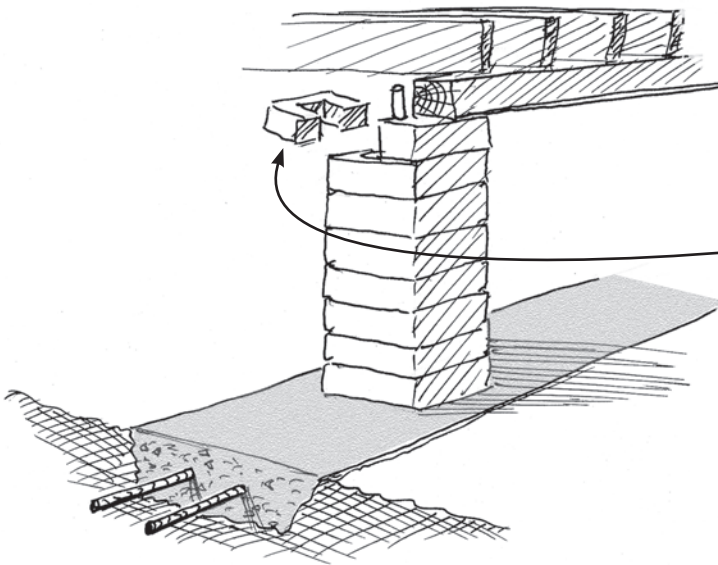

## Overview of piers

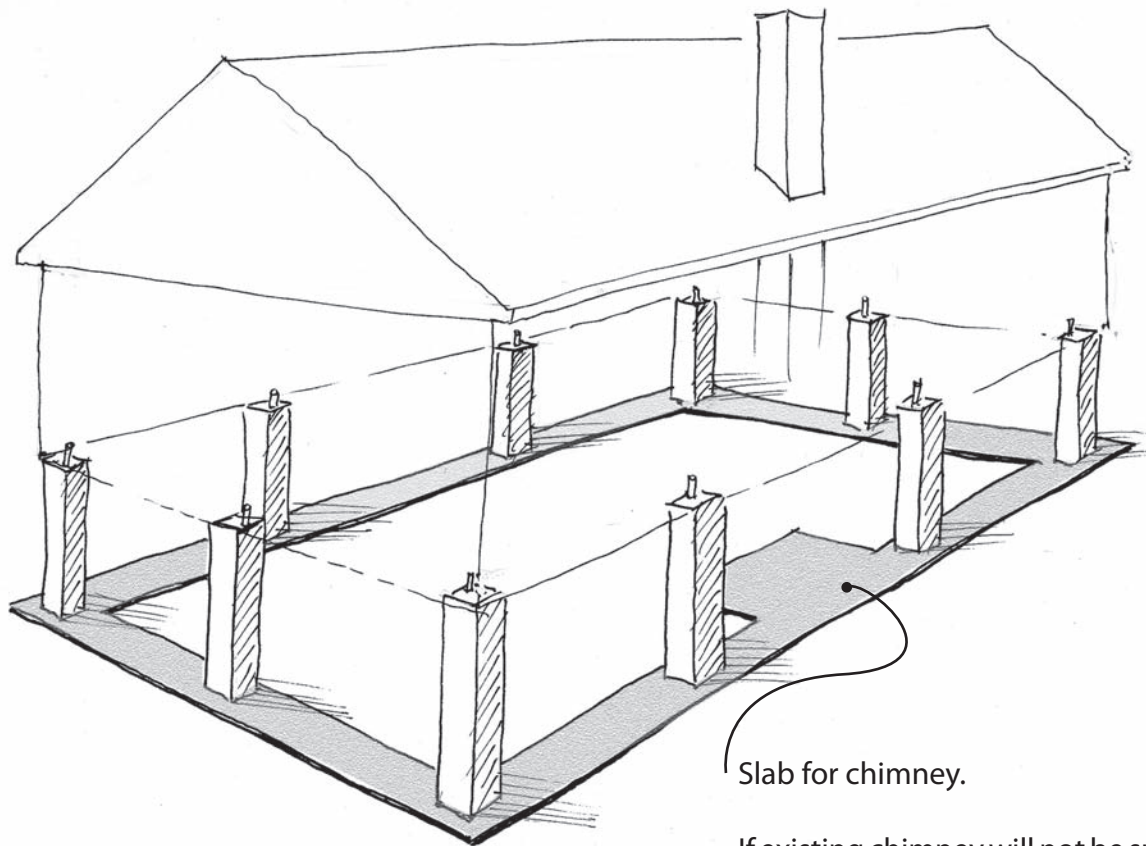

Slab for chimney.

If existing chimney will not be supported by slab it may need to be removed.

### 9. Bolt pier to sill beam

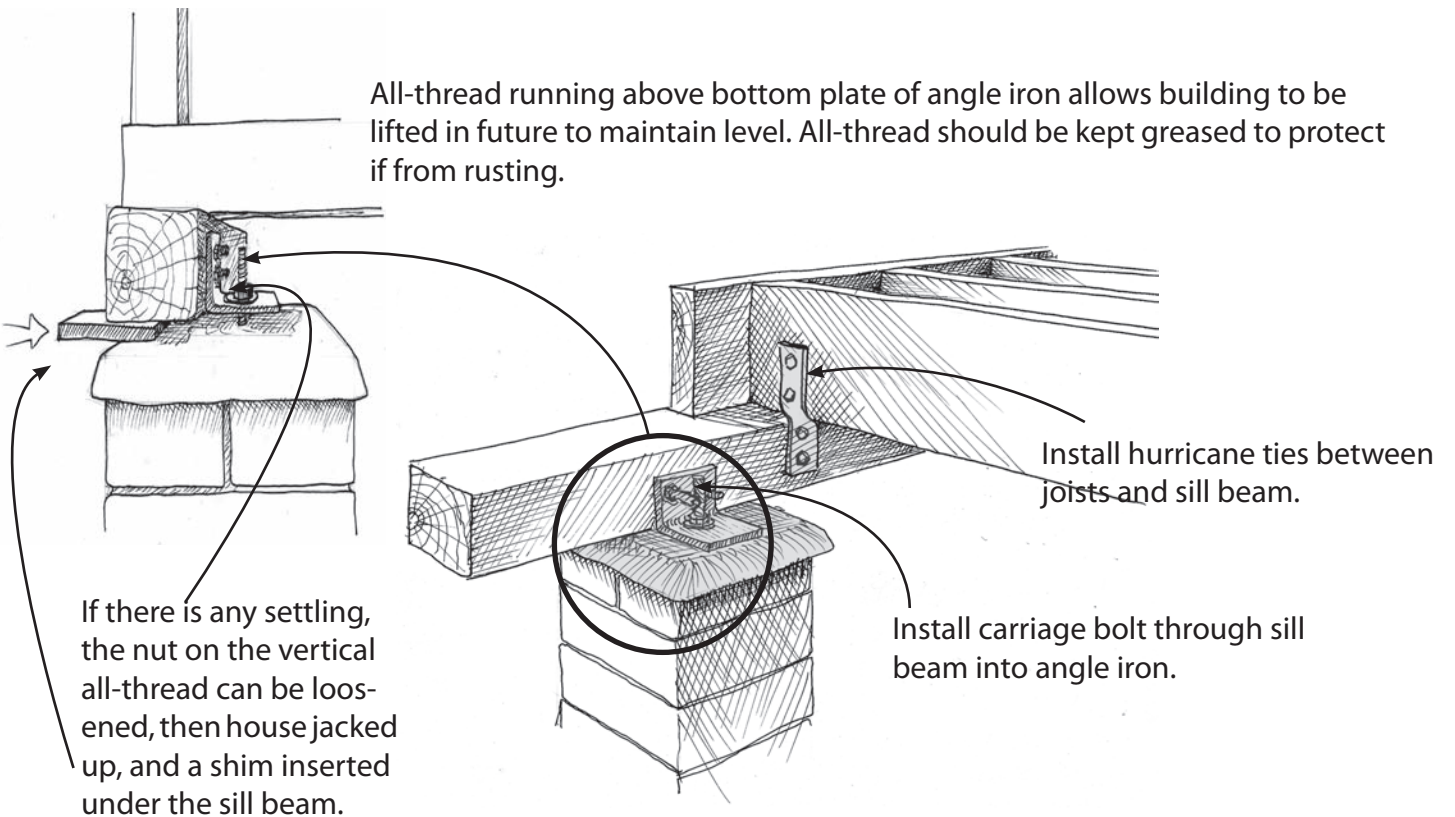



---

## Case Study: Critical Issues and Unresolved Questions for Restoring Damaged New Orleans and Gulf Coast Homes

The authors would very much appreciate any feedback (including comments, disagreements, new ideas, drawings, etc.) addressing the proposals and questions in this Appendix—or addressing any of the manual’s content. Please email your feedback to [rscott@afhh.org](mailto:rscott@afhh.org) or mail hard copy to: Alliance for Healthy Homes, 50 F. St.,NW, Suite 300, Washington, DC 20001.

Lessons about effective ways to rebuild following large-scale water intrusion into homes can be learned from the aftermath of Hurricanes Katrina and Rita that devastated New Orleans and the Gulf Coast in 2005. This disaster prompted the writing of earlier editions of this manual. Most examples and illustrations in this manual relate to water intrusion as a result of a hurricane but they have wider applicability to water intrusion due to other causes. It is important to note that when flooding occurs from a river, there is the additional concern about sustained water currents washing out soil under buildings that is not addressed in this manual.

In the early editions of this manual, the authors identified several technical areas in urgent need of clarification. We believe these questions may be relevant to communities facing other large scale disasters involving water intrusion into homes and other buildings. Thus, we have included the following discussion of unanswered questions and some possible solutions as a “case study.” Where possible, fully-developed solutions should include installation protocols, product names and sources, and approximate cost.

---

We’re assuming that there will be future hurricanes more powerful than Katrina and New Orleans, the Mississippi Coast and communities across the country will flood again. We also assume that response from the Federal and local government will continue to be inefficient, at best, and low-income communities will continue to fight for but not receive their fair share of funds.

We are interested in protocols to enable low-income people to move as quickly as possible into a tolerably comfortable home that is both healthy and safe. It’s understood that substantial additional work may need to be done to fully restore the home in the future. It’s hoped none of the work done at the initial stage will need to be redone.

The emphasis on saving historic fabric is as much for the intrinsically efficient systems design, cost effectiveness, and health benefits as for its historic value. For example, plaster, unlike drywall, discourages mold and roach infestation. A polyvinyl chloride replacement window contains environmentally toxic materials and will not pay for itself in energy savings before it wears out. A well whether-stripped, old-growth, wood window can be restored and maintained to last another 100 years. A combination of porch overhangs, louvered shutters, internal door transoms, and venting create relatively high comfort levels many months of the year.

Our goal is to provide as few choices as possible. If a solution is good for 80% of the target properties, those will be the properties we'll address. In the future, given technical and financial capacity, the unique problems of the remaining 20% properties can be addressed.

## The prototype house

- Pre 1930 shotgun, bungalow, or similar with platform or balloon framing
- One story, gable-end, 1,500 to 2,000 sq. ft. (attic same)
- On brick piers, 2 ft to 4 ft above grade
- Wood lap siding usually attached directly to studs
- Interior plaster on wood lath, to be saved if possible
- Water reached no more than four feet above the floor boards (unless house is to be lifted).

We understand there may be certification and licensing restrictions. If these become barriers to affordable access by low-income communities, strategies to overcoming these barriers need to be developed.

## Criteria for choosing a work protocol:

1. Favor labor-intensive work protocols - Minimize capital equipment and maximize local labor opportunities.
2. Protect worker, occupants, and environmental health - Use materials and systems that have the least health risk for producers, installers, occupants, and the environment. We especially want to ensure the healthfulness of the occupant's environment.
3. Make decisions based on life-cycle cost where economically viable - Minimize initial costs while taking into account life-cycle costs, including replacement projection, energy consumption, and ongoing maintenance costs.
4. Maximize energy-efficiency – Wherever possible, use passive systems that require minimal maintenance and up-front costs. Chose simple, inexpensive, and easily installed HVAC systems that emphasize ventilation and zone conditioning.
5. Preserve historic systems - Maintain the historic fabric and design of the house. Where practical, this includes restoring passive systems such as shutters and operating door transoms.
6. Incorporate flood resistance - Make the house as flood resistant as possible to minimizing the potential cost, damage, and recovery time caused by water intrusion.
7. Build-in hurricane resistance - Make the house as wind and wave resistant as affordable.

## Critical and Unresolved Questions

Although the following items are presented as recommendations, they are all subject to review and revision. They are simply based on what the authors have accumulated and learned in the production of this manual and their intent is to elicit criticism or support.

## Window Replacement Options

Where existing windows cannot be saved, what replacement window, that does not contain polyvinyl chloride, should be recommended?

Given homes that are occupied by people with extremely limited budgets who do not have the luxury of a fully conditioned insulated space 12 months a year, we've identified the following critical questions that still need to be answered.

## Heating, Ventilation and Air Conditioning

Generally this manual assumes that a combination of natural ventilation, fans, keeping out sun on hot days, space heaters (electric or vented gas), and zoned air conditioning, will render most Gulf homes "tolerable" without central heat, central air conditioning, or insulation.

### Ventilation

Except for extremely hot or humid days, a strong exhaust fan can keep occupants, tolerably comfortable. This works best where windows are closed except for the window closest to the occupants, for example the window next to a bed at night. Ideally the window fan is installed in a hall window. Even better, a gable-end fan controlled from the living space might be available. A window fan should be brought in during cold weather and would be installed so that the window could be closed while air-conditioning is run. The gable-end fan would have exterior louvers that would shut when the fan is off, to keep out rain, retain air-conditioned air, and prevent heat loss. An insulated lid could be installed in the winter to further prevent heat loss.

Does the house need to be sealed well? What is a cost effective way to install a balanced ventilation system whose source is conditioned by a dehumidifier?

Some products to consider are:

- Ambiance AS09CR, 9,000 btu, cool only, \$600
- Sanyo 24KMS12, Dual-Zone, 24,000 btu, cool only, \$2,300
- Sanyo 09KHS51, AC Heat Pump, 9,000 btu, \$975
- Mr. Slim Model # MSM18TW, Capacity - BTU/h (cooling), 17,000, Seasonal Energy Efficiency Rating 10.2 has an aspect that minimizes air conditioning while increasing dehumidification. One model should condition 3 rooms.

Sizing the fan

Using the formula sq. ft. of floor space x ceiling height x .05 = required CFM (Cubic Feet of air per Minute):  
1,500 sq. ft. x 9' x .05 = 8,000 CFM. So a 1,500 sq. ft. house would require an 8,000 CFM fan

A TPI shutter mounted, 2 speed, 120 V, 1/4 HP exhaust fan meets these requirements. It costs about \$400 plus labor.

Functional wood shutters, which can also serve as storm shutters, and operative door transoms, would further increase the effectiveness of this system. On mild days shutters and transoms would work without a fan.

Would it be possible to run a gable-end fan off a battery for a few days in an emergency? What kind of battery would work?

## Zone Heat

What is a cost-effective, energy efficient design for a heating system that can zone heat?

## Spot heating

Small, vented gas space-heaters are also very effective and cost less to run than electric. Under no circumstances should any combustion unit be used without ventilation. (This includes gas cooking stoves that should always have an outside-vented hood. Using a counter mounted stove and above-counter oven can avoid their destruction during a flood.)

Although electric heat is expensive, small ceramic heaters in closed occupied rooms are very effective on all but the coldest days. An oil-filled electric heater in the bathroom, kept at a low temperature, is effective for comfort and allows people to tolerate lower temperatures in the rest of the house. The bathroom door would need to be kept closed. A spring-closer is helpful. An effective exhaust fan is critical. It should continue to run for a few minutes after the bathroom is vacant. Better still, a fan that switches from high to very low speed to maintain constant controlled ventilation.

## Moisture/Humidity

Can a dehumidifier be used without air conditioning if you use ceiling fans to replace air conditioning on marginal days? Is this combination much cheaper than air conditioning in achieving similar comfort levels?

## Wall Insulation

Necessary characteristics of insulation material are:

- Capacity to dry out quickly and completely after being soaked
- High resistance to mold growth and insect infestation
- Highly permeability
- Will not settle over time
- Minimize air infiltration
- Safe for workers to apply
- Safe for occupants and the environment (emits no VOC's)
- Made from a renewable resource (meet LEED criteria)
- Inexpensive per R factor
- Easy to install in irregular wall cavities
- Minimum of capital equipment needed to install
- Minimum of skill needed to install

## Roof insulation

Roof insulation should meet the same criteria as wall insulation except there may be a benefit in adding a reflective surface and it would not be exposed to flooding, so moisture resistance would not need to be so effective.

## Hurricane resistance

There is a need to develop a specification for installing hurricane ties in older houses, particularly houses with plaster walls intact, that does not require gaining access to every single joint between plates, studs, and joists. Chapter 10 of this manual contains one suggested solution, but it had not been fully evaluated by an engineer. This review still needs to be done. What are some other possible solutions to this problem?

## Asbestos

Where is it most frequently found? Can it be assumed to be asbestos or does a sample need to be sent in? In the case of pipe insulation, can it be enclosed (for example wrapped with 3M mesh), or is it critical that a certified asbestos crew does this work? If 9" x 9" tiles are assumed to be asbestos, what is the risk to removal in residential situations?

## Sewer Waste Pipes

Is there sufficient reason to install back flow valves on sewer waste pipes to justify the expense? What is the expense?

## Borate Solution

Possible Health Risks of Applying Borate Solution - What are the exposure risks to people applying borate solution to framing members using pressure sprays? What is appropriate worker protection?

## Working in Moldy Buildings

Is there an effective way to knock down toxic levels of mold before clean out and demolition begin to lower worker exposure? Current suggestions include:

- Running an ozone generator with the building vacant.
- Misting surfaces with "efficient microorganisms" (EM) - Common Ground Collective has used this with positive feedback from volunteers.
- Misting surfaces with a borate solution - Stephen Frantz in a Nov. 11, 2005 memo gave this technique a positive review.

## Consistency with Codes

The entire manual needs to be reviewed carefully for compliance with the International Residential Code for Existing Buildings.

(Note: Mention above of specific products does not imply an endorsement of these products by HUD or the Alliance for Healthy Homes.)



---

## Community Rebuilding: An Anchor Block Strategy

By Dennis Livingston

Often, an additional causality of disaster causing severe wind or flood damage is people's ability to believe their world can be rebuilt. Restoring one's home while still surrounded by damaged, abandoned houses can be very discouraging. To mobilize effectively to restore and rebuild, a community must have a clear and concrete vision of where it wants to go. One way to do this is to build a microcosm of that vision.

### Rejuvenate "Anchor Blocks"

An initial shortage of resources should not be used as an excuse to demolish or dismember large tracts of neighborhoods. As communities struggle for resources, they can strategically chose blocks to anchor their vision of rejuvenation. An ideal block would be:

- Close to a school, church or recreation center that can be used as a living area and training facility for work crews, a tool loan facility, a community center, and a celebrations hall.
- Made up of houses that are, for the most part, structurally sound. At the same time houses that can't be restored immediately due to lack of funds should be cleaned out, ventilated, and secured (including roof repair).
- Home to politically active citizens attached to a citywide organization.
- Occupied by homeowners or cooperative rental property owners.
- Be visible from a major roadway or commercial area. Good theater needs and deserves a good audience.

## Create small versions of the large vision

Set up an efficient production system. Do the same work at the same time for all the houses in the anchor block. This allows for appropriate tools to be shared and compatible work coordinated. We don't want garbage being dragged out by someone in a respirator next to someone planting flowers.

In general, the work sequence would be:

1. Remove damaged materials from houses as quickly as possible.
2. Clean and secure what can be saved.
3. Create a sense of identity and recognize the contributions of everyone involved in the restoration effort. Give a name and/or symbol for each block. Print it on banners at both ends of the block. Paint symbols of participating organizations, neighborhood institutions, local churches, and children's fantasies on streamers, flags and banners. Hang them from houses and bamboo poles up and down the street. If it looks like a party, it's a party.
4. Repair or replace the roofs then clean out, dry-out, stabilize, and make houses environmentally safe.
5. Repair the windows and doors then paint the exterior trim wonderful colors until there's enough money and labor to paint the rest of the house.
6. If vacant homes predominate, bring one house in the middle of the block to an safe and habitable level as a "demonstration house". Even if the home's occupants are not ready to move back in, someone can stay there and keep an eye on the street.
7. Plant trees and flowers along the blocks and install raised-bed vegetable gardens.
8. At achievement points in the process, have celebrations that include food, music and bright lights. Invite television cameras, tour buses, and church groups to join the celebration.

...Then onto the next block, in the middle of the next neighborhood needing to be saved. As resources permit, each of these anchor blocks will be a starting point for surrounding blocks.

## Build local capacity

Retain dollars spent in the neighborhood by building the capacity of small local contractors. This will create a supply of well-paying, rewarding jobs for community people. Create alliances with historic restoration agencies or organizations to reap the environmental, health, and economic benefits of restoring historic buildings. Train workers to deal with post-disaster restoration. And build a service core for these contractors where they will share administrative support, bulk purchasing, capital equipment, and facilities.

Coffee houses, laundromats, grocery stores, and day care centers are signs that a neighborhood is vital. At start up, these may consist of a coffee machine in someone's living room, a washing machine in an empty garage, local farmers showing up with produce, and a "healthy house" for baby-sitting.

The strategy is to create a microcosm of the future vision in each neighborhood, keep neighborhood residents in charge, ensure that local businesses are involved, tell the recovery story to the larger community via mass media and other forms of communication and celebrate achievements frequently.

## Tools, Supplies, & Resources

Several products (tools and materials) are mentioned by name in the manual. This appendix includes information about their prices and how to obtain many of these products. Mention of these products does not imply an endorsement of them by HUD or the Alliance; they are merely provided for the convenience of practitioners as examples of products that can be used for the activities described in the manual. In many cases alternative products may also suffice.

### Tools

#### Infrared heat gun and carbide scrapers

- Silent Paint Remover (minus 10% for demo unit) \$ 465
- Scraper Kit, 6 scrapers + 5 triangular blades \$ 250
- Vacuum assisted scraper \$ 24

Viking Sales Inc. 585-924-8070 / [www.silentpaintremover.com](http://www.silentpaintremover.com),

#### Carbide scrapers

- Hyde carbide scrapers
- 1" triple edged scraper 448XXX \$ 14.99
- 1" replacement blade 449XXX \$ 5.99
- 2.5" scraper 450XXX \$ 19.99
- 2.5" replacement blade 451XXX \$ 7.99

[www.toolcrib.amazon.com](http://www.toolcrib.amazon.com) / 1-800-635-5140

(Home Depot is another source)

#### Vacuum cleaner

- 103309 Sierra CM Backpack Vacuum w/basic tools \$ 449.00
- 101220 High filtration disc-2 pack \$ 9.70
- (change after using ten filters)
- 103083 Wheeled hard floor & carpet tool \$ 28.12
- 103523 "Flexi-clean 24" long crevice tool \$ 17.51
- 103227 10 pack filter bags \$ 20.00
- 103242 Beater bar power head \$ 300.00

(for use if you will be vacuuming high nap carpets)

These are list prices. Get several local distributors to bid against each other for a local retail price. Call 1-800-541-1456 for local distributors.

[www.innovativevac.com](http://www.innovativevac.com) /

#### Carpet cutter

- Gundlach #265 Jus-Push carpet cutter \$ 107
- 618-233-1781 for local distribution

#### Shutter mounted exhausted fan (fan & louvers can be mounted from inside)

- AGP-28299 sq. 6,900 - 5,000 CFM \$ 323
- AGP-28305 sq. 7,900 - 6,000 CFM \$ 405

C&H 800 558 9966 [www.chdist.com](http://www.chdist.com)

Fan (will vent two rooms at once)  
Tamarack Technologies 800-494-4185  
Fantech F Series fan

Cart, tool pouch, end cut pliers

- Big Wheel Cart- 4W504	\$ 240.75
+ rear castor- 4X835	\$ 19.62
- End cutter pliers- 3LY74	\$ 19.08
- Canvas 10-pocket nail & tool pouch- 3BB54	\$ 9.99

Grainger: [www.grainger.com](http://www.grainger.com) / 1-800-473-3473 (for CD-ROM catalog)

Positive air hood

- head cover	52392	\$ 64.25
- breathing tube	52393	\$ 21.25
- HEPA assembly	52394	\$ 262.25
- battery unit	52795	\$ 113.85
- extra filters	GUP-440	\$ 24.00 each

AramSCO: 856 848 5330

HEPA vacuum assisted sander and planer

RO125 sander	\$ 350
HL850 E planer	\$ 430
CT 22 E HEPA vacuum	\$ 425
CT mini vacuum	\$ 285
Compact cleaning set	\$ 62

Festo Tools [www.festoolusa.com](http://www.festoolusa.com) check website for lower package prices  
888 337 8600

Applicator for TermitePruf  
12 volt pump \$ 295  
(powered with a 12 volt car battery)  
Oldham Chemical Co.  
Order from Ellis Jones 901 794 0084, 800 888 5502  
[www.oldhamchem.com](http://www.oldhamchem.com)

Mop and buckets [www.libman.com2](http://www.libman.com2)

Tornado Mop (4 per case + 4 mop heads) #2030	\$ 14
Replacement head #2031	\$ 8

Leibman Co. call 800 646 6262, ext 116 for local sales.  
(Substantial discount over 1,000) KMart, Rite Aid, Stop-N-Shop, Giant

Buckets  
Rubbermaid Brute Double bucket #2617  
Call 800 810 7847

# Supplies

## Lead dust test kit

Box 500 tubes	\$ 99
1,000 wet naps	\$ 39
Chain of custody forms	no cost
Cost per sample sent in	\$ 8

Call Susan Jones for more information 301 643 2351

## Vapor barrier, epoxy system, weatherstripping and gasket

### Vapor barrier: for ground of crawl space

- Vapor barrier Teno Arm 8 mil 100' x 9' or 12' or 16' per sq ft	\$ 0.09
- Gasket: for back of inside stop (GG05) per sq ft	\$ 0.37

### Kerf fit nylon pile weatherstripping

- WS76 3/16" (pile height=1/16th in) 100 lin ft	\$ 109
---	--------

Glaze-ease elastomeric glazing, bedding glass, case of 8	\$ 80
--	-------

Resource Conservation Technology: 410-366-1146 / [www.conservationtechnology.com](http://www.conservationtechnology.com)

## Epoxy system

Penetrating Epoxy Sealer

Fill-it Epoxy filler

Smith & Co. 510 237 6842

## Plaster wall repair Nu-Wall 2035 has a perm rate of 3.5. and is approved by USDA for food handling facilities

- NU-WAL 2035: 160 sq ft 2 gallon container	\$ 47
1 roll 48" x 40'	\$ 19
480 sq ft 6 gallon container	\$ 132
1 roll 48" x 120'	\$ 48

Specification Chemicals Inc.: 1-800-247-3932 / [www.spec-chem.com](http://www.spec-chem.com) (free instruction video)

## Door mat

- Antimicrobial door mat (wholesale price, minimum 12 mats, plus shipping) \$30

Dr. Doormat, Inc.: 11140 Rockville Pike Suite 100, #233 Rockville, MD / 301-770-2002

Debbie@drdoormat.com / [www.drdoormat.com](http://www.drdoormat.com)

## Water resistant dry wall

- Dens Armor Plus (try to order by container or truck load)

1-800-327-2344 for distributor / 1-800-225-6119 for technical hot line

## Borate treatment

- New Orleans package containing:

22 Termite Pruf, 2 Roach Pruf, 2 applicators	\$ 147.60
--	-----------

Mix 1lb (1 container) with 1 gal. of water

We believe this is enough for joist, rafters and studs of one shotgun.

- Termite Pruf- 1lb	\$ 8.95 retail
---------------------	----------------

- Roach Pruf- 1lb	\$ 7.00 retail / 50@ \$3.32 each
-------------------	----------------------------------

Copper Brite Inc. / 805-565-1566

Window sash weights and pulleys  
[www.architecturaliron.com](http://www.architecturaliron.com)

#### Health and safety supplies

3M N100 respirator (with valve) each	\$ 7.25
3M N95 respirator (no valve) 20 for	\$ 16.72
Willson N95 respirator (with valve) 10 for	\$ 16.60
Tyvek suit (elastic wrists & ankles) box of 25 sizes?	\$ 85.00
Skid resistant shoe covers - case of 100	\$ 153.00
Eye wash station - 32 oz. bottles each	\$ _____
Spun bound poly suit case of _____	\$ _____

C&S Safety Systems of Louisiana 225 753 0018, [bill@candssafety.com](mailto:bill@candssafety.com)

#### Disposable suits

• Spun bound poly suit- case of 25	\$ 18.00
------------------------------------	----------

AramSCO 856 848 5330 Elaine Wax, ext. 304

#### PAINT

##### Encapsulant paint

• "Prepless" primer (120 sq ft per gal)	5 gallons	\$ 150.00
• Lead lock top coat (63 sq ft per gal)	5 gallons	\$ 150.00
	1 gallon	\$ 40.00

Global Encasement Inc.: 201-902-9770 / [www.encasement.com](http://www.encasement.com) / 1-800-266-3982

Best quality sash and trim paint (For a 20 years + paint job - no solvents or VOC's)

-Allback organic linseed oil paints, glazing, soap, and wax [www.solventfreepaint.com](http://www.solventfreepaint.com)

Viking Sales Inc. 585-924-8070 / [www.silentpaintremover.com](http://www.silentpaintremover.com) (expensive)

#### Lead paint solutions

For a 2 sample Lead Smart kit including necessary supplies and instructions call  
BTS Labs 800 604 1995 (\$35 per kit if you use Dennis Livingston's name)

For a comprehensive book on lead - Maintaining a Lead Safe Home in English or Spanish  
fax an order to 410 840 4689 or E-mail an order to [pat.dzierwinski@gmail.com](mailto:pat.dzierwinski@gmail.com) You will be billed for \$14.  
There are steep quantity discounts. The Spanish version is \$4 in any quantity

