

# Pakistan Shelter Guide

---

Design for improved  
flood resilience  
in Sindh

OCTOBER 2017



ARUP



# Foreword from NDMA

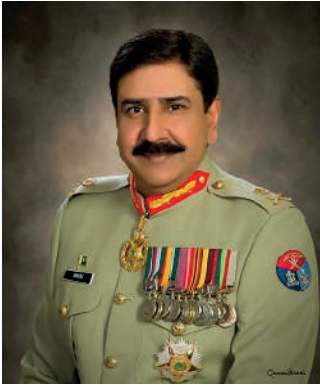

The primary goal of the National Disaster Management Authority (NDMA) is to achieve sustainable social, economic and environmental development in Pakistan through reducing risks and vulnerabilities by effectively responding to and recovering from all types of disasters.

Pakistan is among the countries most vulnerable to “naturally induced” disasters – both climate related and geophysical. The country’s acute vulnerability to disasters is due to its geographical locations, topography, hydrological configuration and extended fault-lines. Disasters induced by human actions, alongside natural disasters, have exacerbated the stresses on economy, poverty and the demands of sustainable development in Pakistan. The most vulnerable segments of the population have suffered grievously, most notably women, children, people with disabilities and people with age. Vulnerability to disasters is growing in both urban and rural areas, placing ever more lives and livelihoods at risk. The fact that vulnerabilities have profound implications on several socio-economic sectors, including shelter makes effective provisions of disaster management more significant.

The National Disaster Management Authority and the International organization for Migration have jointly worked on disaster management related projects and the state of emergency response preparedness. The crucial role of IOM as the lead agency, undertaking the comprehensive evaluation of shelter recovery designs implemented between 2010 and 2012 is clearly acknowledged by both Government and members of the Shelter Working Group. The overall aim of this research study is to conduct a scientific study on post-flood shelter projects in Southern Pakistan in order to develop guidance on flood-resistant shelter solutions that can contribute to building the resilience of communities living in flood-prone areas in southern province of Pakistan. The findings of this research have been used to produce this Construction Guide, which can be adapted into a training manual that can be used by operational agencies and highlights best practice in the planning, design and implementation of flood resilient shelter design in Southern Pakistan.

On behalf of the Government of Pakistan, I express my appreciation to IOM and UN partners for their joint programming, technical assistance and their continuous efforts to support Pakistan to strengthen resilience by providing upstream support and demonstrable models for service delivery, knowledge management products and evidence based researches. Collectively, we can contribute the efforts towards a Resilient Pakistan.

A handwritten signature in green ink, appearing to read 'Ommmm' with a long horizontal stroke extending to the right.

Lieutenant General

**Omar Mahmood Hayat, HI (M)**

Chairman, National Disaster Management  
Authority (NDMA)

# Foreword from IOM

Pakistan, and specifically the province of Sindh, has historically hosted an eclectic mix of vernacular traditions, cultural practices and people from diverse ethnic backgrounds. A generic practice such as construction of shelters has been enriched by availability of a variety of building materials including mud, loh-kat, bricks, cement and lime, and therefore, the nature of construction has been locally adapted given ground realities. Since 2010, the southern, low-lying areas of Pakistan have experienced large-scale flash flooding leading to inundation of villages, displacement of locals, and wide-scale destruction of locally built shelters. Estimates slate that around 1 million (805,694) families were displaced during 2010-12 and over 1.5 million shelters were damaged and destroyed because of flash flooding.

Given the rich heritage of vernacular building techniques in the Sindh province, it is no surprise that humanitarian organizations prioritized evidence-based modifications of existing techniques over use of industrial materials. As national lead agency for the Shelter in Pakistan, IOM has advocated for provision of resilient, low-cost shelter support to the most vulnerable families through use of vernacular and salvageable materials that minimize adverse environmental impacts. IOM, in coordination with its partners supported the construction of over 77,000 disaster-resilient one room shelters (ORS) in the worst affected areas of Pakistan, with Shelter Cluster partners supporting a further 450,000 shelters. Similar humanitarian responses which have prioritized use of vernacular materials, such as in the Philippines with Typhoon Haiyan and in Haiti after the 2010 earthquakes, have also supported construction of varying local typologies without any agreement on a single approach towards reconstruction.

Given the lack of evidence-based research comparing the different typologies used in Pakistan, IOM in partnership with Arup International Development and DfID Research Division commissioned a comprehensive evaluation of Shelter Recovery designs implemented between 2010 and 2012. Through empirical data collection and physical testing, the project aimed to provide scientifically tested guidance on low-cost shelter solutions that are flood resistant, compatible with vernacular architecture and indigenous construction techniques, and minimize environmental impacts while delivering the best value for money. During this study, key variables related to resilience, sustainability and local acceptability of different materials were put to test using simulated flood-water and rain-water testing tanks. The evidence presented herein is therefore the result of a concerted effort of the research team to provide reliable and accurate recommendations for future shelter projects.

It is my pleasure to share with you the final construction guide and research report which presents the results of rigorous empirical testing of the varying construction typologies used in southern Pakistan. We hope that this work can inform the work of governmental, non-governmental organizations, and local communities working on shelter solutions and encourages further collaboration and partnerships based on scientific learning and evidence. We thank all partners, particularly DfID Research Division, Arup International Development, the National Disaster Management Authority (NDMA), the Provincial Disaster Management Authority (PDMA) in Sindh, and Shelter Cluster partners for making this possible and continuing to find collaborative solutions to meet the needs of disaster-affected populations in Pakistan.



**Davide Terzi**  
Chief of Mission

International Organization for Migration (IOM), Pakistan

# Acknowledgements

The Pakistan Shelter Guide was developed with the support of the UK Department for International Development (DFID), DRR wing of National Disaster Management Authority, Pakistan (NDMA) and the International Organisation for Migration (IOM). However the views expressed in the report do not necessarily represent the views of the UK government or its official policies.

The Pakistan Shelter Cluster and Technical Advisory Group contributed invaluable feedback and criticism throughout the process. The authors would like to acknowledge the good faith nature of this collaboration which is critical to collective action in Sindh.

Special thanks to colleagues that remained engaged with the project from conceptualisation to conclusion: Magnus Wolfe Murray (Humanitarian Advisor DFID Pakistan), Ammarah Mubarak (Humanitarian Operations Manager, IOM Pakistan), Joseph Ashmore (Shelter and Settlements expert, IOM Geneva) and the IOM team that worked with the wide ranging counterparts to bring this together - Tya Maskun, Maria Moita, Manuel Pereira, Hasballah, Katherine Smalley, Amina Saoudi, Manahil Qureshi, Mahwish Irfan, Saad Hafeez, Zoe Nasim, Deeba Pervaiz, Abdul Hayee and Abdul Samad Agha.

Survey teams in Pakistan and the NED University helped to establish the evidence base which forms the basis of the Pakistan Shelter Guide and associated Research Report. In particular we would like to thank Peda International for coordinating the survey teams and NED University for establishing a new material testing facility as part of this research. Finally, our thanks goes to numerous colleagues at Arup and experts from other organisations who provided input and feedback on the analysis and evaluation of designs to improve flood resilience in Sindh.

## Comments and queries

If you have any comments or queries on the guidance we would love to hear from you. Please contact [sheltersupport@iom.int](mailto:sheltersupport@iom.int), [tim.white@arup.com](mailto:tim.white@arup.com) or [charlotte.mccarthy@arup.com](mailto:charlotte.mccarthy@arup.com)

# Contents

---

## ACKNOWLEDGEMENT

---

## INTRODUCTION

- 6 Background
- 8 Scope
- 10 Structure and Functionality

## 01

---

## DESIGN PRINCIPLES

- 12 **Safe and Resilient**
  - 12 Material Quality
  - 14 Water Resilience
  - 16 Stability and Integrity
  - 18 Buildability, Maintenance and Modification
  
- 20 **Acceptable**
  - 20 Comfort
  - 21 Space
  - 22 Protection
  - 23 Health and Safety
  
- 24 **Sustainable**
  - 24 Cost
  - 26 Local Supply Chain
  - 27 Natural Resources

## 02

---

## DESIGN DECISION TOOL

- 30 How to Use the Design Decision Tool
- 31 What wall should I use?
- 32 What roof should I use?
- 33 What foundations should I use?
- 34 Outline Design Evaluation
- 36 Detailed Design Variations

## **03**

### **DESIGN INFORMATION**

#### **39 Foundations**

- 39 Loh Kat (improved)
- 40 Loh Kat (basic)
- 41 Stabilised Mud / Adobe
- 42 Burnt Brick
- 43 Concrete

#### **44 Walls**

- 44 Loh Kat
- 46 Stabilised Layered Mud
- 48 Stabilised Adobe
- 50 Burnt Brick
- 52 Concrete Block

#### **54 Roofs**

- 54 Bamboo
- 55 Timber
- 56 Steel

#### **57 Detailed Design Variations**

- 57 Ring Beams
- 58 Windows and Doors
- 59 Raised Platform and Toes

## **04**

### **SUPPORTING INFORMATION**

#### **62 Material Specifications**

#### **72 Cost Estimates: Financial and Carbon**

#### **78 Notes Sheet**

---

# Introduction

# Background



Figure 01. Impact of flooding in Pakistan

Extreme and recurring flooding in southern Pakistan since 2010 has caused damage and destruction to more than 2.5 million homes, affecting in excess of 35 million people<sup>1</sup> in 78 districts (see Figure 02). The response to these floods has mobilised considerable resources, encompassed a wide range of stakeholders both foreign and domestic, and evolved over time. The scale and protracted nature of this ongoing disaster warrants a process of learning and reflection in order to improve the efficiency and impact of response.

In response, the Federal Government initially distributed an unconditional cash / compensation grant of up to US\$ 800 for flood affected families to support recovery. This constitutes the single largest investment by any stakeholder with a total cost of almost US\$ 1 billion. In parallel, it is reported that by mid 2014, at least 200,000 one room shelters were implemented by various shelter organisations in the flood affected districts. These shelters exhibit a wide range of designs, methodologies and costs. The general trajectory has been away from two room shelters (e.g. model villages built during the 2010 response) and toward a one room shelter typology<sup>2</sup>.

The one room shelter typology has been revised to

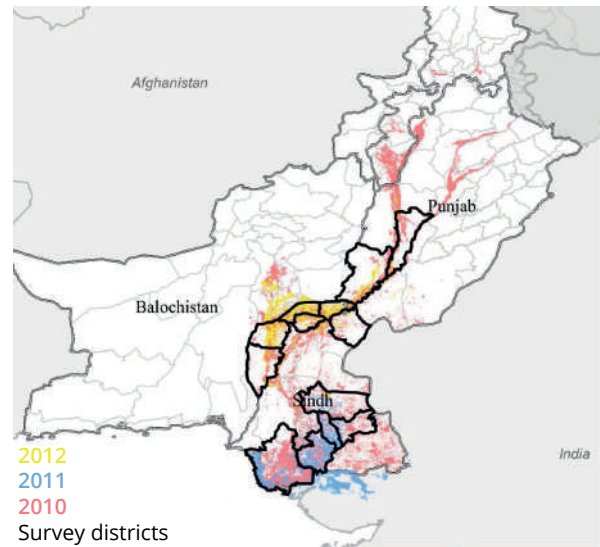

Figure 02. Map of recent flooding in southern Pakistan

encourage indigenous materials, vernacular construction techniques and ultimately reduce costs. Average costs are reported to have been reduced from US\$1,200 to US\$ 500 per unit. This has enabled twice as many units to be deployed for the same investment<sup>3</sup>. This scale of implementation is a notable achievement for all stakeholders involved.

However, it is estimated that the agencies response may have only reached 10% of the affected population, which leaves 90% of the affected population to self-recover. According to UNHCR and others, the self-recovery population have “rebuilt basic shelters using materials or methods that still leave them highly vulnerable to future floods.”<sup>4</sup> Achieving scale remains a central challenge to the ongoing response, recovery and reconstruction efforts across southern Pakistan.

In this context, the International Organisation for Migration (IOM) as the national lead shelter agency in Pakistan and with support from the United Kingdom Department for International Development (DFID), commissioned Arup in 2013 to conduct an independent research study to evaluate the effectiveness of the agency implemented shelters in order to inform a consolidated set of shelter designs and guidance on how to select an appropriate design for future shelter programs.

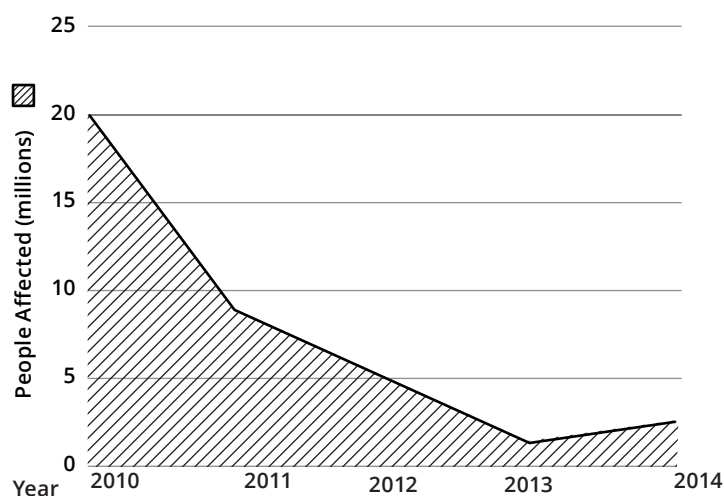

Figure 03. Impact of flooding in southern Pakistan

It is intended that this research should establish a scientific basis for evaluation and enable evidence based decision making for flood resilient shelter.

Southern Pakistan is also at risk of medium sized earthquakes and whilst outside the scope of the study the guide provides 'considerations' that would improve performance, however they do not constitute earthquake proof design.

This Shelter Guide and associated Research Report<sup>5</sup> are the culmination of extensive research including: data gathering; consultation with government bodies, agencies and residents; sample surveys of 800 shelters; physical testing of key design features; and analysis against the performance criteria (e.g. cost, structure, comfort, etc). Details of the research process and further detail about the evidence base produced by this research can be found in the associated Research Report.

The technical findings of this research primarily relate to material selection, performance and specification. This is a contribution to improving shelter in flood affected south Pakistan. However, there are other factors which must also be considered (e.g. hazard assessments and settlement guidelines). It is also acknowledged that the approach

to shelter assistance has changed over time and more effort is required to address self-recovery. It is strongly recommended that these other factors (especially hazard analysis, site selection/planning and enabling self-recovery) be included in future research and guidance to improve shelter in flood affected south Pakistan.

This research has been conducted in collaboration with the shelter working group organisations that are involved in implementing flood resilient shelter in southern Pakistan, and is supported by the National Disaster Management Agency (NDMA). The methodology is recognised as a best practice approach to support improved shelters designs that encourage flood-resistant, sustainable construction techniques in an effort to reduce the impact of flooding and build resilience of affected communities.

<sup>1</sup> UNHCR, IFRC & UN Habitat, 2014, Shelter Projects 2013-14

<sup>2</sup> Shelter Centre, 2014, Evaluation of the ORS Program

<sup>3</sup> Shelter Centre, 2014, Evaluation of the ORS Program

<sup>4</sup> UNHCR, IFRC & UN Habitat, 2014, Shelter Projects 2013-14 (page 63)

<sup>5</sup> Arup, 2017, Flood Resilient Shelter in Pakistan: Phase 2 - Evidence Based Research

# Scope



Figure 04. Shelter typologies (clockwise from top): loh kat, adobe, burnt brick, concrete block, burnt brick

## WHAT is this guide?

The guide presents a series of design principles, a user friendly design decision tool, and a library of recommended designs. All content is based on scientific evidence, physical testing, surveys, and expert analysis. The guide is intended to support improved decision making in the design of shelters and shelter programs in an effort to enhance flood resilience. The guide provides construction tips and notes.

While there may be broader applications of the guide, its specific purpose is to inform best practice in the planning, design and construction of flood resilient 'One Room Shelters' in southern Pakistan. The guide is primarily intended for use in the post disaster context, but is also applicable for disaster risk reduction planning. In this context, the term shelter is used to describe semi-permanent one room houses with a design life of five to fifteen years.

Key Pakistan Shelter working group organisations collaborated in the development of the guide, and this process has been encouraged by the National Disaster Management Agency (NDMA).

.....  
<sup>6</sup> Heritage Foundation, 2011, Build back safer with vernacular methodologies: DRR-driven post-flood rehabilitation in Sindh

<sup>7</sup> Shelter Centre, 2014, Evaluation of the ORS Program

<sup>8</sup> Shelter Centre, 2014, Evaluation of the ORS Program  
 .....

### **WHY is the guide needed?**

The scale of the disaster and response in southern Pakistan has resulted in a wide variety of approaches to shelter. This is potentially very beneficial as it provides flexibility, but there is evidence of duplication and inefficiencies<sup>10</sup>. Therefore, the guide seeks to provide a consistent approach across sector actors.

Similarly, a wide range of technical solutions have been implemented in southern Pakistan. Some of these techniques were un(der)tested<sup>6</sup>. The surveys conducted as part of this research reveal significant inconsistencies and examples of underperformance. Therefore, this guide seeks to provide an evidence based approach to decision making.

An important sub-set of these technical solutions was a concerted effort to include Disaster Risk Reduction (DRR) measures in 50% of all shelters.<sup>7</sup> The surveys and physical testing conducted as part of this research identify severe underperformance of several DRR measures. In effect, additional funding and expectations were assigned to deficient technical solutions.

Therefore, this guide seeks to reduce the risk of inadequate or ineffective resilience measures being implemented.

Unsurprisingly there have been observations and complaints about the equity and transparency of the disaster response<sup>8</sup>. This guide seeks to outline an objective and transparent decision making process in an effort to reduce the risk of hostility from residents due to perceived unfairness.

### **WHERE & WHEN should the guide be used?**

While much of the research, analysis and recommendations presented here are widely applicable in Pakistan and beyond, the guide is specifically for flood resilient one room shelters in flood affected south Pakistan.

The anticipated primary use of the guide is during the emergency response and early recovery phases, which is generally the first six to nine months, of the humanitarian response. However, these time lines will vary and the inherent nature of flooding makes it difficult to identify day zero of the response. The guide should also be useful for development agencies and can be applicable to pre-disaster risk reduction programs.

### **WHO is the guide for?**

The guide is primarily for technical or program personnel and organisations responsible for the design, planning and implementation of shelters and shelter programs. It may also be a useful reference for government departments, policy makers, contractors or builders and design consultants. The guide is not intended for use by residents or homeowners of shelters but has benefited from, and been informed by, consultation with residents and homeowners. However, it can be assumed that the recommended designs will be used by residents and homeowners. There may be opportunities to develop additional guides, tools and training for other audiences in the future, e.g. a construction guide or training aimed at local builders and craftsmen to enhance the quality of material selection and workmanship.

### **LIMITATIONS of the guide?**

The guide is not a program planning or program design guide. It does not include guidance on the different implementation approaches, and does not include recommendations regarding direct cash contribution, materials provision, the level of beneficiary input, level of construction monitoring etc.

The guide is not a building code or regulatory document. It does not attempt to supersede any existing regulatory processes but may hopefully influence future revisions to the regulatory framework.

The guide does not include specific guidance or performance standards for seismic design. Seismic loads would need to be factored into the requirements for all shelters, and their designs adjusted accordingly, for all areas exposed to seismic hazards. Some considerations are presented within the design information in chapter three to improve the seismic performance in comparison to the baseline design but these considerations are by no means meant to make the shelter "earthquake-proof".

The guide does not include site selection or site planning guidance which could mitigate site specific risks, e.g. flooding. A variety of hazard assessment methodologies are available that could be used to determine the risk profile and geo-spatial hazard locations which would assist in overall site selection. Village or neighbourhood level site planning guidance should also address non-shelter items (e.g. community facilities, roads etc).

The guide cannot prevent flood damage and the designs included do not attempt to do so. However, the designs are intended to increase resilience to flooding by reducing the damage caused. It is strongly recommended that further research, to complement this guide, be conducted in relation to hazard analysis, site selection/planning and enabling self-recovery.

# Structure and Functionality

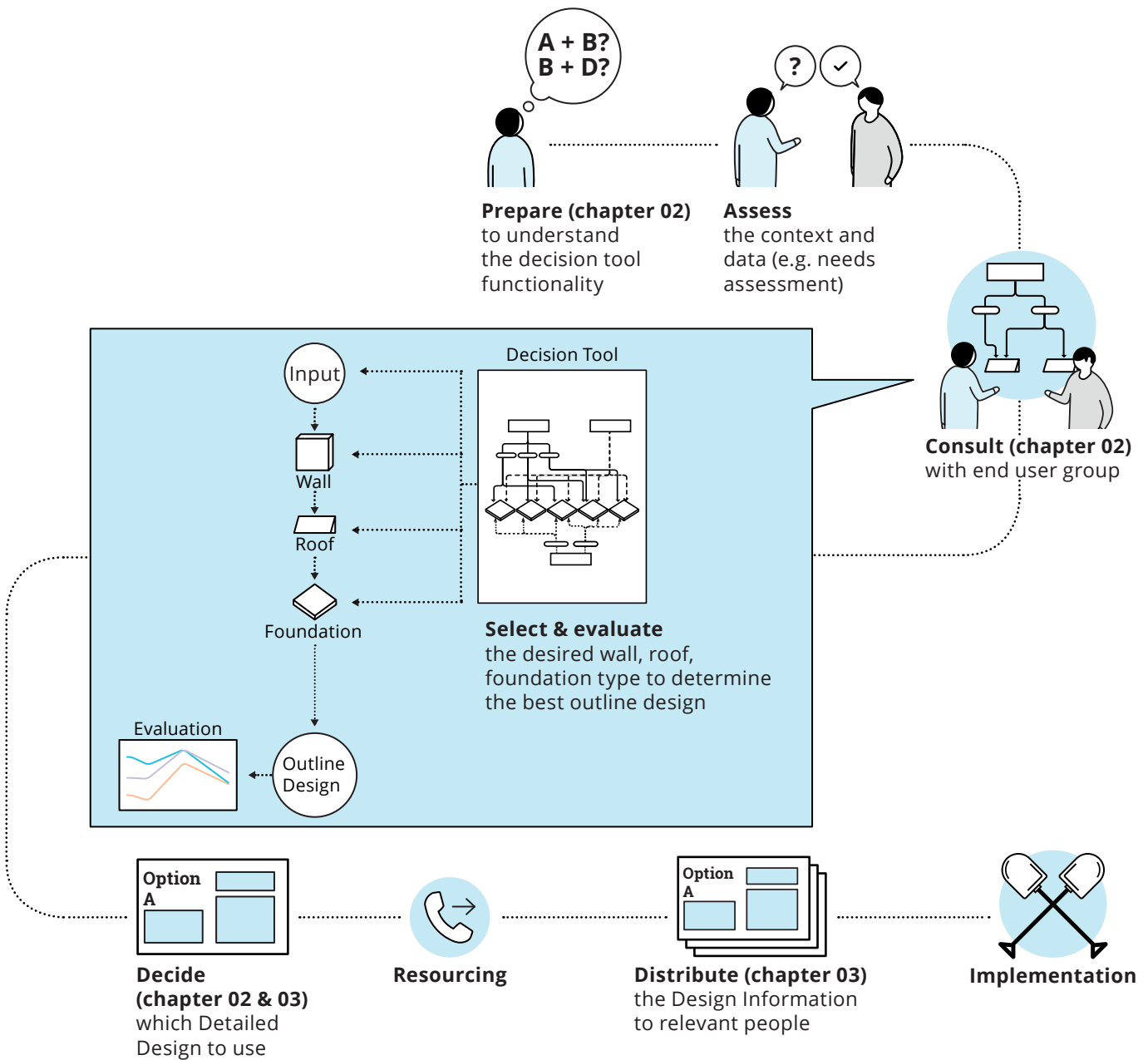

Figure 05. User journey and functionality of the shelter guide Compatibility

The guide is organised into four main chapters. The first chapter, design principles, explains the high level considerations which govern the performance of shelter and upon which the recommendations of the guide are based. The design decision tool is the second chapter which guides users through the process of selecting an appropriate shelter design by making informed decisions. Outline design options are identified by answering several key questions. Decisions on outline and detailed designs can be made based on a performance criteria assessment of each component.

The third chapter, design information, provides a library of flood resilient shelter design components which can be combined into a detailed shelter design package. The final chapter, supporting information, provides references and additional information to complement the guide.

The guide functions differently depending on the user, purpose and setting. It can be read in isolation for general knowledge and to improve understanding of the topic by program designers, policy makers and those generally interested in shelter. The practical user, notionally a technical or program officer within an agency, can read the guide in isolation to improve general knowledge of the topic, but can also extract the design decision tool to guide discussion and decisions in the field. For the researcher, the technical guidance and assessments are referenced throughout the guide to encourage and enable further testing and analysis in an effort to re-evaluate and expand the evidence base.

Linkages between chapters, to the research report and external resources are highlighted throughout to enable fluid use of the guide by all users.

# 01

---

# Design principles

---

This chapter introduces the fundamental design principles which contribute to the performance of one room shelters in flood affected south Pakistan. The principles are framed by the key performance criteria which are 'Safe and Resilient', 'Acceptable'; and 'Sustainable'. The significance of the performance criteria are explained with examples of how the criteria relate to the designs and key construction details. Within each criterion there are several indicators which have been used to quantitatively and qualitatively inform the design principles and design information. The design information in chapter three is evaluated against these criteria to support the comparison and selection of designs. The most significant principles in this evaluation relate to durability, water resilience, buildability, capital cost and life cycle cost (financial and carbon).



# Safe and Resilient

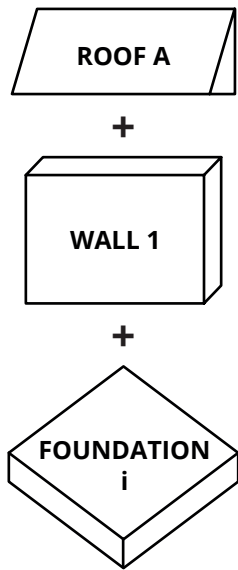

Figure 06. Compatibility

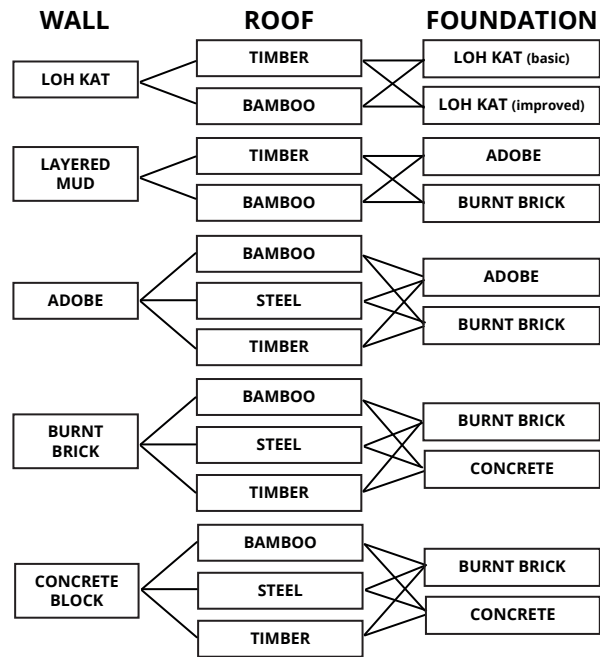

Figure 07. Compatibility tree

## Material Quality

### Compatibility

Materials and components must be compatible so that individual elements do not undermine the performance of the component or overall design. The surveys reveal several incompatibilities, e.g. mud foundations with burnt brick walls which undermine the overall performance of the design as mud foundations do not have the water resilience to adequately support brick walls<sup>9</sup>, thus undermining the flood resistance of the walls themselves. The designs in this guide only use compatible materials within and across components of walls, roof and foundations. The compatibility tree indicates which components can be used together and which should not

(see Figure 07).

### Durability

Durability influences the overall life span of the shelter and maximises the benefit of the initial capital investment. Roofing was the main durability concern identified in the surveys, with 28% of shelters exhibiting some form of damage to the roof structure. The most common problem was insect attack of timber and bamboo elements which affected 21% of shelters<sup>10</sup>. In particular, the common treatments for bamboo are inadequate and may result in a life span of less than one year<sup>11</sup>. Specifications for material treatment to improve durability are included in chapter four.

Similarly, construction detailing can greatly improve durability, e.g. bamboo and timber should not be cast directly into the ground. The designs in this guide include guidance on appropriate construction detailing.

<sup>9</sup> See Research Report section 6.1

<sup>10</sup> See Research Report section 6.1

<sup>11</sup> Kaminski, S., Lawrence, A., Trujillo, D. and King, C. (2016) Structural use of bamboo. Part 2: Durability and preservation. The Structural Engineer, volume 94 (10): 38-43

<sup>12</sup> See Research Report section 6.1

**KEY RECOMMENDATIONS: MATERIAL QUALITY**

1. Materials and design components (i.e. walls, roofs, foundations) must be compatible (see Figure 07).
2. Materials must be adequately specified, treated to ensure full potential design life, carefully detailed, and strength tested on site to ensure performance (see specifications in chapter four).
3. Soil stabilisation is cost effective, environmentally friendly and can be flood and rain resilient, but it requires specialist training.



Figure 08: Example of low strength wall



Figure 08a: Soil testing

**Specification and Strength**

Materials should be adequately and appropriately specified. Many of the agency design packages received and reviewed by Arup did not include material specifications. Chapter four of this guide includes specifications for the materials used.

Material strength is a pivotal consideration for any structure. However, few of the reviewed agency designs included minimum material strengths<sup>12</sup>. This guide adopts material strength recommendations based on the following building codes: Uganda, Kenya, Mexico and Eurocode. In addition, material testing for a variety of mud components was conducted at NED University and these results inform the overall material strength recommendations in chapters three and four.

This guide acknowledges that on site material testing may not be very practical or accurate, but several simple tests are recommended in chapter three. For agencies involved in larger scale programmes and procurement, it is recommended that quality checks be conducted at source.

**Stabilisation**

Earth construction is soluble in and easily eroded by water unless it is 'stabilised', whereby it is mixed with lime or Portland cement in ratios between 5% and 10%.

Stabilising soil construction improves flood and heavy rain resilience, making it stronger and more durable. Physical testing has shown that a 4ft flood can be resisted without collapse and that the heavy rain of 2011 can be resisted with minimal or no repairs required. Soil construction should be stabilised up to at least the same level as the maximum previous flood (or likely future flood).

Lime is cheaper than Portland cement, whilst Portland cement is easier to use as it requires less testing. Both lime and Portland cement stabilised soil are significantly cheaper and contain less embodied carbon than fired brick and concrete block.

Soil stabilisation is a science with training in soil suitability, mixing, curing and testing all critical to success. For example different soils are suited to either lime or Portland cement stabilisation and in order to understand whether the stabilisation process has been effective testing is essential, with the best way to do this is to simply place a stabilised soil block in a bucket of water.



## Water Resilience

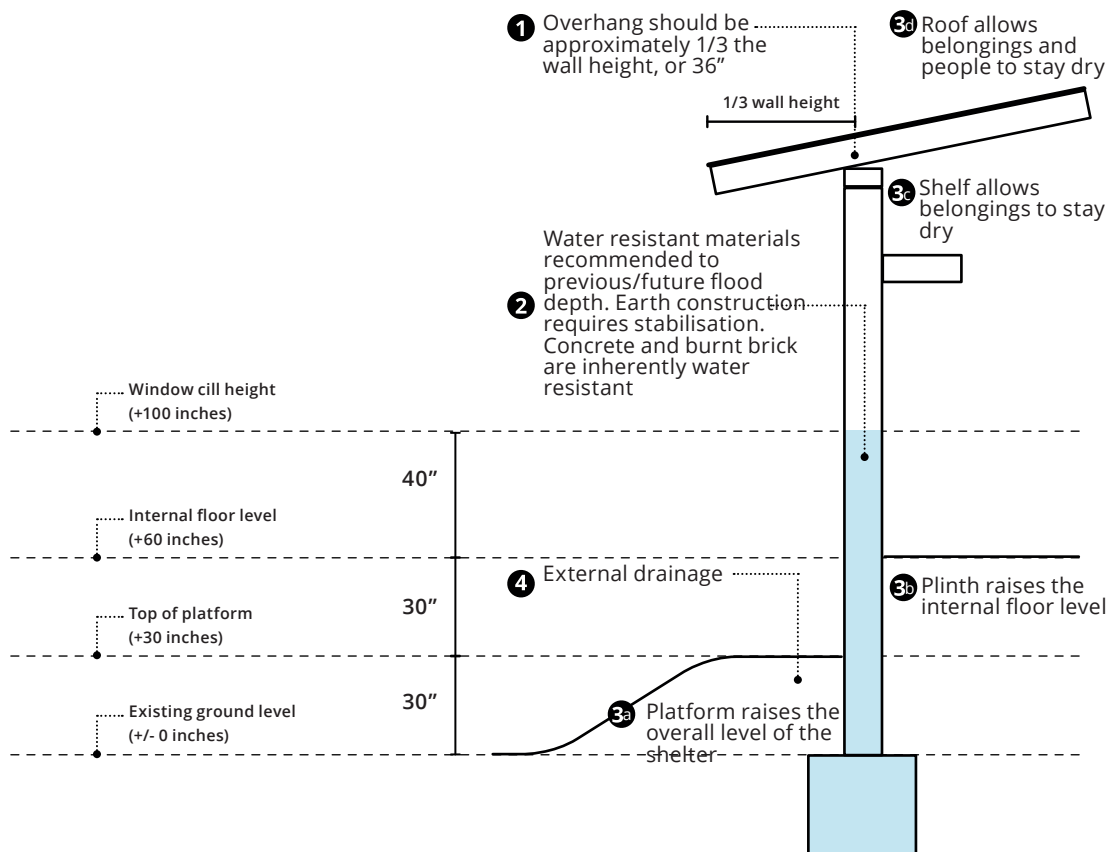

Figure 09. Water resilience for load bearing construction (left) and loh kat construction (right)

Water resilience and flood resistant design are intended to improve the long term performance and ongoing functionality of shelters in response to rainfall and flooding (immersion).

The approach to flood protection ranges from 'avoid' to 'mitigate' to 'accept'. Avoid is the preferred approach as it removes risk by appropriately siting the shelter away from a flood zone. This approach is based on a probabilistic hazard assessment which does not exist for flooding in southern Pakistan. Moreover, this guide does not address site selection so flooding cannot be avoided. 'Mitigate' attempts to address flood protection by designing in features which can reduce or alleviate the impact of flooding. 'Accept' simply acknowledges that flooding will occur, poses a high risk to the shelter and may destroy it.

This guide adopts an approach between 'mitigate' and 'accept'. In the absence of a probabilistic hazard assessment, a key consideration is to understand the level of previous floods in the area. If extreme flooding (e.g. 10' above ground level) is common, the guide recommends 'avoid' whereby the shelter should not be built, or 'accept' whereby an extremely low cost shelter could be built but will most likely be destroyed in the next serious flood.

In the absence of extreme flooding, the guide recommends a series of designs which can mitigate flood impact and the user can navigate the design decision tool to identify the most appropriate shelter design.

The principles and key features of flood resilient design recommended by this guide adopt the 'hats and boots' approach which provides roof overhang protection and enhanced protection of the lower walls and foundations.

**KEY RECOMMENDATIONS: WATER RESILIENCE**

1. Roof overhang should be approximately 36" or one third the height of the walls
2. Water resistant materials used for foundations and walls to a height which corresponds to the future flooding level. Earth construction requires stabilisation. Concrete and burnt brick are inherently water resistant.
3. Raise the internal flood level to provide a usage space for storing belongings in the event of a flood. A platform provides an external dry area.
4. Surrounding ground level is sloped away from the shelter for drainage.

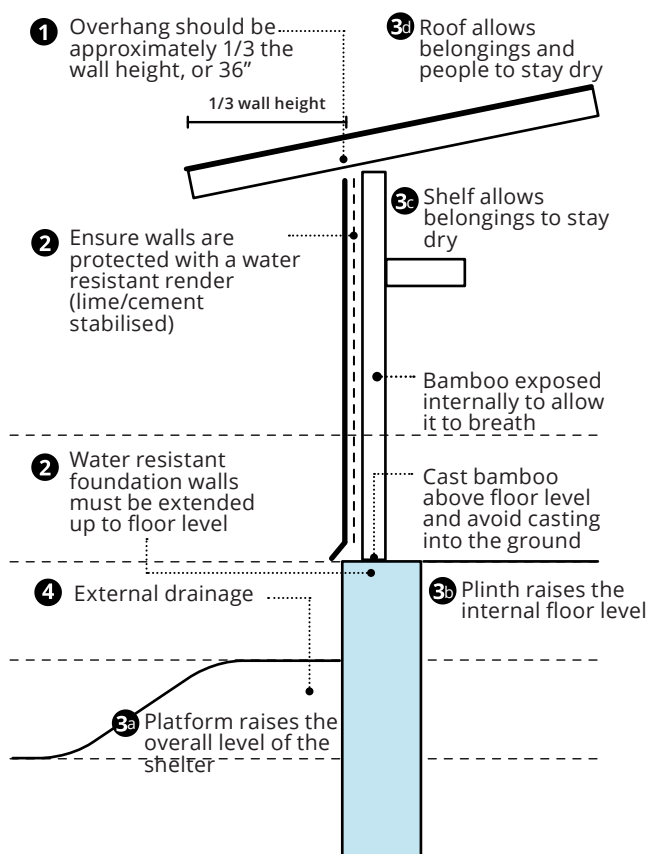

**1 Roof Overhang: Rain**  
 36" overhang required in all designs to protect the roof structure, roof to wall connections, and the upper wall from rainfall

**2 Water Resistant Walls: Rain & Flood**  
 Walls built using water resistant materials required in all designs to withstand extended periods of immersion. Each wall typology achieves this in different ways

**3 Plinth & Platform: Flooding**  
 To maintain the use of the shelter during flood events. Platforms (3a) can be built under the shelter. Plinths (3b) are within the structure and raise the internal floor level. Shelves (3c) and roofs (3d) allow belongs and people to stay dry

**4 External Drainage: Rainfall**  
 Area surrounding the shelter is required to slope away from the building to protect from water infiltration and ponding

**2 Water Resistant Foundations: Flooding**  
 Foundations built using water resistant materials required in all designs to withstand extended periods of immersion.

The analysis and physical testing inform recommendations presented in the diagram above.

For maximum protection, in areas where flood levels are likely to be high or unpredictable, the entire wall should be made of water resistant material, to ring beam level.

External drainage should be complimented with consideration for appropriately siting the building, and providing local drainage that accommodates other nearby structures and access routes. This site selection and planning is not included in the scope for this guide.

Raised platforms and plinths will require additional foundation and/or wall build up as the base of the foundations must still be below existing ground level on firm soil. Field surveys indicate that raising the floor 60 inches above existing ground level would enable the shelter to remain functional in 80% of cases.



### Stability and Integrity

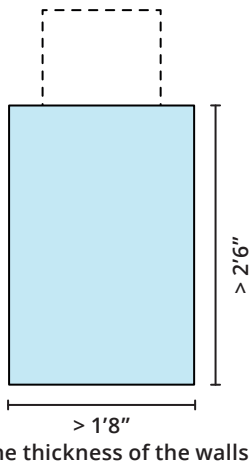
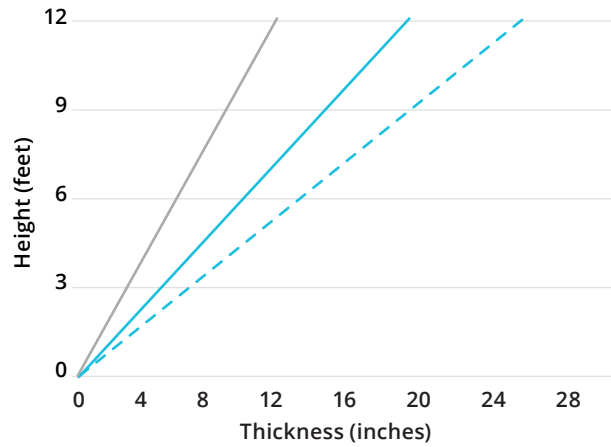

Figure 10. Foundation dimensions

### Foundation Dimensions

All structures require appropriate foundations to transfer loads to and from the ground. The required foundation dimensions fundamentally depend on the nature of the sub soil and the design load. Our review of the agency drawings and as built surveys indicates that existing foundations are generally adequate for hard soil conditions. As such this guide recommends that foundations for hard soils should be at least 2'6" deep for all material types except loh kat which is 1'8" deep. However, these dimensions may not be adequate for soft soil types and we recommend that once the minimum foundation depth has been reached, the base of the excavation is checked in order to ensure that hard soil is reached<sup>13</sup>. For clays it should take some effort to press a thumb into the ground, for sand digging with a shovel should be difficult. This may result in considerably deeper foundations.

The surveys revealed that in all cases, except for loh kat, the average foundation width is less than the minimum required. This guide recommends that foundations should be at least 500mm wide and never less than the thickness of the walls (see Figure 10).



Ensure the height and thickness of the wall is below the lines plotted in the graph for each material type

- Layered Mud
- Adobe
- Burnt Brick & Concrete Block

Figure 11. Recommended wall thickness and height for each material based on length not exceeding 19 feet

### Wall Dimensions

The structural limits of a wall's length, height and thickness are a result of the material used to build the wall. In general, the longer or higher the wall, the thicker it needs to be. Our surveys and analysis consistently identify walls of inadequate thickness. In particular, concrete block and layered mud walls were overly slender (i.e. too long or tall for the thickness of the block)<sup>14</sup>. There is no uniform guide, or slenderness ratio, for all the wall types recommended in this guide as they vary by material. The slenderness limits for the four masonry-type materials (layered mud, adobe, burnt brick and concrete block) are highlighted in Figure 11. Loh Kat does not have a slenderness ratio as it is designed as a frame. The graphs below indicate the required thickness of walls relative to their height or length depending on the material used. The recommended designs in chapter three satisfy these slenderness rules.

The recommended designs satisfy the most rigorous requirements for maximum window sizes as detailed in the Research Report (Section 6.2). Layered mud is the most constrained material and this window size, which is adequate for daylighting levels, is used throughout the guide.

For Loh Kat walls, spacing of 600mm between vertical poplar or bamboo poles is adequate. At the corners, diagonal cross braces are provided to give stability to the structure.

**KEY RECOMMENDATIONS: STABILITY & INTEGRITY**

1. Foundations are at least 2'6" below existing ground level, on firm soil, and at least 1'8" wide but not less than the width of the walls
2. Wall thickness must be individually assessed based on length, height and material
3. All elements are tied together and connected to adjacent elements, especially ring beams and roof to wall connections
4. Roofs must withstand the dead and live design loads, allowing for the roof to be saturated by heavy rain and used as a place of refuge.
5. Roof should maintain a minimum 5 degree pitch

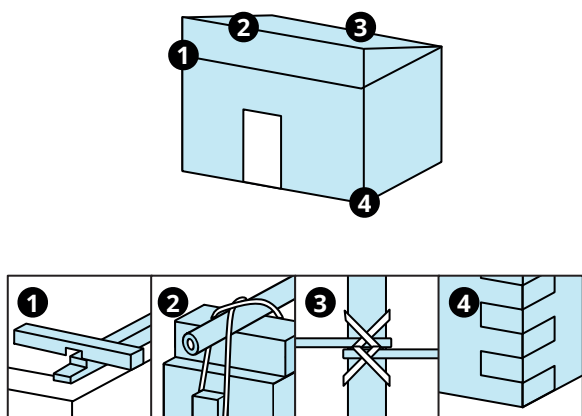

Figure 12. Important connections and tie points

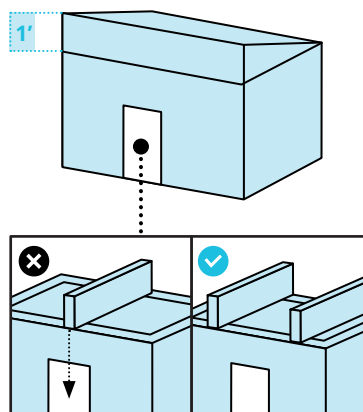

Figure 13. Roof pitch and location of structure

**Connections and Tying**

All construction elements should be connected or tied to the adjoining construction element in order to ensure adequate structural load transfer, durability and security. Our analysis reveals that in existing shelters the wall to roof connection is generally inadequate as 66% of surveyed shelters reported the roof had lifted off in high winds<sup>15</sup>. There are other potential weak connections and ties at the wall and foundation corners, where verandas are attached to the main structure, the absence of ring beams, and the internal connections within ring beams<sup>16</sup>. Note that as a framed construction technique, loh kat has a ring beam embedded in its design and construction. The designs recommended in this guide include the following principles (see Figure 12):

- 1 Ring beams with internal connections included by default in all designs.
- 2 Demountable wall to roof connections to resist wind loads but allow the roof to be relocated.
- 3 All roof and wall members are internally tied.
- 4 Brick bonds which connect between wall leaves and courses.

**Roof Capacity**

Roofs should be designed and built to accommodate the inherent dead load in dry and wet conditions, and any potential live loads (e.g. people accessing the roof). This guide recommends a design dead load of 2.5 kPa and an additional 0.6 kPa to accommodate the live load of people accessing the roof.

A concern identified in the surveys is water logging of roofs which is mitigated in the recommended designs by including a minimum pitch of five degrees in order to prevent water ponding (see Figure 13).

Another concern is the location of wall openings relative to the roof structure. In principle, the primary roof joists should not be placed above openings. Instead they should bear onto solid wall panels in order to ensure maximum bearing capacity (see Figure 13).

<sup>13</sup> See Research Report section 6.2

<sup>14</sup> Ibid

<sup>15</sup> Ibid

<sup>16</sup> Ibid



## Buildability, and Modification

## Maintenance



Figure 14: Example of adobe wall in need of repair



Figure 15: Example of flood damage to loh kat shelter

## Communication

Design information must be intelligible to the intended audience. A strong correlation exists between mistakes, problems and defects in the shelters surveyed and the information communicated in the design packages. Our review indicates only 10% of agency design packages are considered 'complete'. The missing information primarily relates to the location of windows and doors, spacing for roof purlins or joists, not providing a thickness for mud roofs, and not showing connections between members<sup>17</sup>. All design packages should fully communicate the information required for construction. The designs included in this guide are considered to include all relevant information for design decisions but would need additional information in order to produce a complete construction design package.

## Building techniques

Designs must be buildable within the context for which they are intended. Using construction defects as a proxy for build ability, our surveys indicate that loh kat is a challenging building technique as 20% of shelters exhibited defects in the form of gaps in the walls<sup>18</sup>. However, these defects may not be the result of build ability. The ORS evaluation indicates that increased or improved training in construction should be more practical and would potentially improve build ability<sup>19</sup>. The designs recommended in this guide are all based on building techniques commonly found in southern Pakistan which should enable them to be built within the existing context.

## Tools

The availability and ability to use the required tools is essential for the successful implementation of any design. The tools required to build and maintain the shelters envisaged in this guide are widely available. Surveys recorded that 74% of shelters can be repaired or modified with locally available tools and in general, the availability of tools was not cited as a limiting factor<sup>20</sup>. This guide uses construction techniques for which tools are widely available in southern Pakistan. However, work by the Heritage Foundation, the results of the one room shelter evaluation and our own surveys indicate that lime processing is a challenge for individual families and is better suited to a group of builders or a collection of households<sup>21</sup>.

## Skills and Training

Training is generally required and should be specific to the required construction techniques. The surveys revealed a correlation between low levels of training in loh kat (43%) and high rates of construction defects<sup>22</sup>. While this may not be a causal effect, there is obvious room for improvement. The vast majority of training was well received. However, training for maintenance and repair was generally not conducted<sup>23</sup> and this is recommended as part of this guide in order to extend the life span of shelters and maximise the investment made. There is no evidence that training programmes have resulted in improved livelihoods for residents<sup>24</sup> and therefore, this rationale is not included in this guide.

**KEY RECOMMENDATIONS:  
BUILDABILITY, MAINTENANCE AND MODIFICATION**

1. Ensure the construction documents include all information required to effectively communicate the design intent (see checklist in Research Report)
2. Ensure the building techniques and tools are appropriate, available, and their use is understood
3. Promote the ongoing maintenance and repair of shelters which should include training
4. Allow for the inevitable extension of the shelter which will most likely be a veranda

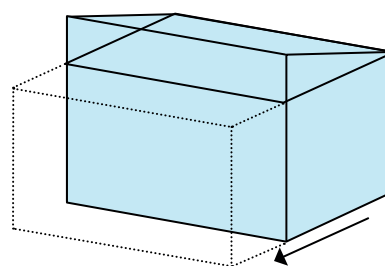

Figure 16. Future expansion

### Maintenance and repair

Maintenance and repair are essential for the ongoing functionality of a building and can greatly expand the building life span and therefore the impact of the capital investment. According to our surveys, repairs are generally considered to be difficult with the availability of local materials cited as the most challenging aspect of ongoing maintenance and repairs. Walls and roofs are the most common elements which require repair. The main difference is frequency of repair with concrete block, burnt brick and steel roof shelters requiring half the frequency of repairs compared to adobe/mud brick, layered mud or loh kat. However, burnt brick and concrete block are more likely to require skilled labour to maintain<sup>25</sup>.

The consideration of frequency versus complexity of repair is factored into the decision making tool in chapter two. While the relative cost of these repairs is addressed in the section below on sustainability where the capital costs are compared against the life cycle cost.

### Modifications

Shelters must be modifiable and will be modified anyway so this should be designed in from the outset as much as possible. The surveys indicate that very few shelters have been modified to date but may well be in the future. The most common modification is the addition of a veranda. Furthermore, it was reported that many residents would like to add a veranda in the future. The safe addition of a veranda should be factored into the design of all shelters. This guide includes recommendations on how this could be achieved by including wooden fixing guides in the entrance wall.

<sup>17</sup> See Research Report section 6.2

<sup>18</sup> See Research Report section 6.4

<sup>19</sup> Shelter Centre, 2014, Evaluation of the ORS Program

<sup>20</sup> See Research Report section 6.4

<sup>21</sup> Shelter Centre, 2014, Evaluation of the ORS Program

<sup>22</sup> See Research Report section 6.4

<sup>23</sup> Shelter Centre, 2014, Evaluation of the ORS Program

<sup>24</sup> Ibid.

<sup>25</sup> See Research Report section 6.4



# Acceptable

## Comfort

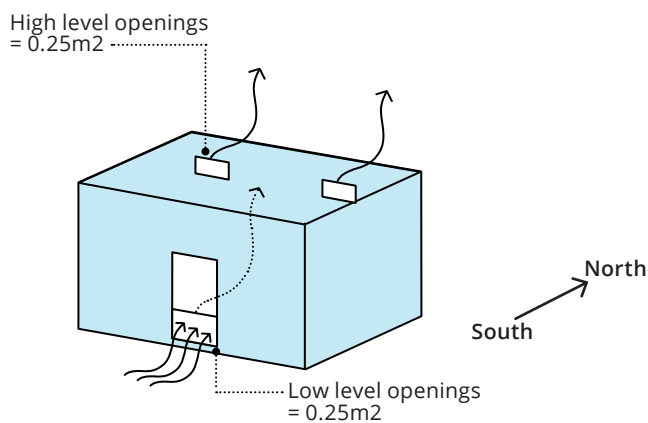

Figure 17. Ventilation

### Thermal

The internal air temperature of the shelters should be equal to, or below, the shaded external temperature. Our analysis confirmed the survey results which indicate that wall typologies, and window sizes have no significant impact on thermal comfort. Internal air temperatures are generally comparable with shaded exterior temperatures as a result of doors being open and the small size of these shelters<sup>26</sup>.

Our analysis indicates that thermal comfort is driven by air flow (ventilation) which could be improved by the provision of two ventilation openings on opposing walls of the shelter. For optimum cross ventilation performance, these openings should have a combined area of least 2% of the floor area, be one high and one low on the vertical plane of the wall, and be located on the north-south walls of the shelter (see Figure 17). Additional thermal gains can be achieved with thicker walls and roofs, however the impact of this is small.

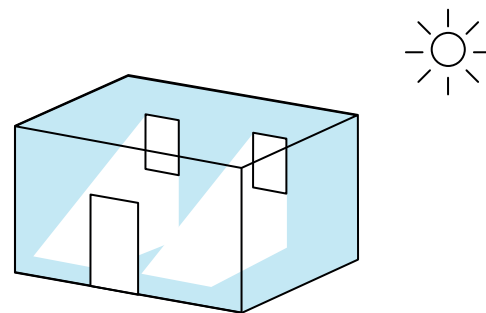

Figure 18. Lighting

### Lighting

Internal lighting should be adequate for normal daily functions, e.g. eating. The existing lighting conditions were not reported in the surveys nor identified in our analysis as being below adequate levels<sup>27</sup>. Therefore, lighting is not considered a significant driver of any design modifications.

However, several recommendations are incorporated into the designs within this guide (see Figure 18):

- One window (approx. 3' x 3') provides adequate natural lighting 70% of the time. Two windows of similar size provide adequate lighting 100% of the time.
- A light coloured internal paint can improve daylighting by 30%.
- Openings should be inherently private and secure by design for efficient use and not simply blocked up as was noted in numerous surveys.
- Jali screens or other similar 'built in' windows only reduce daylighting by 5-15% while still being secure.

## Space

### KEY RECOMMENDATIONS: COMFORT & SPACE

1. Orientate the long walls of the shelter on an east-west axis
2. Low level ventilation openings of 0.25sqm (these can be out into the door)
3. Minimum of two secure windows (approx 3' x 3' each) on the wall opposite the door. High level ventilation openings, of 0.25sqm, are required (these can be placed above the window)
4. Floor area of 21m<sup>2</sup> based on average family size (3.5 sqm per person)
5. Rectangular floor plans with no internal partitions

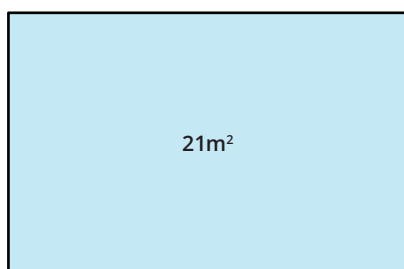

Figure 19. Assumed floor plan for a household of six people

### Size

Shelters should meet minimum floor space requirements set at 3.5 sqm per person by the Sphere Handbook<sup>28</sup>. Only 48% of surveyed shelters meet or exceed the sphere indicators. 24% of people stated they could not use the shelter as they like and the primary reason for this was lack of space<sup>29</sup>. Whilst there are arguments for more or less space per person this guide assumes a floor area of 21m<sup>2</sup> based on an average occupancy of six people (see Figure 19).

### Layout and Flexibility

While the shelters are small, their layout should accommodate and respond to cultural use. The primary functions attributed to the shelters are sitting, sleeping and storage. In a few cases, they are also used for worship, family gatherings and sewing/handicrafts. In terms of internal organisation or flexibility, there was considerable debate about one or two room shelters in the early stages of the response in 2010<sup>30</sup>. From our surveys, the existing one room shelters appear to adequately support their desired use as the vast majority of respondents did not identify any other activities for which they would like to use their shelters<sup>31</sup>.

In terms of layout, field surveys found the vast majority of shelters to be rectilinear. In our survey, only one out of 800 shelters were circular in plan<sup>32</sup>. We note that the Heritage Foundation have discontinued circular plan shelters<sup>33</sup>.

Thus, this guide recommends rectilinear shelters with no internal partitions which should continue to adequately serve the requirements of residents.

<sup>26</sup> See Research Report section 7.1

<sup>27</sup> Ibid.

<sup>28</sup> Sphere Project, 2011, The Sphere Handbook

<sup>29</sup> See Research Report section 7.2

<sup>30</sup> Shelter Centre, 2014, Evaluation of the ORS Program

<sup>31</sup> See Research Report section 7.2

<sup>32</sup> Ibid

<sup>33</sup> Heritage Foundation, 2011, Build back safer with vernacular methodologies: DRR-driven post-flood rehabilitation in Sindh

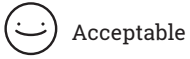

Acceptable

## Protection



Figure 20. Window conditions vary from insecure and exposed to secure and private

### Security

Shelters should provide adequate security for personal protection and the safe storage of valuables. Overall, survey respondents (both male and female) felt secure in their shelters. The lack of doors and windows were cited as the primary reasons for not feeling secure<sup>34</sup>. Therefore, this guide recommends that all shelters should include windows and doors. The fragility of loh kat walls and certain roof types (plastic, chicks, mud) were secondary reasons for perceived insecurity. It should be noted that burnt brick performed significantly better than all other construction typologies in terms of perceived security<sup>35</sup>. There is no technical solution to perceived security concerns and this guide does not attempt to change people’s perceptions of security. Therefore, security is factored into the key questions of the design decision tool in order to align security concerns with other (non loh kat) construction techniques.

### Privacy

Shelters should provide adequate privacy for normal daily life to be conducted as desired. In general, the overwhelming majority of survey respondents felt their shelter was private. However, there is a notable difference between male (75%) and female (63%) perceptions of privacy. The primary reason for lack of privacy was identified as visibility through openings<sup>36</sup>. As with security above, the inclusion of windows and doors would mitigate these concerns. Therefore, this guide recommends the use of lockable doors, and windows which are operable and lockable (e.g. timber shutters) or inherently secure (e.g. jali screens or ‘hit and miss’ brick work) (see Figure 20).

### Internal Air Quality

The internal air quality should be similar or better than the external air quality. The primary concern identified in this research relates to 15% of survey respondents who report having an open fire inside the shelter. Curiously, a disproportionate number of these respondents live in loh kat shelters which may reveal a correlation to income levels, however, this cannot be ascertained in the data<sup>37</sup>. While an indoor stove could potentially be accommodated by introducing a 200mm diameter flue with permanent vent, this is a considerable additional cost and material that may not be available for a very limit number of cases. It is noted that the Heritage Foundation are promoting an external stove system rather than an internal one<sup>38</sup>. Therefore, this guide recommends that cooking should happen outdoors and this will ensure internal air quality stays within acceptable parameters.

<sup>34</sup> See Research Report section 7.3

<sup>35</sup> Ibid

<sup>36</sup> Ibid

<sup>37</sup> See Research Report section 7.4

<sup>38</sup> Heritage Foundation, 2011, Build back safer with vernacular methodologies: DRR-driven post-flood rehabilitation in Sindh

<sup>39</sup> See Research Report section 7.4

**KEY RECOMMENDATIONS:  
PROTECTION, HEALTH & SAFETY**

1. Ensure doors are secure and lockable; and windows are operable and lockable (e.g. timber shutters) or inherently secure (e.g. 'hit and miss' brickwork)
2. Avoid indoor fires in order to reduce fire risk maintain air quality
3. Include insect mesh on doors, windows and any clerestory gaps

## Health and Safety

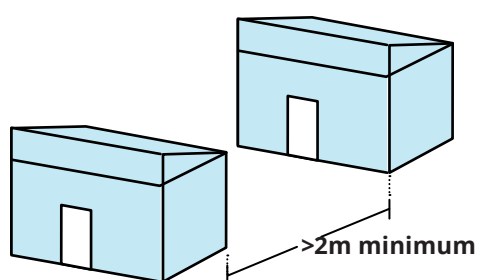

Figure 21. Distance between shelters for fire safety

### Fire Hazards

The shelters should pose a limited fire risk to inhabitants or neighbours. The use of indoor fires are an obvious concern and, as noted above, this guide recommends that fires should only be outdoors. Assuming that open flame sources are only found outdoors, the recommended designs exhibit limited fire risk. Most of the materials are non-combustible, with the exception of timber and bamboo roof materials, and loh kat which may pose a risk – particularly if the earth render has degraded and the wooden sub structure is exposed. The spread of fire between units is also understood to be low given low density of settlement and distance between shelters. In order to maintain this safety factor, this guide recommends shelters should not be built in close proximity of each other to reduce fire risk. The Sphere guidance of two metres between units should be considered as an absolute minimum.

### Vector Control

Shelters should protect inhabitants from vector borne risk by reducing exposure to, principally mosquitoes. This guide does not address water borne disease as that is outside the control of shelter design. However, unfortunately the data are inconclusive as to whether existing shelters increase, decrease or have no effect on malaria or dengue fever<sup>39</sup>. Geographical mapping of vector risk areas would need to be correlated with shelter and any clear-story gaps at ceiling level would help to decrease exposure. However, insect mesh would need to be diligently maintained in order to be effective.



# Sustainable

## Cost

BUDGET RANGE (USD)	FOUNDATION	WALL	ROOF
<\$400	Loh kat (basic), Stabilised Adobe	Loh kat, Stabilised Layered mud + Adobe	Bamboo, Timber, Steel
\$400 - 700	Loh kat (improved), Burnt brick	Loh kat, Stabilised Layered mud + Adobe	Bamboo, Timber, Steel
\$700 - 1,000	Burnt brick, Concrete	Burnt brick, Concrete block	Bamboo, Timber, Steel

Figure 22. Capital construction costs for component and material types

### Construction Cost

Shelters should be affordable for government agencies, implementing agencies and households themselves. The significant expansion of coverage achieved by Shelter Cluster was predicated on individual shelters costing approximately US\$500<sup>40</sup>. This guide has adopted a similar threshold but acknowledges that several designs exceed this range. Materials are a fairly fixed cost which typically require 70-90% of the construction budget. Construction costs also vary by component, i.e. foundations, walls, and roof types, with average breakdowns of 15% for foundations, 55% for walls and 39% for roofs (see chapter four). Therefore, material choice will largely be informed by cost.

Labour costs may vary and typically range from 10-30% of the construction budget<sup>41</sup>. Unskilled labour could be provided by the household or family and this could reduce costs somewhat. Similarly, if friends or family can provide skilled labour this may also reduce costs. Training is another way to offset construction labour costs and potentially provide livelihood opportunities though the measured impact of training on livelihoods currently underwhelming. However, the costs indicated in this guide assume that all labour is paid.

This guide recommends a hierarchy of material and component types based on cost (see Figure 22).

### Life Cycle Cost

The life cycle costs of a shelter should be considered at the design stage and the decision making process should include the individual household or village level considerations. Depending on circumstances, the preference may be for the lowest capital cost shelter with a short life span or a higher cost shelter with a longer life span. Our analysis does not reveal an optimum solution which is the lowest cost shelter with low maintenance costs that is longer lasting<sup>42</sup>. However, regular maintenance can greatly extend the life span of the shelter.

Based on the surveys, our analysis and judgement this guide sets a minimum life expectancy for all designs of 5 years and a preferred life expectancy of 15-30 years which only some of the designs may achieve. Our projections assume that once this life expectancy has been reached, the shelter will need to be completely rebuilt and the capital cost of construction reoccurs.

Operational and maintenance costs are considered in two ways: frequency and unit cost. In general, the more robust materials (e.g. concrete and fired brick) require less frequent maintenance. Whereas, loh kat requires regular maintenance once or twice a year. Repairs in response to specific events (e.g. flooding) are additional to these maintenance requirements. However, due to the high cost of concrete, fired brick and associated skilled labour the cost of maintenance for concrete and fired brick is disproportionately high relative to the cost of maintaining loh kat<sup>43</sup>.

**KEY RECOMMENDATIONS: COST**

1. Select the material and component types based on the available budget which ranges from approximately \$400 - \$1,000 (USD)
2. Consider the life cycle costs during the design decision process as some materials (e.g. burnt brick) have high capital but relatively consistent life cycle costs. Whereas other materials (e.g. loh kat) may have low capital but higher life cycle costs

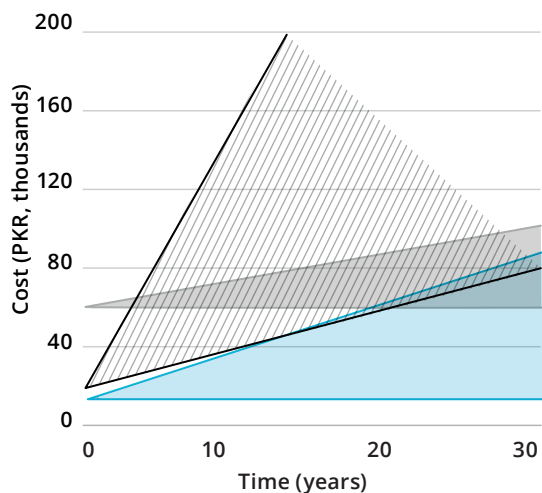

Cost at 0 years = capital cost of construction

- Lime Stabilised Adobe / Layered Mud
- Burnt Brick / Concrete
- Loh Kat

Figure 23. Life cycle costs for walls and foundations

The comparative life cycle cost ranges are graphed above and more information is available in chapter four. Foundations and walls have considerably more influence on life cycle costs relative to roofs.

This guide does not make a specific recommendation on which design to choose from a life cycle cost perspective as that depends on user preference. Instead we present a summary of the data to inform the decision making process:

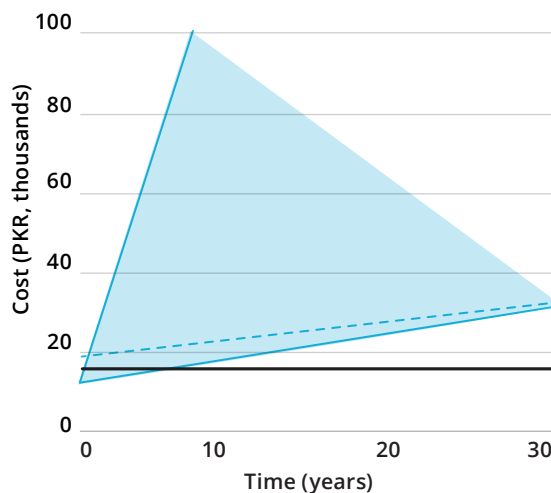

Cost at 0 years = capital cost of construction

- Bamboo / Timber (untreated)
- Bamboo / Timber (treated)
- Steel

Figure 24. Life cycle cost for roof structure

1. Lowest life cycle cost could be layered mud and adobe if both are well built, maintained and avoid excessive flooding. However, layered mud could prove quite expensive if there is an ongoing need to replace walls. Steel is generally the roof type with the lowest life cycle cost.
2. Mid range life cycle cost is for burnt brick or concrete walls and foundations which have relatively high capital costs but comparatively lower maintenance costs over 30 years. Well maintained bamboo or timber roofs could also be mid range.
3. Highest life cycle cost is most likely for loh kat walls and foundations given their comparatively shorter design life, need for frequent repair, and risk of insect attack. Timber and bamboo roofs may also have the highest life cycle cost if they are inadequately maintained or repeatedly attacked by insects.

<sup>40</sup> Shelter Centre, 2014, Evaluation of the ORS Program

<sup>41</sup> See Research Report section 8.1

<sup>42</sup> Ibid

<sup>43</sup> Ibid



## Local Supply Chain

### Availability of Materials

The materials required for construction should be locally available. While availability and cost may change, the surveys reported that 70-80% of all materials were “easy to obtain” which indicates that markets are working, supply is responding to demand, and hypothetically that demand may adjust in response to supply. The most challenging materials to procure were concrete blocks, bamboo, steel, window and doors. Procurement is restricted due to distance and the potential need for motorised transport. However, all existing materials are reportedly available within 15km of the site which is considered acceptable<sup>44</sup>. Therefore, this guide does not restrict or omit any of the existing materials from our recommended designs.

### Labour Standards

Shelter programming must ensure that human rights are respected, harm to people is avoided and efforts are made to maximise the positive contribution of the project ensuring that human rights are met throughout the supply chain. Our surveys indicate that 91% of homeowners were involved in the entire construction process and people are more inclined to want to be more involved rather than less involved in the future<sup>45</sup>. However, it should be noted that Shelter Centre’s evaluation indicates that the process of homeowner involvement reinforced women’s traditional role as builders and forced them to work harder rather than dividing the work with men<sup>46</sup>. In terms of child labour which is traditionally associated with burnt brick production, shelter agencies reported implementing child labour policies and monitoring systems<sup>47</sup>. Whilst their effectiveness is unknown some agencies reported avoiding fired bricks altogether.

The volume of reported injuries on site is comparable to the UK construction sector and within acceptable limits<sup>48</sup>. However, it can be assumed that the number of actual injuries exceeds the number of reported injuries.

.....  
<sup>44</sup> See Research Report section 8.2

<sup>45</sup> See Research Report section 6.4

<sup>46</sup> Shelter Centre, 2014, Evaluation of the ORS Program

<sup>47</sup> See Research Report section 8.2

<sup>48</sup> HSE: [hse.gov.uk/statistics/industry/construction](https://www.hse.gov.uk/statistics/industry/construction)  
.....

## Natural Resources

### KEY RECOMMENDATIONS:

#### LOCAL SUPPLY CHAIN & NATURAL RESOURCES

1. Utilise local materials wherever possible
2. Enforce labour policies (e.g. child labour in burnt brick production); consider women's traditional role in construction and how this can be shared (e.g. accommodate harvest season in scheduling); and record injuries on site
3. Pro-actively consider the handling and disposal of toxic materials (e.g. lime)
4. Prioritise renewable materials and those with low life cycle embodied energy (e.g. layered mud and adobe); and research alternative burnt brick production

In terms of recommendations, this guide suggests:

1. Future implementation should be aware of the harvest season and enable women, in particular, to adjust the timelines of construction to their existing commitments.
2. Child labour policies have been developed by shelter agencies but it should be acknowledged that it will be difficult or impossible to monitor all aspects of the supply chain. These policies need not extend to children helping their families during construction.
3. Injuries should be monitored and recorded to understand what the injuries are, their severity and what caused them. In particular, as power tools or more complex construction methods are adopted, injuries may become more severe.

### Recycled / Reused

Materials should be reused or recycled as much as possible in the context of a resource scarce environment. Our surveys indicate that materials are extensively reused and recycled. There were only five instances reported from 800 surveys of materials being unused following construction which indicates that materials are reused/recycled by necessity. In particular, windows and doors are frequently reused<sup>49</sup>. Therefore, it appears unnecessary at this time to make recommendations about the reuse or recycling of materials as it is already being carried out by default. However, there are some concerns about the disposal and handling of certain toxic materials, e.g. diesel, sump oil and red red oxide paint<sup>50</sup>. Their use should be avoided, especially given that they are ineffective in their main use of protecting timber/bamboo. Whilst lime is not toxic to soil and water it can burn skin and its use should be controlled at a community level to ensure adequate storage and handling. Shelter Centre indicate that this is already happening given the efficiencies of scale in the production process<sup>51</sup>.

<sup>49</sup> See Research Report section 8.3

<sup>50</sup> Ibid

<sup>51</sup> S Shelter Centre, 2014, Evaluation of the ORS Program

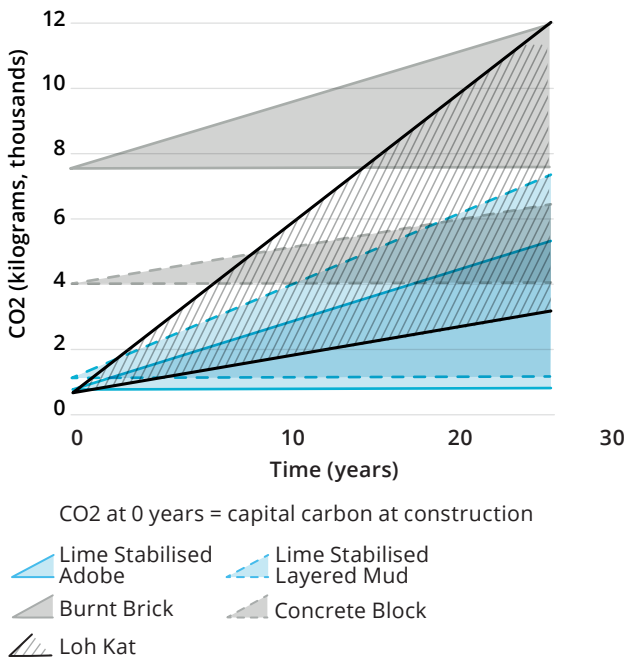
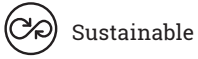

Figure 25. Life cycle embodied energy for walls and foundations

**Embodied Energy**

The embodied energy and carbon emissions associated with construction must be reduced globally. Though Pakistan is ranked 155th in terms of carbon dioxide emissions per capita<sup>52</sup>, an opportunity exists to avoid energy intensive development trajectories. Based on our analysis, the walls of a shelter are the largest contributor to overall carbon dioxide per square metre. The embedded carbon dioxide in initial construction of shelters ranges from 50 – 350 kg/m<sup>2</sup> with adobe and potentially layered mud at the low end, and burnt brick or loh kat or layered mud at the high end.

However, the life cycle range for loh kat and layered mud is very broad and this depends on how frequently the walls need to be replaced based on the quality of initial construction and ongoing maintenance. Our calculations do not account for sequestered carbon associated with lime, bamboo and timber which may have an impact life cycle carbon analysis.

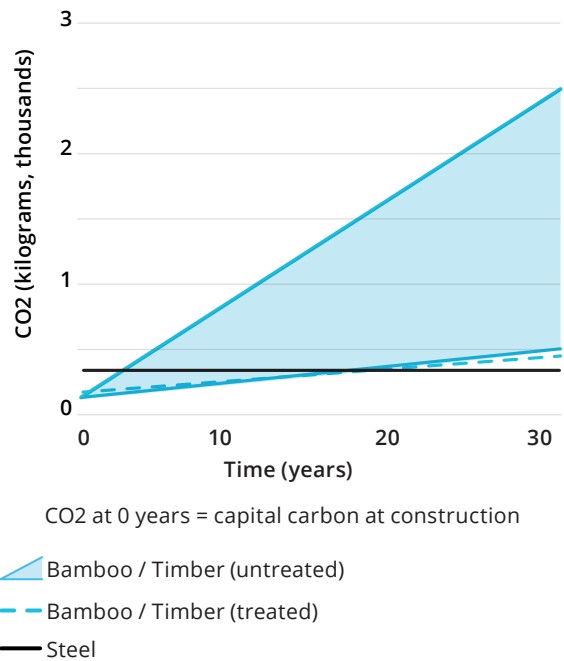

Figure 26. Life cycle embodied energy for roofs

The carbon footprint for burnt brick shelters is a concern and can be compared to benchmarks developed by Arup for steel and concrete buildings in the UK. However, given the comparatively longer life span of UK buildings, the Pakistan shelters should be considerably lower than this UK benchmark. This guide recommends that renewable resources (e.g. adobe, mud, bamboo) be prioritised for shelter design and alternative fired brick production be researched in an effort to reduce the carbon footprint for this material.

<sup>52</sup>See World Bank: <https://data.worldbank.org/indicator/EN.ATM.CO2E.PC?end=2014&locations=PK&start=1960&view=chart>

# 02

---

# Design Decision Tool

---

This chapter contains the design decision tool which enables the user to make informed decisions about the most appropriate design options provided in chapter three. The process is intended to enhance the existing approach for shelter design decisions. Questions are presented in order to align user preferences with the evidence and analysis. The user is guided through the selection of wall, roof, and foundation typologies. This outline design is evaluated against the key performance criteria which are 'Safe and Resilient', 'Acceptable', and 'Sustainable'. Detailed design options are discussed in order to identify what options or additional design measures the user may want to include.

# How to Use the Design Decision Tool

The design decision tool is organised in three stages: outline design, evaluation and detailed design. The notes sheet (see chapter four) can be used throughout to record answers and notes. This sheet functions as a record of these decisions and identifies what design information is required from chapter three.

There are 13 components to choose from (five wall types, three roof types and five foundation types). The compatibility of these components results in a total of 26 potential outline designs. Three pages guide the user through the selection of the wall, roof and foundation which constitutes their outline design. The questions align user preferences with the appropriate component. The questions were designed in consultation with end users and are based on actual questions used in the design of previous shelter programmes in Sindh.

The design decision tool begins with 'what wall should I use?'. However, it is possible to use the design decision tool in other ways and start with foundations or roofs as desired. Consultation with end users identified the wall type as the primary driver of component selection, i.e. people think about the wall first, then decide what roof and foundation to use.

Having selected the wall, roof and foundation types the user may have several potential outline designs. The guide recommends that a maximum of 2-3 outline designs be evaluated. The user can revisit their answers in order to refine or limit the number component types. We recommend that this should be based on user prioritisation of budget, material availability or user preferences.

The evaluation graph on page 34 allows the user to identify which of their outline designs performs best. Ultimately, this evaluation is subjective as the relative importance of 'Safe and Resilient', 'Acceptable', and 'Sustainable' will vary according to the priorities of the user.

Finally, there are various detailed design variations which are required or optional and these are discussed on page 36.

The user can record their chosen outline design and detailed design variation on the notes sheet and extract the relevant pages from the design information in chapter three.

# What wall should I use?

Answer the questions below and use the decision tree to identify the most appropriate wall type. If more than two wall types are selected, try to prioritise your answers based on what is most important to you: the overall construction budget, availability of materials, user preferences or permanence. Record your preferred wall type(s) on the notes sheet.

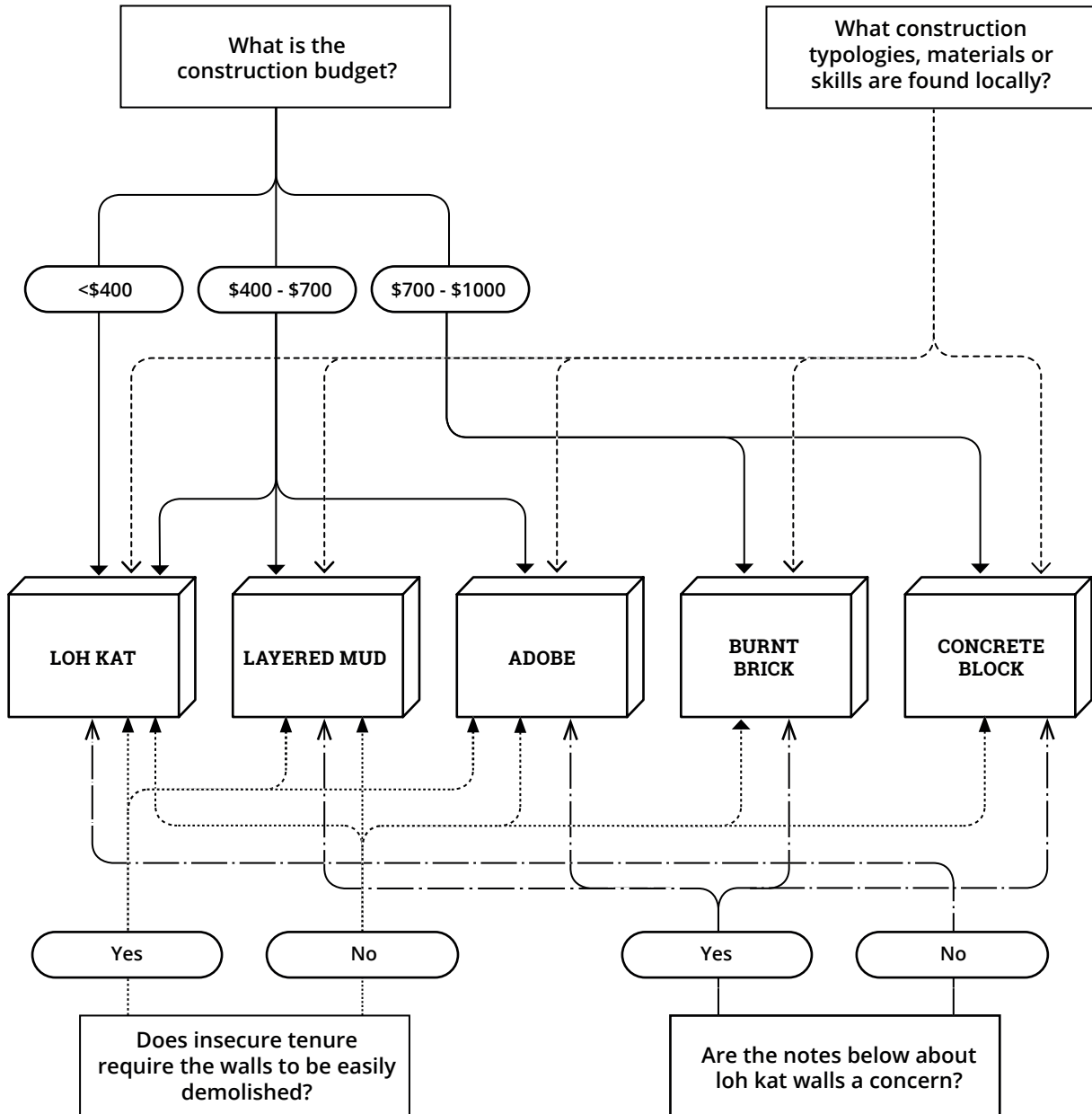

**Notes**

Loh kat walls slightly under perform relative to other wall typologies in relation to thermal comfort. Their reduced thickness provides less thermal mass to absorb heat from the sun.

Loh kat walls are generally perceived as being less secure than there wall typologies as they are easier to break into. If built in accordance with the design information, loh kat walls can be physically secure but this may not change their perception of safety.

# What roof should I use?

Answer the questions below and use the decision tree to identify the most appropriate foundation type. If more than two foundation types are selected, try to prioritise your answers based on what is most important to you: the overall construction budget, availability of materials, or ease of demolition. Record your preferred foundation type(s) on the notes sheet and quickly check if they are compatible with your preferred wall types.

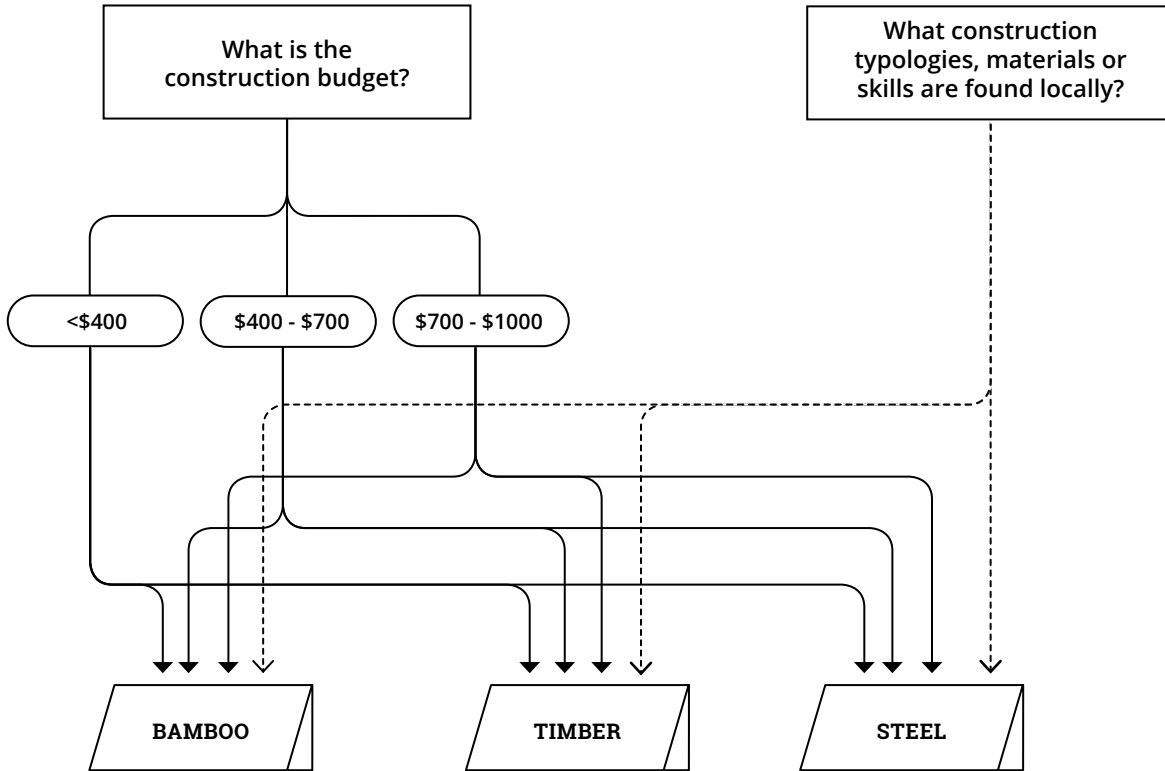

# What foundations should I use?

Answer the questions below and use the decision tree to identify the most appropriate foundation type. If more than two foundation types are selected, try to prioritise your answers based on what is most important to you: the overall construction budget, availability of materials, or ease of demolition. Record your preferred foundation type(s) on the notes sheet and quickly check if they are compatible with your preferred wall types.

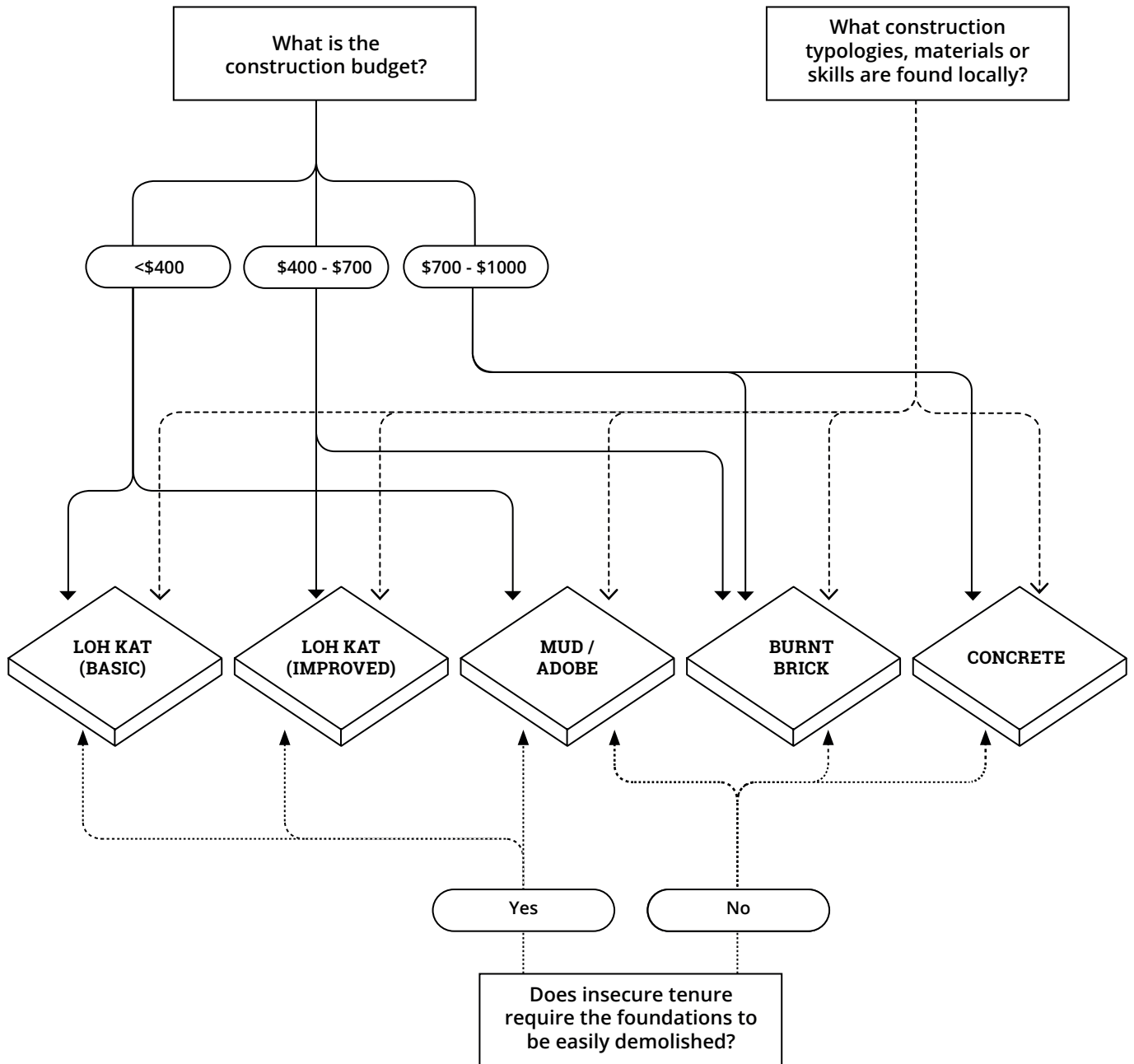

# Outline Design Evaluation

This graph presents the evaluation of all 26 outline designs against the key performance criteria which are 'Safe and Resilient', 'Acceptable', and 'Sustainable'. While all the recommended designs conform to improved resilient standards, there are differences in performance based on our analysis and testing. The primary differences are in 'Safe and Resilient' and 'Sustainable'. Most designs perform consistently well in 'Acceptable'. For example, burnt brick and concrete are very safe and resilient but relatively unsustainable due to their cost. In contrast, loh kat and layered mud are very sustainable but relatively less safe and resilient due to the fragility of their material characteristics.

The user can identify which of their outline designs performs best. Ultimately, this evaluation is subjective as the relative importance of 'Safe and Resilient', 'Acceptable', and 'Sustainable' will vary on a case by case basis.

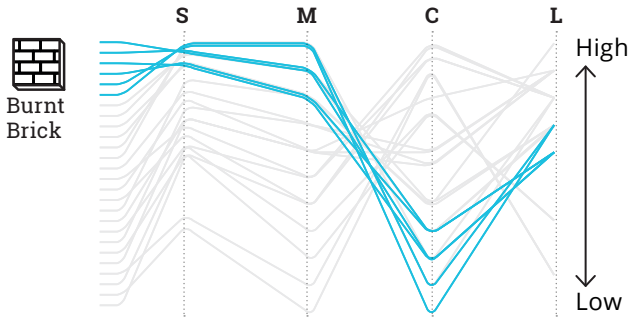

Burnt brick performs well in structural and water resilience and maintenance but poorly in capital cost and carbon

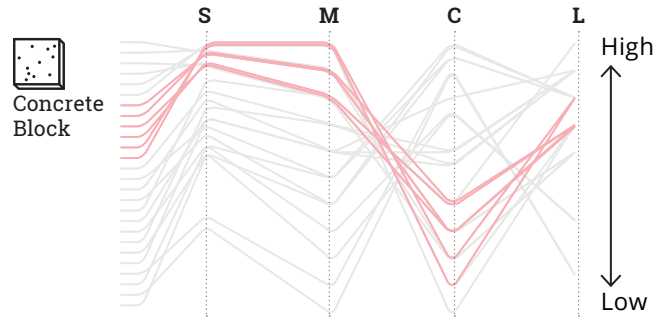

Concrete block performs similarly to burnt brick

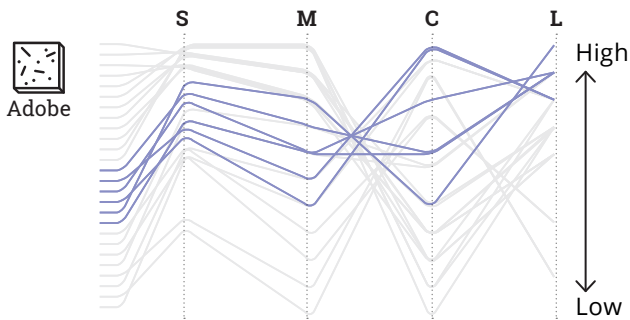

Stabilised adobe blocks perform relatively well across all categories, particularly in lift cycle cost

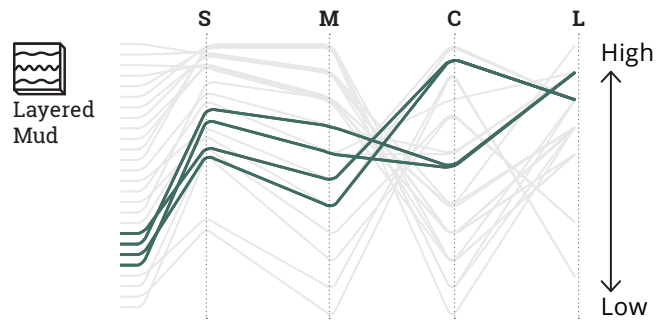

Stabilised layered mud has a similar performance to adobe in cost and carbon and life cycle. However layered mud performs less well for structure and maintenance.

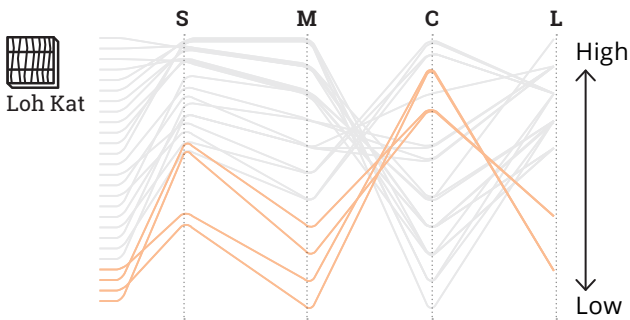

Loh kat performs well for initial cost, but poorly for structure, maintenance and life cycle, due to the possibility of rot and insect attack of members. It should be noted that the structural score does not consider seismic performance.

- Key
- S** Structural and water resilience
  - M** Maintenance
  - C** Capital cost and carbon
  - L** Life cycle cost and carbon

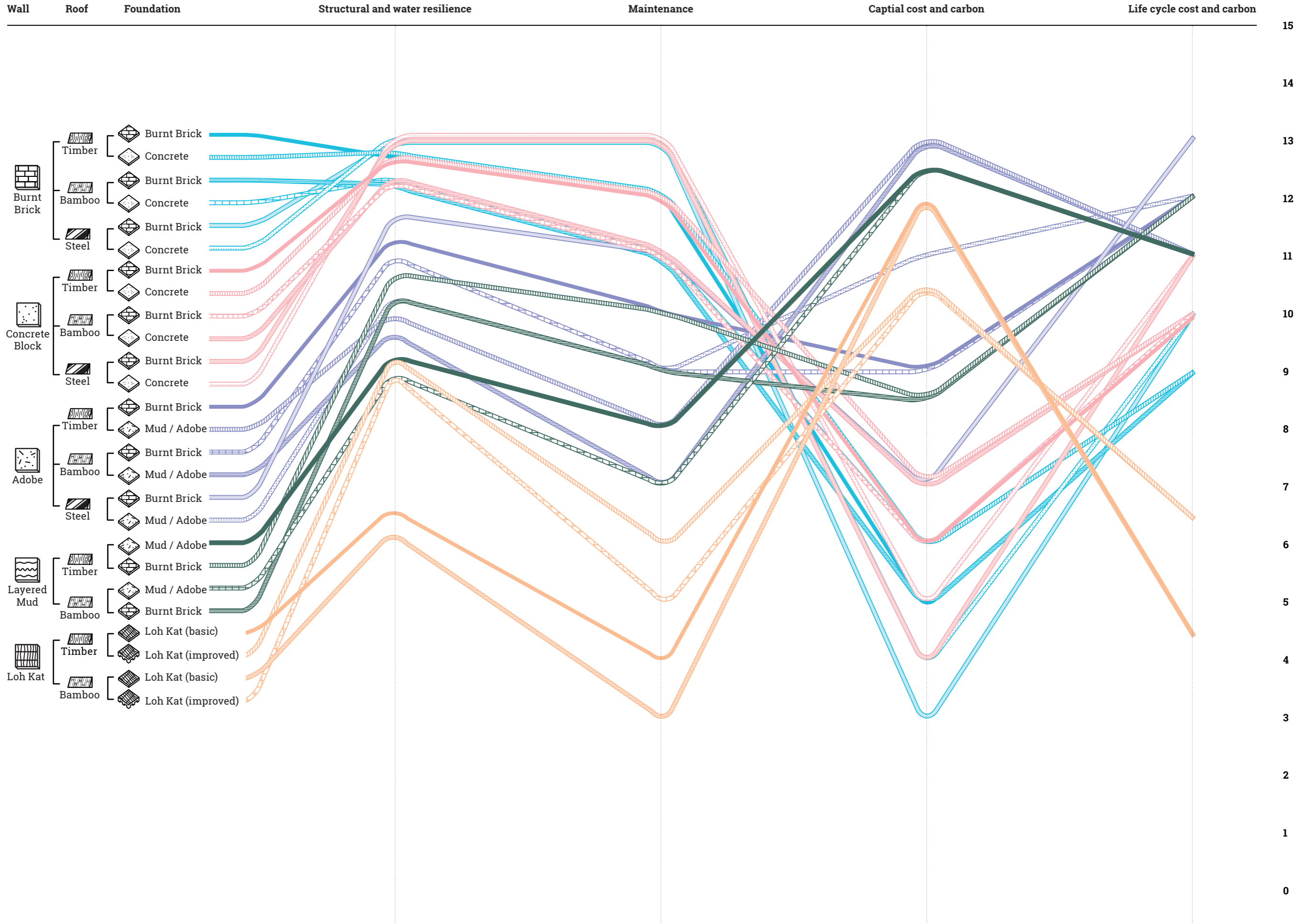

# Detailed design variations

By this stage the user should have selected their preferred outline design and can now choose from a range of detailed design variations. Some elements are compulsory (e.g. ring beams, windows and doors) though there are variations which respond to cost and user preference. Other elements are optional (e.g. raised platforms) but recommended by this guide. Design information for all detailed design variations are included in chapter three. These variations and their characteristics are:

RING BEAM TYPE	COMPATIBLE WALL TYPE	COMPATIBLE ROOF TYPE
Reinforced Concrete	Burnt Brick, Concrete Block, Adobe	Bamboo, Timber, Steel
Timber	Burnt Brick, Concrete Block, Adobe, Layered Mud	Bamboo, Timber
Bamboo	Burnt Brick, Concrete Block, Adobe, Layered Mud	Bamboo

Figure 27. Ring beam compatibility

## Ring beams

Ring beams are required for all designs except for loh kat which is a framed structure and doesn't require a separate ring beam. The ring beam options are reinforced concrete, timber or bamboo. Each one has slightly different characteristics which impact their cost, build ability and compatibility with different wall types. These parameters are described in figure 27 above. This guide makes specific recommendations which are explained in the design information.

## Raised Platform and/or Plinth

Raised platforms and/or plinths are not required but are strongly recommended by this guide in order to maintain the functionality or use of the shelter during a flood. Platforms and plinths do not affect the structural performance of the shelter which requires water resistant treatment that is already included in the design information for walls and foundations. This guide makes specific recommendations which are included in the design information.

## Windows and Doors

Windows and doors are required for all designs. This guide recommends two window variations which are 'hit and miss' or a shuttered version. Both perform adequately in terms of light, ventilation and security. Hit and miss is secure by design and comparatively cheaper. The screened version requires a locking mechanism and we anticipate could be considerably more expensive. This guide makes specific recommendations which are included in the design information.

# 03

---

# Design Information

---

This chapter contains the complete one room shelter designs based on existing local practice and supplemented with the findings of this research project. This information is grouped by outline design components (five foundation types, five wall types, and three roof types) and detailed design variations (ring beams, windows and doors, platforms and plinths). For the interested user, further information is available in chapter four. Due to the relative simplicity of one room shelters, the information provided in this chapter should be sufficient to use for construction. The key design considerations, geometry, materials specification, and construction details are provided to support quality workmanship and assurance on site.

# How to read the design information chapter

◇ Component type - eg foundation, wall, roof

## Material - eg timber, bamboo

3D view

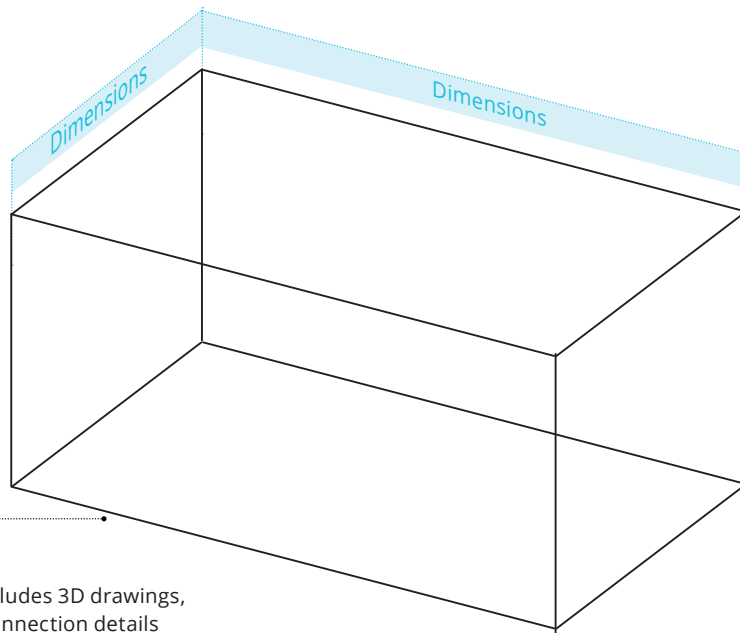

Each design includes 3D drawings, sections and connection details

Annotations are provided on the drawings to label the materials, explain the design features and advise on how to construct the shelter

3D details



3D details



### SEISMIC CONSIDERATION

South Pakistan is a region of moderate to high seismicity. Whilst seismic design outside of the scope of this guide these additional measures would serve to improve seismic performance of the shelter.



#### Performance variation

It may be desirable to change an aspect of the design. The impact on performance is highlighted here.



#### Maintenance

Maintenance considerations are highlighted here



#### Health and Safety

High level site health and safety considerations are provided here



#### Specification

Links to more detailed material specifications in chapter 4 supporting information are listed here



# Loh Kat (improved)

## 3D view

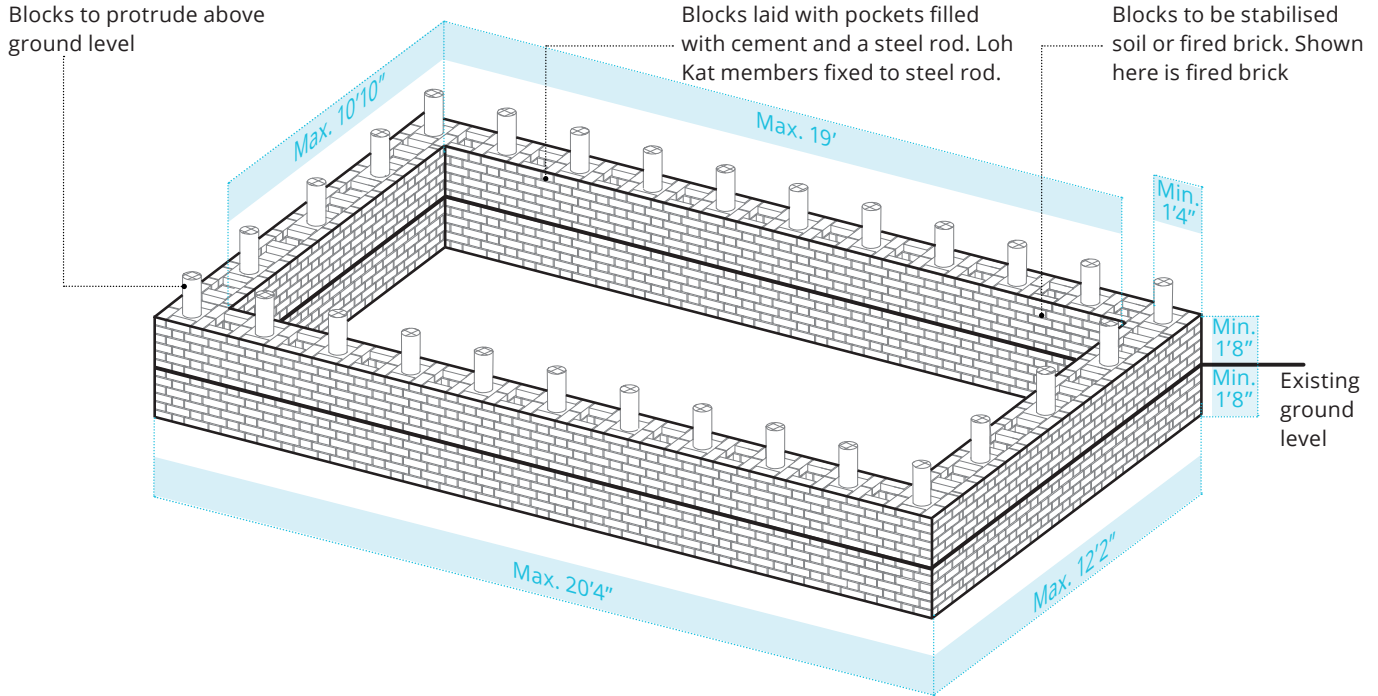

## 3D detail

1. Pockets filled with concrete with cast in steel rod.
2. Grout hole notched into bamboo
3. Bamboo placed over steel rod. Bamboo remains above the blocks, and is not cast into the concrete
4. Bolt, if available, fixed through bamboo and steel rod
5. Bamboo filled with grout

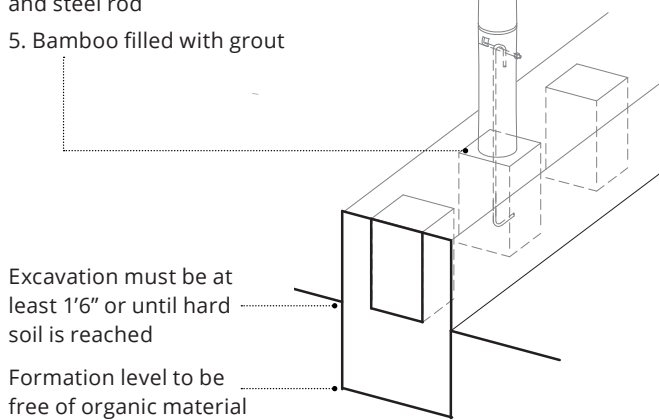

## 3D brick bond detail

Brick bond to allow pockets for filling with concrete and securing loh kat members

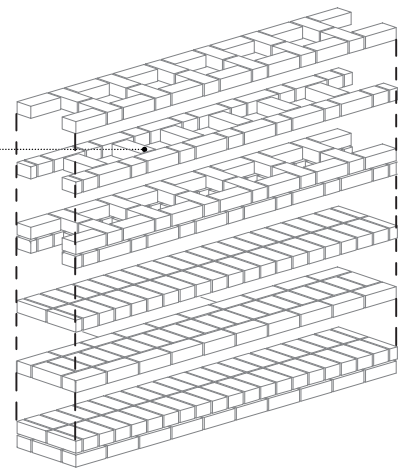

### SEISMIC CONSIDERATION

This foundation is recommended over the 'basic loh kat' foundation for improved seismic performance

**Variation**  
 Replacing stabilised blocks with burnt bricks will:  
 + Buildability  
 - Sustainability  
 - Cost

**Maintenance**  
 Ensure sloped drainage is maintained  
 Repair render on foundation walls  
 Repair bricks if damaged

**Health and Safety**  
 Lime/Cement used in stabilisation can burn skin. Wear gloves and boots.  
 Blocks are heavy, take care when lifting

**Specification**  
 Stabilised blocks/Burnt brick  
 Block laying  
 Concrete  
 Steel



Foundation

# Loh Kat (basic)

## 3D view

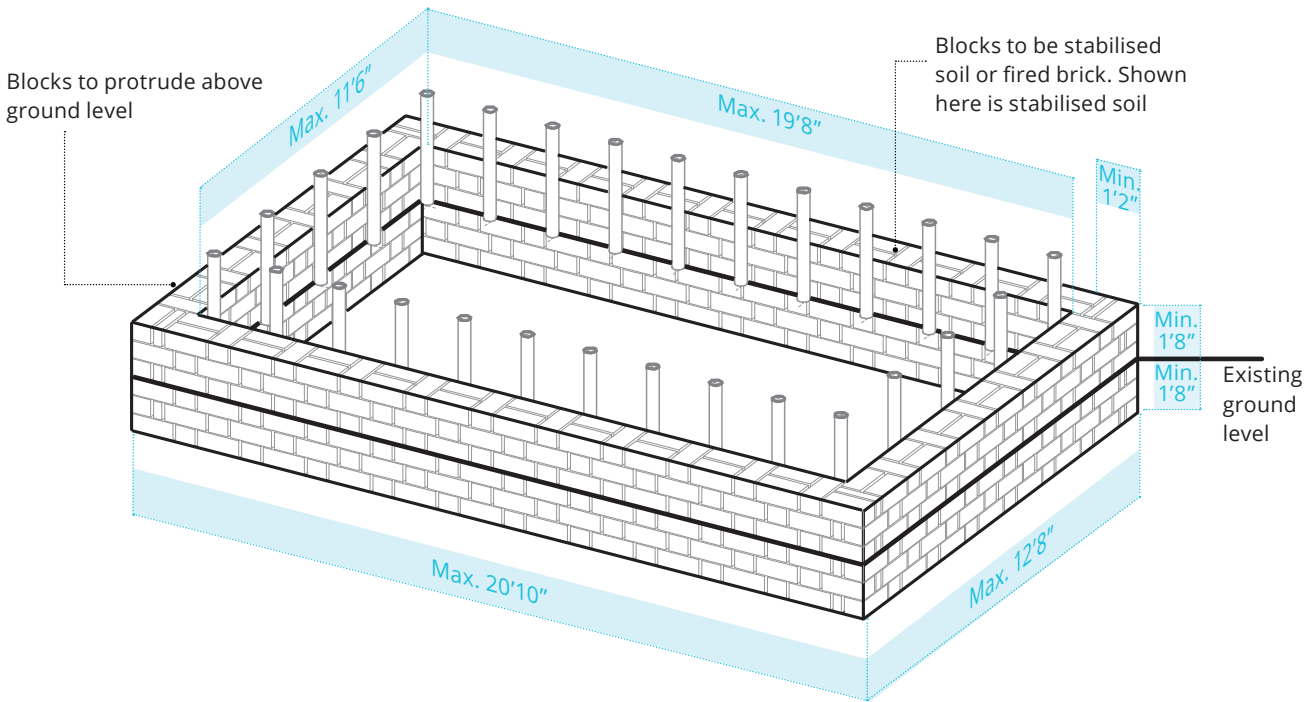

## 3D detail

Granular material surrounds bamboo/timber pocket, to allow water which reaches the bamboo to drain away

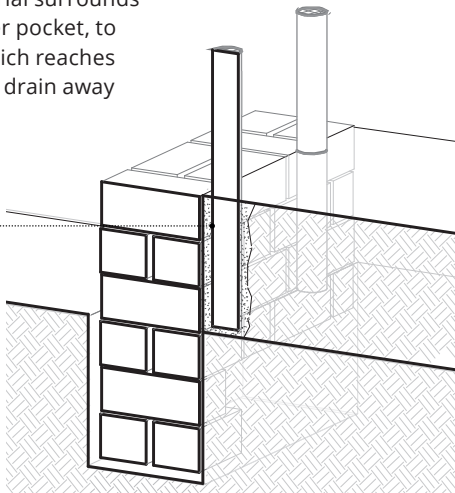

## 3D brick bond detail

Brick bonds alternate to ensure connections between courses and around corners

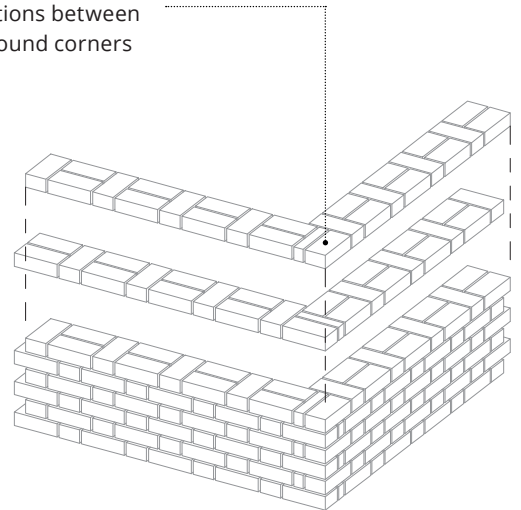

### Variation

Replacing stabilised blocks with burnt bricks will:  
 + Buildability  
 - Sustainability  
 - Cost



### Maintenance

Ensure sloped drainage is maintained  
 Repair render on foundation walls  
 Repair bricks if damaged



### Health and Safety

Lime/Cement used in stabilisation can burn skin. Wear gloves and boots.  
 Blocks are heavy, take care when lifting



### Specification

Stabilised blocks/Burnt brick  
 Block laying



# Stabilised layered Mud / Adobe blocks

3D view

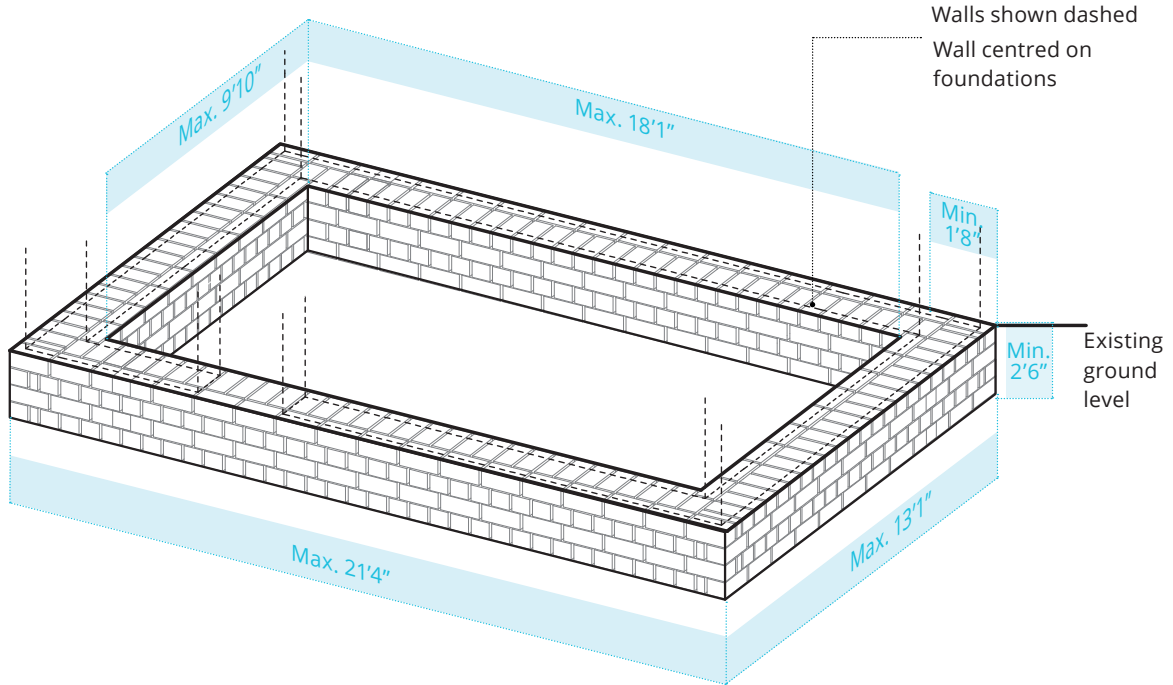

3D detail

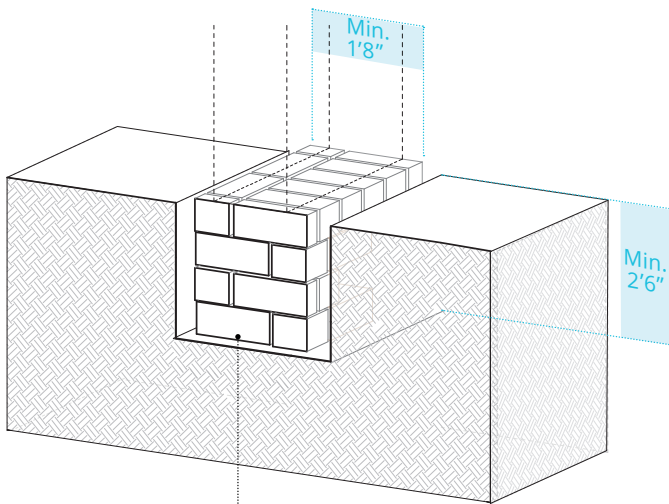

Excavation must be at least 2'6" or until hard soil is reached Formation level to be free of organic material

3D brick bond detail

Brick bonds alternate to ensure connections between courses and around corners

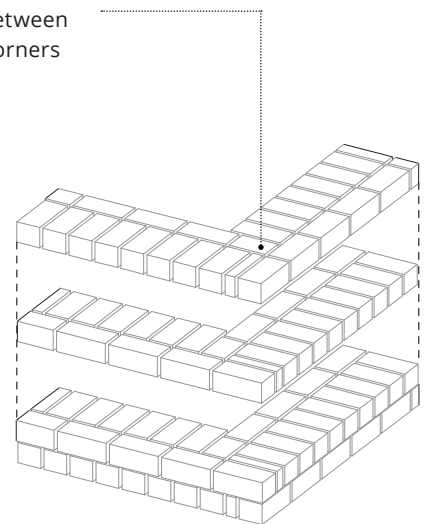

**Variation**  
Use of cement for stabilisation:  
+ Buildability  
- Sustainability  
- Cost

**Maintenance**  
Ensure sloped drainage is maintained  
Repair render on foundation walls  
Repair bricks if damaged

**Health and Safety**  
Lime/Cement used in stabilisation can burn skin. Wear gloves and boots.  
Blocks are heavy, take care when lifting

**Specification**  
Stabilised blocks/earth  
Block laying  
Damp proof membrane



# Burnt Brick

## 3D view

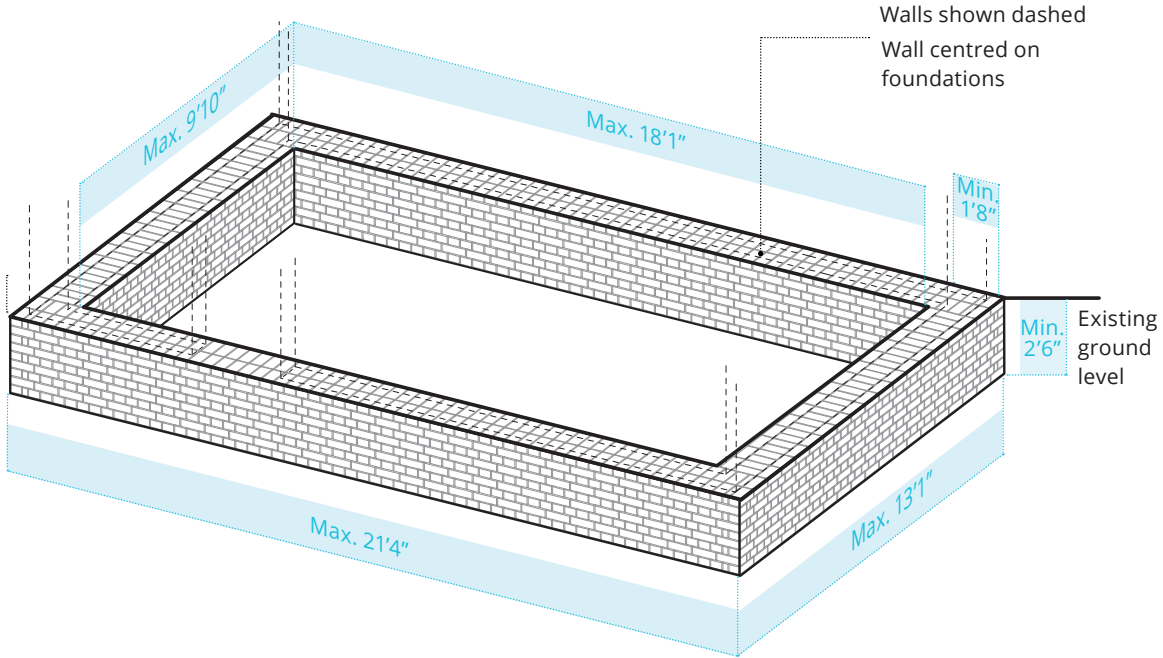

## 3D detail

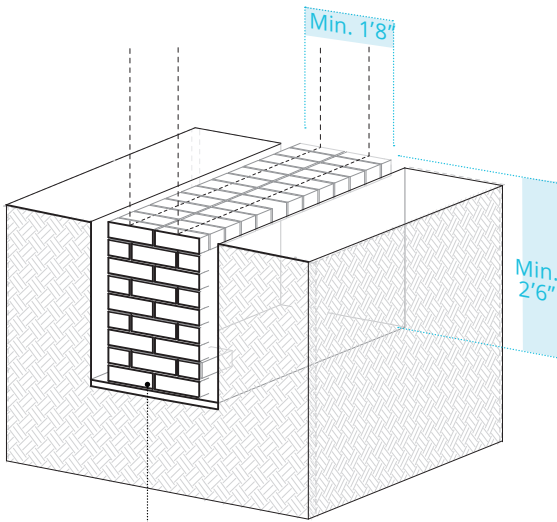

Excavation must be at least 2'6" or until hard soil is reached Formation level to be free of organic material

Concrete blinding at base of excavation

## 3D brick bond detail

Brick bonds alternate to ensure connections between courses and around corners

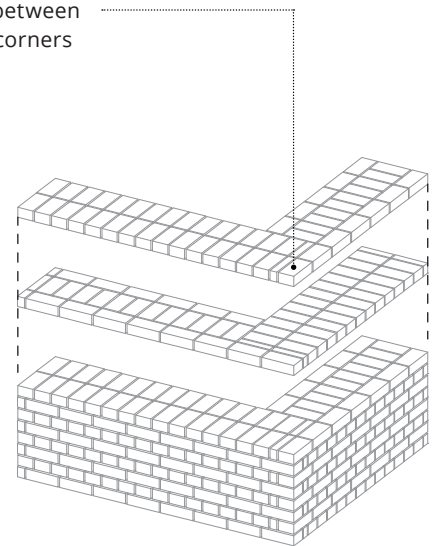

**Maintenance**  
 Ensure sloped drainage is maintained  
 Repair render on foundation walls  
 Repair bricks if damaged

**Health and Safety**  
 Lime/Cement used in mortar can burn skin. Wear gloves and boots.

**Specification**  
 Burnt brick  
 Block laying  
 Damp proof membrane



# Concrete block

## 3D view

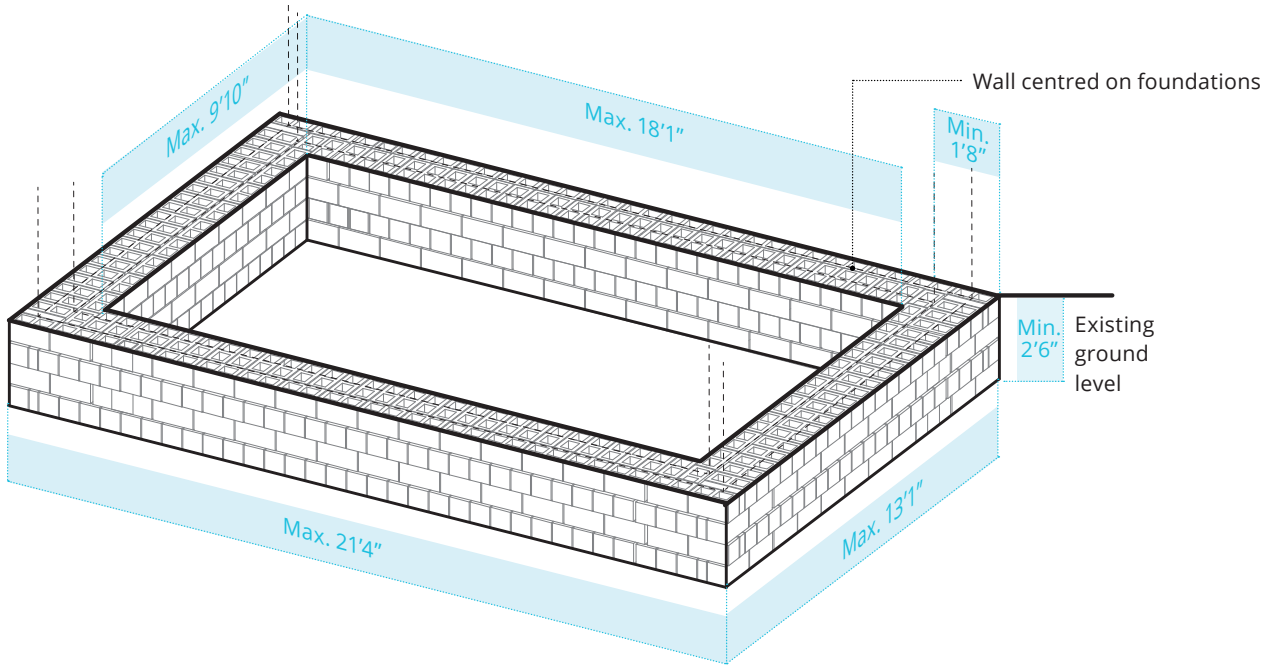

## Plan [Not to scale]

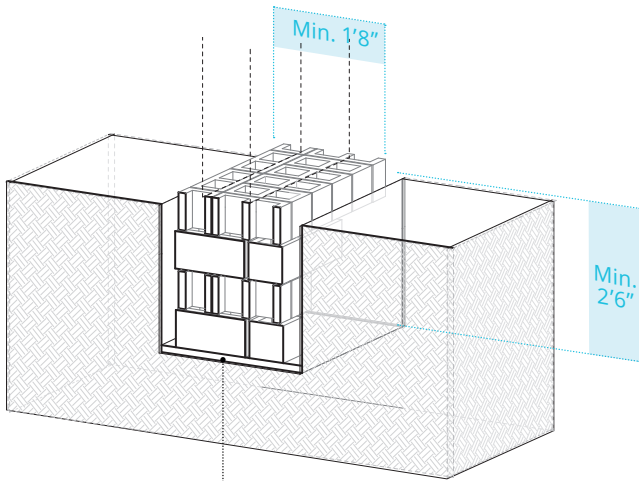

Excavation must be at least 2'6" or until hard soil is reached  
 Formation level to be free of organic material  
 Concrete blinding at base of excavation

## 3D brick bond detail

Brick bonds alternate to ensure connections between courses and around corners

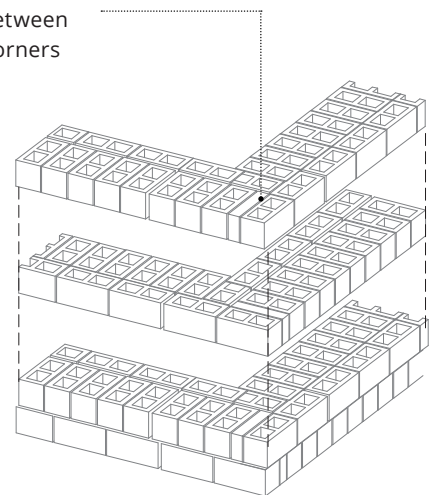

### SEISMIC CONSIDERATION

If walls are to be reinforced for improved seismic performance, it will need to be anchored into the foundations



**Maintenance**  
 Ensure sloped drainage is maintained  
 Repair render on foundation walls  
 Repair bricks if damaged



**Health and Safety**  
 Cement used in blocks and mortar can burn skin. Wear gloves and boots.



**Specification**  
 Concrete  
 Block laying  
 Damp proof membrane



Wall Component

# Loh Kat

3D view

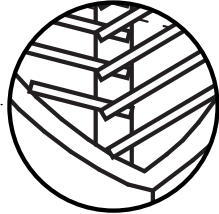
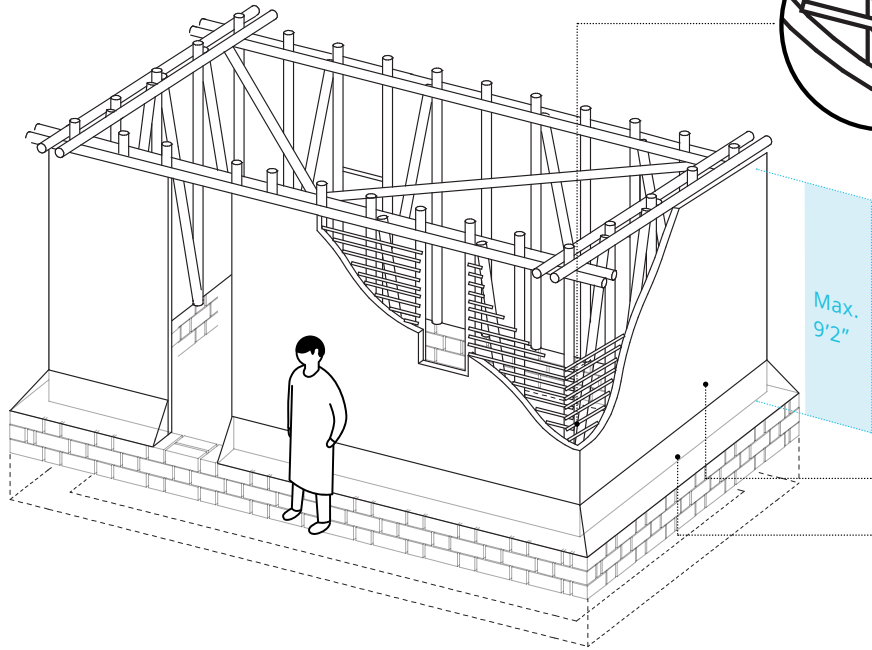

Horizontal members attached to main loh kat frame; split bamboo, cane, small diameter bamboo or timber are all fine. Chicks matting is not ok.

Stabilised render

Drainage slope, from stabilised render, at base of wall

Skeleton 3D view

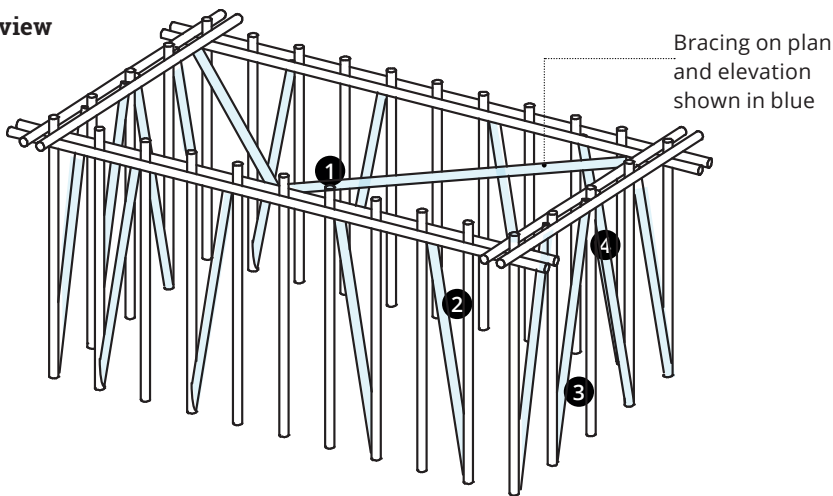

Bracing on plan and elevation shown in blue

Plan [Not to scale]

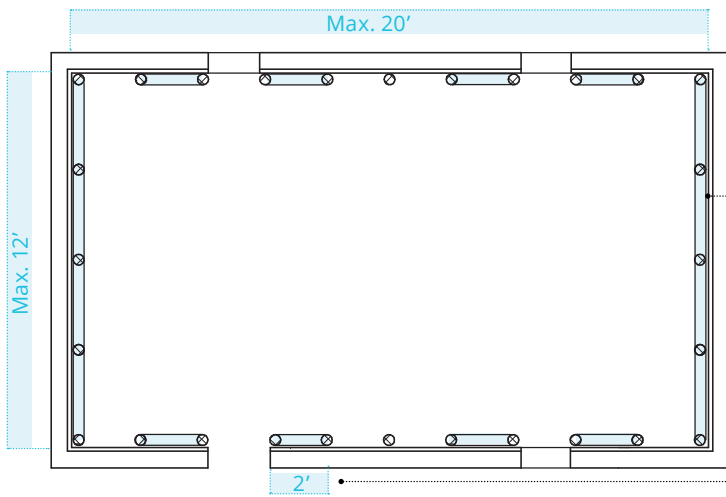

Bracing on elevation shown in blue

3' spacing of loh kat members on short walls

2' spacing of loh kat members on long walls

**3D details**

For all loh kat connections, extend bamboo to provide a 6" edge distance from the connection bolt hole to the end of the bamboo. Ensure there is at least one node in this 6" zone



For all loh kat connections, use 0.5" diameter bolts and pre-drilled holes, with 1" washers on both ends

Ensure connections stay dry and do not have any splits or fissures

**1 Roof plan bracing connection**

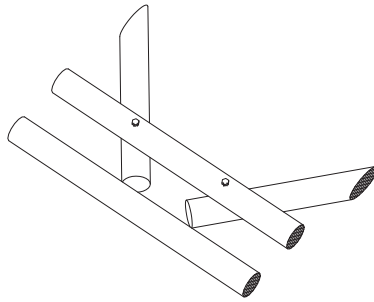

**2 Top corner connection**

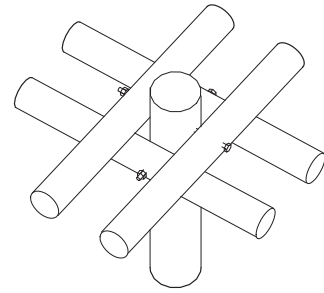

**3 Bottom bracing connection on elevation**

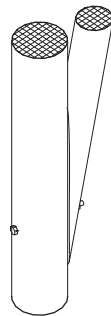

**4 Top bracing connection on elevation**

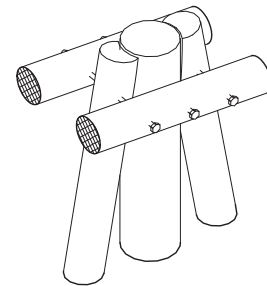

**Section [not to scale]**

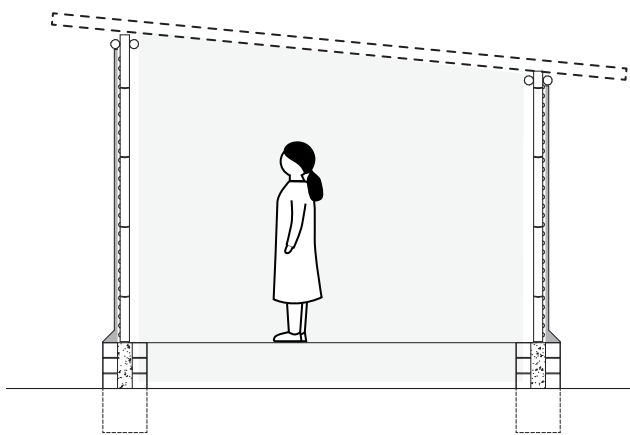

**Detail section [Not to scale]**

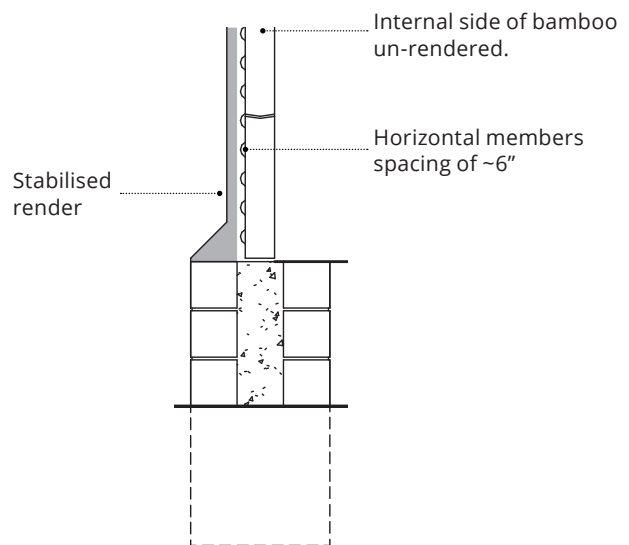

**SEISMIC CONSIDERATION**

Lightweight Loh Kat walls will perform well seismically and are preferred to other heavier options in this guide.  
- It is recommended to double the amount of roof braces



**Variation**

Replacing lime for cement for stabilisation of render:  
+ Buildability  
- Sustainability  
Replacing bamboo with timber  
+ Maintenance



**Maintenance**

Repair render.  
Avoid bamboo/timber getting wet.  
Remove termite tracks  
If bamboo/timber members deteriorate, replace.



**Health and Safety**

Lime/Cement used in render can burn skin. Wear gloves and boots.



**Specification**

Bamboo/timber  
Stabilised render



Wall Component

# Stabilised Layered Mud

## 3D view

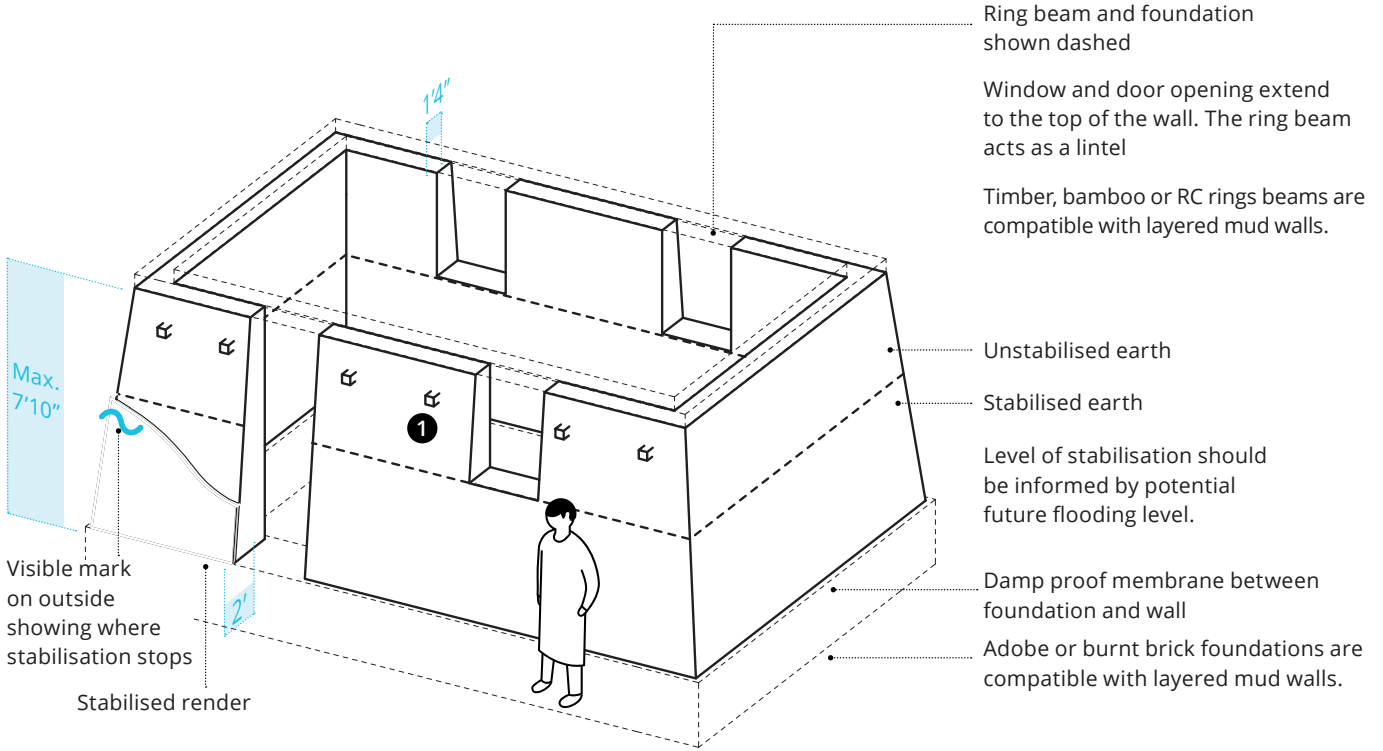

## Plan [Not to scale]

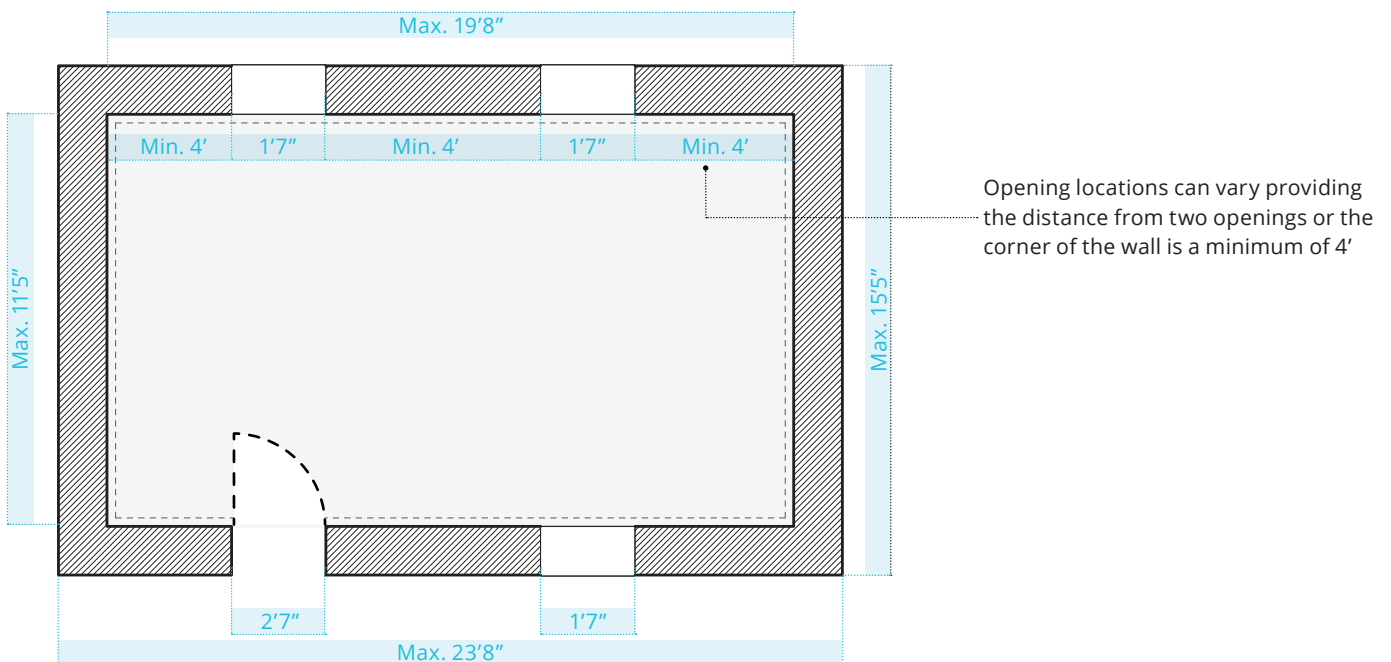

1

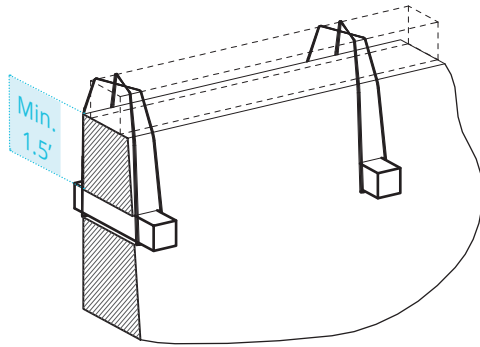

**A Tie Connection**  
A wooden peg is cast into the wall and wire used to secure the ring beam. This option is easier to build and appropriate for timber and bamboo ring beams.

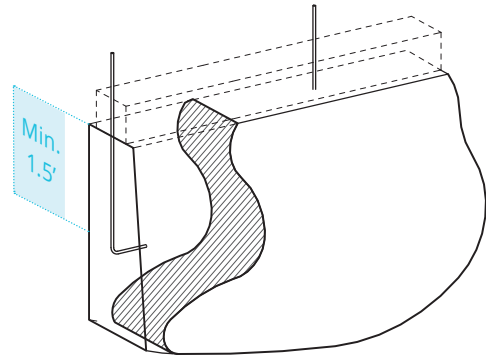

**B Bolt Connection**  
A steel rod is cast into the wall and a bolt is used to secure the ring beam. This option is appropriate for timber and RC ring beams.

**Section [not to scale]**

Wall is capped with a ring beam and approximately 1' of additional wall build up

Additional wall build up ~1'  
Ring beam

Layered mud walls are vertical on the inside face and taper externally

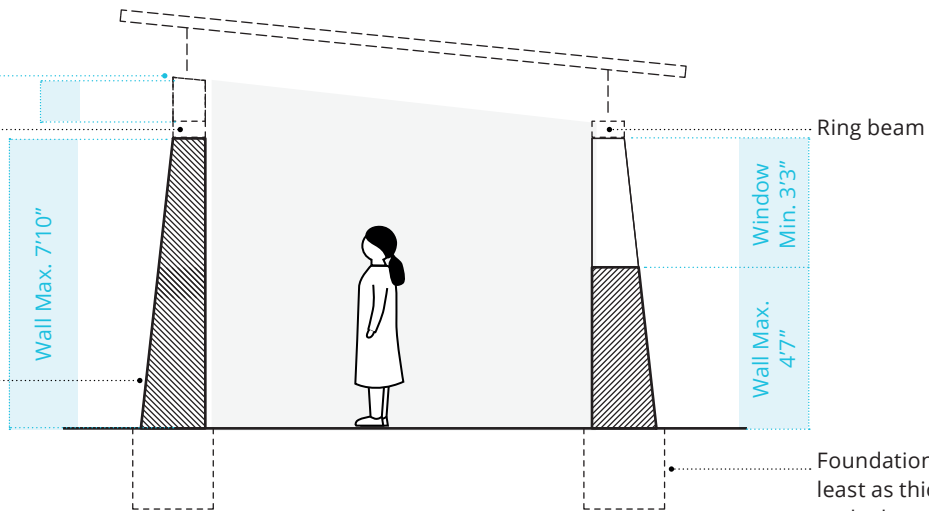

Foundations must be at least as thick as the walls at the base

**SEISMIC CONSIDERATION**

Layered mud walls are heavy and will perform poorly in an earthquake, therefore avoiding layered mud as a construction method is recommended, though a combination of the following measures will improve seismic performance:

- Use piers at the corners and in the middle of the long wall.
- Use the bolted connection.
- Use a seismically improved timber or bamboo ring beam (see Design Information, Ring Beam)



**Variation**  
Replacing lime with Cement for stabilisation:  
+ Buildability  
- Sustainability  
Replacing tie with bolt connection:  
+Stability  
-Buildability



**Maintenance**  
Repair render if damaged.  
Replace wire/rope in tied connection if damaged/rusted.



**Health and Safety**  
Lime/Cement used in stabilisation can burn skin. Wear gloves and boots.



**Specification**  
Stabilised earth  
Stabilised render



Wall Component

# Stabilised Adobe

## 3D view

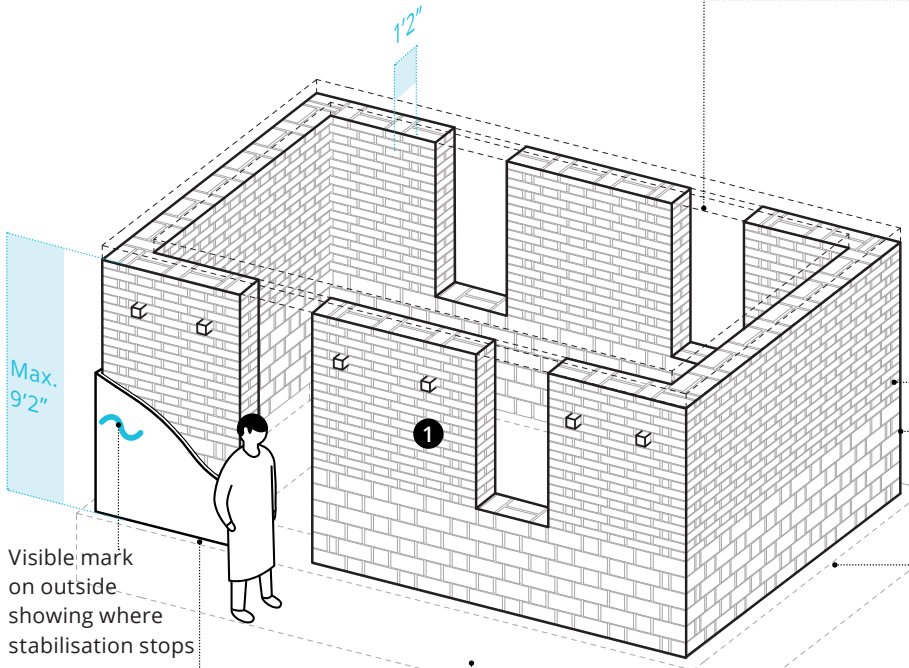

Ring beam and foundation shown dashed  
 Window and door opening extend to the top of the wall. The ring beam acts as a lintel  
 Timber, bamboo or RC rings beams are compatible with adobe walls

Stabilised and unstabilised blocks differ in size  
 Unstabilised earth  
 Stabilised earth  
 Level of stabilisation should be informed by potential future flooding level.

Damp proof membrane between foundation and wall

Max. 9'2"

Visible mark on outside showing where stabilisation stops

Stabilised render

Adobe or burnt brick foundations are compatible with adobe walls.

### Brick bond corner detail

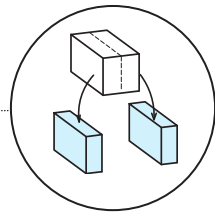
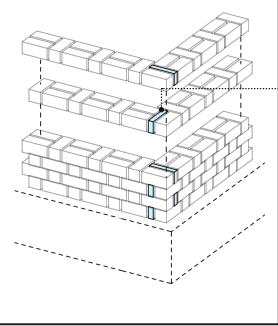

Brick bonds and half bricks must alternate as indicated in order to connect the four walls together. Half bricks are also required at openings.

## Plan [Not to scale]

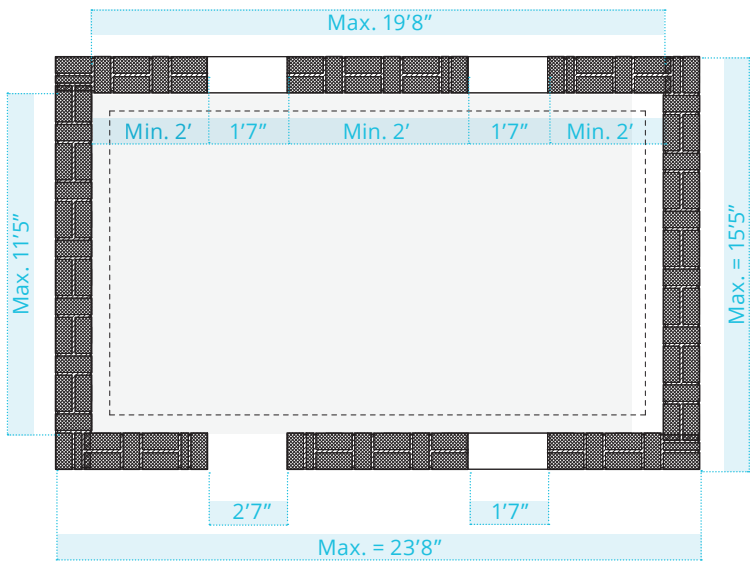

1

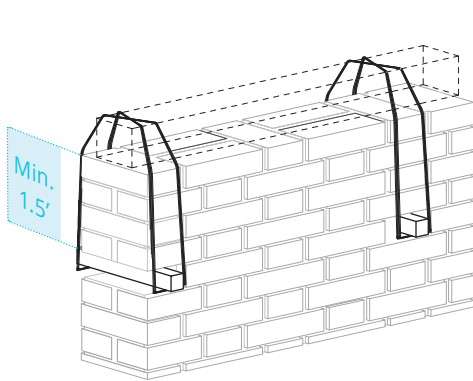

**A Tie Connection:** A wooden peg is cast into the wall and wire used to secure the ring beam. This option is easier to build and appropriate for timber and bamboo ring beams.

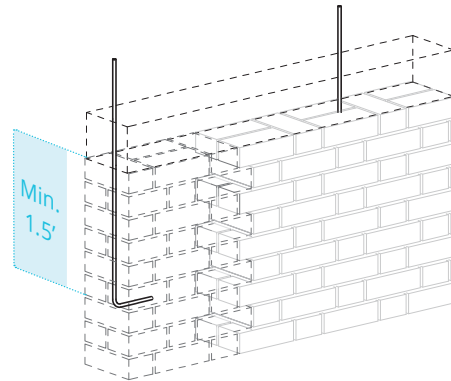

**B Bolt Connection:** A steel rod is cast into the wall and a bolt is used to secure the ring beam. This option is appropriate for timber and RC ring beams

**Section [not to scale]**

Wall is capped with a ring beam and approximately 1' of additional wall build up

Additional wall build up ~1'  
Ring beam

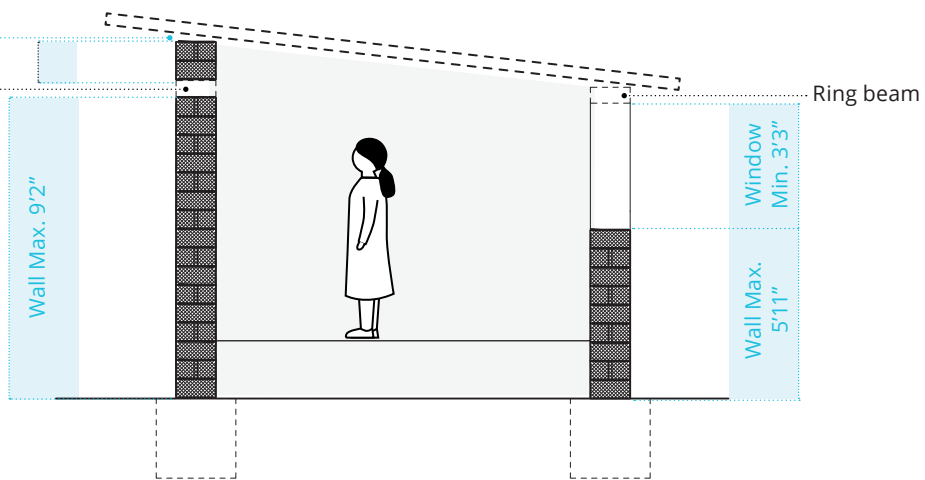

**SEISMIC CONSIDERATION**

- Limit wall height to 7'10"
- Use piers at the corners and in the middle of the long wall.
- Use the bolted connection.
- Use a seismically improved timber or bamboo ring beam (see Design Information, Ring Beam)



**Variation**

Replacing lime with Cement for stabilisation:  
+ Buildability  
- Sustainability  
Replacing tie with bolt connection:  
+Stability  
- Buildability



**Maintenance**

Repair render if damaged.  
Replace wire/rope in tied connection if damaged/rusted.



**Health and Safety**

Lime/Cement used in stabilisation can burn skin. Wear gloves and boots.



**Specification**

Stabilised earth  
Stabilised render



Wall Component

# Burnt Brick

## 3D view

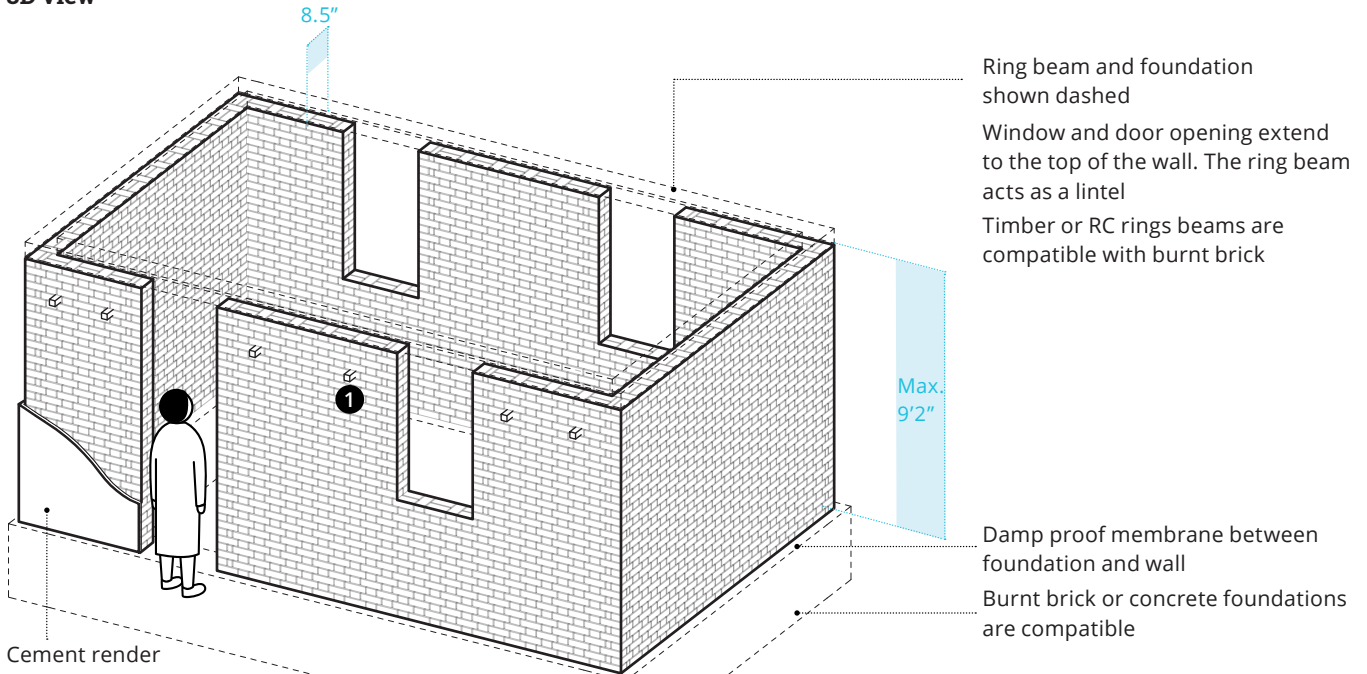

### Brick bond corner detail

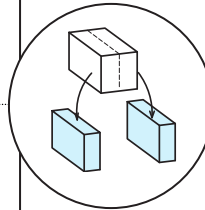
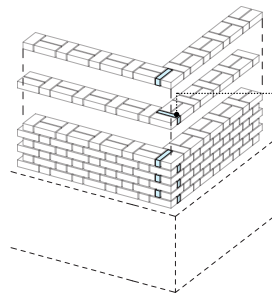

Brick bonds and half bricks must alternate as indicated in order to connect the four walls together. Half bricks are also required at openings

## Plan [Not to scale]

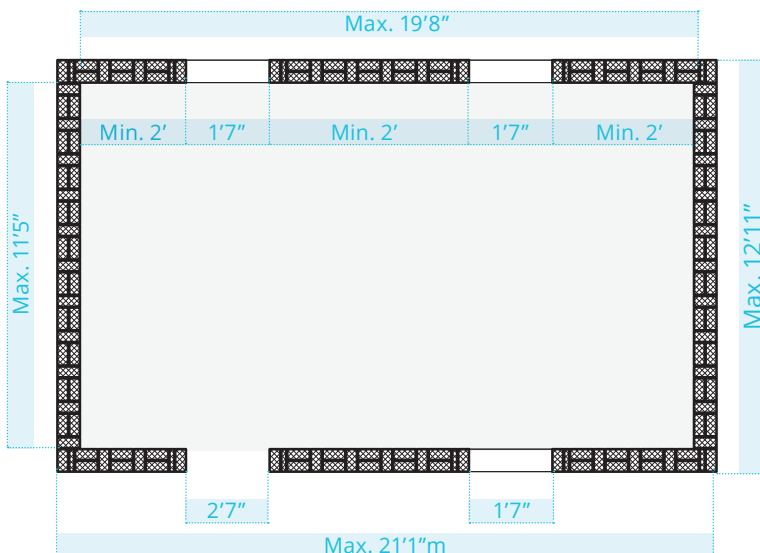

1

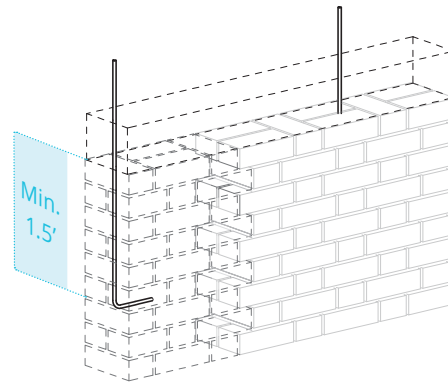
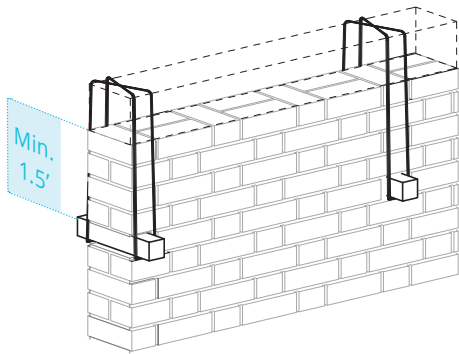

**(A) Tie Connection:** A wooden peg is cast into the wall and wire used to secure the ring beam. This option is easier to build and appropriate for timber and bamboo ring beams.

**(B) Bolt Connection:** A steel rod is cast into the wall and a bolt is used to secure the ring beam. This option is appropriate for timber and RC ring beams

**Section [not to scale]**

Wall is capped with a ring beam and approximately 1' of additional wall build up

Additional wall build up ~1' Ring beam

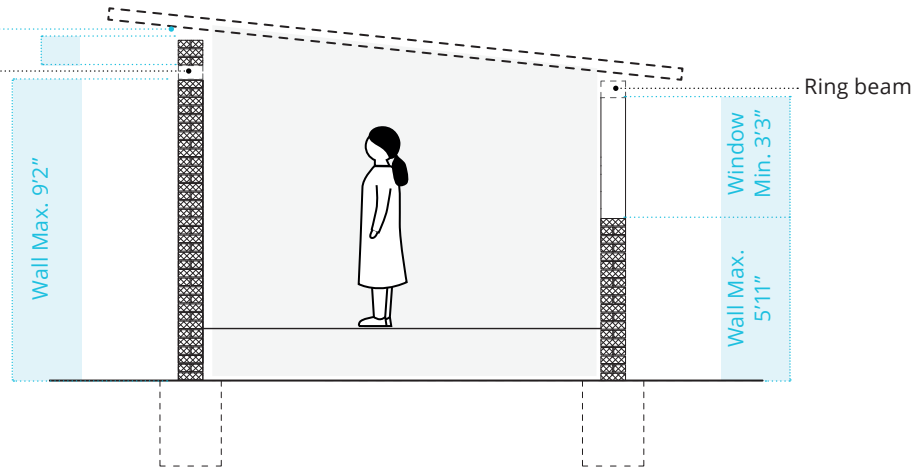

**SEISMIC CONSIDERATION**

- Limit wall height to 7'10"
- Use piers at the corners and in the middle of the long wall.
- Use the bolted connection.
- Use the reinforced concrete ring beam

**Variation**  
 Replacing tie with bolt connection:  
 +Stability  
 - Buildability

**Maintenance**  
 Repair render if damaged.  
 Replace wire/rope in tied connection if damaged/rusted.

**Health and Safety**  
 Lime/Cement used in mortar and render can burn skin. Wear gloves and boots.

**Specification**  
 Burnt bricks  
 Block laying



Wall Component

# Concrete Block

## 3D view

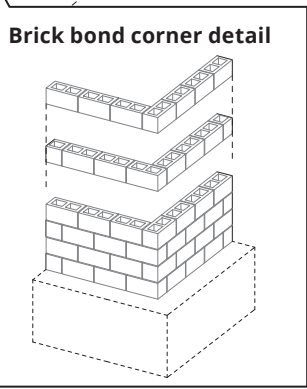
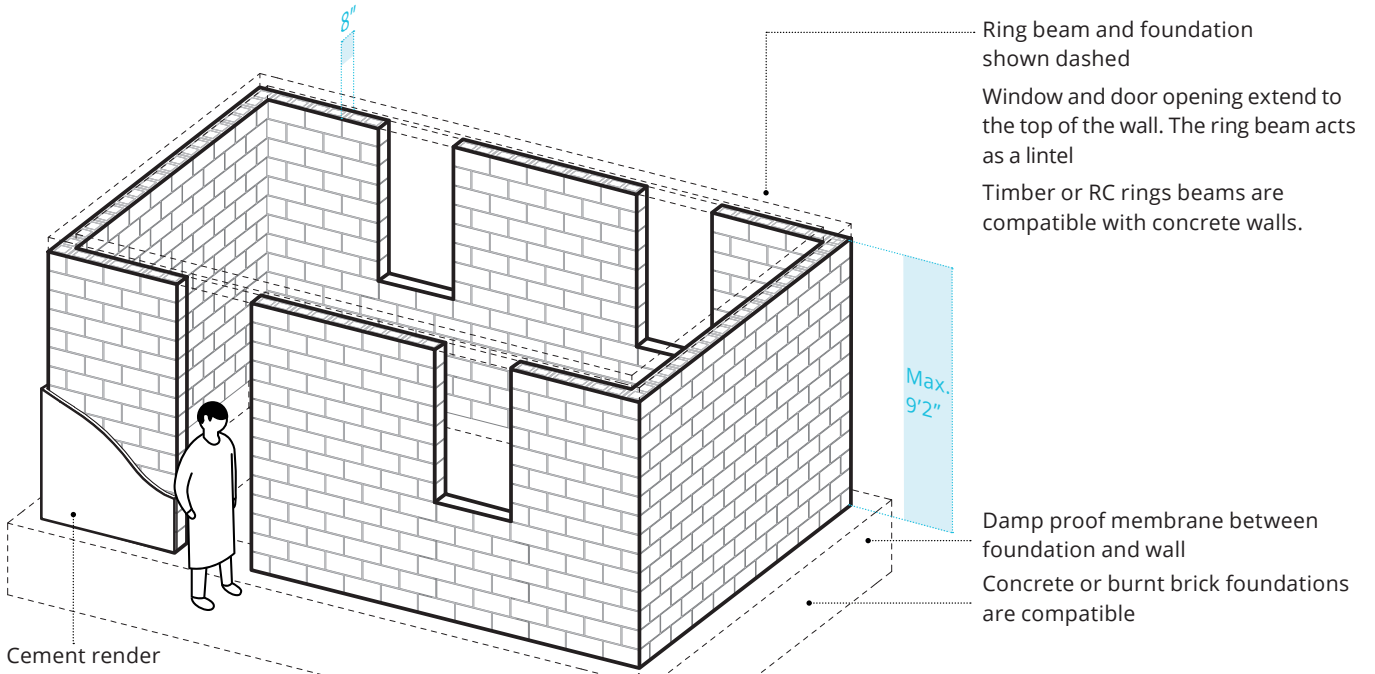

## Plan [Not to scale]

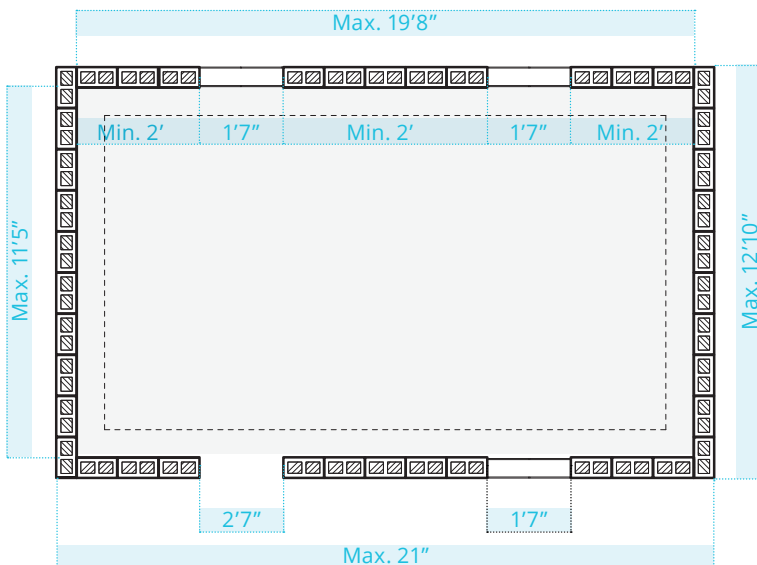

1

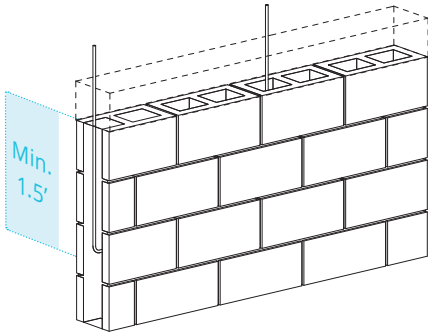

**Bolt Connection:** A steel rod is cast into the wall within the block cells if using hollow core blocks, or between the block courses if using solid blocks. If hollow block are used, the block cell with the bolt should be filled with concrete. This option is appropriate for an RC ring beam, where the bolt is cast into the ring beam.

**Section [not to scale]**

Wall is capped with a ring beam and approximately 1' of additional wall build up

Additional wall build up ~1' Ring beam

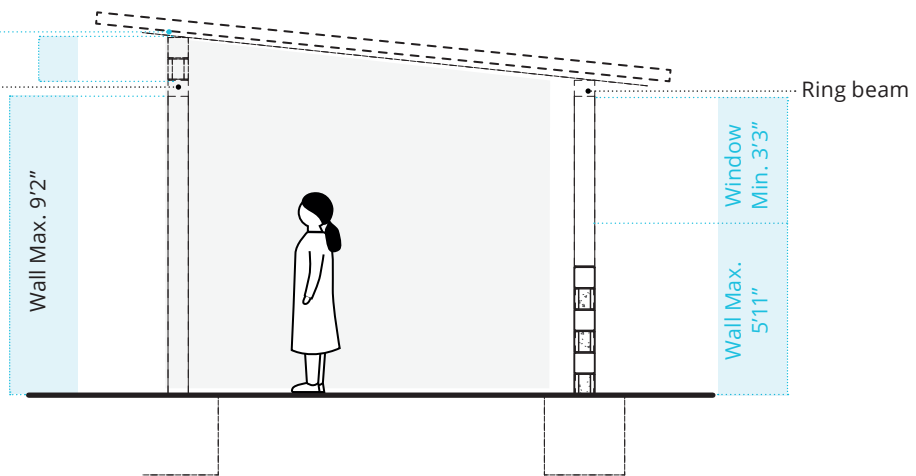

**SEISMIC CONSIDERATION**

- Limit wall height to 7'10"
- Use an RC ring beam
- Add vertical and horizontal wall reinforcement, 10mm diameter vertical bar every 3 cells + 10mm diameter horizontal bar every 3 courses, with additional 12mm diameter vertical bars in corners and next to openings. Note that adding reinforcement means anchoring to foundation.

<p><b>⚡ Maintenance</b> Repair render if damaged.</p>	<p><b>⚠ Health and Safety</b> Cement used in blocks, mortar and render can burn skin. Wear gloves and boots.</p>	<p><b>📋 Specification</b> Concrete Block laying</p>
---	--	---

 Roof Component

# Bamboo

### SEISMIC CONSIDERATION

The following measures will improve performance: Add nails between the ring beam and the roof rafters (nails should be pre-drilled to avoid splitting the bamboo).

### Tie Connection

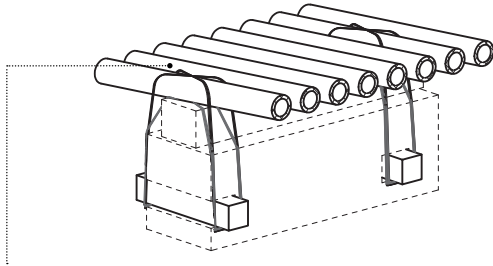

Only this method is suitable for bamboo roofs. Wire/rope/rattan is used to tie the roof structure to the ring beam and wooden pegs cast into the wall

### Bamboo Rafter Orientation

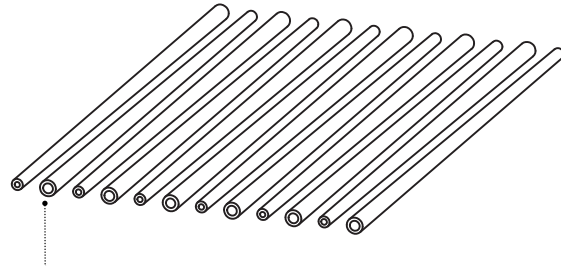

Bamboo lengths to be alternated based on the diameter of each end

### 3D view

#### Roof build up:

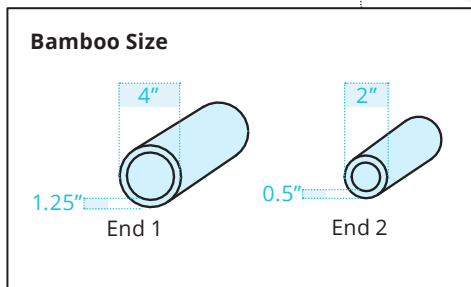
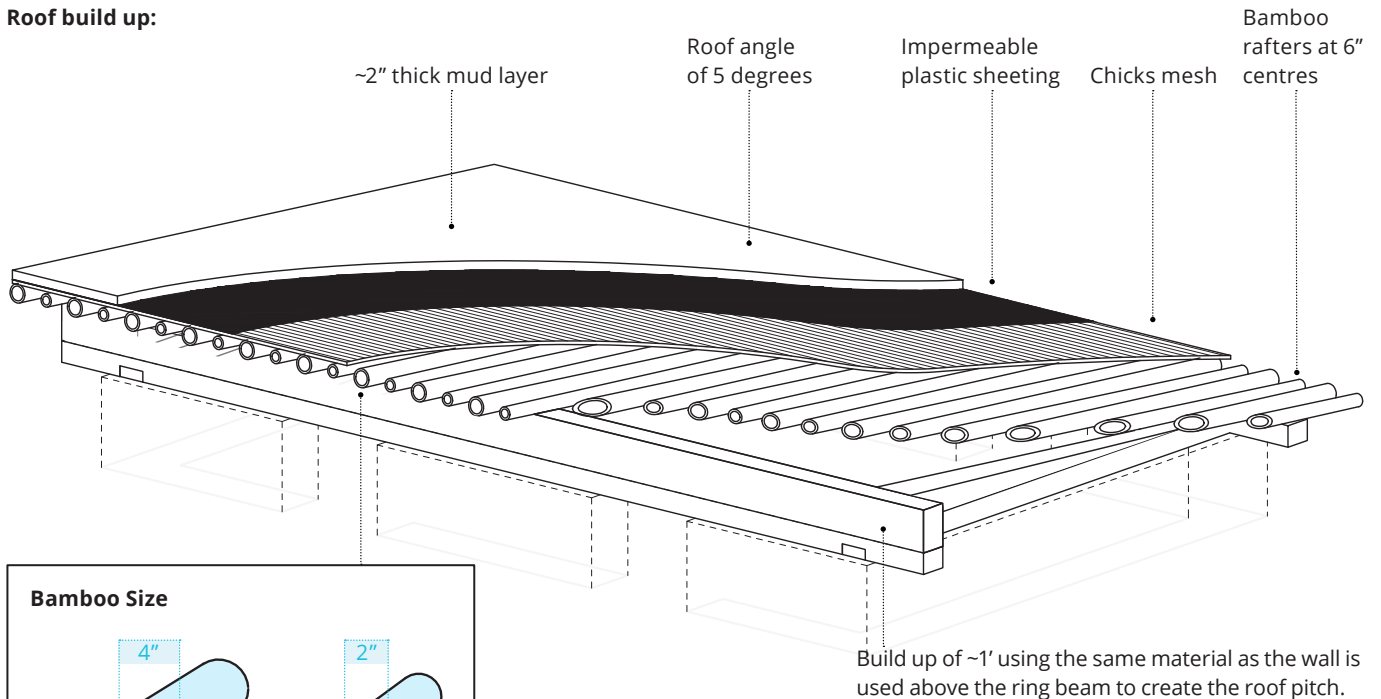

**⚡ Maintenance**  
Ensure sloped drainage is maintained  
Remove termite tracks.  
Replace deteriorated bamboo members  
Repair any leaks

**⚠ Health and Safety**  
Care required when working at height

**📋 Specification**  
Bamboo

# Timber

**SEISMIC CONSIDERATION**  
 The following measures will improve performance:  
 Use bolted connection  
 Add nails between the ring beam and the roof rafters.

## Tie Connection

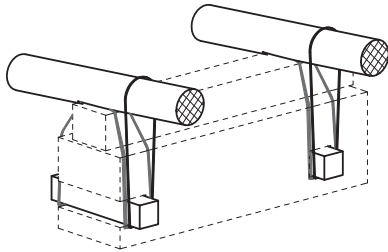

Wire/rope/rattan is used to tie the roof structure to the ring beam and wooden pegs cast into the wall. This option is easier to build and deconstruct.

## Bolt Connection

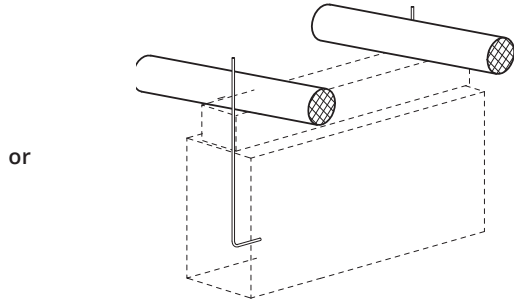

A steel rod is cast into the wall and threaded through holes drilled through the rafter and ring beam. This option appropriate only for timber or concrete ring beams

## 3D view

### Roof build up:

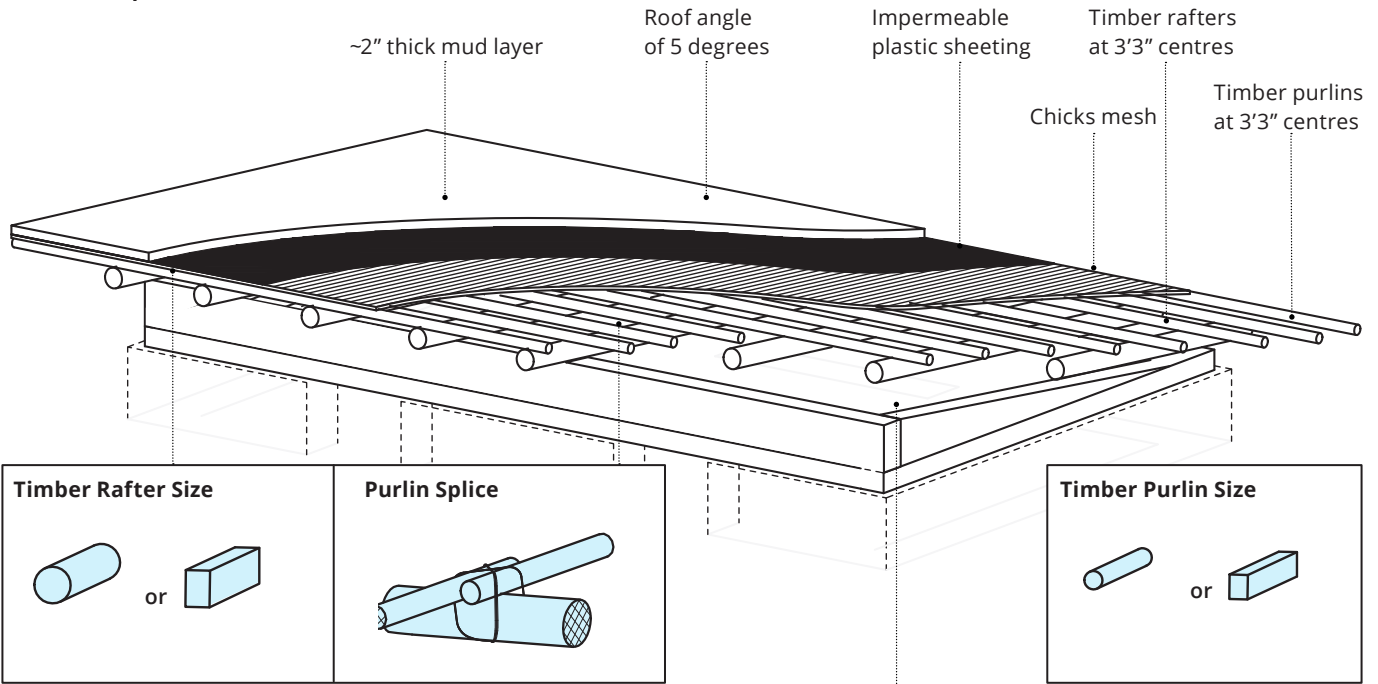

**Timber Rafter Size**

Timber rafters can be square sawn (6" deep, 4" wide) or circular (6" diameter). If only smaller sections can be sourced, use at a closer spacing.

**Purlin Splice**

If purlins require splicing, lengths to be overlapped and tied as they span the rafters

**Timber Purlin Size**

Timber purlins can be square sawn (4" deep, 3" wide) or circular (4" diameter). If only smaller sections can be sourced, use at a closer spacing.

Build up of ~1' using the same material as the wall is used above the ring beam to create the roof pitch.

 **Variation**  
 Replacing tie with bolt connection:  
 +Stability  
 - Buildability

 **Maintenance**  
 Ensure sloped drainage is maintained  
 Remove termite tracks.  
 Replace deteriorated Timber members  
 Repair any leaks

 **Health and Safety**  
 Care required when working at height

 **Specification**  
 Timber

 Roof Component

# Steel

## Tie Connection

**SEISMIC CONSIDERATION**  
 This is a weak connection because it does not transfer lateral load, don't use in a seismic zone

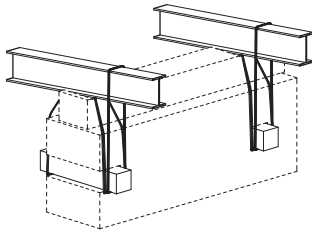

Wire/rope/rattan is used to tie the roof structure to the ring beam and wooden pegs cast into the wall. This option is easier to build and deconstruct.

## 3D view

### Roof build up:

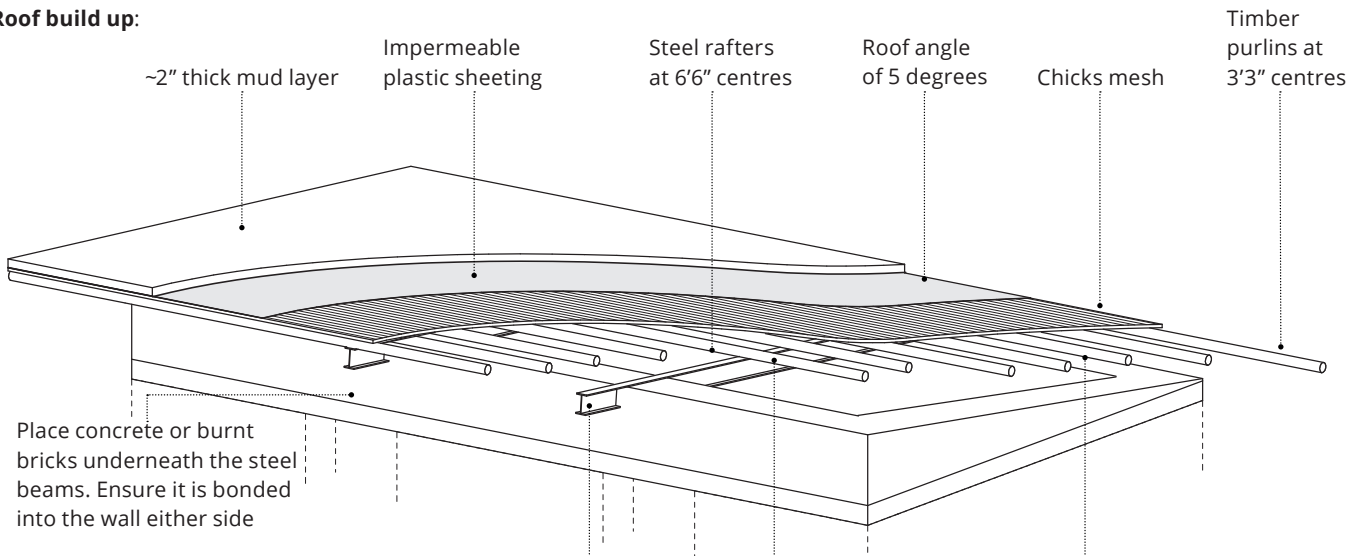

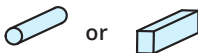
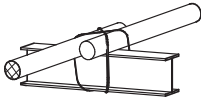

Steel Rafter Size	Timber Purlin Size	Purin connection
		

Steel rafters to have a min. depth of 6", and weight of 3kg/ft

Timber purlins can be square sawn (4.5" deep, 2" wide) or circular (4.5" diameter). If only smaller sections can be sourced, use at a closer spacing.

If purlins require splicing, lengths to be overlapped and tied as they span the rafters

 **Maintenance**  
 Ensure sloped drainage is maintained  
 Repair any leaks

 **Health and Safety**  
 Care required when working at height  
 Steel beams are heavy, take care when lifting

 **Specification**  
 Steel  
 Timber/bamboo

# Ring Beams

**SEISMIC CONSIDERATION**  
For bamboo and timber beams, add horizontal diagonals in the corner, or horizontal diagonals across the roof plane.

## Bamboo ring beam

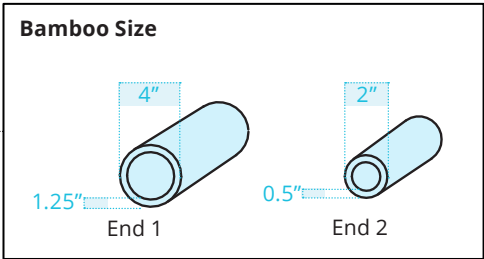
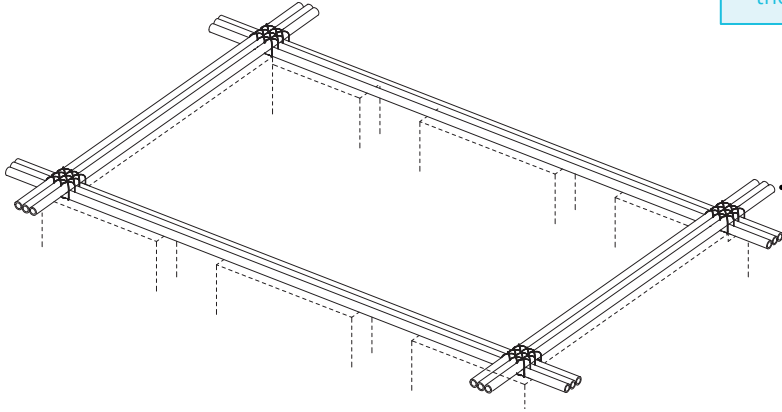

## Timber ring beam

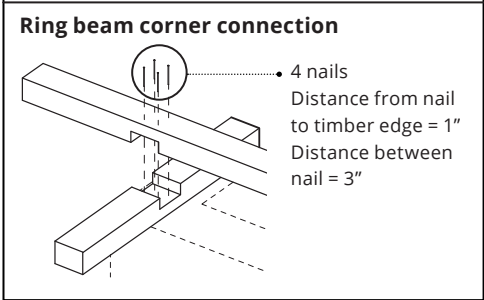
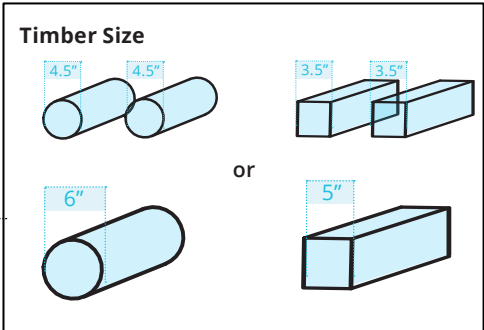
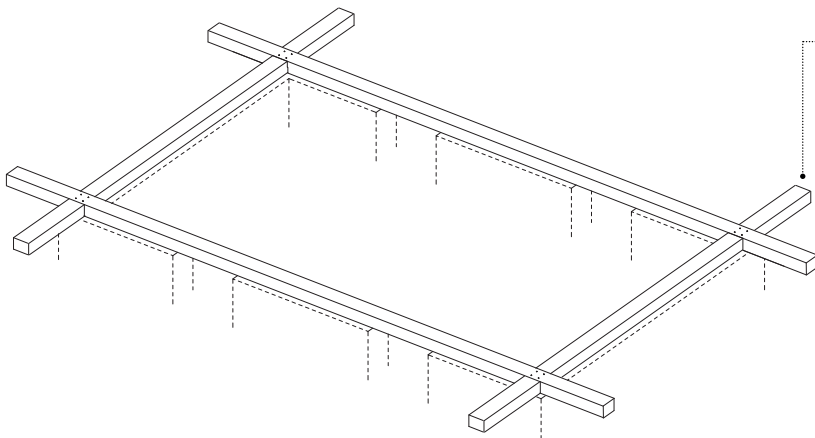

## Reinforced concrete ring beam

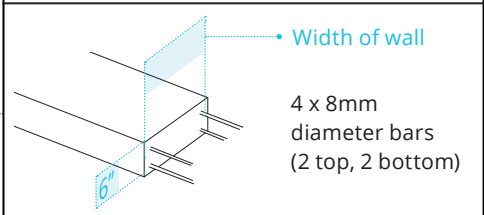
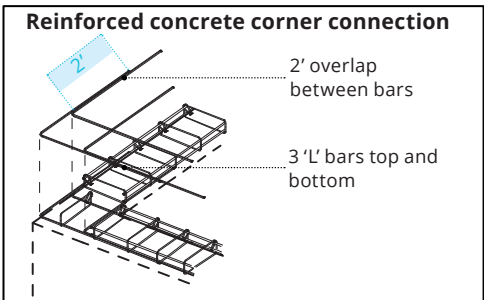
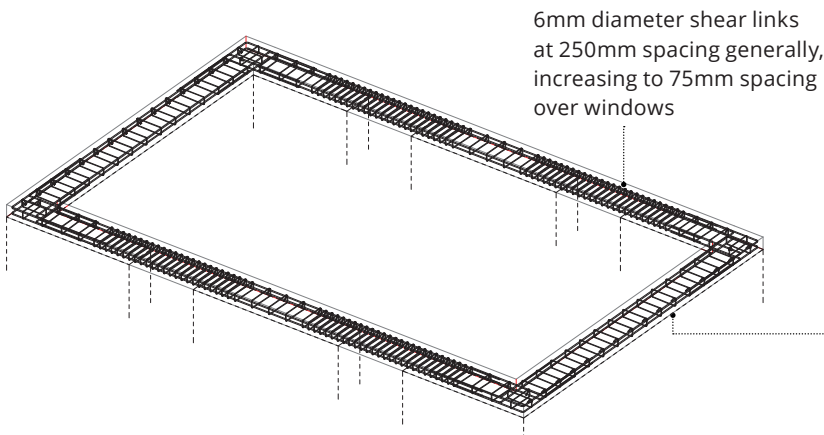

**Variation**  
Bamboo and Timber options allow easy veranda extension

**Maintenance**  
Care required when working at height  
Cement used in RC ring beam burns. Wear gloves.

**Health and Safety**  
Care required when working at height

**Specification**  
Steel  
Concrete  
Timber  
Bamboo

# Windows and Doors

Openings should be inherently private and secure by design, therefore either shutters or jali windows should be provided. Openings should not be left empty.

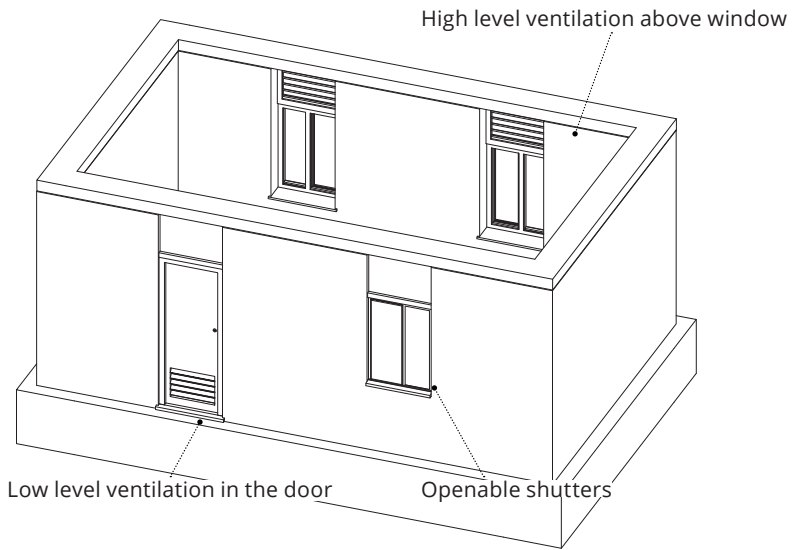

## Window shutters

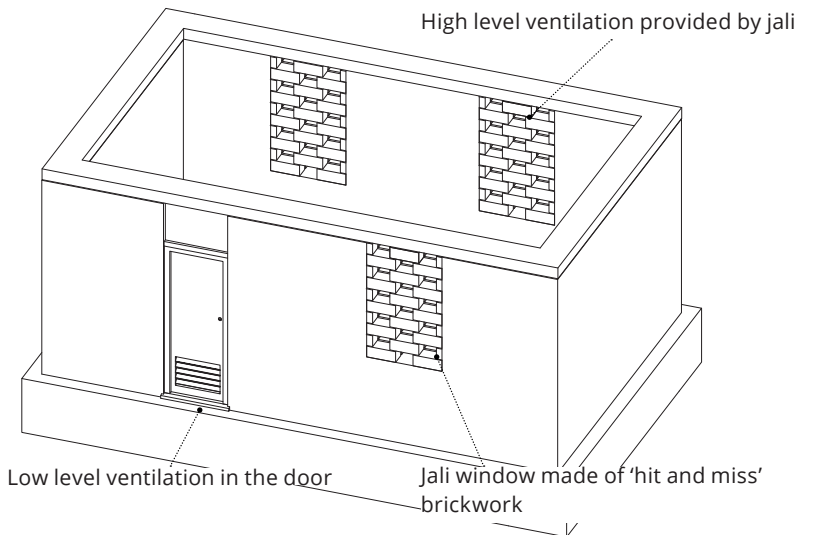

## Jali Screen

Using the ring beam as a lintel is more efficient structurally but can result in a larger window, which may be more expensive for the window shutter option

A more conventional option is to use a separate lintel. Ensure that high level ventilation is still provided in the window shutter option

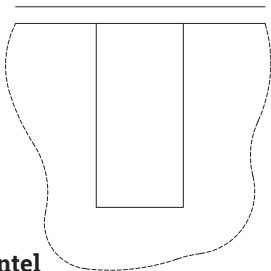

Ring beam as lintel

or

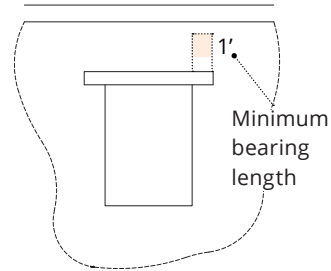

Lintel

- Variation**
- Windows with shutters
  - sustainability
  - +thermal comfort
  - Hit and miss brickwork
  - +sustainability
  - thermal comfort

# Platform and Toes

A raised floor is included as standard in all of the designs, to provide protection for people and belongings during a flood.

A toe can be built to encourage drainage away from the shelter, and sacrificial protection of the base, helping with rain resistance.

A platform can be used to extend the protected area to outside the building.

It should be noted that these additions do not help the structure of the building during a flood, and shouldn't be used in lieu of correct water resilient material choice and placement.

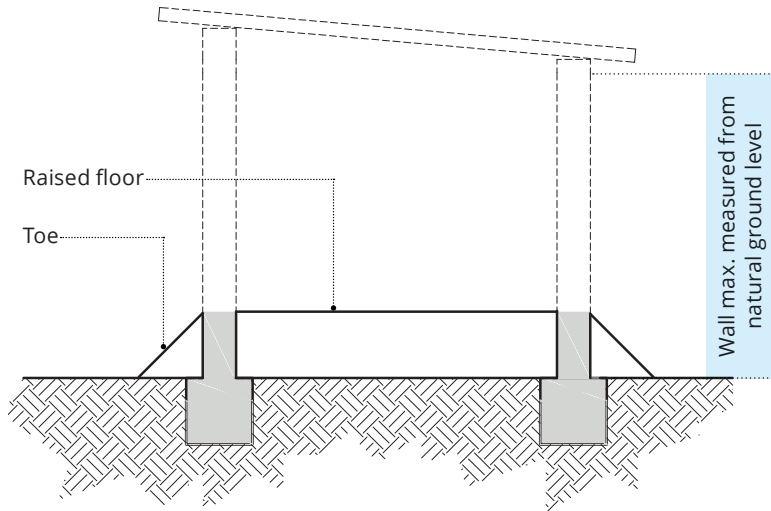

**Toe addition with raised floor**

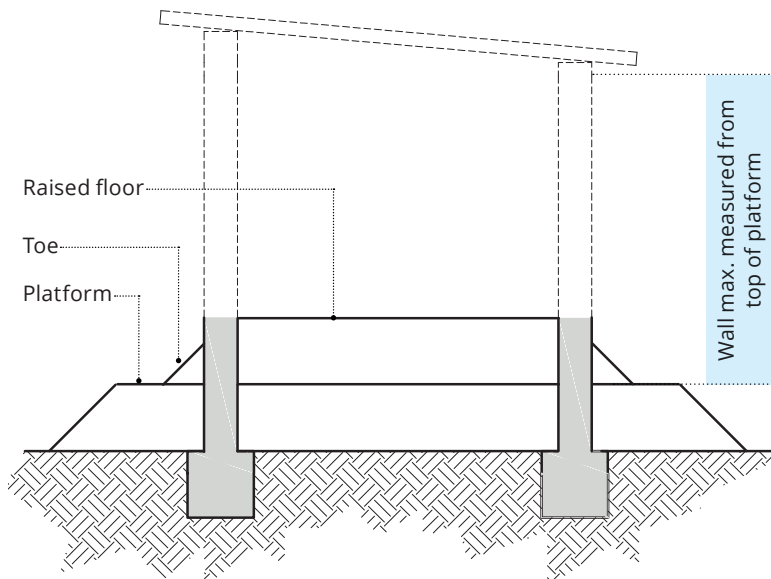

**Platform addition with raised floor**

For the earth construction options, the stabilised material (shown as shaded in grey) should be used, as minimum, to the same level as the raised floor/platform, otherwise the structure will fail before the flood has reached the floor level, and any protection of belongings is undermined.

Foundations must be placed below natural ground level and not within a plinth

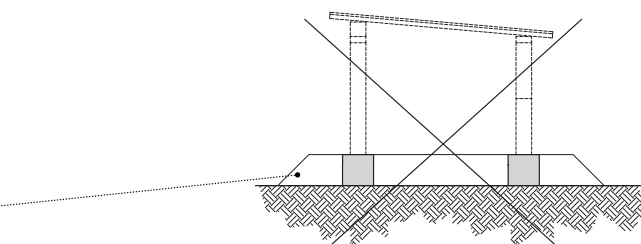

**Foundation position**



**Maintenance**  
Repair and replace platforms/toes as they deteriorate



**Health and Safety**  
Lime/Cement used in stabilisation can burn skin. Wear gloves and boots.



**Specification**  
Stabilised render



# 04

---

# Supporting Information

---

This chapter contains supporting information in relation to material specification, cost estimates (financial and carbon) and a notes sheet which may be useful as part of the design decision tool.

# Specification: Bamboo

## Condition<sup>1,2,3</sup>

- Straight pieces of bamboo should be used, any bending and curvature will affect the bamboos ability to take load.
- Split or cracked bamboo should be rejected.
- Bamboo showing signs of beetle or termite attack should be rejected.
- Bamboo should be mature at point of harvesting; at least four years old.
- Bamboo should be properly seasoned.
  - Season the bamboo by allowing it to dry naturally for 2-3 months in a covered and protected area, elevated above ground, and allowing natural ventilation around and in-between the culms.
- All storage of bamboo should be above ground and protected from the rain, and with ventilation allowed between culms.

## Treatment<sup>1,2,3</sup>

Red oxide paint and Mobil/slump oil should be avoided as they are ineffective

- Whilst painting/coating in mobil oil gives some level of protection, since the coating only reaches the outer layer of the bamboo it is limited in it's effectiveness
- It's effectiveness is further diminished by the fact that bamboo expands and shrinks which will crack the layer of protection, allowing access for beetles, termites and water.
- Mobile Oil is a known carcinogen, with risks during application, use, and disposal. Risks are to workers, house occupiers, and the wider community if it reaches the ground, drinking water, crops, or if burnt the air.

Soaking bamboo in water washes out some of the starch, making the bamboo less attractive to beetle attack. It has no effect however on its susceptibility to termite and fungi attack.

The water treatment method can be improved with the following:

- Break the nodes of the culms, or drill two holes into each internodal region, to allow water to enter the centre of the culm.
- Ensure the culms are submerged completely.
- Submerge the columns for long periods, ideally 6-8 weeks.

## Boron Treatment<sup>2</sup>

Boron is one of the few good treatment methods for bamboo.

Boron is a non-toxic safe to use chemical which protects effectively against beetles and termites.

It is possible for treatment to be cost effective, with examples of it being done for a 20-50% cost increase compared to untreated bamboo, however because of the relative cost and complexity associated with treatment with boron, it is better suited to a centralised facility, as oppose to treating on a household level.

For further information on bamboo, refer to Design Guide for Engineered Bahareque Housing<sup>3</sup>, IStructE Structural use of bamboo Parts 1-4<sup>2</sup>, and the Humanitarian Bamboo Guidelines, humanitarianbamboo.org

<sup>1</sup>See Liese, W., Kumar, S. (2003) INBAR Technical Report 22: Bamboo Preservation Compendium. Beijing, INBAR

<sup>2</sup>Kaminski S., Lawrence A., Trujillo D. & King C. (2016) Technical Note Series: Structural use of bamboo

<sup>3</sup>Kaminski S., Lawrence A. y Trujillo D. (2016d) INBAR Technical Report No. 38: Design Guide for Engineered Bahareque Housing. INBAR, Beijing

# Specification: Stabilised and non stabilised earth construction

Minimum Strength:  
Non-seismic: 2.5N/mm<sup>2</sup>  
Seismic: 5N/mm<sup>2</sup>

## Mix

Suitable soils must be used for earth construction. Mix (proportion of clay, sand and where required cement or lime) to be determined by trial and testing. For details on the mixing process, see Further Information, Soil preparation.

The suitability of soil for unfired earth blocks (whether stabilised or not) may be determined through a variety of tests. Some may be carried out in the field with no equipment at all while others are expensive lab tests. The aim typically is to determine:

1. Composition (gravel/sand/silt/clay)
2. Plasticity
3. Optimum moisture content
4. Organic matter content, which should always be removed for earth construction.

Details of simple field testing, such as the jam jar test, can be found in the 'Lime Stabilized Construction, A Manual and Practical Guide' by Strawbuild<sup>4</sup>.

## Stabilised

The following table details soils which are unsuited to block making and should be avoided<sup>5</sup>

Cement stabilised	Topsoils Organic matter content greater than 1-2% Highly expansive soils Soils with soluble salts in sufficient quantities to impair strength or durability (found by trial testing)
Lime stabilised	Topsoils Organic matter content greater than 20% Soils with combined clay + silt content less than 30% Soils with excessive sulphates

## Lime Stabilised

Lime stabilisation requires trial and testing to achieve. A shrinkage test can be used to determine initial suitability, with shrinkage between 10 and 60mm indicating a suitable soil.

The table below details suitable soil composition<sup>5,6</sup>. The 'Lime Stabilized Construction, A Manual and Practical Guide' by Strawbuild offers more detailed information and should be consulted when undertaking lime stabilisation<sup>4</sup>.

Lime stabilisation		
	Australian earth construction, lime stabilisation	Auroville, compressed earth blocks, lime stabilised
%fine gravel	5-70%	15
%sand		30
%silt	10-60%	20
%clay	20-60%	35

## Cement Stabilised

For cement stabilised blocks, a linear shrinkage test can also indicate the correct cement quantity, with further trial and testing required, as shown in the below table<sup>7</sup>

Gap	Mix ratio		
	Soil	Cement	%
Less than 15mm	Too much sand — add clay		
15 - 30mm	16	1	6.3%
30 - 45mm	14	1	7.1%
45 - 60mm	12	1	8.3%
More than 60mm	Too much clay — add sand		



Suitable soil composition is detailed in the table below<sup>5,6</sup>.

Cement stabilisation		
	Australian earth construction, cement stabilisation	Auroville, compressed earth blocks, cement stabilised
%fine gravel	45-80%	15
%sand		50
%silt	15-30%	15
%clay	up to 25%	20

<sup>4</sup>IOM, Strawbuild, Lime Stabilized Construction, A Manual and Practical Guide

<sup>5</sup>Walker, P. HB195-2002. The Australian earth building handbook. Standards Australia, 2002.

<sup>6</sup>Auroville earth institute <http://www.earth-auroville.com/index.php>.

<sup>7</sup> Davis, J and Lambert, R. Engineering in emergencies. ITDG, 1995.

# Specification: Stabilised and non stabilised earth block making

## Soil preparation

1. Dry the soil
2. Crush the soil.
3. Pass soil through a 5mm or 6mm sieve to remove larger stones
4. Depending upon the grading of particles in the soil, additional clay/sand/ gravel may be blended in.
5. If required, mix stabiliser until mixture is all the same colour. This is generally done by volume. It is best done in relatively small batches to ensure consistency and thorough mixing.
6. Water should be mixed gradually and thoroughly by hand. The amount required is likely to vary, but 10%–15% by volume may be used as a starting point. Dropped from shoulder height, the mixture should break into two or three pieces. If it crumbles it is too dry. If it is too wet it will remain as one piece. Concrete mixers are not suited to soil mixing as the soil will stick within the sides and not mix properly.
7. Mixing time should be at least eight minutes.
8. “Holdback time” between mixing and block production should be kept below one hour at the most where soil is cement-stabilised, as strength can reduce. Where lime is used, strength may increase with holdback time.

## Block size

Stabilised blocks to be 14”x 6.5” x 6.5”

Unstabilised blocks to be 14”x 6.5” x 3.25”

This means the unstabilised blocks will be lighter, and the two blocks can be easily identified.

## Curing

### Unstabilised

It is important that earth blocks are not allowed to dry out too quickly as this may cause cracking.

Blocks should be raised up or placed on plastic sheet to prevent loss of moisture to the ground.

Blocks should be covered over with plastic sheet or cloth to prevent evaporation and protect against rain.

### Stabilised

Like concrete, earth construction gains strength with age.

It is important that earth blocks are not allowed to dry out too quickly as this may cause cracking.

Blocks should be raised up or placed on plastic sheet to prevent loss of moisture to the ground.

Blocks should be covered over with plastic sheet or cloth to prevent evaporation and protect against rain.

Blocks should be kept damp for several days by sprinkling with a watering can or similar.

Blocks may initially be stored flat before being stacked into piles.

Blocks stabilised with cement should be cured for a minimum of 14 days, ideally 30 days.

Blocks stabilised with lime should be cured for at least 30 days.

### Field testing

Field testing should be undertaken for each batch of blocks made.

Blocks should survive a drop test and a bending test. Stabilised blocks should also survive a bucket test.

### Mortar

Use the same mix as for blocks. For stabilised blocks, use stabilised mortar, for unstabilised blocks use unstabilised mortar.

Mortar beds = 0.5"



Drop a block from 3 feet, good blocks do not break except at the edges

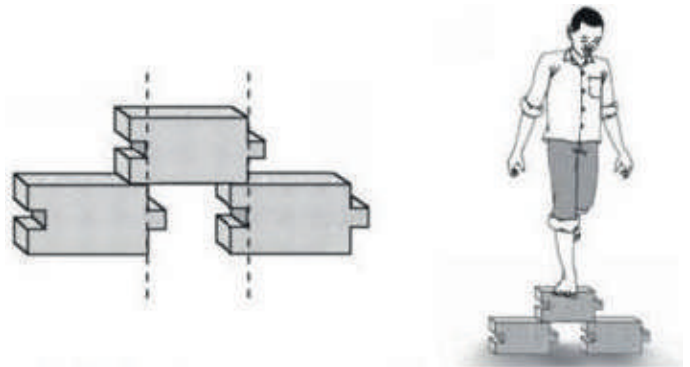

Place blocks as shown, good blocks do not break when you stand on them



Place block in water for 24 hours, good blocks will not wash away

Rudimentary block tests: (L) drop test; (C) bending test; (R) durability test<sup>8</sup>.

<sup>8</sup>T4T. Interlocking stabilised soil block: machine operation manual. T4T.

# Specification: Block laying

Correct block laying is required to achieve strength of the wall.

The brick bond used for the wall ensures that vertical joints in consecutive courses do not align, and are a minimum of a quarter of a block length apart.

All blocks to be cleaned and wetting before mortar is applied

Mortar should not dry out before bricks are positioned, so do not spread it out more than 5 bricks at once.

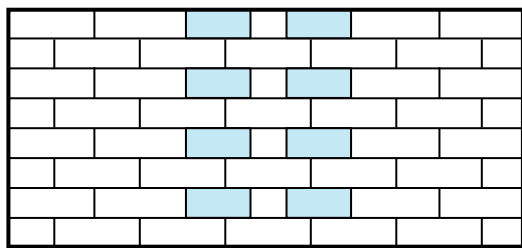

Elevation

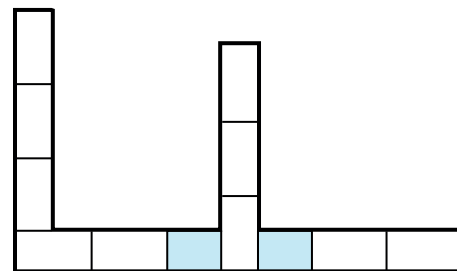

2nd course

Walls should be fully bonded at returns and corners.

Slushing, where mortar in vertical joints is laid after the block has been placed, should not be done, as this prevents the vertical mortar from being compressed as the block is laid.

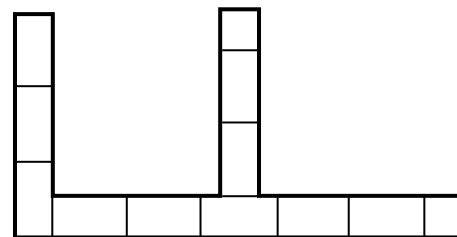

1st course

Mortar should not be too wet, else it will shrink and crack.

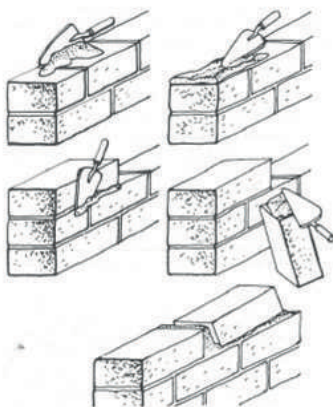

Vertical mortar applied to block so that it may be compressed as the block is laid<sup>9</sup>

<sup>9</sup>Houben, H and Guillaud, H. Earth construction: a comprehensive guide. ITDG, 1994.

# Specification: Concrete

Minimum concrete strength to be 21MPa (Pakistan building code).

30Mpa can be achieved with the following mix,

## Mix

Ordinary Portland Cement: Sand: Aggregate = 1:2:4

For non-structural concrete (ie for blinding) the mix may be adapted to save cost, such as 1:4:12

Concrete to be thoroughly mixed for at least 5 minutes.

The cement, sand, aggregate and water must be evenly distributed throughout once mixing is complete. The mix should be a uniform colour.

All concrete should be thoroughly compacted in order to release trapped air bubbles because air pockets weaken the concrete.

## Concrete curing

Concrete should not be allowed to dry out too quickly. This is to prevent cracks resulting from the surface drying out faster than the inner concrete.

Proper curing enables concrete to achieve its full strength and durability.

After it is poured it should be protected from direct sunlight. It should be covered with plastic sheet/ cements bags or similar and watered for up to 7 days.

After 7 days the concrete will have achieved 2/3 of its design strength.

## Concrete testing

A slump test should be performed for each concrete mix to ensure the correct consistency. Too much water commonly decreases the strength of concrete, a slump test helps to avoid this occurrence.

## Slump Test

A slump test should be carried out every time concrete is mixed.

### Why?

A slump test will tell you if there is too much or too little water in the concrete mix.

Putting too much water in the concrete will make it weak.

Putting too little water in the concrete makes it hard to work with.

### STEP 1

Make a metal cone that is 300mm tall, 100mm wide at the top and 200mm wide at the bottom. Each end of the cone should be open. Ensure the cone is cleaned before each use.

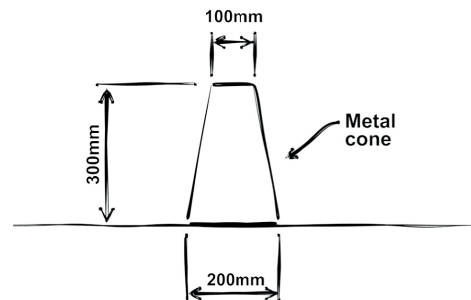

### STEP 2

Place the cone on a flat surface. Fill 1/3rd of the cone with fresh concrete.

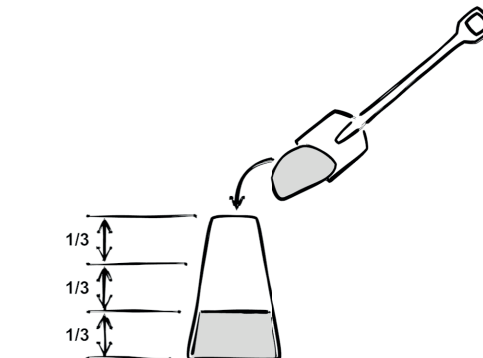

**STEP 3**

Compact the concrete 20 times with a rod or stick.

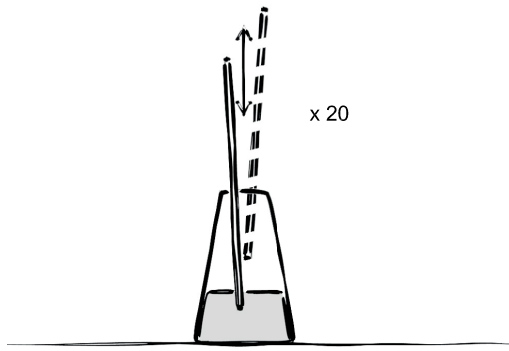
**STEP 4**

Repeat steps 2 and 3 twice so that the cone is now full of concrete. Level the top surface.

**STEP 5**

Carefully remove the slump cone.

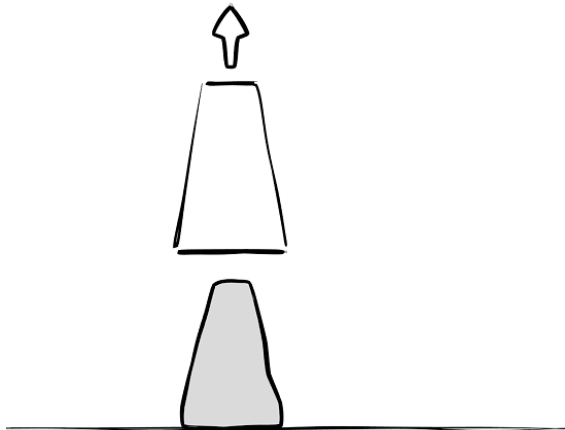
**STEP 6**

Using an Iron rod and tape measure, measure the slump from the highest point of the concrete to the top of the cone.

The Slump should measure 50mm.

If the slump measures more than 50mm it means there is too much water in the concrete. Adding too much water to the concrete makes it weak.

If the slump measures less than 50mm there is not enough water in the concrete and it will be too stiff to use making it difficult to compact properly.

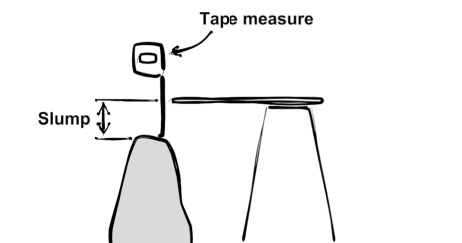

# Specification: Aggregate

- Stone aggregate should be used if available.
- Crushed angular gravel is preferred.
- Avoid rounded river gravel.
- Aggregate should be washed and clean, free of organic material/sand/silt/clay.
- Sizes evenly distributed between 5 and 20mm.
- Long thin shards of angular gravel should be discarded. (They will not compact as well and increase the likelihood of air pockets in the concrete.)
- If no stone aggregate is available, crushed burnt brick can be used.
- Brick has a lower compressive strength than stone. When used as aggregate it will therefore give concrete of lower strength.
- Ensure that brick has been fired evenly throughout.
- Sizes evenly distributed between 5 and 20mm.
- Long angular shards of brick to be discarded.
- Crushed brick should be soaked in water prior to being added to the mix. This is to reduce the amount of water that the porous brick leaches out of the mix.

# Specification: Timber

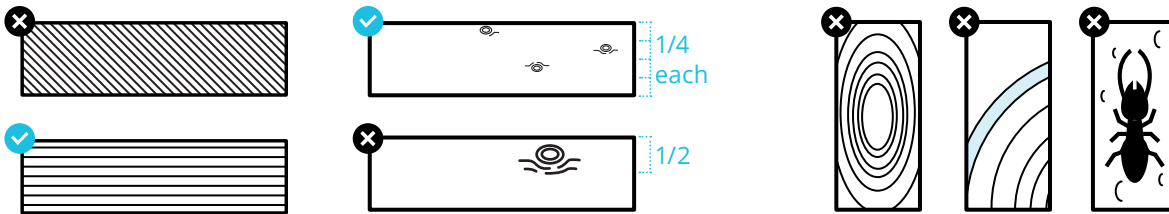

- The timber should be 'dry'. Timber that has not been properly dried is more likely to be bend and to split
- Timber should be as straight as possible and should have no large splits
- All timber should be stored and covered in neat stacks to prevent warping

## Sloping Grain

The grain of the timber should be straight. Sloping grain is not allowed. Timber with sloping grain is weak.

## Knots

- Knots are weaknesses in timber
- Timber with a lot of knots is not allowed
- Small knots that are less than 1/3 of the width of the timber are allowed
- When joining one piece of timber to another make sure that there are no knots near to the connection

## Boxed heart

- The piece of timber that is cut from the very middle of the tree is known as boxed heart
- This piece of timber will split easily and is therefore weak

## Sapwood

- Timber cut from the edge of the tree trunk is not allowed

## Termites

- Timber that shows signs of termites or any other insect attack is not allowed

For further information on timber, see [humanitarian-timber.org](http://humanitarian-timber.org)

# Specification: Damp proof membrane

**Damp proof membrane**

Use a large, thick (thickest that is available) plastic sheet.  
300mm lap length at all joints Joints to be sealed top and bottom with heavy duty waterproof tape.  
Sheet to be inspected for any rips or tears. Repair to be carried out with suitable heavy duty waterproof tape.

# Specification: Render

## Render

Render should be applied in layers to allow for shrinkage.

Maintain a good bond between layers of render by roughening the previous layer before it has set, and wetting it before applying a new layer.

Keep render layers to a maximum of 0.5" thick

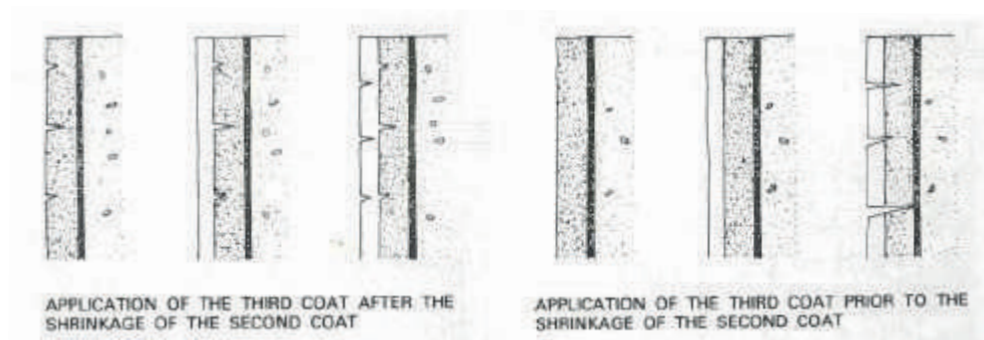

Application of render<sup>9</sup>

## Stabilised Render

For details on the stabilisation mix, see Specification: Stabilised and non stabilised earth construction.

Ensure that render is cured, see Specification: Stabilised and non stabilised earth block making, curing.

## Cement Render

See Specification: Concrete, non structural concrete and concrete curing

<sup>9</sup>Houben, H and Guillaud, H. Earth construction: a comprehensive guide. ITDG, 1994.

# Cost Estimates: Financial & Carbon

## Assumptions & Estimates

This section includes the cost assumptions and estimates used to evaluate the recommended design components (five foundation types, five wall types, and three roof types). Cost includes the capital financial cost of each component and the capital carbon cost of each component. The assumptions underlying these estimates are included where relevant so that users can compare and make adjustments where necessary. It's important to note that these estimates are merely estimates. They were developed in order to compare the relative costs of each component and outline design. These estimates should not be relied on to develop programme budgets or construction costs for the following reasons:

- Data are out of date. The material costs used are based on analysis of bills of quantities (BoQs) received from several shelter agencies mostly during 2016. The actual costs of these materials have presumably fluctuated since then and these estimates no longer reflect market prices.

- This is not a BoQ. The estimates are for the exact volume of materials required for each component but do not account for wastage or the lumpy nature of procurement, e.g. the exact volume of bricks are specified but bricks may need to be purchased by the tonne and there can be up to 25% breakage of materials. These issues are not included in the costs estimates.
- Labour and transport costs vary considerably. The estimates generally assume labour costs to be 20% and transport costs to be 5% of the material costs. However, this varies by location, material and situation. These variables are not included in the costs estimates.

Arup developed a detailed cost estimating model in Microsoft Excel in order to generate these estimates. Some extracts are included here for illustration. The full model may be found online. The user can update the excel file with specific design parameters (e.g. wall dimensions) and unit costs (e.g. linear metre of timber) in order to adapt the estimates to their designs.

Wall	Cost (PKR)	CO2 (kg)	Roof	Cost (PKR)	CO2 (kg)	Foundation	Cost (PKR)	CO2 (kg)	TOTAL		
									Cost (PKR)	Cost (\$)	CO2 (kg)
Loh Kat	15361	569	Timber	11410	311	In ground	3103	377	29874	284	1256
Loh Kat	15361	569	Timber	11410	311	Out of ground	13549	921	40320	383	1800
Loh Kat	15361	569	Bamboo	12071	241	In ground	3103	377	30535	290	1186
Loh Kat	15361	569	Bamboo	12071	241	Out of ground	13549	921	40981	389	1731
Lime Stabilised Layered Mud	9960	772	Timber	11410	311	Lime Stabilised Mud / Adobe	3222	401	24592	234	1484
Lime Stabilised Layered Mud	9960	772	Timber	11410	311	Burnt Brick	25975	2927	47345	450	4010
Lime Stabilised Layered Mud	9960	772	Bamboo	12071	241	Lime Stabilised Mud / Adobe	3222	401	25253	240	1414
Lime Stabilised Layered Mud	9960	772	Bamboo	12071	241	Burnt Brick	25975	2927	48005	456	3940
Lime Stabilised Adobe	10125	521	Timber	11410	311	Lime Stabilised Mud / Adobe	3222	401	24758	235	1233
Lime Stabilised Adobe	10125	521	Timber	11410	311	Burnt Brick	25975	2927	47510	451	3759
Lime Stabilised Adobe	10125	521	Bamboo	12071	241	Lime Stabilised Mud / Adobe	3222	401	25418	241	1163
Lime Stabilised Adobe	10125	521	Bamboo	12071	241	Burnt Brick	25975	2927	48171	458	3690
Lime Stabilised Adobe	10125	521	Steel	14736	390	Lime Stabilised Mud / Adobe	3222	401	28084	267	1312
Lime Stabilised Adobe	10125	521	Steel	14736	390	Burnt Brick	25975	2927	50837	483	3838
Fired Brick	40800	4332	Timber	11410	311	Burnt Brick	25975	2927	78185	743	7570
Fired Brick	40800	4332	Timber	11410	311	Concrete	23252	1566	75462	717	6208
Fired Brick	40800	4332	Bamboo	12071	241	Burnt Brick	25975	2927	78845	749	7500
Fired Brick	40800	4332	Bamboo	12071	241	Concrete	23252	1566	76122	723	6138
Fired Brick	40800	4332	Steel	14736	390	Burnt Brick	25975	2927	81511	774	7648
Fired Brick	40800	4332	Steel	14736	390	Concrete	23252	1566	78788	748	6287
Concrete Block	36863	2363	Timber	11410	311	Burnt Brick	25975	2927	74247	705	5601
Concrete Block	36863	2363	Timber	11410	311	Concrete	23252	1566	71524	679	4239
Concrete Block	36863	2363	Bamboo	12071	241	Burnt Brick	25975	2927	74908	712	5531
Concrete Block	36863	2363	Bamboo	12071	241	Concrete	23252	1566	72185	686	4169
Concrete Block	36863	2363	Steel	14736	390	Burnt Brick	25975	2927	77574	737	5680
Concrete Block	36863	2363	Steel	14736	390	Concrete	23252	1566	74851	711	4318

Cost estimates (financial and carbon) for all components and outline designs

COST (PKR)	Shelter wall type				
	Layered mud	Adobe	Fired brick	RC block	Loh Kat
Foundations	3,003	3,222	20,424	18,282	6,103
Walling	24,616	35,037	52,845	48,288	10,046
Doors & windows	3,067	3,046	3,013	3,013	3,080
Roof	12,071	11,410	14,736	14,736	12,071
<b>SUBTOTAL</b>	<b>42,756</b>	<b>52,715</b>	<b>91,018</b>	<b>84,320</b>	<b>31,299</b>

<b>Labour: + 20%</b>	<b>8,551</b>	<b>10,543</b>	<b>18,204</b>	<b>16,864</b>	<b>6,260</b>
<b>Transport: + 5%</b>	<b>2,138</b>	<b>2,636</b>	<b>4,551</b>	<b>4,216</b>	<b>1,565</b>
<b>TOTAL</b>	<b>53,446</b>	<b>65,894</b>	<b>113,773</b>	<b>105,400</b>	<b>39,124</b>

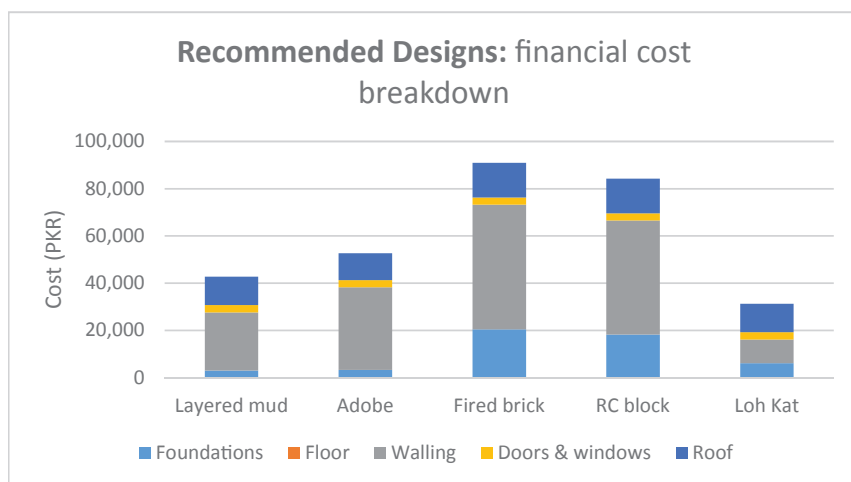

Financial cost breakdown by material type

CO2 (kg)	Shelter wall type				
	Layered mud	Adobe	Fired brick	RC block	Loh Kat
Foundations	399	401	2,302	1,231	33
Walling	1,616	3,822	5,167	2,888	448
Doors & windows	0	0	0	0	0
Roof	363	432	477	477	363
<b>TOTAL</b>	<b>2,377</b>	<b>4,655</b>	<b>7,946</b>	<b>4,596</b>	<b>843</b>

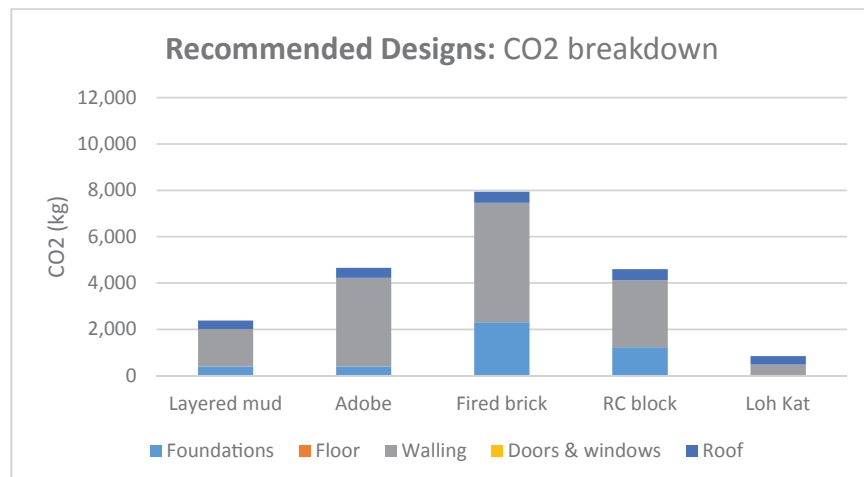

Carbon cost breakdown by material type

## FOUNDATIONS

Select and complete for 1 of the 3 following foundation shape options:

### 1. Compressed soil (with/ without cement or lime stabilisation)

Section Inputs:

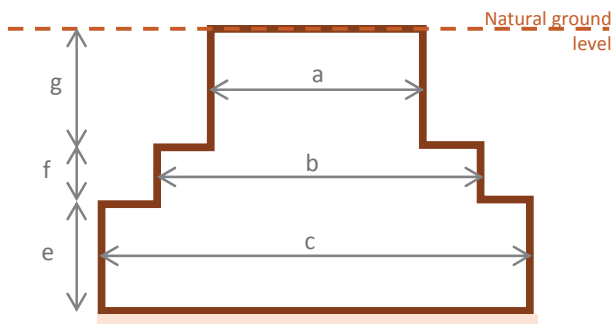

Notes:

a =	0.5	m
b =	0.5	m
c =	0.5	m
e =	0.75	m
f =	0	m
g =	0	m

total volume = 0.375 m<sup>3</sup> /m length

Section Outputs:

Material	Quantity /m wall length			Wall length	Cost	
Fired bricks + cement mortar	0.375	m <sup>3</sup>	801 kg	19.08 m	25,975	PKR
Adobe blocks + lime	0.375	m <sup>3</sup>	645 kg	19.08 m	3,222	PKR
Adobe blocks + cement	0.375	m <sup>3</sup>	702 kg	19.08 m	11,376	PKR
Layered mud + lime	0.375	m <sup>3</sup>	645 kg	19.08 m	3,016	PKR
Layered mud + cement	0.375	m <sup>3</sup>	702 kg	19.08 m	11,230	PKR
Hollow concrete block + cement mortar	0.375	m <sup>3</sup>	596 kg	19.08 m	23,252	PKR
Solid concrete block + cement mortar	0.375	m <sup>3</sup>	907 kg	19.08 m	29,962	PKR

Illustrative example of the foundation parameters included in the cost estimating model

## ADOBE WALLS

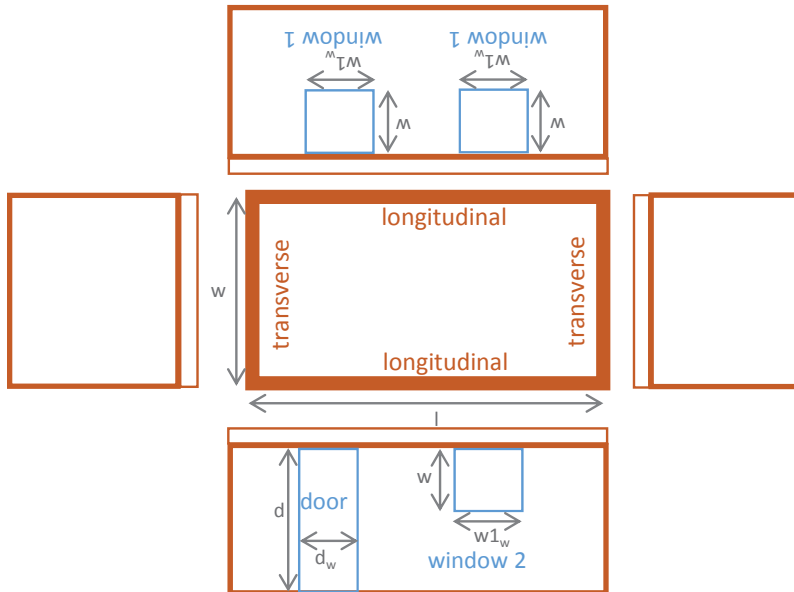
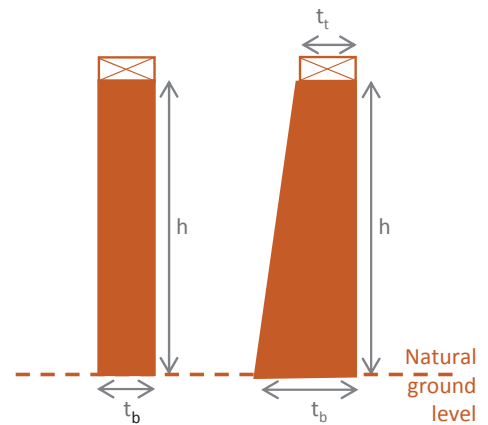
**Plan and Elevation key:****Section key:****Assumptions:**

Change in wall thickness is linear constant (so thickness can be taken as an average of top and bottom)  
 All windows are in upper wall material, there minimum lower wall height must be 1m even if upper and lower wall materials are the same.

**Input:**

Openings:		Notes:
door width, $d_w$ =	0.8 m	<i>max: 0.8m</i>
door height, $d_h$ =	2.3 m	
door area =	1.84 m <sup>2</sup>	
window 1 height, $w1_h$ =	0.75 m	<i>0.5m max</i>
window 1 width, $w1_w$ =	0.5 m	
window 1 area =	0.375 m <sup>2</sup>	
window 2 height, $w2_h$ =	0.75 m	
window 2 width, $w2_w$ =	0.5 m	<i>0.5m max</i>
window 2 area =	0.375 m <sup>2</sup>	

Longitudinal (long) walls:		Notes:
wall length (external) =	6.4 m	<i>6.4m max</i>
wall length (CL-CL), $l$ =	6.4	
number of doors =	1	
# of window type 1 =	2	
# of window type 2 =	1	

Transverse (short) walls:		Notes:
length (external) =	3.9 m	<i>3.9m max</i>
transverse (short) wall length (CL-CL), $w$ =	3.9	

Illustrative example of the wall parameters included in the cost estimating model

**ROOF - base information**

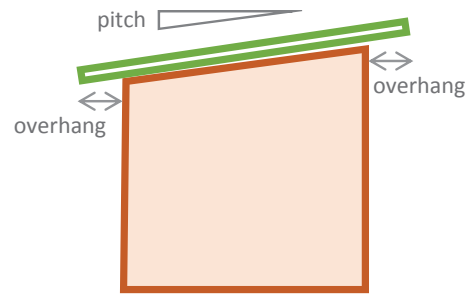
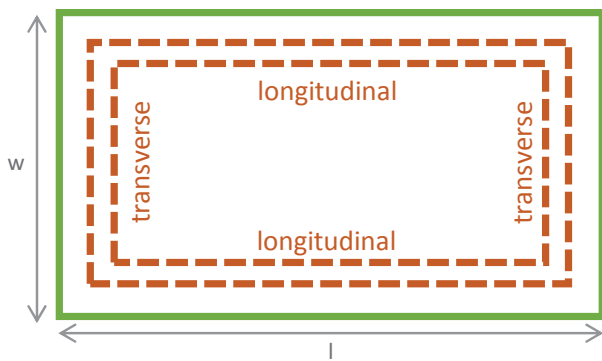

Overhang measure horizontally from building edge

- overhang (to all sides) = 0.9 m
- pitch = 5 deg
- roof width, w = 4.82 m
- roof length, l = 7.3 m
- roof area = 35.17 m<sup>2</sup>

Notes:  
 recommend 0.9m, min. 0.4m  
 min 5deg

Roof fixings:  
 (Taken as a lump sum average from agency BOQs)

Cost	CO2
1500 PKR	0 kg

Roof covering:

- plastic sheet thickness = 0.002 m
- chicks thickness = 0.002 m

Material	Area	Quantity		Cost	CO2
Plastic	35.2 m <sup>2</sup>	0.07 m <sup>3</sup>	62 kg	876 PKR	162 kg
Chicks	35.2 m <sup>2</sup>	0.07 m <sup>3</sup>	21 kg	1609 PKR	8.4 kg

Illustrative example of the roof parameters included in the cost estimating model



# Notes sheet

Print this page before you start the following process. Note down your results on the page.

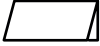

<b>Project name</b>	<b>Budget</b>
<b>Date</b>	<b>Your name</b>

What wall type did you choose?



  
Compatible Roof Types



**WALL TYPE**

  
Compatible Foundation Types



   
Bamboo Timber



**LOH KAT**

   
Loh Kat (Basic) Loh Kat (Improved)



   
Bamboo Timber



**LAYERED MUD**

   
Mud / Adobe Burnt Brick



    
Bamboo Timber Steel



**ADOBE**

   
Mud / Adobe Burnt Brick



    
Bamboo Timber Steel

**BURNT BRICK**

   
Burnt Brick Concrete

    
Bamboo Timber Steel

**CONCRETE BLOCK**

   
Burnt Brick Concrete

Notes

---



---



---



---



---



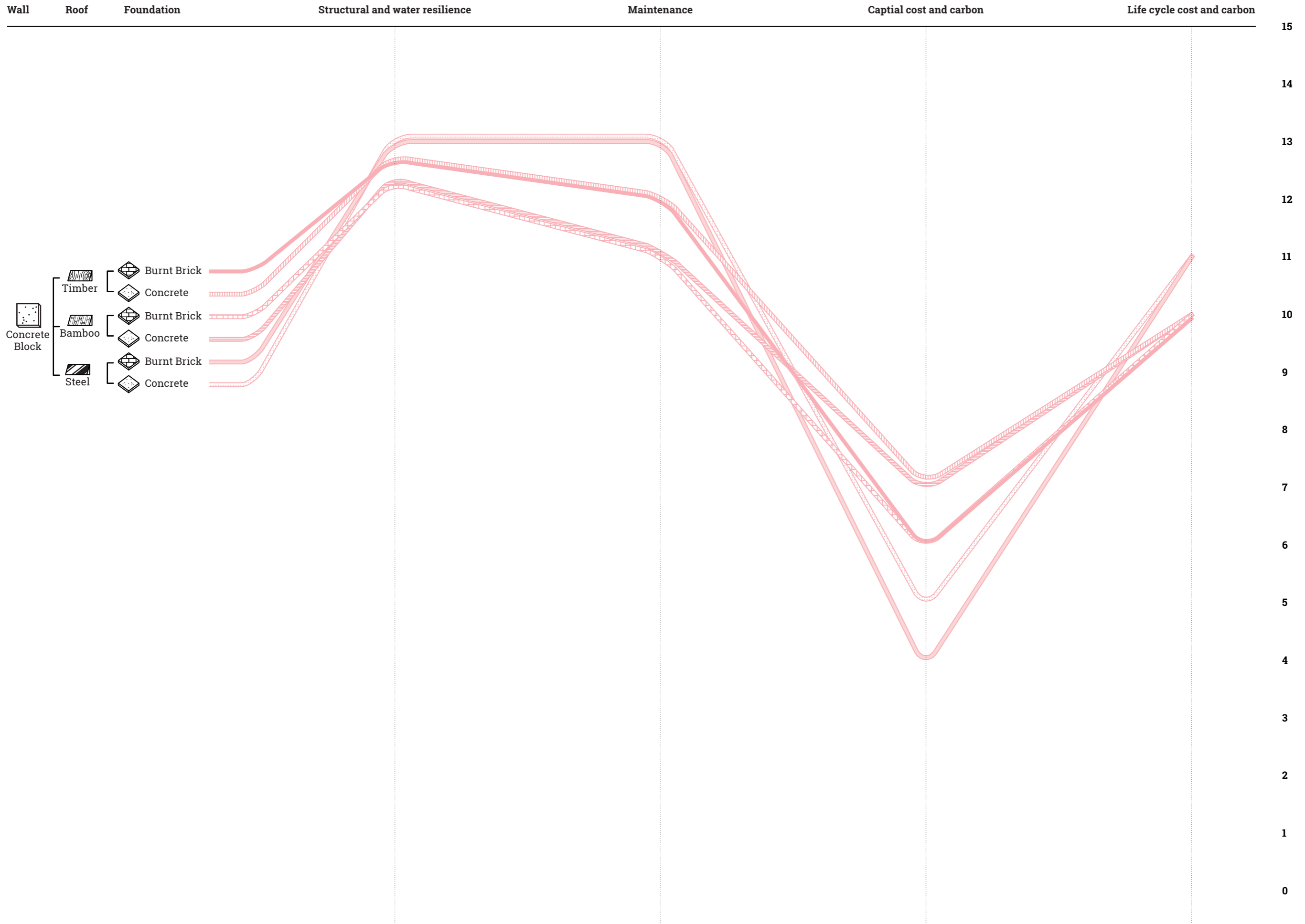

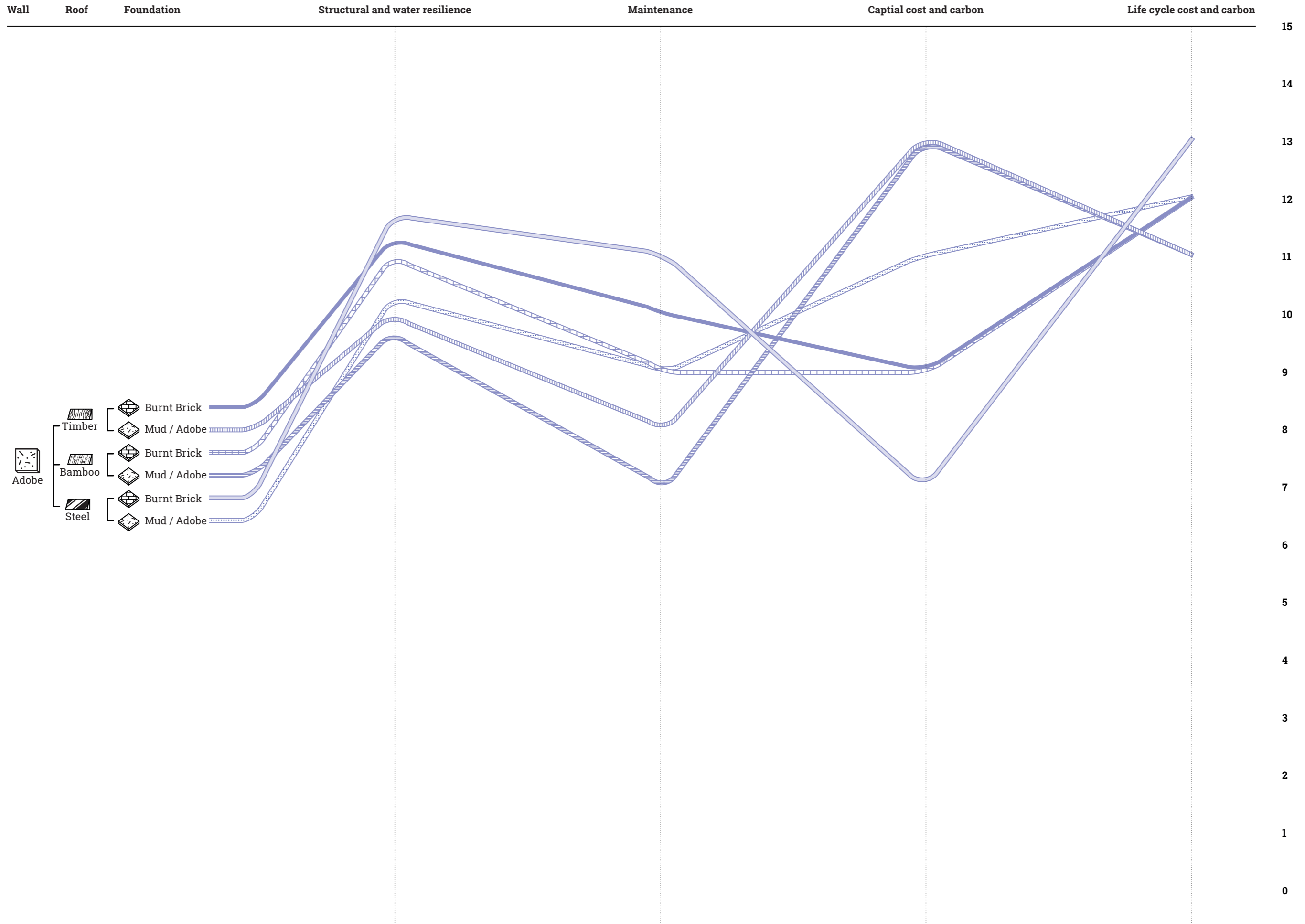

Wall      Roof      Foundation      Structural and water resilience      Maintenance      Captial cost and carbon      Life cycle cost and carbon

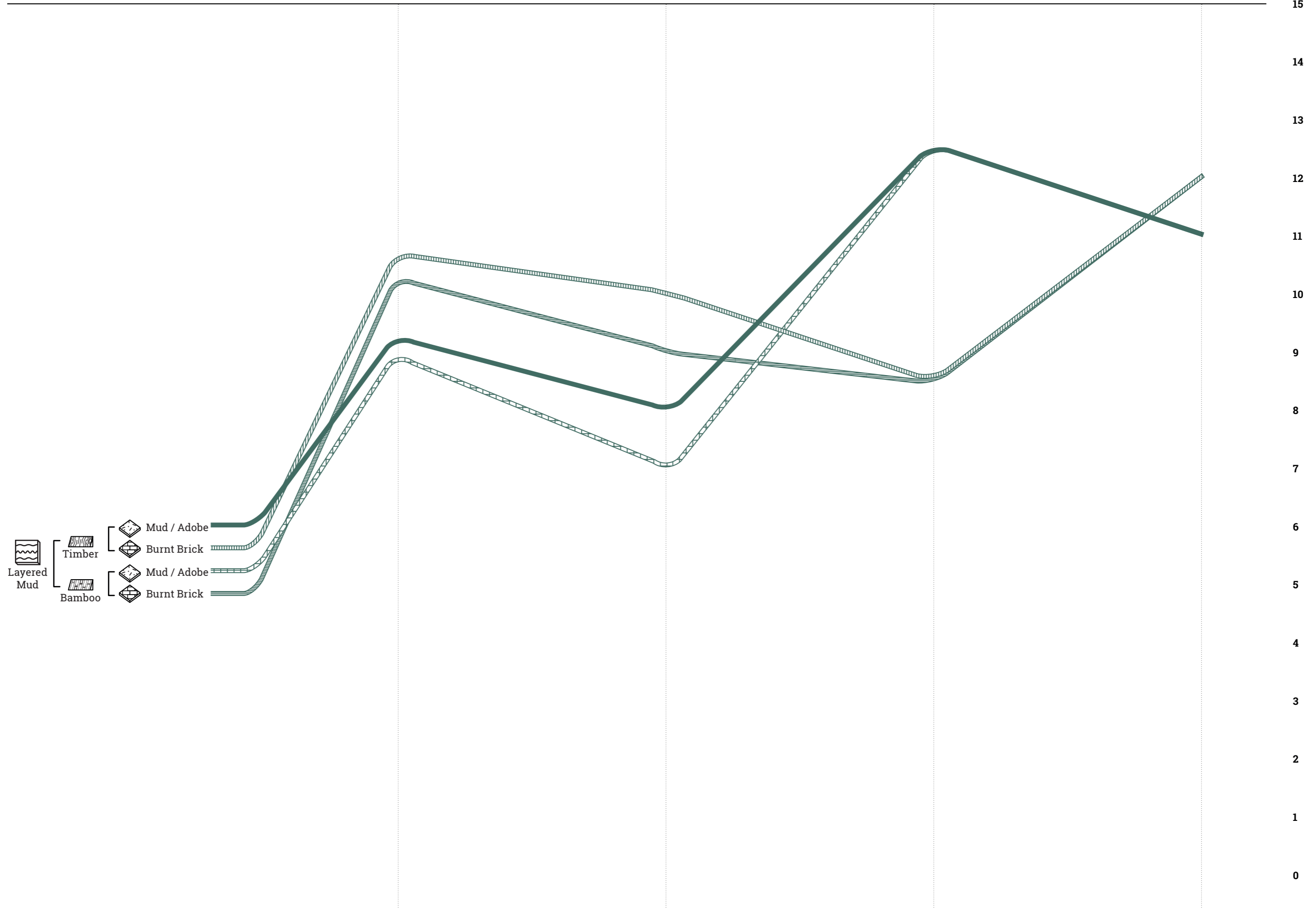

Wall      Roof      Foundation      Structural and water resilience      Maintenance      Captial cost and carbon      Life cycle cost and carbon

15  
14  
13  
12  
11  
10  
9  
8  
7  
6  
5  
4  
3  
2  
1  
0

