

REDUCING HOUSING VULNERABILITY



DISASTER RISK REDUCTION
AND PREPAREDNESS



TRAINING MATERIAL



*Reducing housing vulnerability to floods.
General concepts and technical solutions explanations.*

*A practical example :
The NRCS/IFRC shelter project in Kogi state.*

Under the auspices of Unesco Chair :









This document aim at being a tool to help project resource personal to give appropriate technical answer to “clients” (individual or institution) in the field of the building sector. It can be used for rural housing improvement or for public building.

This document doesn't aim to give only technical solutions to particular problems but to help an understanding of existing situation and give direction to improve it, this according to each specific context.

To be able to give an adequate answer to a specific request, it is essential to have a good understanding of the demand and a good analyse of the context. Proposed solutions included in this document are relevant for contexts similar to villages Mozum-Ose, Ohasi and Odugwu, in Kogi State ; Nigeria.

Symbols

FLOOD RECURRENCE In accordance of distance between communities and rivers	=	red page : illustration of a problem
 BUILD A FOUNDATION	=	green page : illustration of a potential solution

	=		=	Moderate flood
	=		=	High flood
	=		=	Very high flood

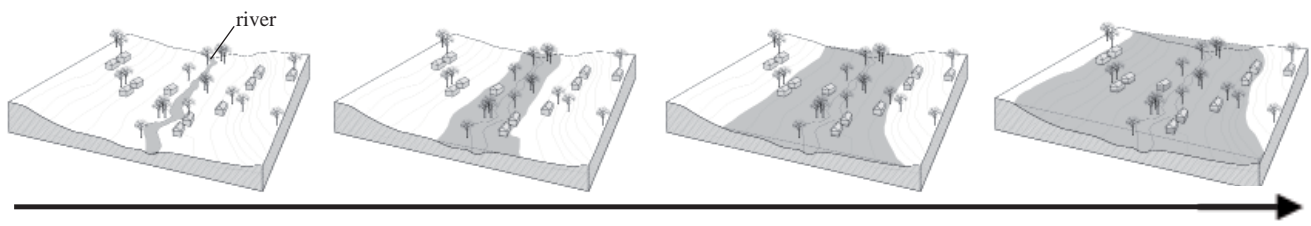

Rising waters of the river > varying intensities of floods



Low cost solution about labor → Expensive solution about labor



Low cost solution about money → Expensive solution about money

TABLE OF CONTENTS

Notification	5
General concepts	8
Risk reduction for all flood areas	12
Problem : lack of stability	12
Solution : build a foundation	13
Risk reduction for moderate floods	14
Problem : the base of the wall soaks water / « destructive furrow »	14
Solutions : to control erosion / to stabilise	15
Solution option 1	16
Solution option 2	17
Solution option 3	18
Solution option 4	19
Solution option 5	20
Problem : water rising up due to capillarity	21
General concept solution : avoid the risk of water raising	22
Solution option 1 : plastic barrier	22
Solution option 2 : cement mortar barrier	23
Risk reduction for high floods	24
Problem : erosion of structure, wich support the roof	24
Improve secondary structure life expectation :		
Step 1 : secondary structure should be braced	25
Step 2 : protect the base of the wooden pole	26
Other construction improvement	27
Problem : wind will take off the roof	27
Solution : roof fixing	28
Problem : a not correct connection can cause damage	29
Solution : insert a piece of wood to not cut the top of the wall	30
Problem : erosion of top of the walls	31
Solution : resistant material on top of the walls	32
Problem : sheets blown off by the wind	33
Solution : respect order of sheets pose	34

FLOOD RECURRENCE

In accordance of distance between communities and rivers

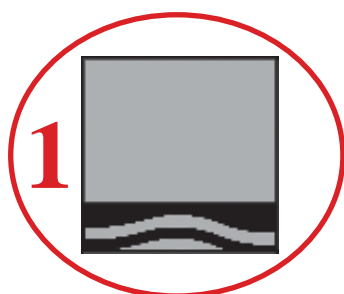
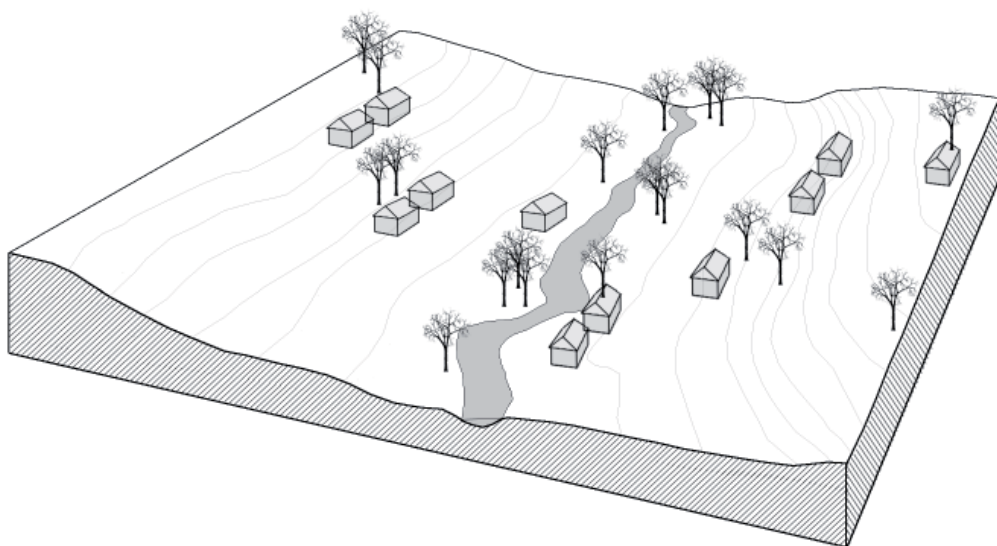
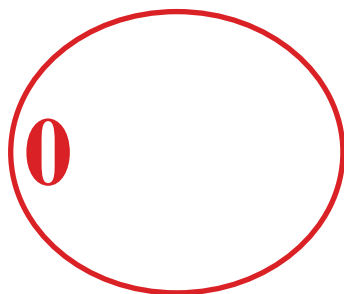

Moderate flood

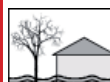
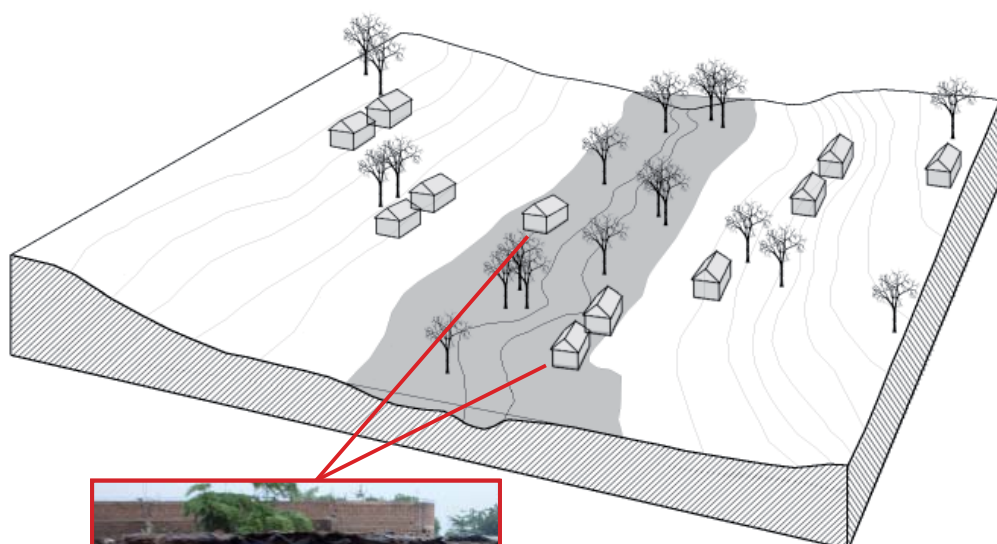

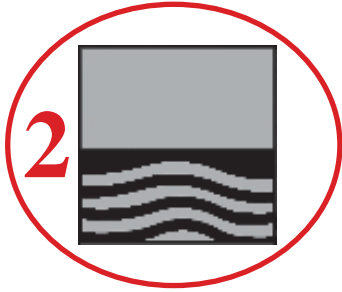

High flood

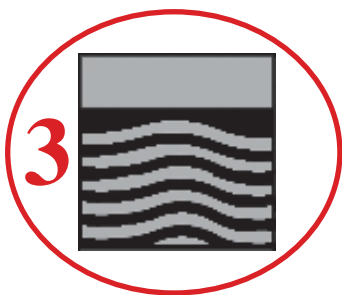
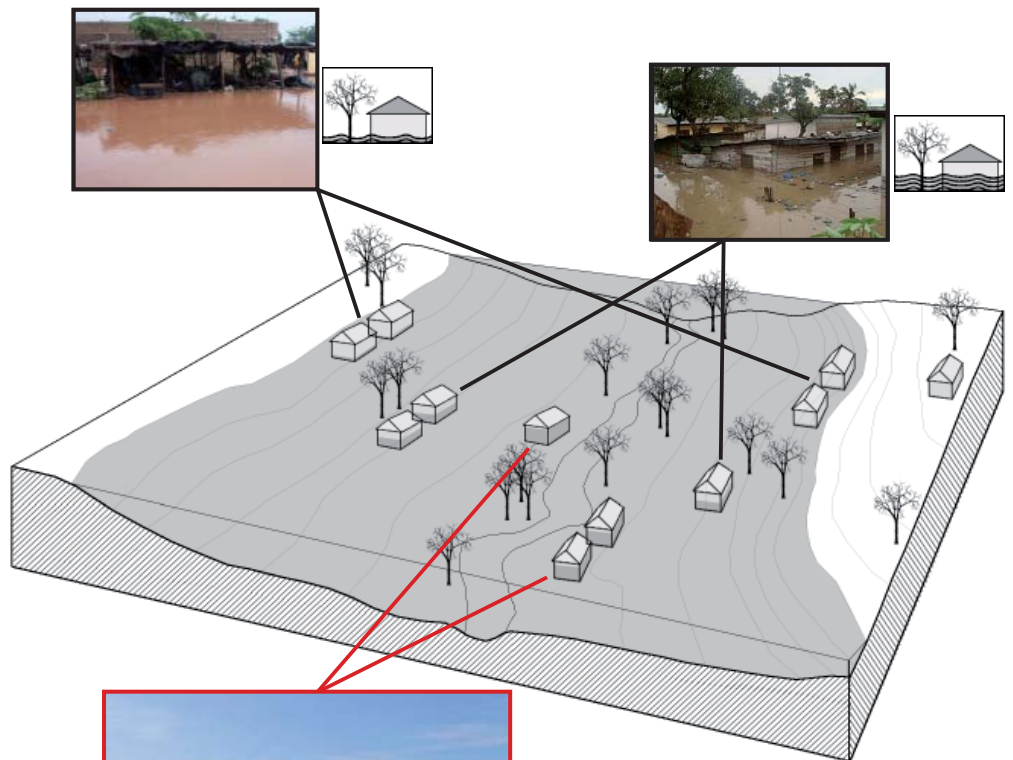
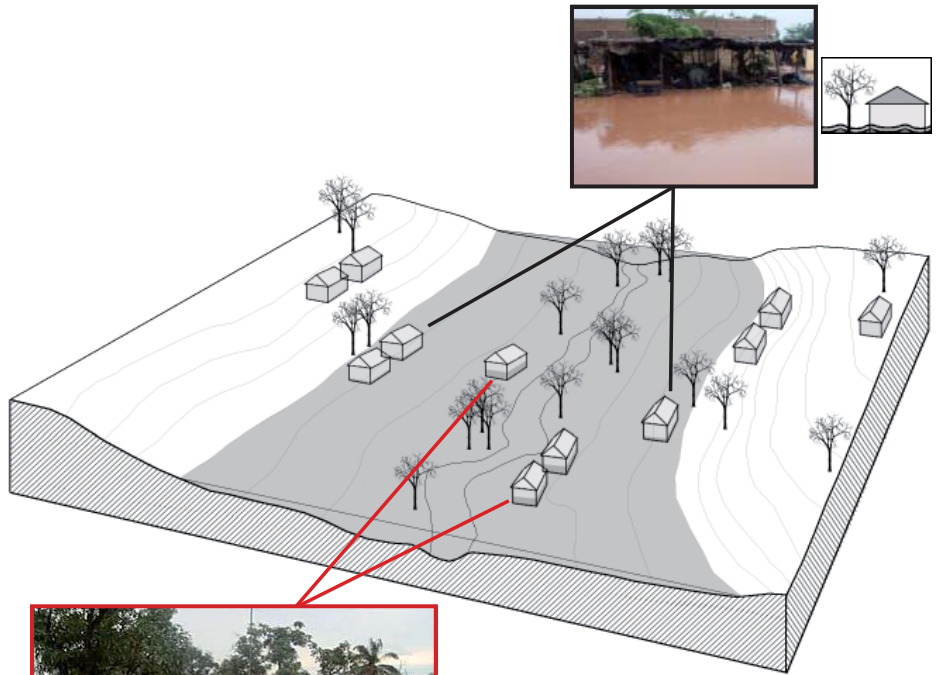

Very high flood





Very high flood

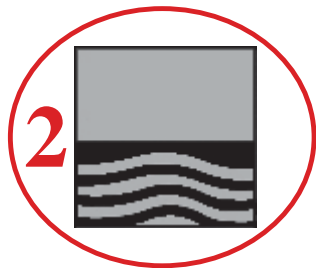
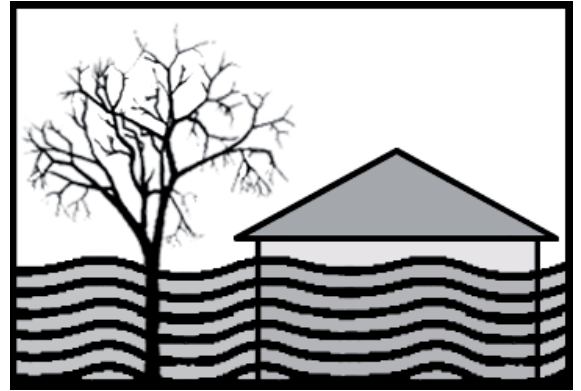

High flood

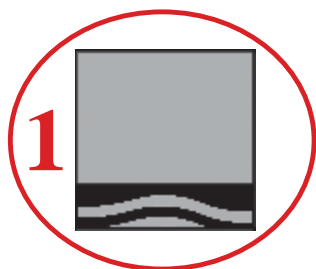
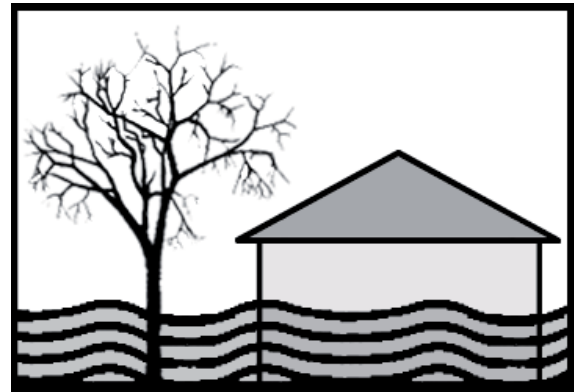

Moderate flood



IT WILL HAPPEN AGAIN !!!!!

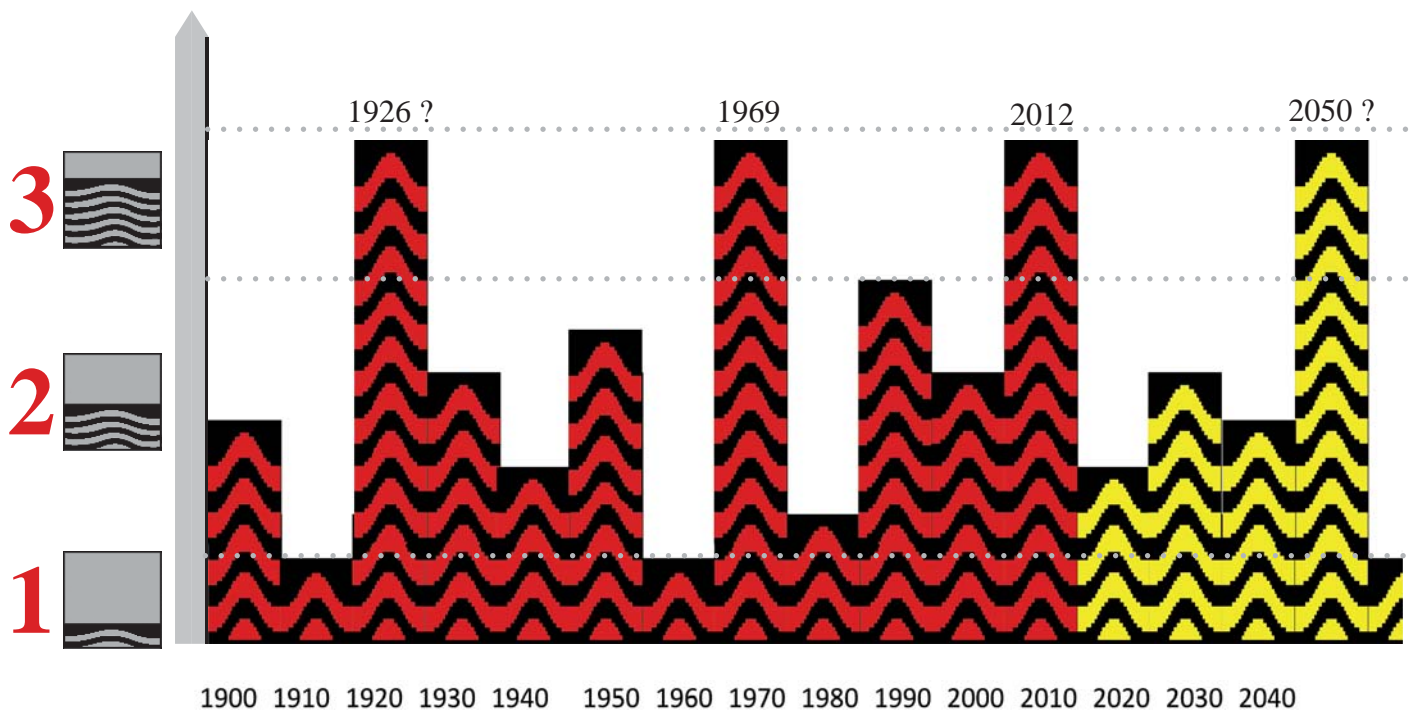

moderate floods occur every year,
high floods occur quite often,
very high floods occur once in a while, like in 2012,
and will probably occur again...



RISK REDUCTION FOR ALL FLOOD AREAS



Collapsed house, due to a lack of stability :
houses are built without a foundation



BUILD A FOUNDATION



1



RISK REDUCTION FOR MODERATE FLOODS

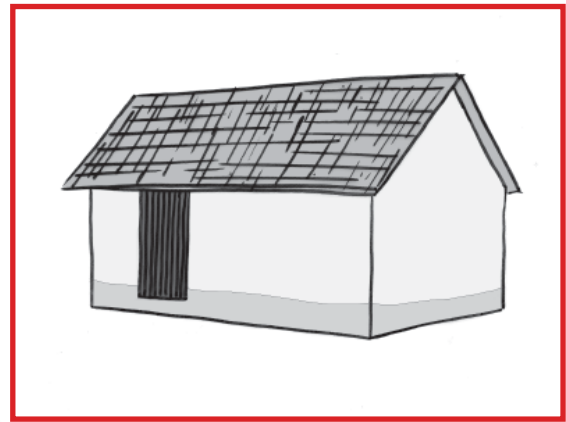
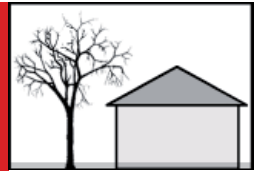

The base of the wall soaks water

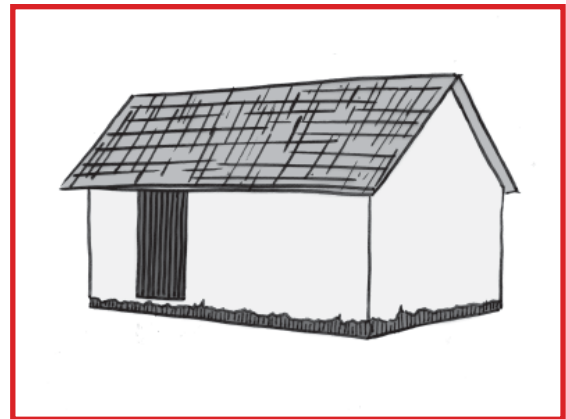

A "destructive furrow" appears : water gnaws the base of the wall





PROTECT THE BASE OF THE WALLS

GENERAL PRINCIPLE :



Mud in contact with water will be washed away

To control erosion

or

To stabilise

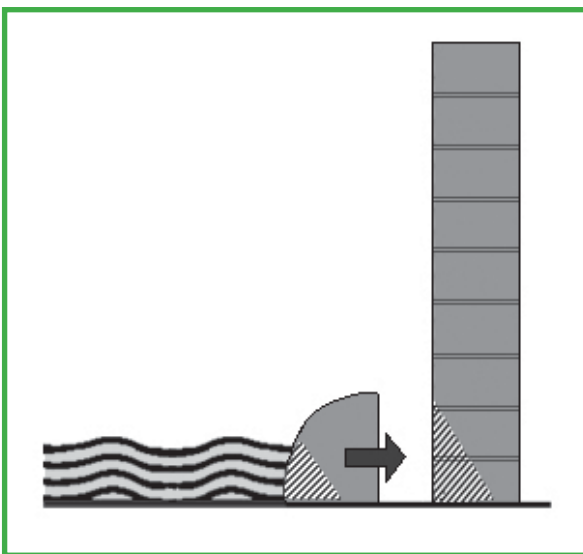

protective mass

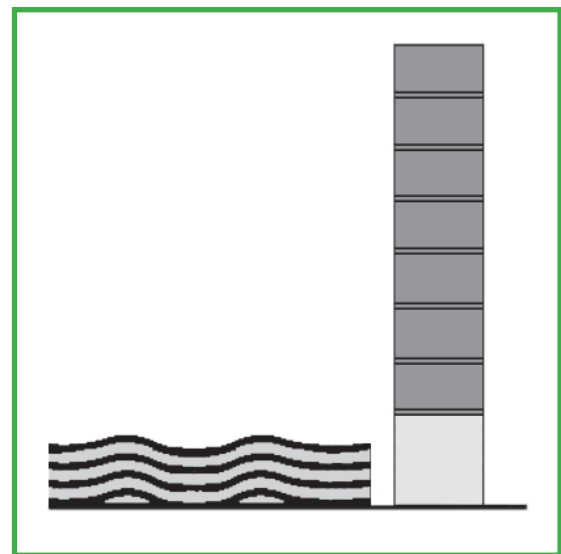

water-resistant material



PROTECT THE BASE OF THE WALLS

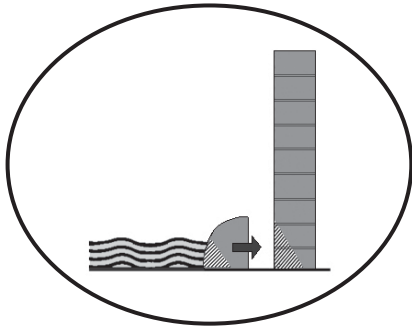

Low cost / Labour intensive



Protective mass added around the house

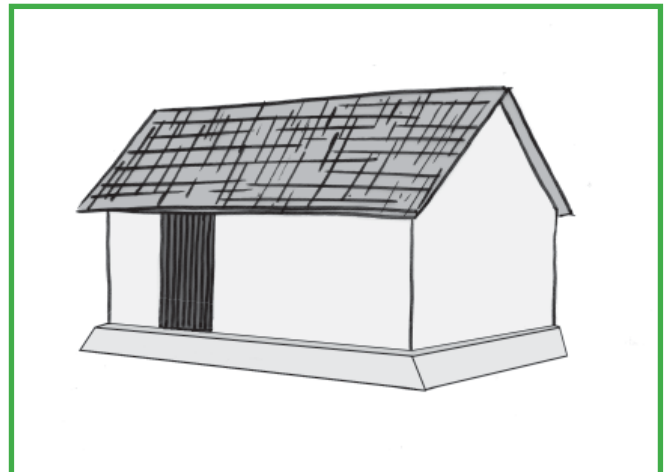



PROTECT THE BASE OF THE WALLS

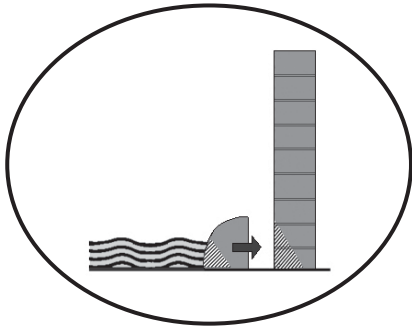

Low cost / Labour intensive

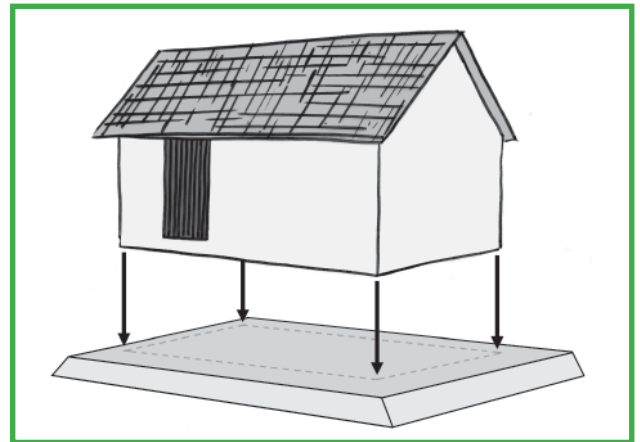
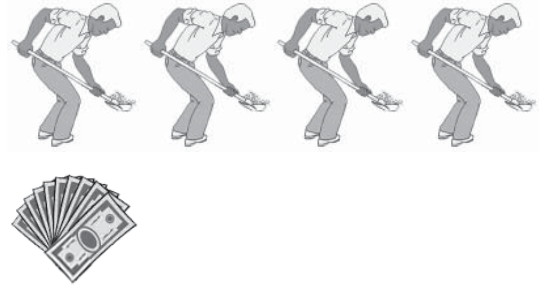

House built above a protective mass (platform)

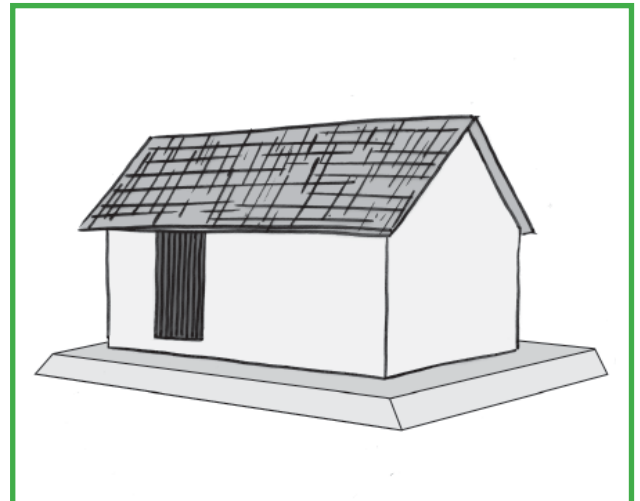



PROTECT THE BASE OF THE WALLS

Moderate to high cost / according to raw material availability

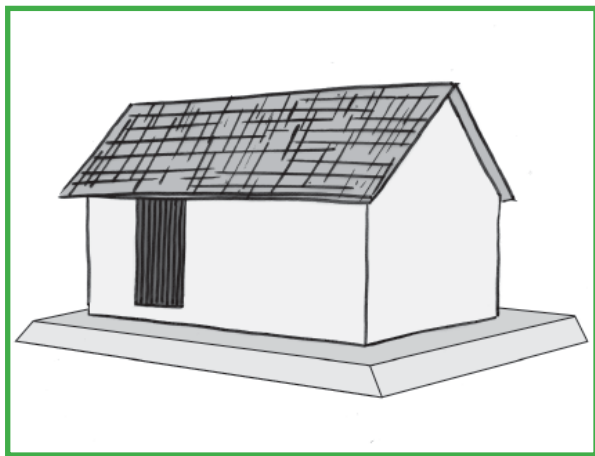
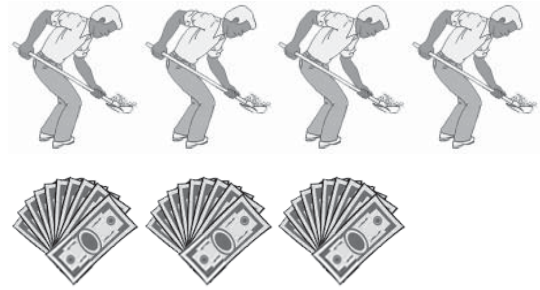
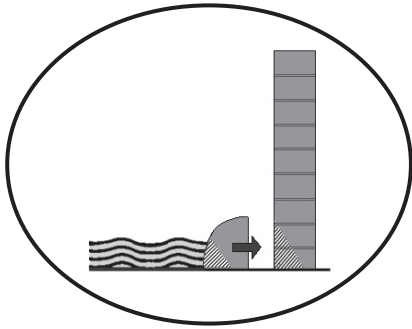

Consolidation of the protective mass by a water-resistant material





PROTECT THE BASE OF THE WALLS

Moderate to high cost / according to raw material availability

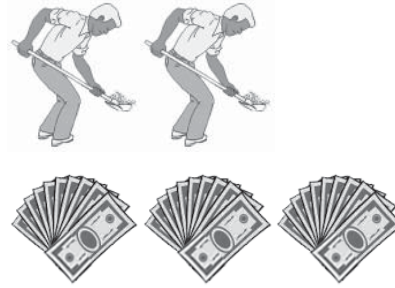
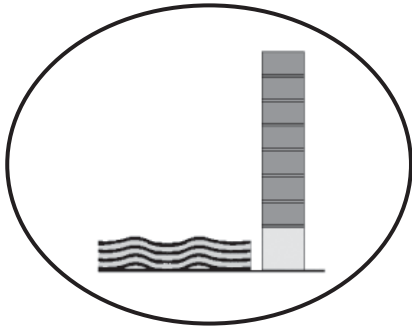

First courses of the wall built with water-resistant material : cement blocks





PROTECT THE BASE OF THE WALLS

Moderate to high cost / according to raw material availability

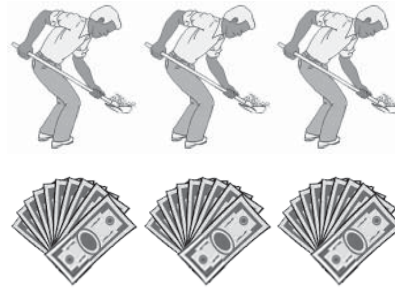
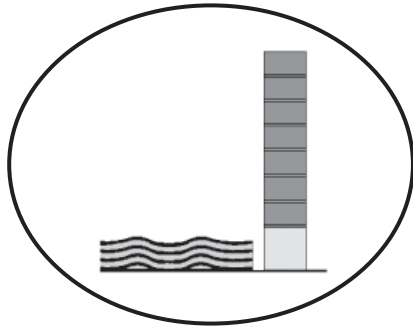

Basement house built with water-resistant material : stones / cement mortar finition



1



RISK REDUCTION FOR MODERATE FLOODS



Water rising up due to capillary



In spite of a water-resistant basement, water rises up to the earth walls



...and weakens the house



AVOID THE RISK OF WATER RAISING

GENERAL PRINCIPLE :



Barrier against water uprising : plastic



AVOID THE RISK OF WATER RAISING



Barrier against water uprising : cement mortar (350kg/m³)

2



RISK REDUCTION FOR HIGH FLOODS



Create a secondary structure that support the roof in case the walls collapse could be the solution to secure the roof...
but take care of the life expectation of this secondary structure !!!



Erosion of structure damaged by flood,
risk for the house to collapse



SECURE THE ROOF IN CASE THE WALLS COLLAPSE



Improve secondary structure life expectation to not bend :
secondary structure should be braced !!!

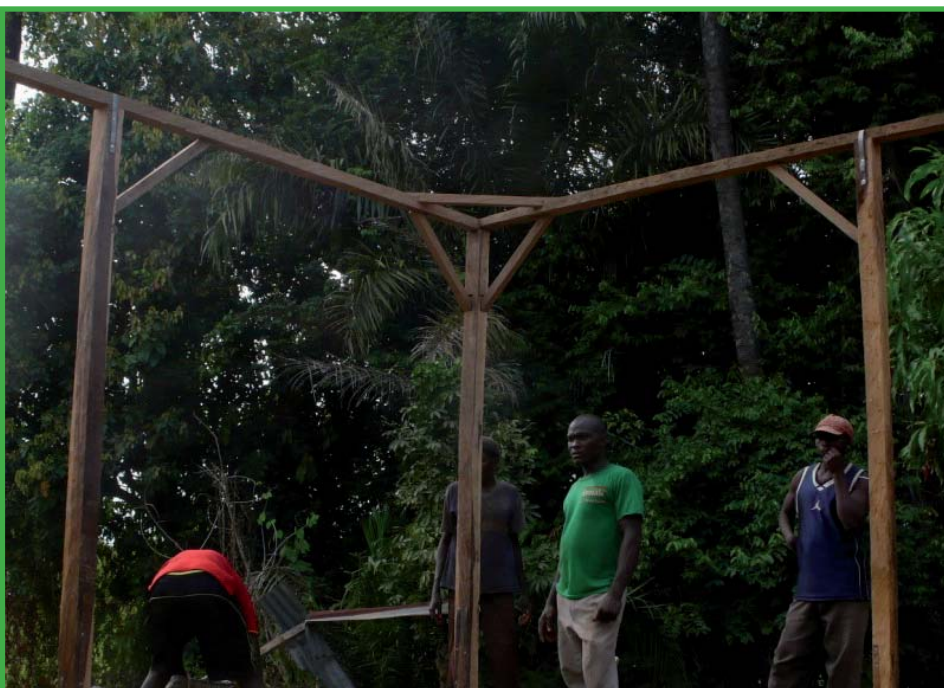



SECURE THE ROOF IN CASE THE WALLS COLLAPSE



Improve secondary structure life expectation :
protect the base of the wooden pole with water resistant material

OTHER CONSTRUCTION IMPROVEMENT

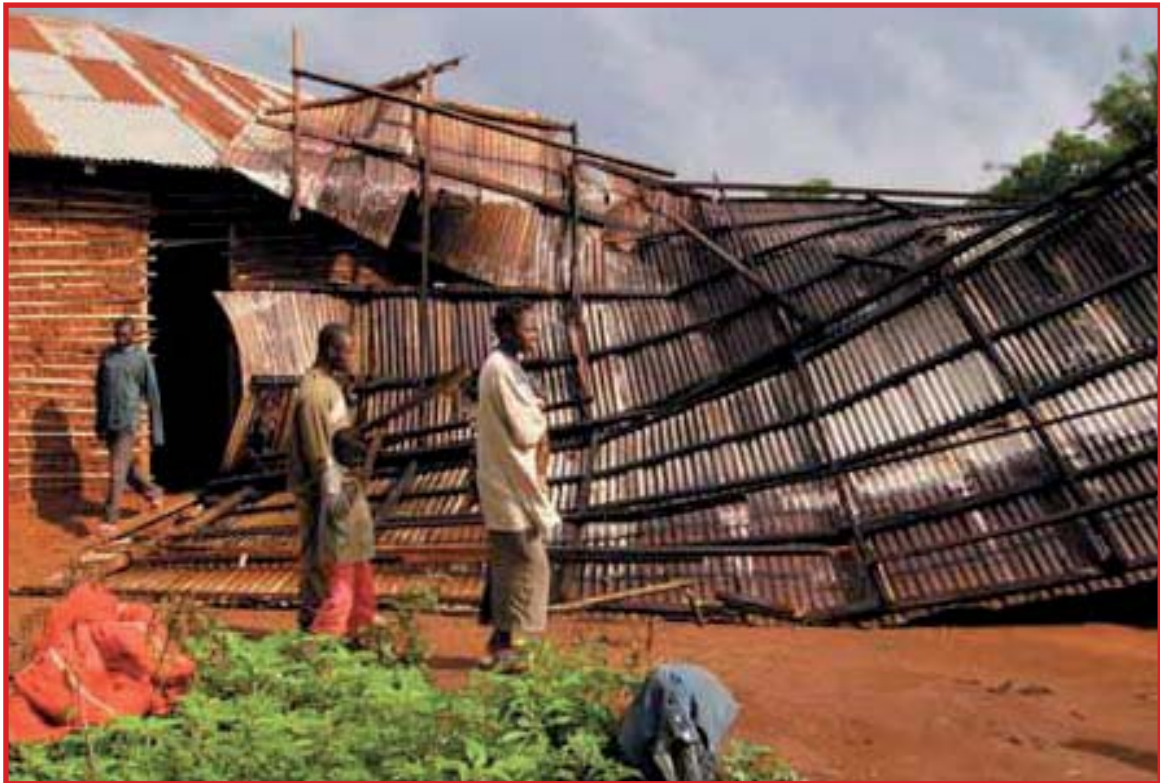

If anchorage is not properly done,
wind will take off the roof !!!



ROOF FIXING

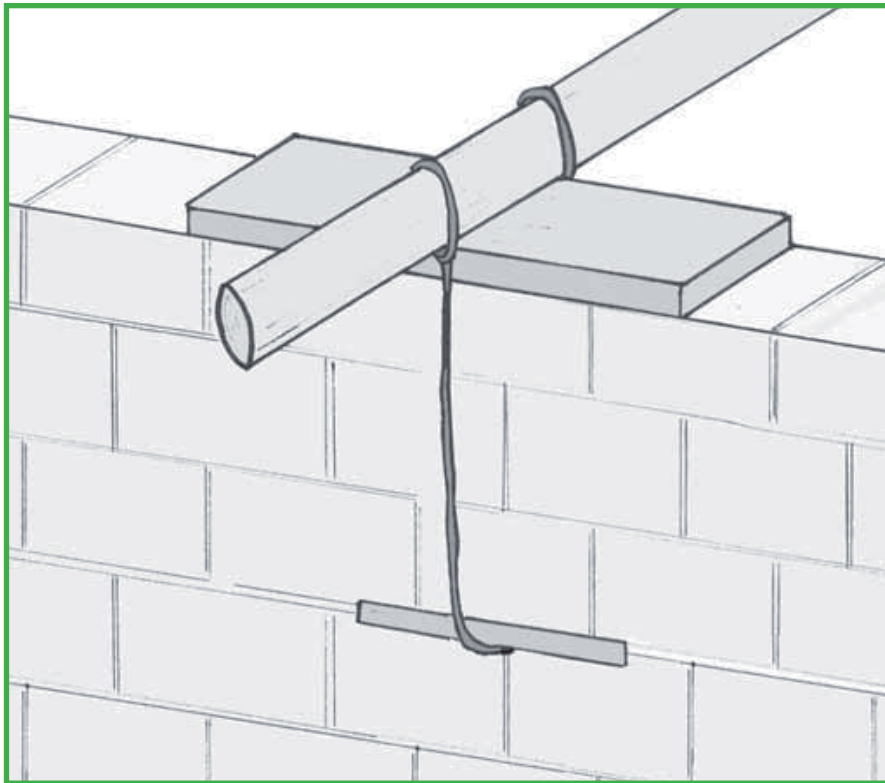

To avoid the roof to take off, it must be linked to the walls.

The connection must be done below several courses of bricks to provide sufficient weight against the wind force.

OTHER CONSTRUCTION IMPROVEMENT

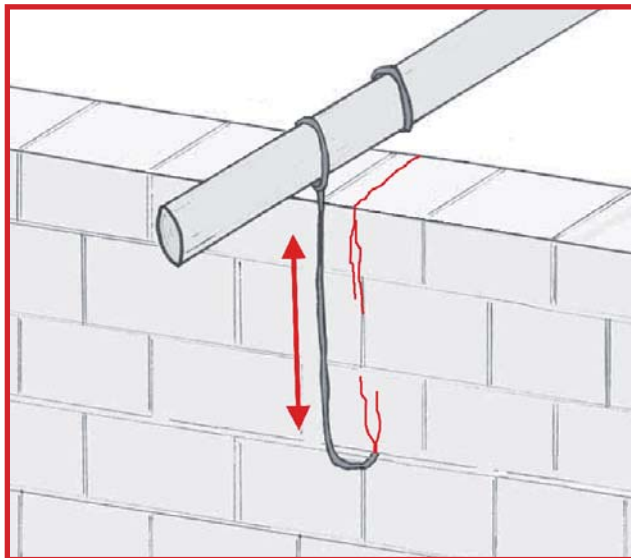

A not correct connection can cut the blocs on the top of the wall, that have to hold the roof in place.



ROOF FIXING



A piece of wood (or other material : metal, ...) must be laid between mud blocs and wire to prevent the cut of the blocs themselves.

OTHER CONSTRUCTION IMPROVEMENT

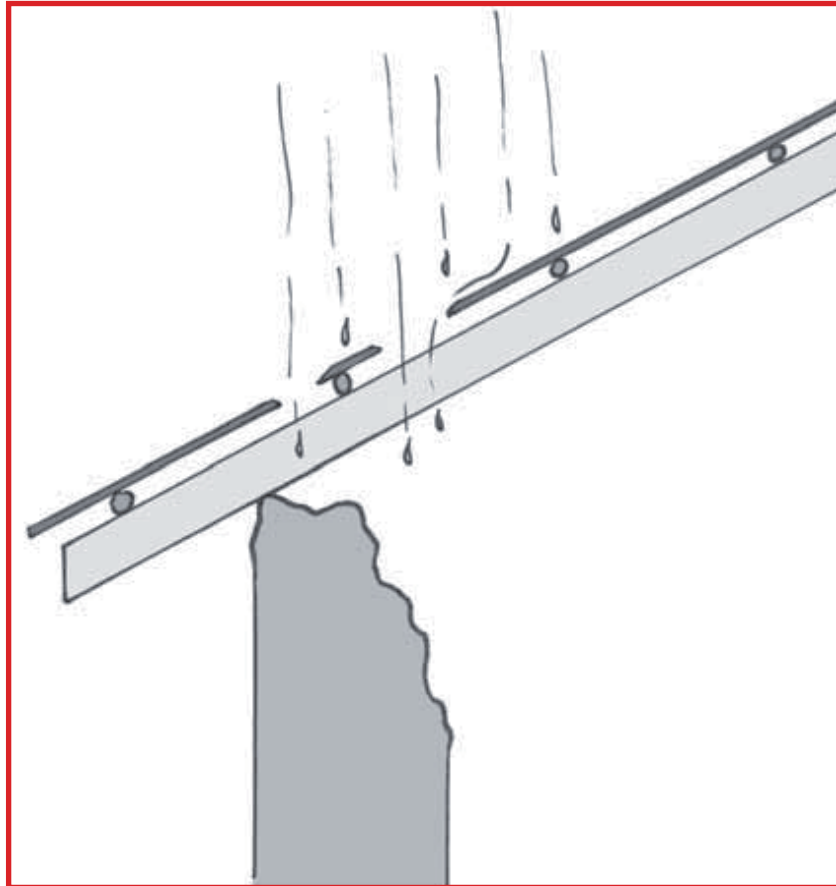

Erosion of top of the walls



RESISTANT TOP OF THE WALLS

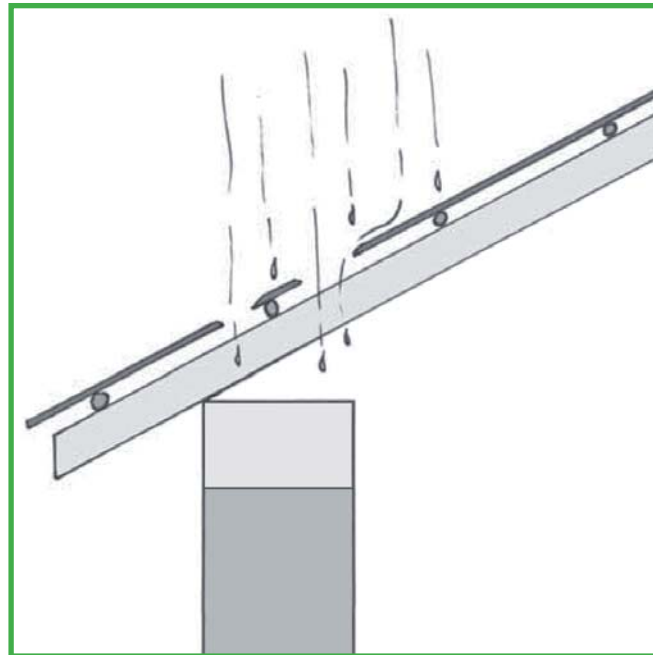

Use water resistant material on top of the walls :

- sand / cement
- blocs
- mortar...



OTHER CONSTRUCTION IMPROVEMENT

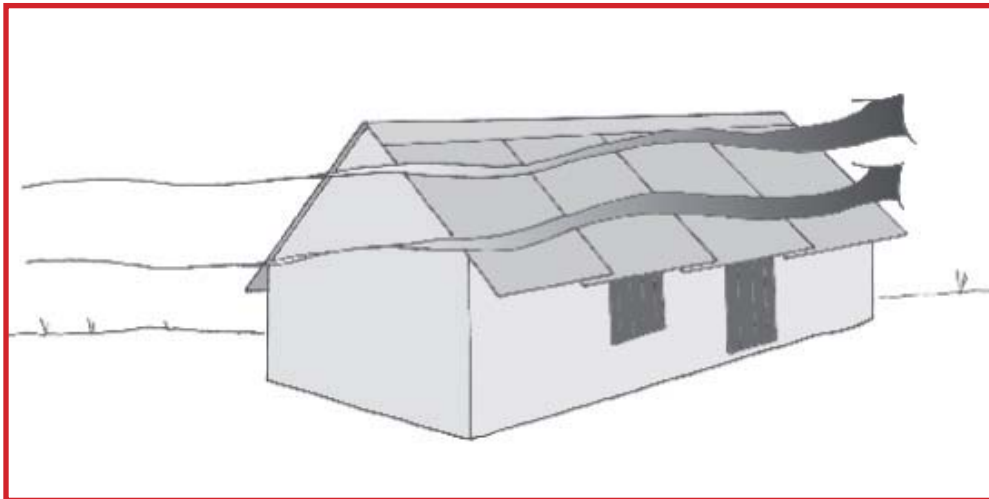

Sheets blown off by the wind



INSTALLATION OF SHEETS ACCORDING TO THE WIND DIRECTION

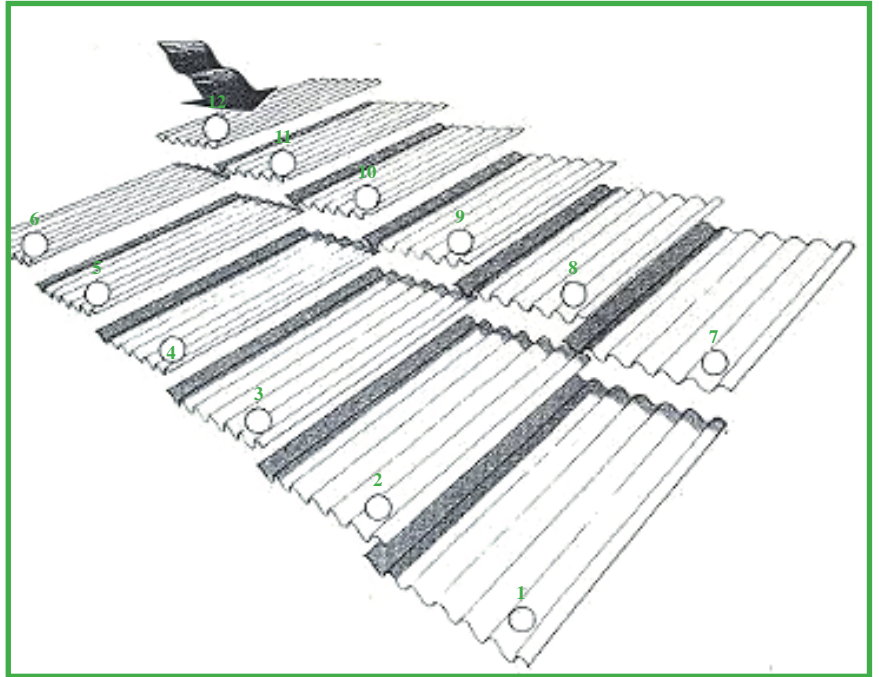
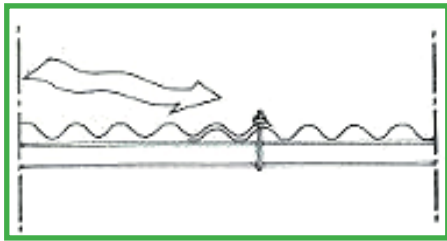

Respect order of sheets pose
to prevent wind from entering through the sheets
and blow off the roof

