

# Fanorenana trano fonenana afaka miatrika ny rivotra sy ny ranobe

**“Ny trano no mafy orina, ny fianakaviana ho voaaro amin`ny voina”**

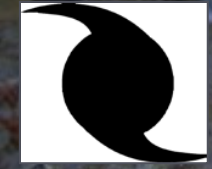

**A**siana kiho ny rafitra eo amin'ny tafo

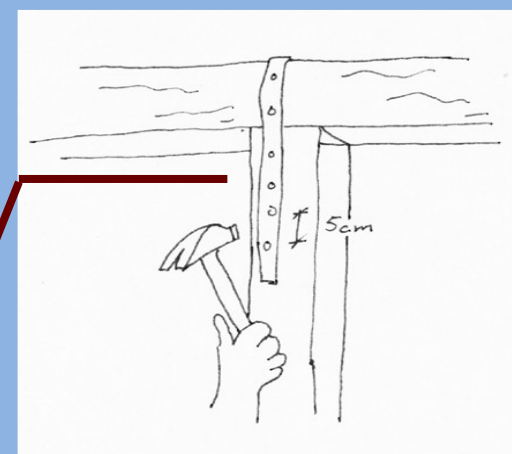
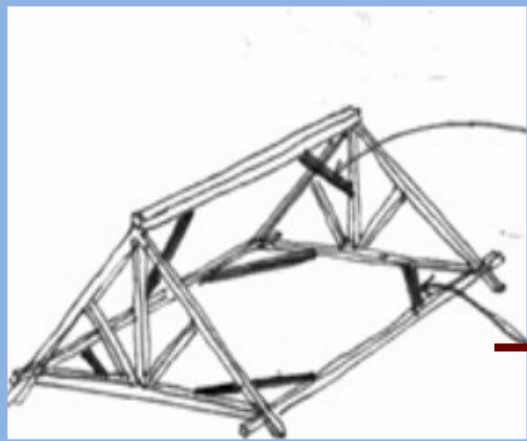

**H**amafisina amin'ny metaly ny fifampitohizana mba hampihena ny fiantraikan'ny rivotra amin'ny tafo

**A**siana tohana ny panne "cale-panne"

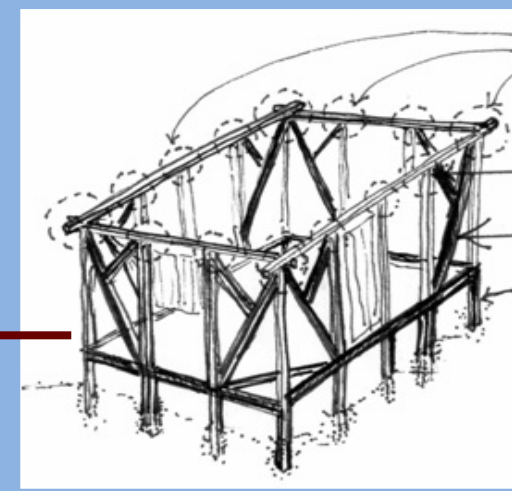
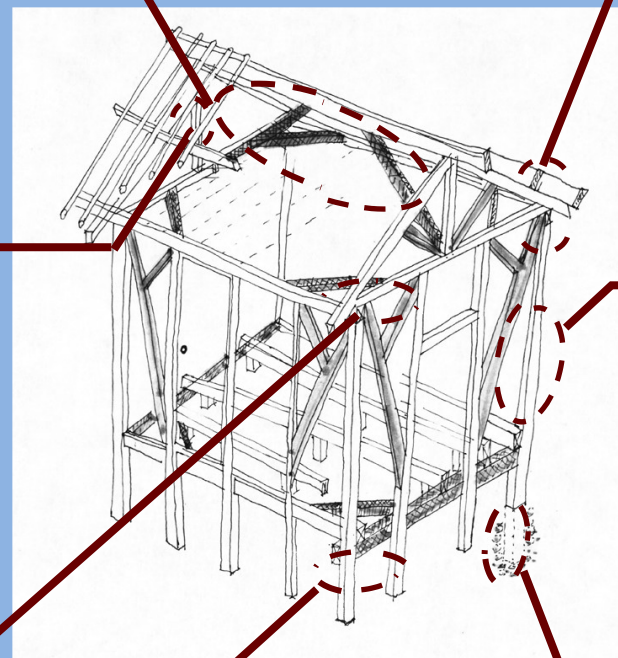
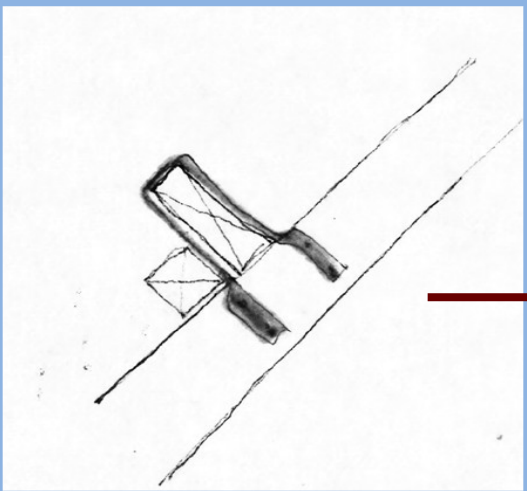

**A**siana kiho ny zoron-drindrina

**A**siana kiho ny "cadre-chainage" ambony sy ambany

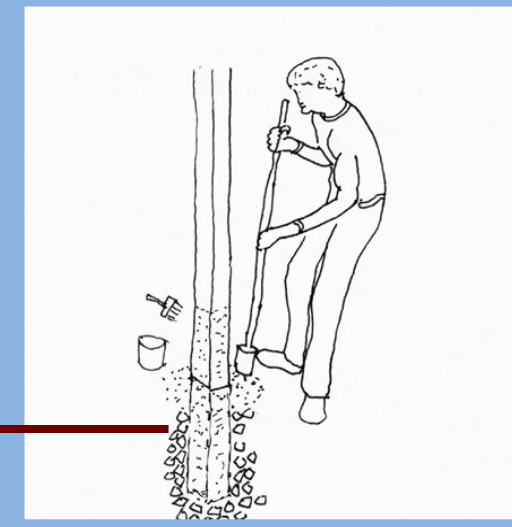
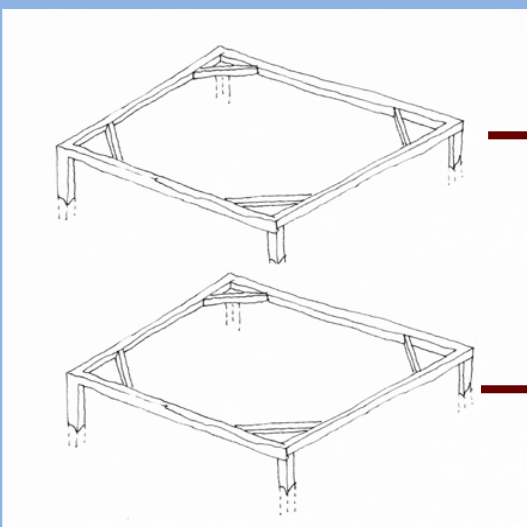

**M**andavaka 75 cm farafahakeliny Fenoina vato kely hatramin'ny 10 cm eo ary totoina mba ho mafy



**A**rovy amin'ny "huile de vidange" na loko ny andrintrano mba hateza raha toa ka tsy kakazo teza" no ampiasaina



**K**ojao sy ovao ara-potoana ireo singa amin'ny rafitra



**H**amafiso amin'ny fatotra tariby sy fantsika ny fifanohizana aminy rafitra rehetra araka izay azo atao