

Os edifícios construídos usando materiais de construção convencionais são geralmente inacessíveis para a maioria da nossa população. Assim, alternativas, relativamente baratas, decentes e duráveis de produção local de materiais de construção vem sendo desenvolvidas e usadas em Moçambique. Dentre estes materiais inclui-se o bloco de solo-cimento. Parece-nos que a ausência de manuais simples e ilustrados esta a influenciar o processo de uma utilização cada vez mais abrangente de materiais de construção produzidos localmente. Por outro lado, a informação disponível é somente acessível para um número limitado de pessoas e as publicações são geralmente demasiadas complicadas para os produtores locais, comunidade usarem essa informação. Infelizmente aqueles que mais precisam tem menos acesso a informação. Foi tendo em consideração estes aspectos que o Ministério das Obras Públicas e Habitação, através das Direcções Nacionais de Edificações e Habitação & Urbanismo, elaborou o presente manual que é o primeiro duma série de vários a serem elaborados. Os objectivos deste manual são:

- Resumir dados técnicos e informação proveniente de várias publicações de modo a que o usuário perceba os aspectos relacionados com a produção de bloco de solo-cimento.
- Ilustrar muita informação proveniente de vários textos em um formato mais fácil de perceber.
- Disseminar conhecimentos sobre materiais de construção alternativos através de manuais simples.

Este manual não substitui as análises científicas sobre tecnologias de construção pelo que os seus usuários deverão consultar as autoridades e/ou profissionais competentes quando se confrontarem com situações adversas.

#### Manuais publicados:

- Manual de produção de blocos de solo-cimento



REPÚBLICA DE MOÇAMBIQUE

MINISTÉRIO DAS OBRAS PÚBLICAS, HABITAÇÃO E RECURSOS HÍDRICOS

Direcção Nacional de Urbanização e Habitação

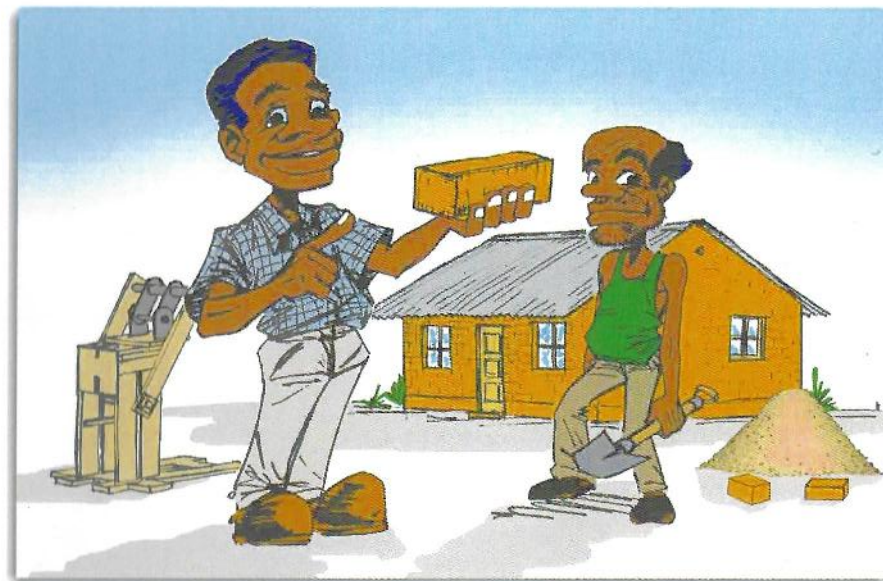

**Bhuko yakudziwissa ku canha njérua  
zinatcituwa na Matace na cimento**

Sena

**Bhuko yakudziwissa ku canha njérua  
zinatcituwa na Matace na cimento**

**Sena**

Maputo, Fevereiro de 2019

Colecção: *"A Arte do Bem-Construir"*

Vani achamuali, ine ndine  
Messir açachemerua zé Obra. Ife  
tiripano towera tifhunzicene kukanha ma  
njérua towera timangue zinhumba ninga  
zakufunzira mabuko (machicola),  
zaungume, na mataka yali nzico  
muathu.

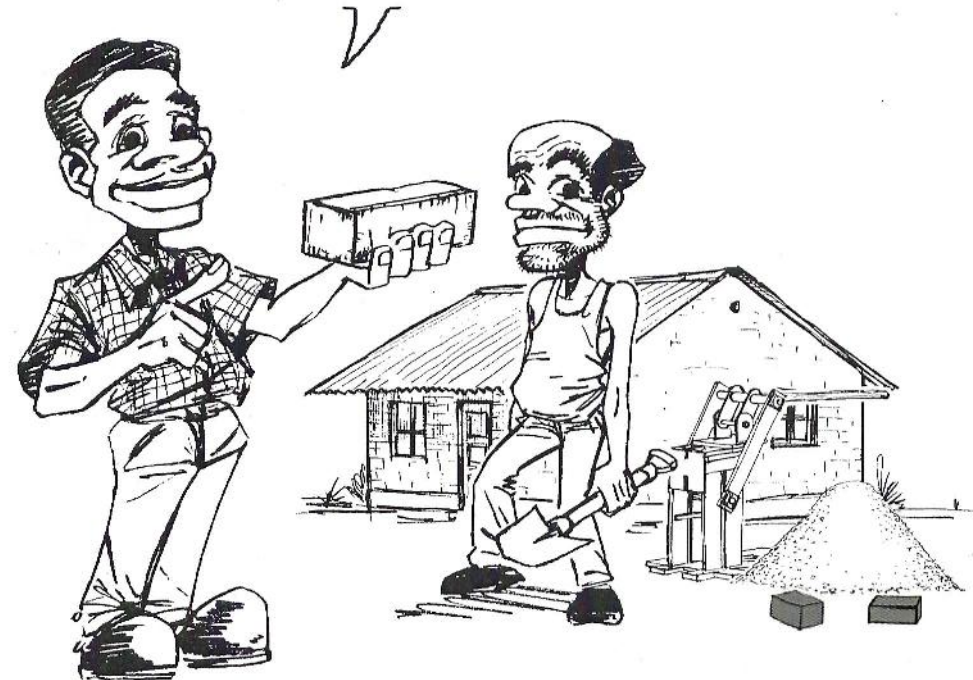

Zé Obra, ussapizua  
cuti mataka ndi chiombo  
chikulo china cenza na anthu  
towera manga pindhu ?



Madhembe a nhumba zidha  
mangua kale papiaka pya pikni  
pia 12 nduli, pissapanguissa cuti  
matakawa assebhenzessua  
maningui towera kumanga  
kumanga zinhumba.

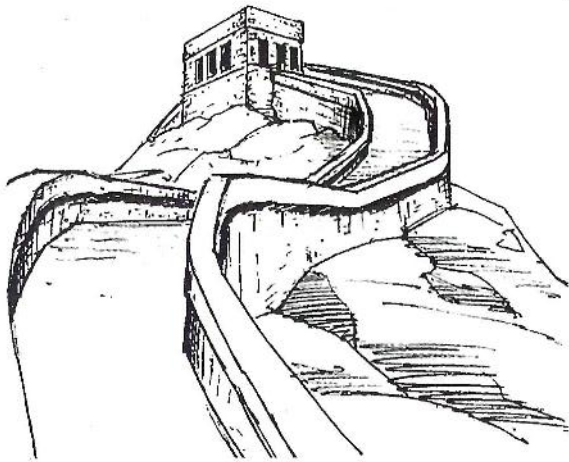

Pacupita nzindzi,  
munthu, adziwissa kakamue  
kumanga nhumba zadhidhi  
mbizi khoma.



Zé Obra,  
Mussapizua kuti.

Lero, iripo machitiro  
mazindzi akumanga na  
mataka.



Umessiri anjerua unatitika  
ndio una funica cu umba njerua  
na nataka na cemento.

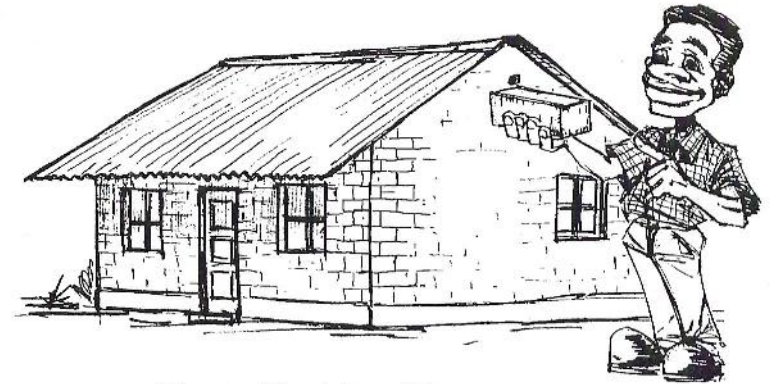

Njerua ibhozi issachitua na  
mataka mbivungassua cemento na  
madzi mbikhomerua makina.



Mataka    Cimento    Madzi    Bokhossi

=

Njerua yakumbiua na mataka na cemento

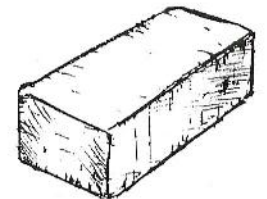

Na tinepa tinakuanissa kuona  
piombo para cumanga não zinhumba  
mbitiona makhaliro yanhumba  
zakubalika.

Nhumba  
zinakhuma pakati  
kuvimbirua.



Pakupissa

Mbikali na  
kudhambo kupissirira  
ncate muache.

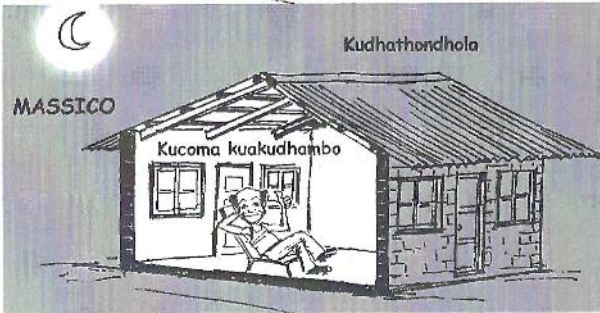

Missiri, ndipianji pinafunika  
towera chitike njerua yua mataka  
na cimento ?



Towera umba  
njerua wa mataka na  
cimento, safunica  
sankhula mataka  
yia dhidhi.

Assassankhulatani  
mataka adhidhi ?



Mataka  
akukhonda  
khala  
muadhidhi

Mbuenhe  
mataka  
adhidhi

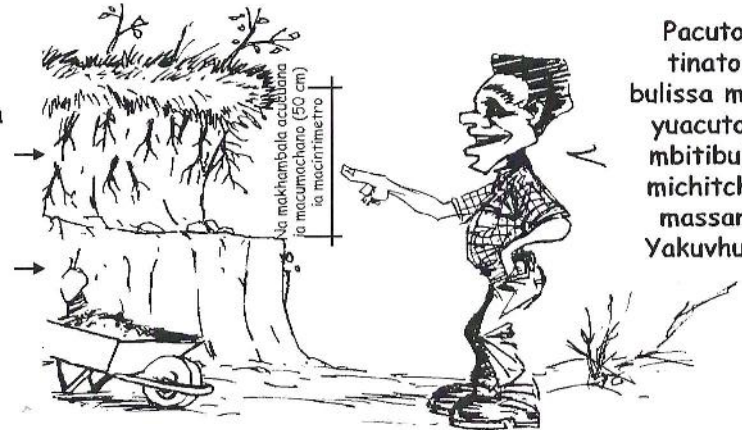

Pacutoma  
tinatoma  
bulissa mataka  
yuacutoma,  
mbitibulissa  
michitchi na  
massamba  
Yakuvhunda.

Mataka  
akukhonda  
khala  
muadhidhi

Mbuenhe  
mataka  
adhidhi

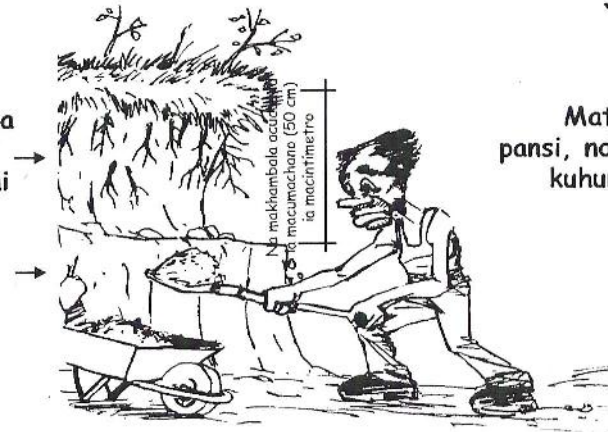

Mataka adhidhi ali  
pansi, ndio anafunika towera  
kuhumba não njerua.

Tinga umba njerua na mataka ku kukhala muadhidhi, khabhe khala na njerua akukhoma.

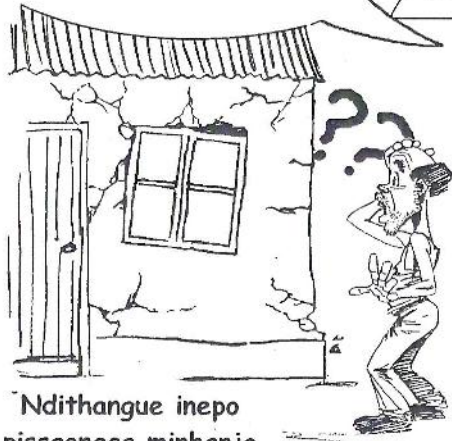
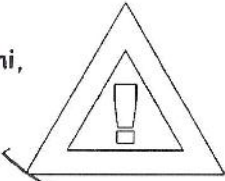

Ndithangue inepo pissaoneca minhanjo matuto ya nhumba.



Tepa mbatiendeny cu laboratório, towera ndiri cupangueny açã ssanghulua tani mataka.

Tina tipiziwe tany kuti mataka mbadhidhi peno nkhabe.

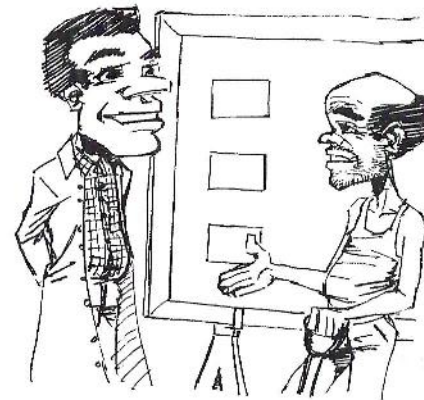
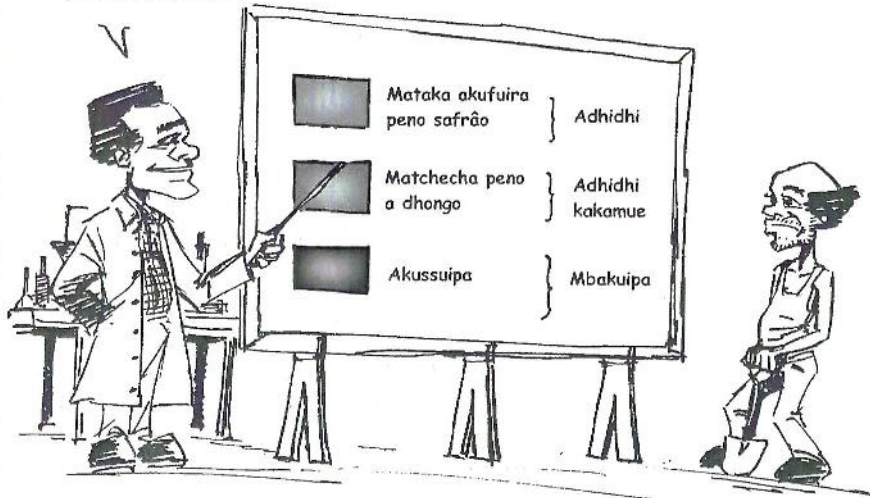

Messir ! Mataka onsene mbadhidhi towera kuhumba naô njera na cimento ?

Nkhabhe, pissafunica cuti mataka ana tchecha peno ndhongo.

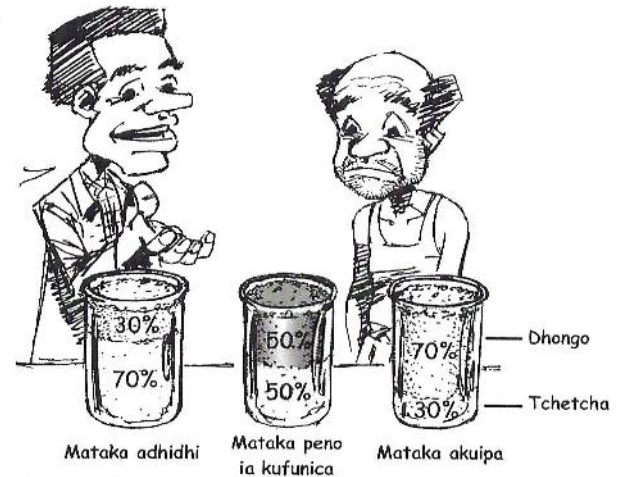

Mataka anagumanika na ndhongo izingi, nkabhe kuanississa cu umbã njerua.

Alipo mataka avunguizana na tchecha na ndhongo ndio mataka yua ndhongo.

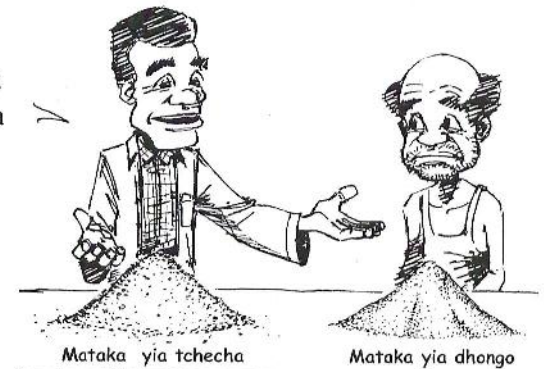

Na matchecha ia dhidhi tinavunga tchecha panghono cemento, mbuenhe na mataca dhongo tina vunga maningue cemento, na tenepo njérua inakala ya kudhura.

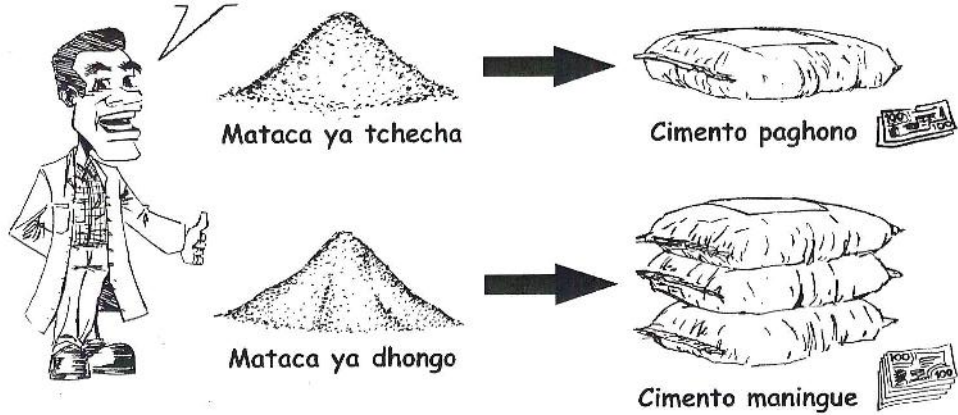

Mphapo mataca a dhongo bassache ndjanhe ?



Isafunika khala na dhongo panghono towera kuchita njérua ya kuwanga, issapedzambo kuma kuache.

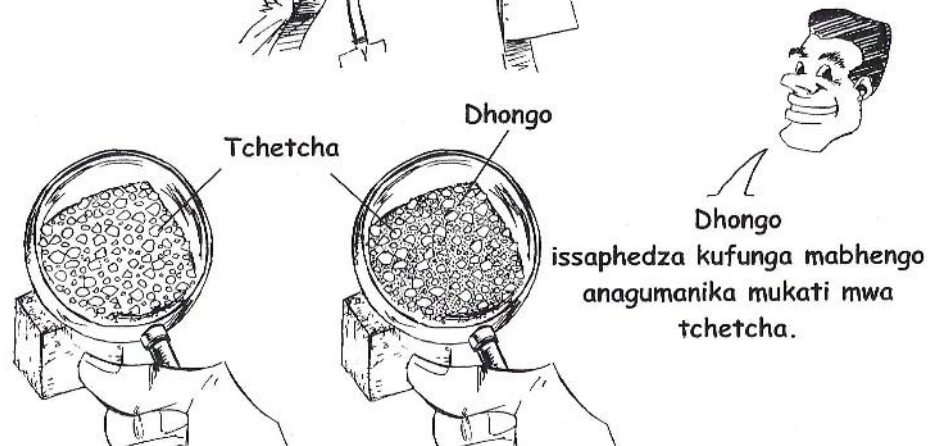

Na thangui ineyo tissafunika tii thimidze dhongo pa mataca ana tchecha izinji.

Mataka anga khala na dhongo maningui ?



Ingakhala na dhongo maningui tissafunika ti thimizire cemento towera kuhumba njérua.

Ndithangue ineyo inanessa kukanha pondho mataka anapatilira mukundo mwa bokossi, mbwenhe njérua iache nkha khala mwadhidhi.

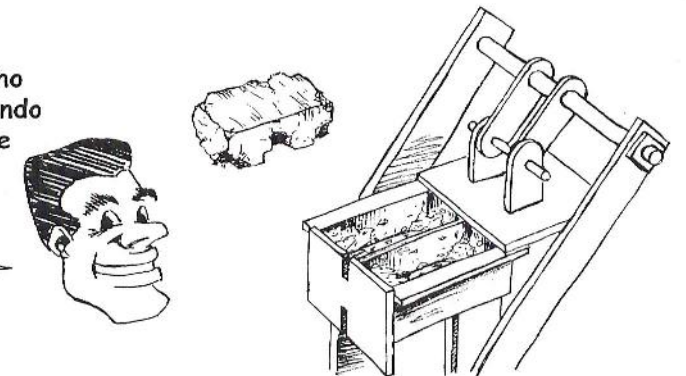

Ndithangue ineyo mbatizati kutoma tissafunika dziwa mataka khala mbadhidhi peno nkhabhe.

Ndimomwene pissatipedza kussankula nkala djadhidhi peno nkabhe.



Kulipo sussanguiza kwa kukhonga towera tidziwe kcuundu ya mataka.

**KUSSANGUIZA KWA NKAMBALA**

Tinakwata mataka akutota  
mbiti aikha maja mbiti a funhirira  
na phavu.



Pakufungula  
manja tissafuna  
tione mudhapita  
piala pakati pa  
dhongo ida  
funhirira  
ife manja.

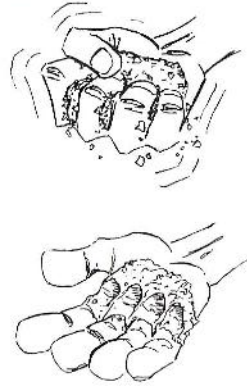

Tina potereza dhongo  
panghono panghono na piala  
pidha futuca pa mbuto ya  
dhidhi towera kutchita  
nkambala.

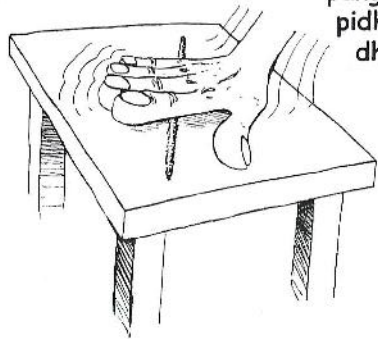

"Tinakuanissa kuchita nkambala inghono  
ya ntengo 0.3 macintimetro pissa pissa  
panguiza kuti tina dhongo ya kukwana."

"Tika khonda kuchita nkambala ou  
peno mataka akagomoka pissapanguiza  
kuti ya njipa."

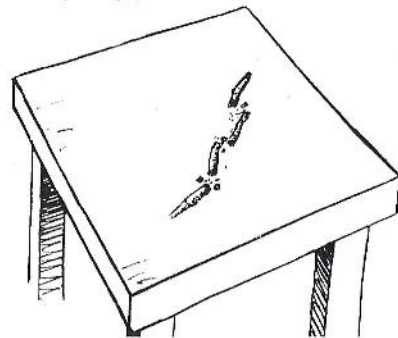
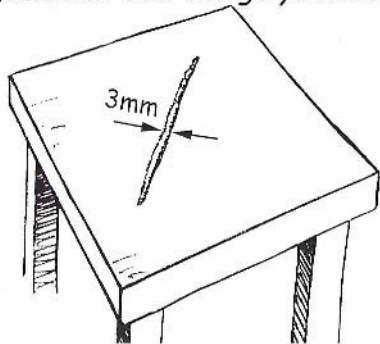

**KUSSANGIZA KWA NTHAMBO**

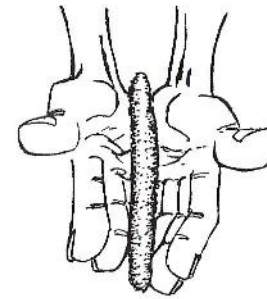

"Tinakuata panghono mataka mbiti  
ninga kandudhumbifikira centimetro  
ibhozi."

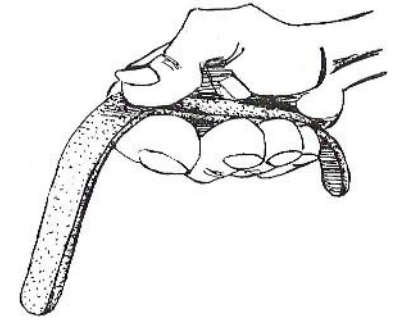

"Tingamala tinati tracanha na pichala cu  
cunghomo cuão mpaca cufiquira kukhala  
nthambo wa nghambala ya hafu (0.5cm)  
ya centimetro ya uquaquanha."

"Tinaphata muabhole mbhole  
mbitiona ulophi wa thambho  
mbizati kuguandika."

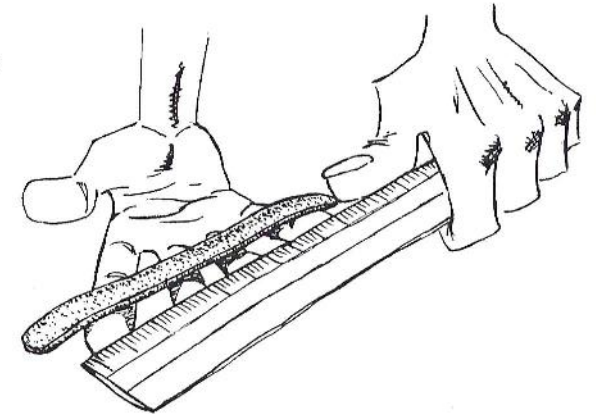

"Thambho wakulapa (25 na 30 cm)  
pissa panguiza kuti mataka  
anadhongo maningui."

"Thambo wacuvira (5 na 10 cm)  
issapangiza cua mataka ana dhongo  
yacuchepa peno panghono."

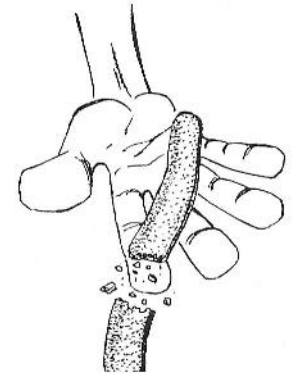
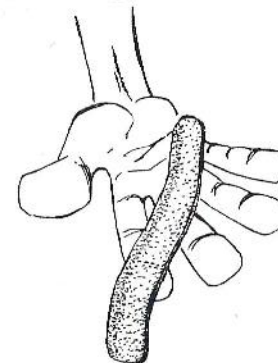

**CUYECEZA CUA NTENTE PENO CUA GARAFU**

"Tinakhuthula dhongo paghono ntente wakuphenekera npaka pakati na pakati."

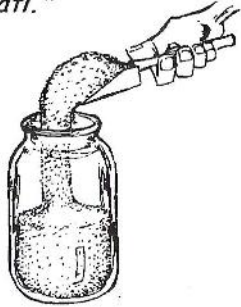

"Tingamala kwizunguza ntete mbitiikha pa khundu pa nzizi uthandhatu."



Tina zunguza ntete mpaca mphindi ibodzi.



Tingamala kuizunguza ntete mbitiikha pa khundu pa nzizi uthanthatu.

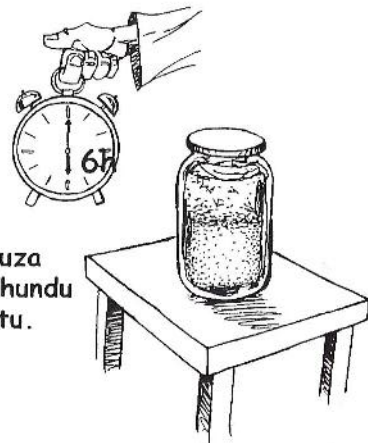

Tingafikira pa nzizi utanthatu tinaona pinazapinguiza kuciana cua mataka.



Penepi nghupanguiza cua cumuazana cua.

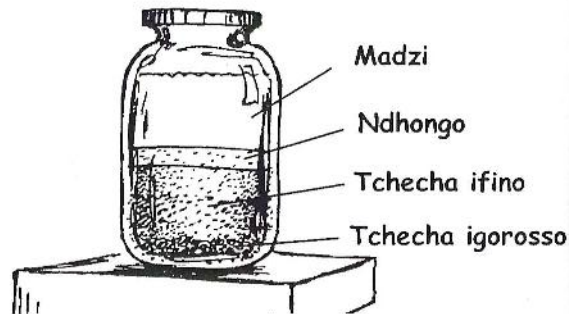

"Mataka ia dhidhi mbale anapanguiza na mapercento acucuana pincumi pi tatu (30) a ndhongo - ale na mapercento ia pincumi pi chano (50) ndio halimuadhidhi tay."

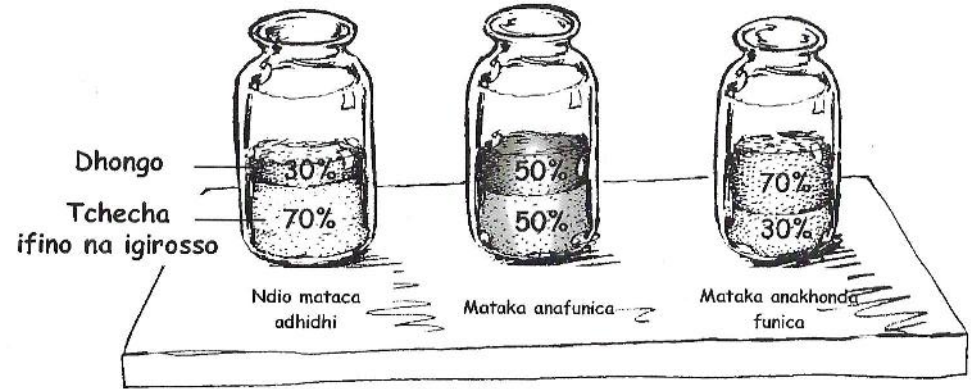

**KUECESSA CUACUNHALA**

Kuecessa cuacunhala safunica bocossi yamatabua yacucuana.

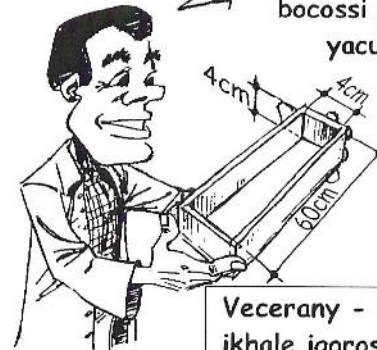

Vecerany - Bocossi issafunika ikhale igorosso towera madzi akhonde chucha.

Tinapukuta mbualo ma bocossi ineio na ntombue ya kuphuluzwa towera mataka akhonde kuphatirira.



Naipio tikhuthule mataka mbakhonda kuvungazua na pimya, mbitivunguza na madzi mpaka cudza matope.

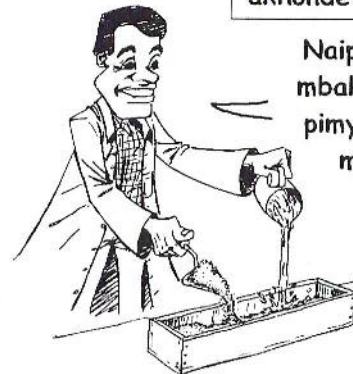

Tingamala tinatcindira padzulu towera aphantane.

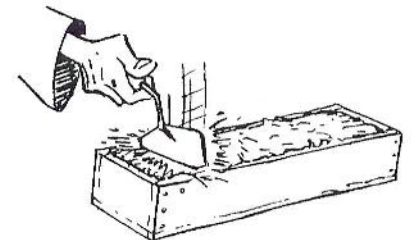

"Tingamala tinabhulussa tchecha ire idhangipa padzulu pa bocosse towera akhale na saize ibhodziene."

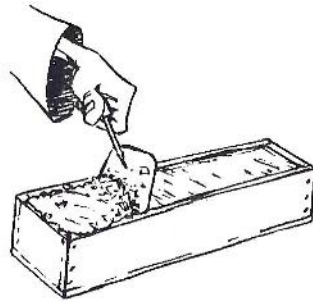

"Tingamala tina thuka bocossi mbituimissa pa sumana ya mumbhu pangakhala pa nthunzi."

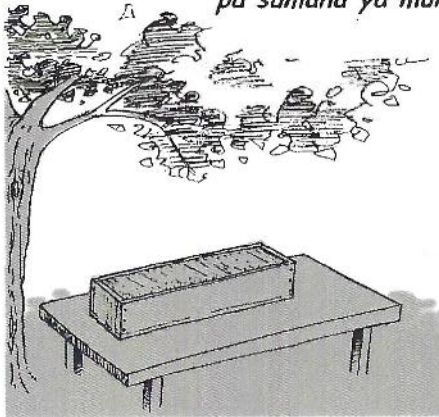

"Pangakhala pa dzua ntsico zitatu bassi."

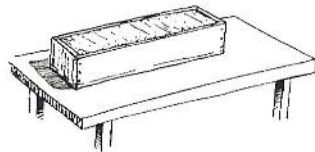

Ingatoma kuhuma tinaona cunhala cua mataka mbakhala naminhanja.



Cueneko nkupanguissa cuti nghunhala.

Ngamala penepi tinaguinha mpaca kughomo cua bocossi.

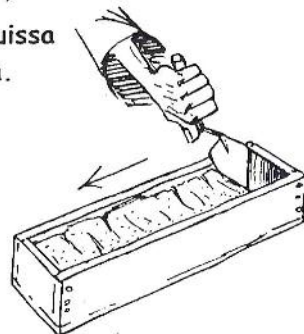

"Tingaiboma, mbuto inadzassala kakamue."

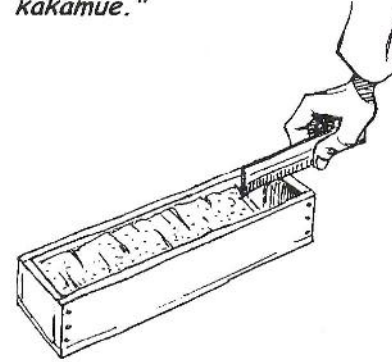

"Minhanza khupanguiza cuti ndhongo yanjipa tchecha na ndhongo."

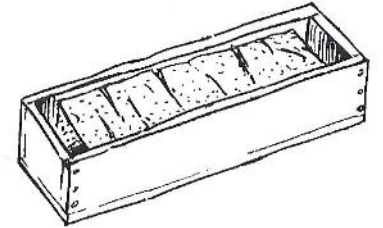

"Ingapanguiza cutupa pissatipanguiza cuti inadhongo ya kucuana."

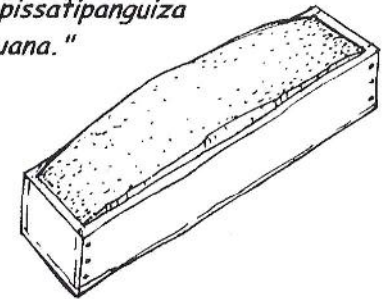

Cunhala cunghonda pitiza macentimetro mawiri (2cm), pissapanguiza cuti ya dhidhi podhi cucembedza naio.

Peno pissafunica thimizira tchecha mpaca kuvungazana mbikhonda pitirissa macentimetro mawiri (2cm).

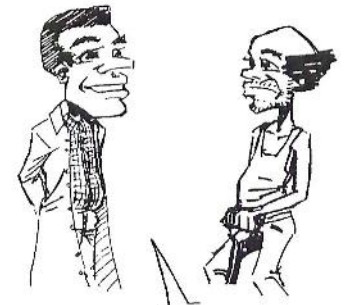

Nchichino mbationeny sabhussua tani njerua ya mataka na cemento.

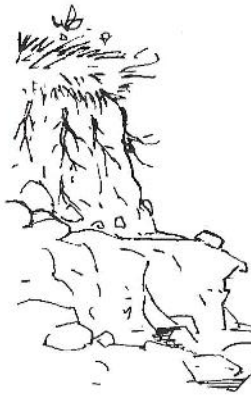

Pacutoma tinacunsa  
jenje mpaca kuphata mataka  
ia dhidhi.



Ndimo na thangue cuti njerua  
ya bhussua na mataka akukonda khala  
adhidhi nkhabe kuwanga.

Tinga humissa mua ntutu,  
anati aume cunja cua njerua  
bassi, mbuenhe nsualo muao  
mudhatota peno muna ntota.



Ndimo pissafunica  
kuhumissa patsico ibhodzi,  
mataka towera akhale  
na ntota uzinji.

Idhazati cu huma peno -  
iwissi peno idhatota

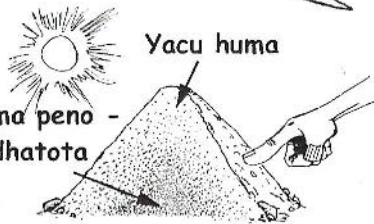

Nkabhe kuanissika pepeta  
mataka acutota na cuti mataka  
anaphatirira nchicero.

Mataka anghakhala na  
ntota, nkabhe vungazika na  
cimento, mpaka khala  
khainda iboziene.

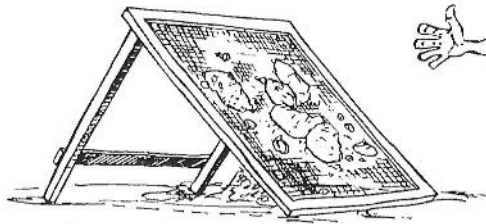

"Pissafunika kupepeta tchecha  
towera bhulussa pimyhala."

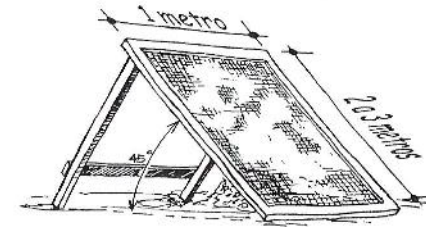

"Mpiadhidhi kuengula  
mataka na cefa ya  
0.5 cm (hafu)"

Tina engula tchecha pa cefa  
tingaponha pimyhala, pina engula  
mbipienda pantsi.

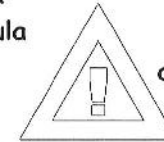

Pissafunica kuikha pa  
mbuto cefa inei yakuwengula  
nayo mataka duzi na mataka,  
angalimissua piadhidhiene issa  
engula muadhidhi muene  
tchecha ifino.

Tchecha yacuchena  
inagua pantsi pa cefa.

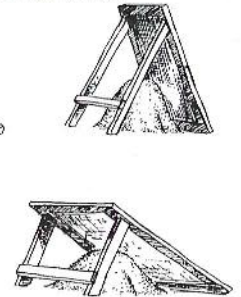

Tingamala pionece,  
tinatoma vunguza tchecha  
na cimento.

Pissafunika kuona khaindi yanji  
ya tchecha idhacembenda wa ife,  
mbitionambo cuti tavungazatany  
tchecha na cimento.



Pacutoma tinaumba njérua na ntengo ya 1:12 inaphatissa maningui bhassa.



Ndininji nkuku wakuvungázua?

Ndio ntengo wakuciana ciana wamu vunguiziro.

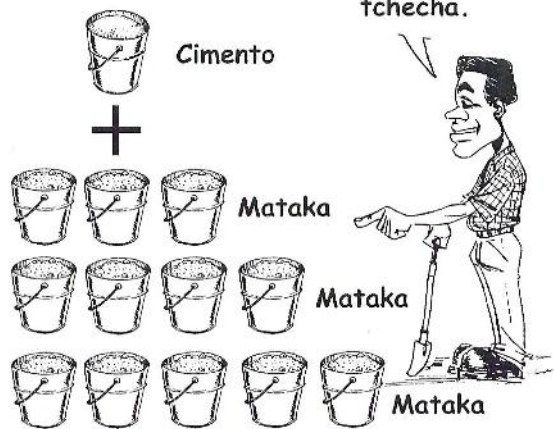

Ntengo wa (1:12) sapanguiza volume ibhozi ya cimento towera kuhumba ncuto wa 12 wa tchecha.

"Mphiadhidhi kuphata massa na piombo ninga barde pelo chibarra."

"Langanane - sakho ibhodzi ya cimento ya 50 (pincumi pi chano) pia kilu pissapangui 40 (pincumi pi nai) nhamagongue."

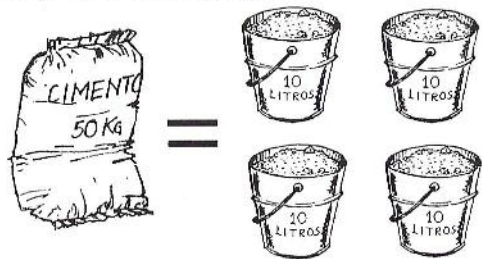
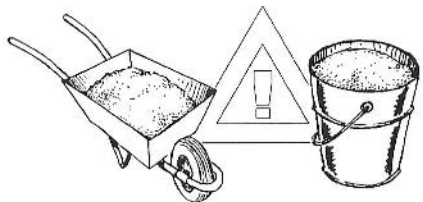

"Ntengo wa chibarra, saize yache njacuciana ciana."

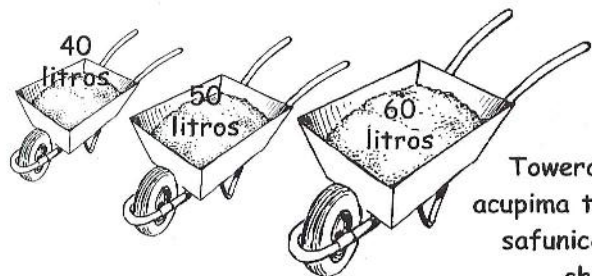

Towera kalira madhodho acupima tchecha peno cimento safunica khala na chombo chibhodzichene.



Towera vungaza tchecha na cimento pa ntutu wa (1.12), pacutoma tinatoma vunguza barde ibodzi ya cimento na ncuto wa 12 (pincumi na piwir) mabarde ya tchecha, pondho na mabarde mawiri ya madzi.

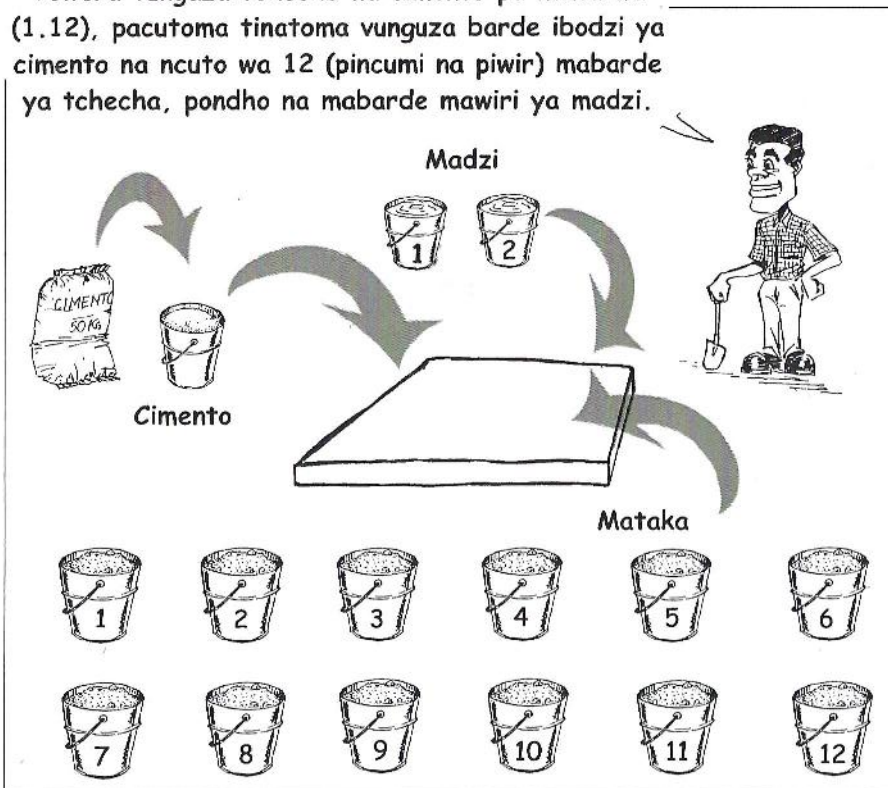

"Tingamala tinavunguza cimento na tchecha mpaka kukhala khainde ibhoziene."

Patsogolo tina muaza tinamuaza mpaka kufiquira ulaphi wa centimetro a macumimatatu (30), towera madzi akuane mbakhonda taika.



Pissafunica madzi mazinji pa kuvunguza tchecha na cemento ?



Tingavunguiza na madzi panghoono ?

Nkhabhe kanhika, nkhabhe wanga.

Ndimu, njerua ingahumbua na madzi acunjipa, njerua inei nkhabhe kuwanga, mbissueka.



Mbitivungazeni cemento, tchecha na ntengo wa mabarde mawiri ya madzi na regador.



Vany! tikhonde vungaza cemento na tchecha na madzi ya munhu, pezi njerua nkhabhe kukhuma.

Tinavungaza muadhidhi muene cemento, tchecha, madzi, mpaka kukhala na khainde ibhoziene.



Tinapiziwissa tany cuti ntengo wa madzi akuana ?



Hapinanessa tany, alipo maonero aruanghessa.



Tinakuata panghono uvunguziro wa cemento na tchecha akutota, mbitiakanha manja na mbhanvu.

Tingafuthula manja, dhongo issafunika ineke mudhapita piala.

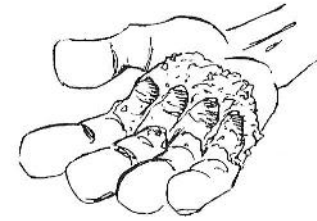

Tingaaguissa bhulukira pa metro ibhozi (1m).

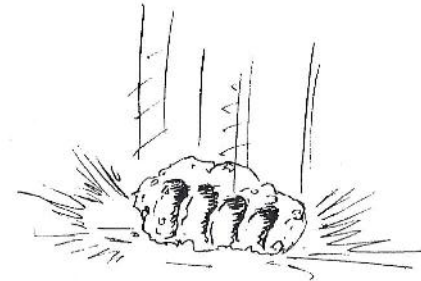

Ndhongo inganhedzeka wazika, pissapanguiza kuti ndhongo inei yanjipissua madzi.



Ndhongo inganhedzeka ndithangue kuchepa cua madzi.

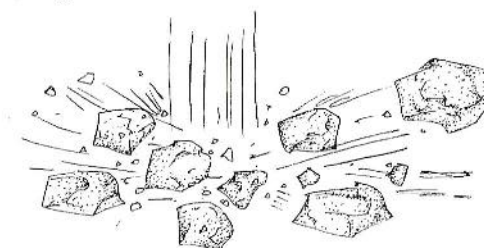

Ndhongo inganhedzeka maphindi macula macula issapanguiza cuty ntengo wa madzi wacuana.

Pingafunika kuthimiza madzi peno kumuaza dhongo mpaka kukuana ntota wadhidhi peno unafunika.



Langhanany tingakhala dhongo ya cemento na tchecha safunika tiziwe ntengo wa njerua ana funefe kuhumba pa nzizi obhozi.

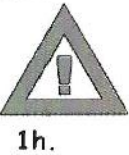

1h.

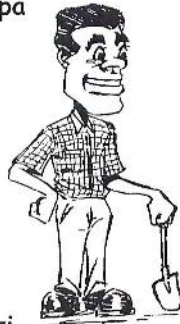

Bulikira pa nzizi ubhozi tingapitiriza tingaumba dhongo mbitikhonda kumala kuhumba tinati tikhonde kuaumba ntendo za njerua zikhafunefe.

Mbo, tinaio dhongo ya cemento na tchecha pinafunika tchacutoma kuhumba.

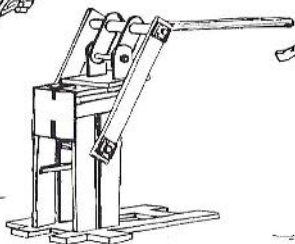

Mbitizati kuahumba njerua safunika kudziwa bokossi ina njeruauy kuti tinaiphatissa naio bassa na cuitemeza.

Mbatidziwenimbo makhanhiro.



"Kukanha nditowera ndhongo iwangu mbikhonda khala na mabhenga nkati mua bokossi."

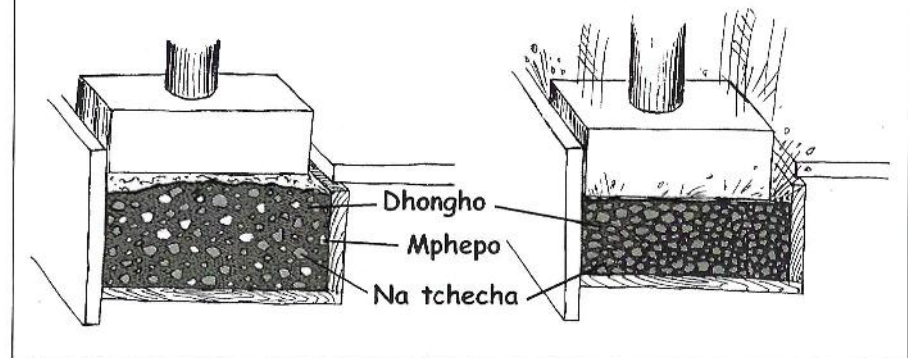

Dhongo  
Mphepo  
Na tchecha

Tengo unafunika wa cemento tovera yikhue bokossi issafunika ikanhue muadhidhi tovera njera zikhonde ciana.

Tingakhonda kanha muadhidhi tinazakhala na njerua zakukhonda khoma, pabhozimbo na mafufu nghabhe khomiua.

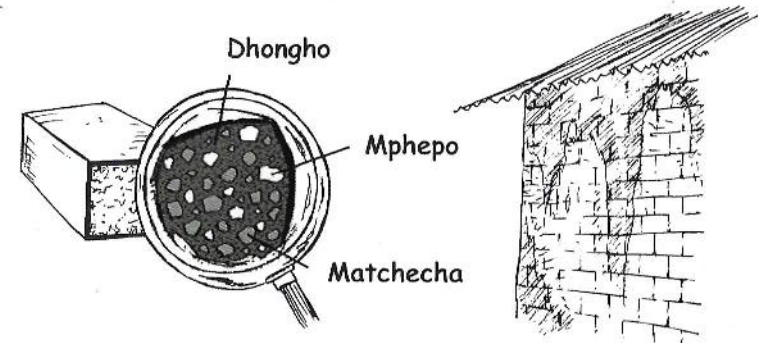

Dhongo  
Mphepo  
Matchecha



Njérua zingapitiriza kukhanhua mzizi uzinji, assapassa madhodho pa kumanga nhumba, peno tingaitinha penombo tingaikha majolejo.

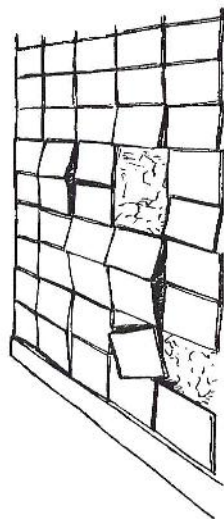

Mifendo ndi matata yakukanha njérua pa kudzaza bokossi....

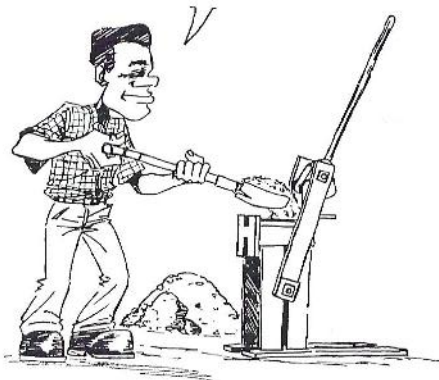

... Kuatsindira

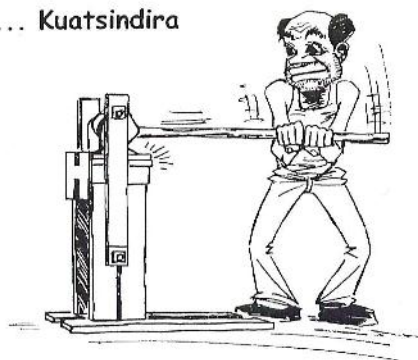

... Kubhulussa njérua bocossi.

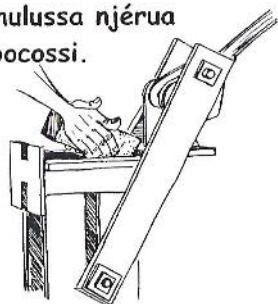

Tinga mala tina ikha pantsi pacundhumezua towera ihumissue, penepi pina dzachitissa kuwanga kua njerua.



Tingaibhulussa njérua towera kuhumissa safunika cuti tiibhulusse muabhole mbhlole thangui yio inanthota, ghopessera kugomoka.

"Ingahumissua muakundhembuka, njérua inei issakhoma khakamue, ndhi thangui inei, mbaticieny sambo wakuumissa njérua pa mphepo peno pa dzua."

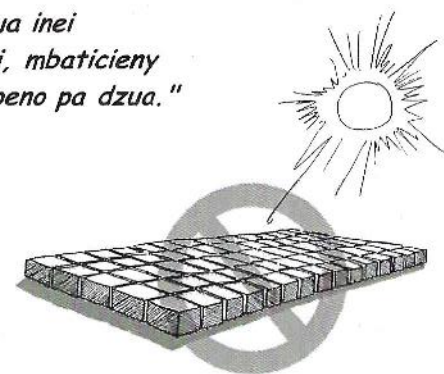
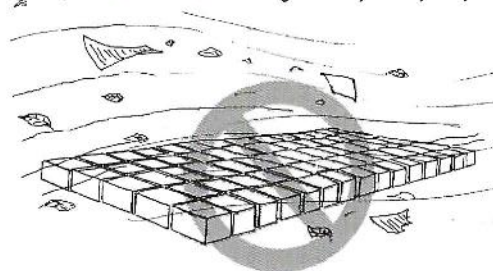

Pantsico ziwiri, angahuma safunika kuawazira madzi mawiri pa ntsico.



Zingapita ntsico ziwiri tinagumana njérua, mbitipitissa cua wazira madzi, kawiri pantsico.

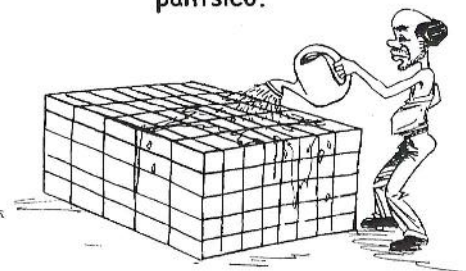

"Tingamala kuwazira madzi, tinaphimbira na olhado."

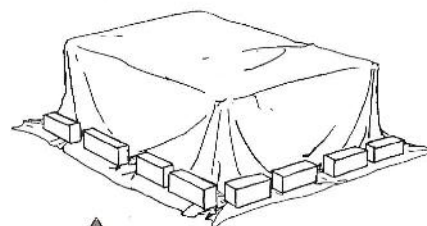

"Ingapita sumana mbadagumanha ale, tinati tissie kuathirira madzi pa ntsico zacuana macumi ma wiri na ibhodzi (21), unga pita nzizi unoio wa ntsico makhumi ma wiri na e bhozi anzaphatissua bhassa."



"Mbatikhondeni kugumanha njérua patsi mbapakhala na madjenje, anazapandama peno kussueca."

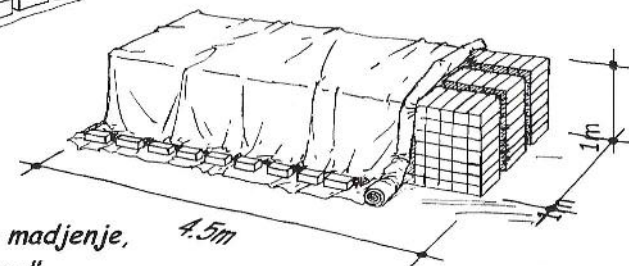

Tingakhonda kuadhingha pa mizi nahumbefe, njérúa zinati = zikhonde khala zamasso.

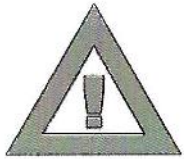

Towera kupheza ale anakanha njérúa towera adziwe ntengo wache, alipo matchitiro ache akukhonda kunentsa.



**KUDZINGA NA MASSO**

Tissaona peno njérúa nghabhe nghomo zakucueca Yakukhonda lungama Peno na maipiro anango

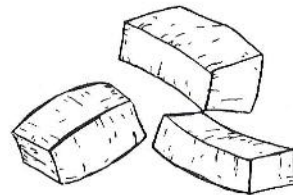

Maipiro anewa a njérúa anazapassa madhodho pa mizizi inamanguepe nhumba, nhumba inei nkabhe khuma.

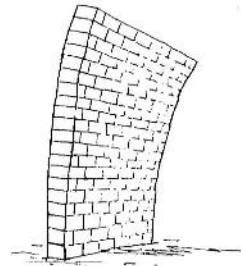

**KUDHINGA NA KUPASSA NZIZI PA MATCHITIRO**



Madjerua ounse adhakanhiwa anafunika khala na saise ibhoziene, mbakho siana pa ulaphi wao.

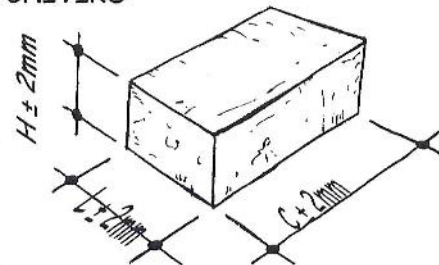

Panango kuciana cua njérúa safunika kukhala na ulaphi wa milimetro mawiri (2mm).

**MATCHITIRO AKUMALISSA**

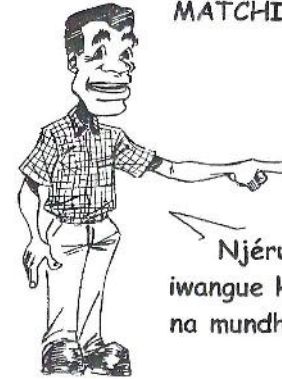

Njérúa issa funica iwangue kuti inga kuwiriwa na mundhu ikhonde sueca.



**MACHITIRO AKUGUA**

Mbatiquiceny njérúa paulaphi metro ibhozi na hafu (1,5m).



Inghakhonda sueka inei ndi njérúa yakukhoma.

Mahonero a dhidhi

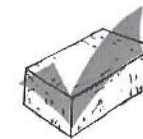

Mahonero ya akuipa Nakuona matchitiro

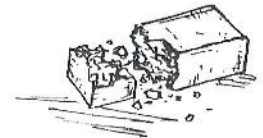

**MAHONERO ANHONGOLORO NA KUHUMISSA**

Na mahonero aneuwa, tissafuna kuona kuti njérúa anakuanissa kha mbadatota mbahuma kazinji kene.



Tinaibhiza mbhacia yacuzdala na madzi, njérúa ibhozi pa nzizi khumi na mawiri.

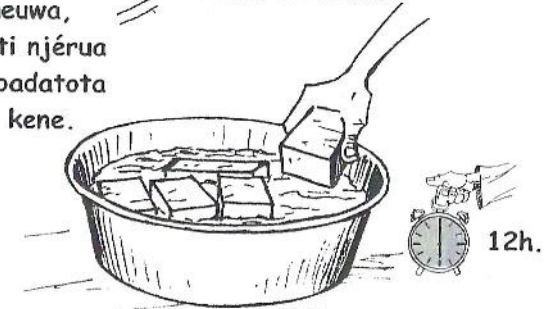

"Tingamala tinai nula mbitihumissa pa mizizi khumi na uwiri."



Tinapitiriza na matchitiro anewa mpaca sumana yanumbe.



Ntsico zinomuwe mbadamala kale kuvhikua...

Ikhany manjêrua, khala asueca peno nkhabhe.



Mahonera adhidhi

Khala kuti njêrua asueca peno mbhakhala na nhanja, safunica kuathimizira cimento, peno cimento inei yamala mphanvhu.

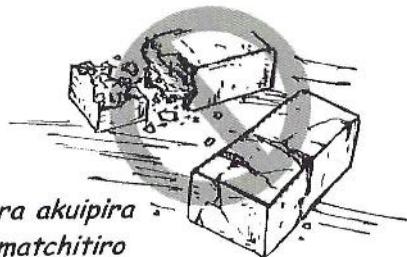

Mahonera akuipira Kuona matchitiro

MAHONERO AKUBULUSSA MADZI

Mbiadhidhi tikuate njêrua mbitikha pa peso towera kuziwa tengu wache unalemerea.

Njêrua ichi issapezar makilo akukuana matatu (3kg).

Mizizi yacukuana makhumi mawiri na inai (24), mbidhahvikua madzi.

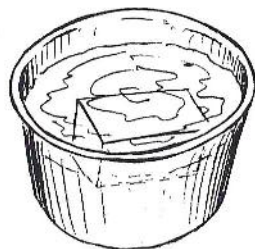

24h.

24 horas depois...

Mbatiinuleny njêrua manzi mbatipukuta.



Ndimu pakutoma njêrua ikhalalemera na makilo akukuana matatu (3kg), lero irikulemera na makilo akukuana (3.4kg).



MBATIZATI KUIPEZERA	MBIDHAMALA KUIPEZERA	x 100 = KUMUA
MBIDHAMALA KUIPEZERA		
$\frac{3,4\text{Kg} - 3\text{Kg}}{3\text{Kg}} \times 100 = 13,33\%$		

Na ipio na matchitiro anewa tinati tidziwe tengu wa maporcento akukuana 13.33%.

Tinga mala mbiadhidhi cupezar pontho towera tioune makilo mankassi.

Na ipio lero irikulemera na makilo akukuana (3.4kg).

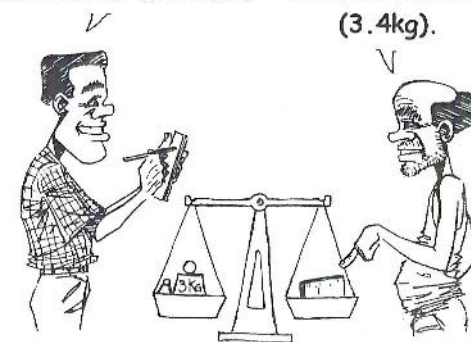

Ninga na njêrua ichi, inadzamua madzi akubhulikira maporcento acucuana kumi na ziwiri mpaka kumi na zichano (12 -15%) ya madzi.



Inga pita madhikhoro outse a njêrua, tinatoma kuakanha ?

Ndimu nchinchino, tinati kukanha njêrua zizinji.

Mbationeny mbuto zire zinakanhirua njêrua za cimento na tchecha.



Pa kukanha njérua za  
cimento na tchecha inazakaoneza  
mbuto ibhozi mbicebhedza a  
anthu achanu (5).



"Pa mbuto ineio ya anthu achanu (5),  
atatu (3) alicuvhungaza tchecha na cemento (awiri)..."

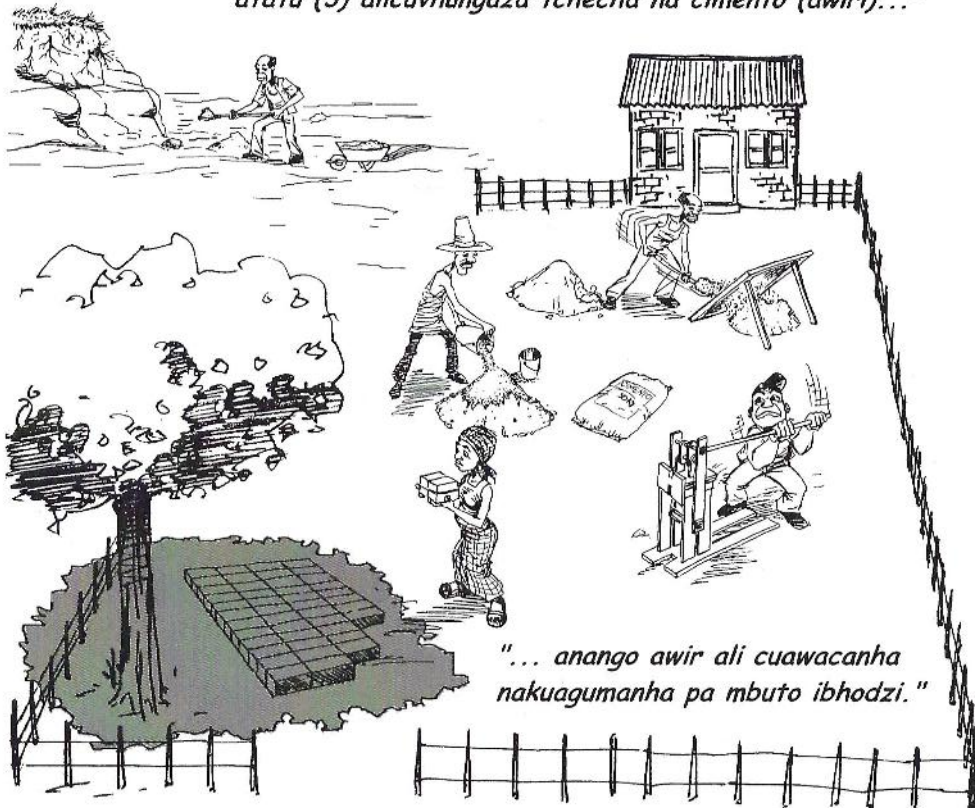

"... anango awir ali cuawacanha  
nakuagumanha pa mbuto ibhodzi."

Ugaxugaxu unafunika  
na bokossi ndio uchu.



Kuissuca muadhidhi mbualo  
mua bhokossi inakanhirua njérua  
ntsico zoncene, hungamala phata  
naio bhassa.

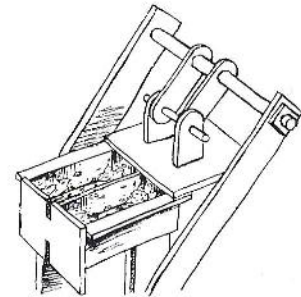

Cui Khuaza mafuta bokossi  
mbuto zire zinafunika, ntsico zoncene  
tingamala bassa. Ninga kuikha mafuta  
akiupia apharafino. Peno kuikhuaza  
na mafuta akuja na trapo.

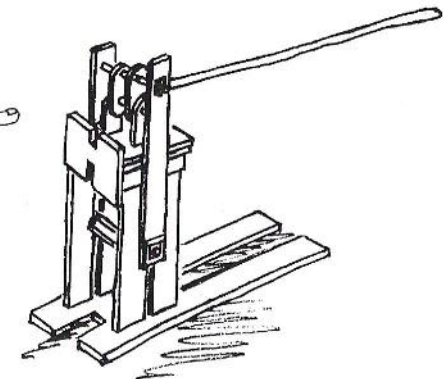

Tingamala pionsene  
ipi mbatipumeny paghoono.  
Lero ndi tsico idhaphatefe  
bassa ikulu.



## Ficha Técnica

### Título

Manual de Produção de Blocos de Solo-cimento

### Promotor

Ministério das Obras Públicas, Habitação e Recursos Hídricos

Direcção Nacional de Urbanização e Habitação

Av. 24 de Julho, n° 2341, 4°-5° Andar

Maputo

Tel: +258-21 430 439

Fax: +258-21 320 424

### Equipa Técnica

Dino Coutinho (Engenheiro Tec. Civil) - Chefe do Dep.to de Estudos e Projectos

Jean-Paul Vermeulen (Engenheiro Civil) - Assessor

Maria Sofia dos Santos (Arquiteta e Urbanista) - Chefe do Dep.to de Habitação

Adérito Wetela (Arquitecto e Urbanista) - Consultor

### Coordenação Geral

Ângelo Benesse (Engenheiro Civil) - Director Nacional de Edificações

### Colaboração/Apoio Técnico

Direcção Nacional de Habitação e Urbanismo

### Tradução

Ricardo Jose Luis

### Patrocínio



Tiragem  
120 exemplares

Distribuição gratuita - Permitida a reprodução

Maputo, Fevereiro de 2019