

fact sheet



Family tent, 16m²

Background

*This new family tent has been developed in collaboration with ICRC and UNHCR to guarantee a product fit for human use in all climates, with appropriate outdoor life span and a minimum cost. The detailed specifications are available on the emergency items catalogue **TENT, FAMILY, 16m² double fly with ground sheet** CODE HSHETENTF16C.*

The most recent family tent is based on the design of a standard commercial tent, adapted for our specific shelter needs in the field.

Twenty years ago, humanitarian organizations would generally supply traditional Pakistani tents: ridge type, heavy cotton cover, single and double fly. But these tents were difficult to use due to the weight of the heavy canvas, and pipes, as well as the poor durability of the canvas as they were treated for desert conditions rather than tropical. After the Rwanda crisis, where many of these tents collapsed in a few weeks, the decision was made to use polyester-cotton blend canvas with more advanced rotproof treatments. This resulted in a 20 kilogram reduction of weight to the structure, as polyester-cotton blend is lighter than cotton, and better durability in hot and humid conditions. Last year, the family tent was adapted further: heavy pipes were replaced with light pipes and more improvements were made to the polyester-cotton blend canvas reducing the total weight of the structure to 55 kilograms.

Planning the response

Before distributing family tents, establish that there is a need for them. Be aware that the tent is a transportable temporary shelter with a cover and a structure. The tent is designed for short term only. However, some parts such as the steel pipes, canvas and covers can be reused after the emergency phase.

Choosing the best emergency shelter option requires taking into consideration various parameters.

Before you start, consider the following:

- Will tents help meet the shelter need? Will they reduce the vulnerability of those affected by the disaster? Would other emergency shelter solutions be more useful than tents? To support reconstruction, consider host families/communities and local materials/tools which may help with longer term reconstruction. Other solutions may be available more quickly and at a lower cost than a tent and may facilitate the recovery process.

- Are tents a culturally appropriate solution? For example, take into account the fact that there are limited internal partitions in tents.
- The family tent is designed for an average family of five members.
- Are tents appropriate to the climate conditions? In cold environments, the tent is difficult to keep warm as it loses heat quickly, and therefore should be complemented by a winterisation kit such as a stove, floor insulation and a mattress. Note that in extreme cold climates, tents should be avoided.
- A tent is a costly item (approximately CHF 310, not including storage and transport costs) so distributing valuable items like a tent may cause inequality and resentment in the population.
- It may be difficult for people to put up a tent if they have never done so before and technical assistance may be required.

The distribution of emergency shelter may also require intervention from other sectors such as those distributing non-food items and those providing access to facilities such as water and sanitation and health.

Description

The new family tent is a ridge tent with elevated walls.

It has 16m² of main floor area plus two 3.5m² vestibules for a total area of 23m², double fold with a ground sheet. To assure stability, the outer tent is supported by 3 upright poles, 1 ridge pipe, 6 side poles, 4 door poles, 3 guy ropes on each side and 2 guy ropes at each end.

- The outside dimension of the tent is 4m wide, 6.6m long including verandas and has a centre height of 2.2m.
- The double-fly tent and all accessories (including poles, pegs and sledge hammer) are packed to ensure that the ground sheet protects the tent and accessories, and the metal poles and pegs do not pierce the bag. Assembly instructions are included inside each package with assembly instruction drawings.
- The outer-tent roof and inner- tent canvas is polyester-cotton blend and the groundsheet follows the plastic sheeting standard.
- Weight per unit is approximately 55kg.
- Volume per unit is approximately 0.20cbm.
- Approximate price per unit is CHF 310.

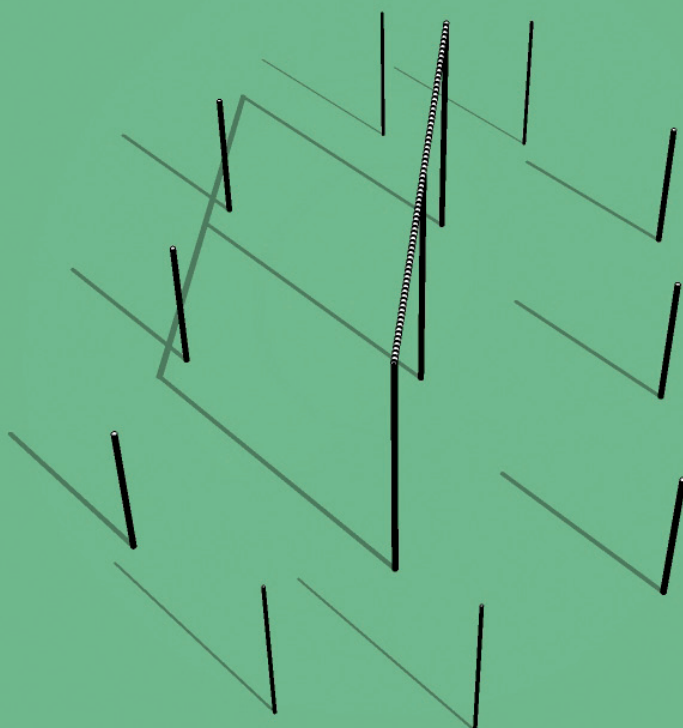

Recommendations

How to do a proper layout

- Choose a safe site away from polluted water, landslides and falling rocks. Make sure it is well drained and safe from floods when it rains.
- The layout should take into account sphere indicators on firebreaks, minimum distance between tents, total open space per person, minimum covered space per person, and minimum distance and facilities per person for water points, latrines, washing facilities and refuse bins. Sphere guidelines suggests providing at least 45m² per person for the whole site including facilities such as water taps and roads, as well as 3.5m² of covered space per person in hot and temperate climates, or, 4.5m² per person in cold climates. By these standards (16m² main floor area plus two 3.5 m² vestibules for a total area of 23m²), the family tent should only hold five people in hot and temperate climates and incorporate additional space for cold climates. Approx 67m² of usable space is required to erect the tent. This includes space to anchor the guyrope.

How to do a proper installation considering climate conditions

- Keep guy ropes tight to prevent tent the from sagging. Also dig drainage ditches and bury mud flaps (20cm overlay) in a trench.
- Orient doors away from prevailing wind.
- In hot and humid contexts, tents provide shade from the sun. They should be well ventilated and have appropriate drainage.
- The tent is able to withstand a **75km/h wind** without any damage and remain securely attached to the ground without any loss of tension. However, to guarantee stability, regularly strengthen the canvas using the ropes, fixings and pegs. Avoid retention of raining waterwith the strengthening patches.

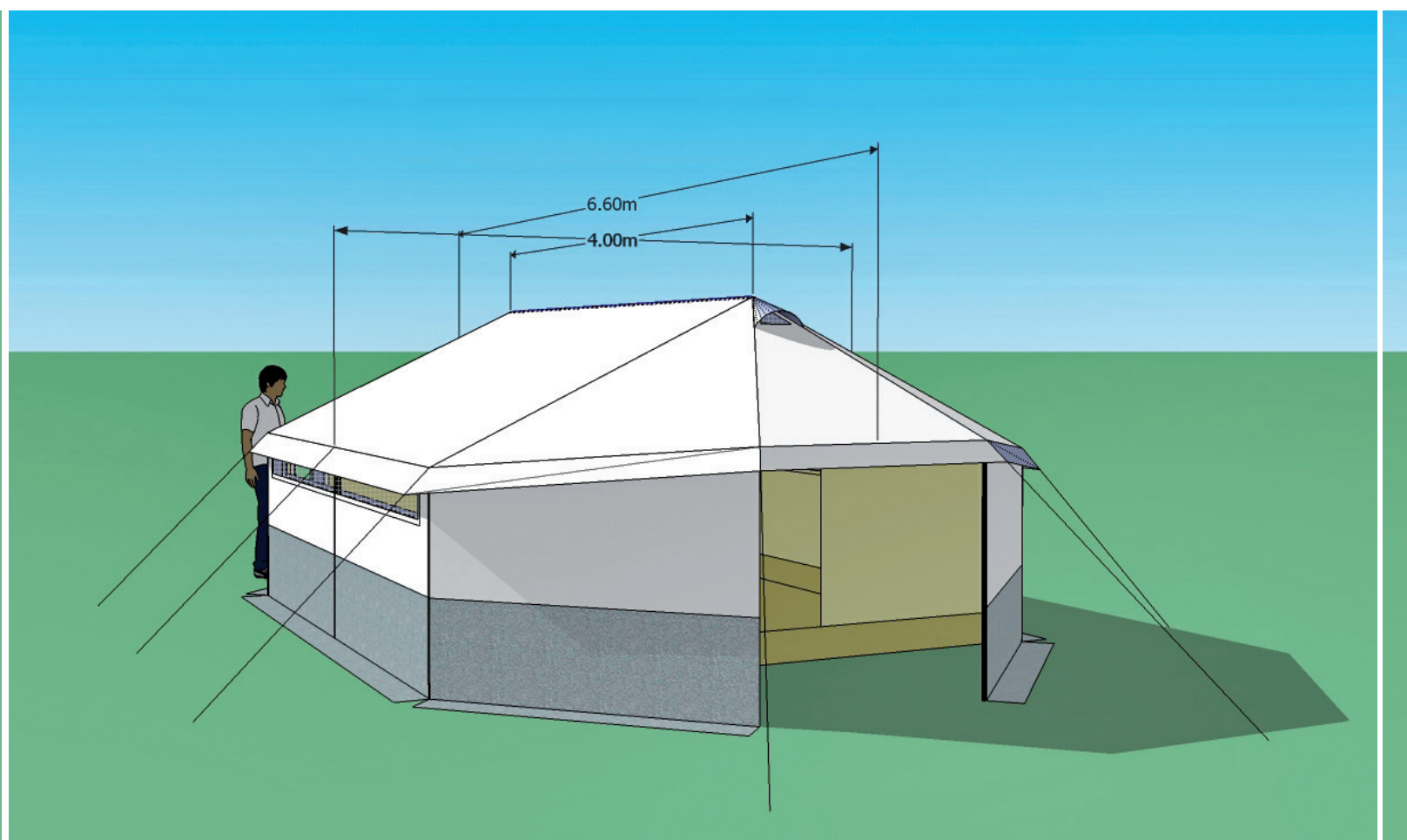

Family tent, 16 m²

4

How to be fire safe

- Mitigating actions should include the provision of a 30m firebreak between every 300m of built-up area, and a minimum of 2m but preferably twice the overall height of any structure between individual shelters to prevent any burning structures from touching adjacent tents. Increase the separation if building materials are highly flammable.
- Efficient stoves and flue pipes that burn appropriate fuel are essential.
- The stove must be located away from the tent wall and chimneys must have caps to prevent sparks from falling back into the tent. Chimneys should pass through the heat resistant fabric (non perforated).
- Some ventilation must be maintained, especially when stoves or fires are used. When cooking or heating takes place in a tent, health risks include tent fires, respiratory disease and eye infection from smoke..
- When possible, communal cooking facilities are the most appropriate.

How to increase the lifespan of tents

- It is possible to stockpile tents for a 5 year minimum without degradation. However, tents should be store properly, protected from the sun, vermin and water. Tents should be stored elevated from the ground in a dry, clean and ventilated warehouse, a 1/2m away from walls. Tents are sensitive to rain and moisture when packed. Regularly check to ensure that they are not damp and rotting.
- The tent can be expected to have a **minimum 1 year lifespan**, maintaining its sheltering and waterproofing capacities in all types of climates.
- A repair tent should be built to provide spare parts and equipment, in order to repair canvas or broken poles. •

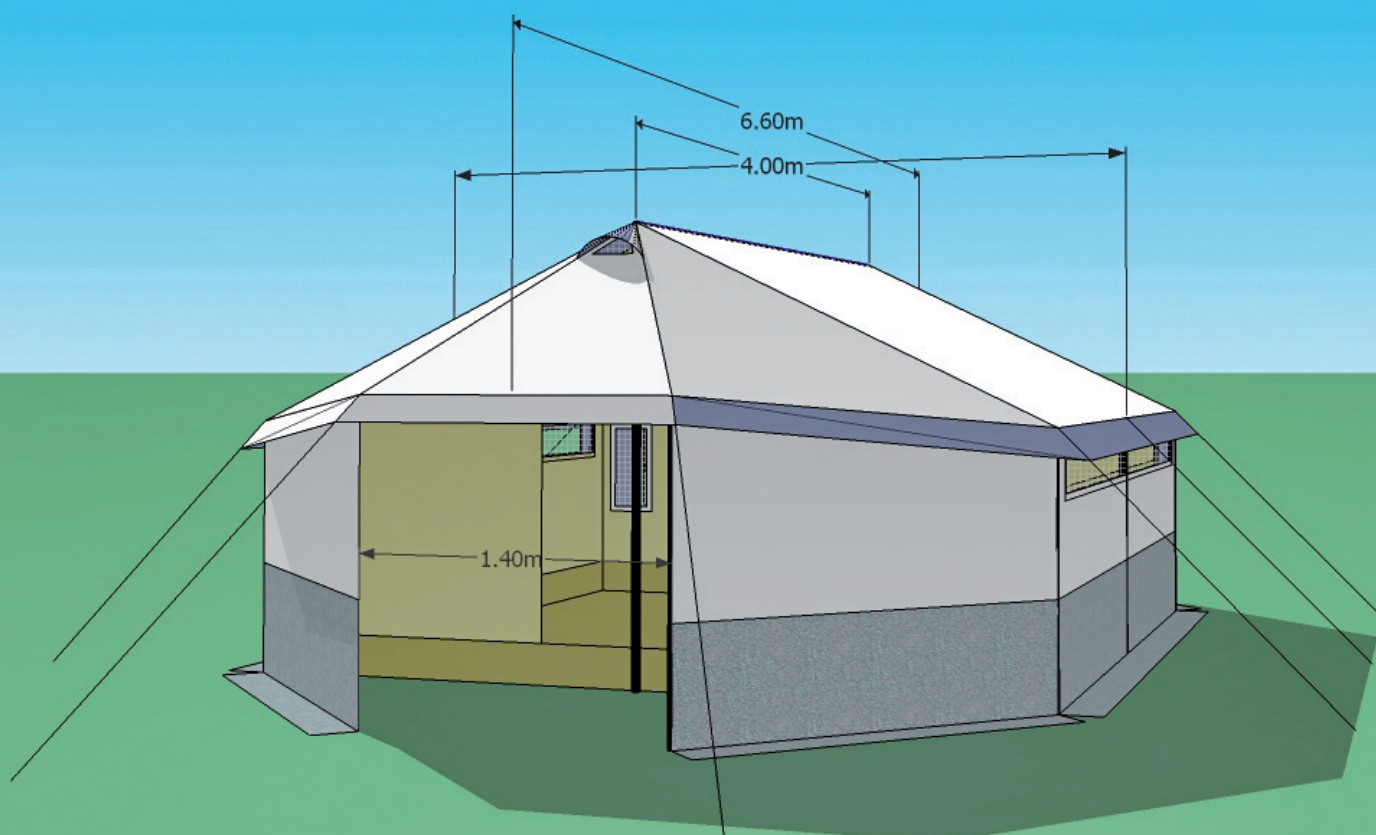



Packing list for a standard tent package

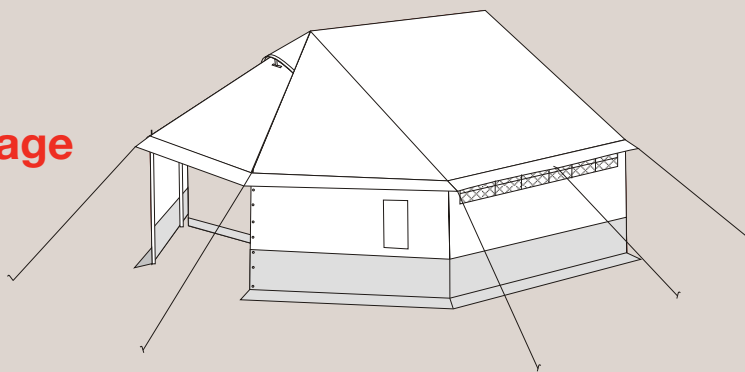

Content



outer tent x1



inner tent x1



ridge pipe of 4m in 2 pieces x1

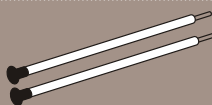

upright poles of 2.20m x2

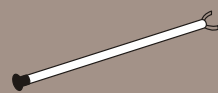

central pole of 2.17m x1



side poles 1.25m x6

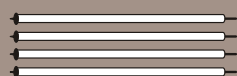

door poles 1.40m x4



guy ropes of 8mm x6



angled iron pegs of 350mm x6



guy ropes of 6mm x4



candy cane pegs of 300mm x4



pegs of 230mm x26



hammer x1



set-up instruction x1

Optional

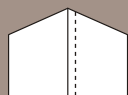

pair of inner partitions x1



inner partitions x2

x3



Ideal to assemble this tent.

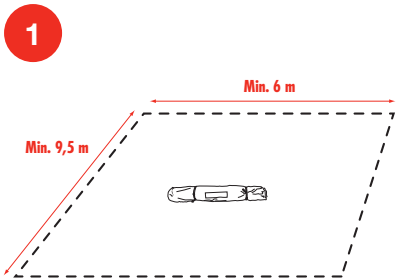

Place the package at the exact place where the tent will be erected.

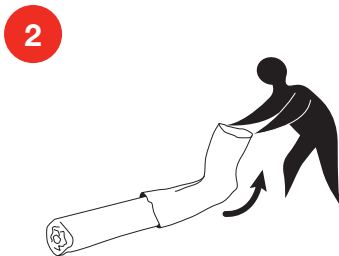

Remove the bag.

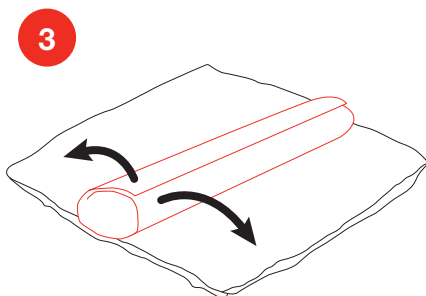

Unroll the bundle.

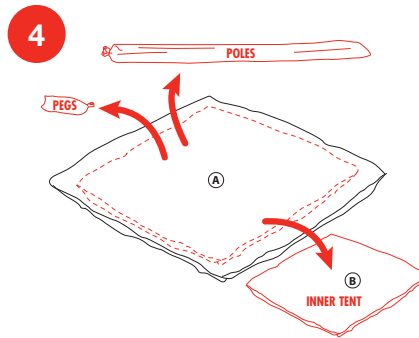

Take aside the bag with the poles and the accessories bag.



Unfold the outer tent canvas (the part made of heavy canvas, and carrying the ropes.)

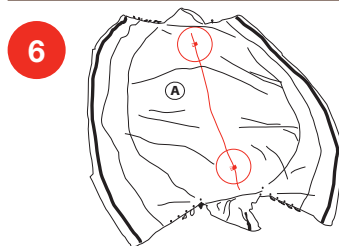

Place the outer tent canvas inside up to make the ridge line visible. To identify the ridge line, look for the two Velcro sleeves, and also see the two triangular vents at each end of the ridge.

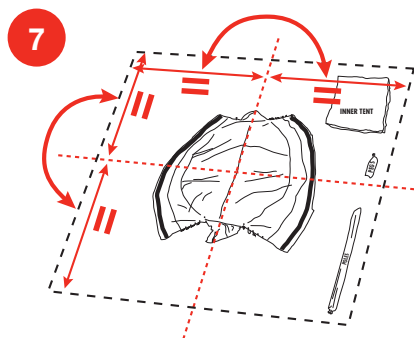

Align the tent canvas into the appropriate direction, according to the site planning.

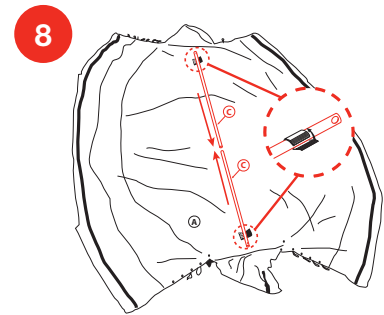

Assemble the ridge pipe and place it on the tent canvas, attach it with the two Velcro sleeves.

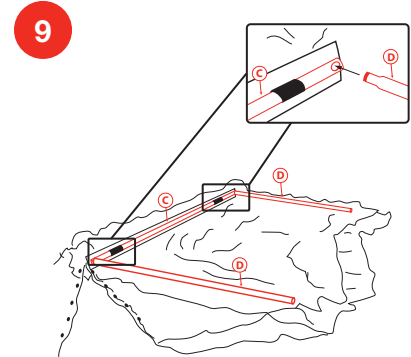

Place the two upright poles, one at each end of the ridge pipe.

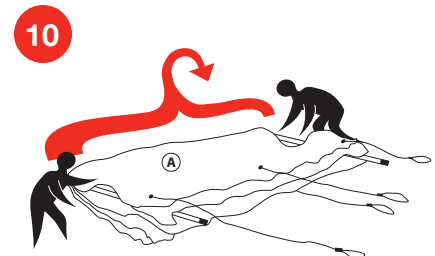

Fold back the outer tent canvas on the previously installed pipes.

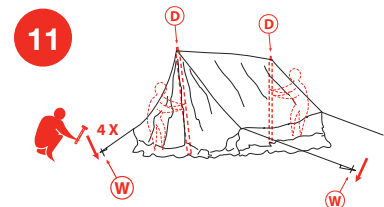

One person at each end taking the upright poles, pull up the tent. The third person places the 4 corner pegs into the ground as per the indication from the pitching plan, attaches and tensions the guy ropes of the 4 corners of the tent. At this stage the tent should stand up by itself.

12

Ventilation cone.
Place the rod in the sleeve.

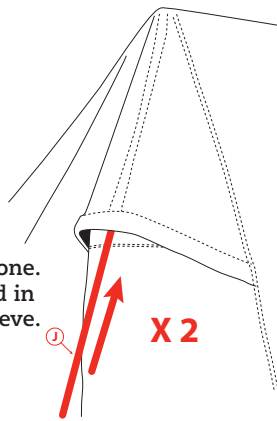

16

Complete the tensioning of the 10 guy ropes, adjust the position of all poles to be properly upright, to obtain the correct well tensioned shape.

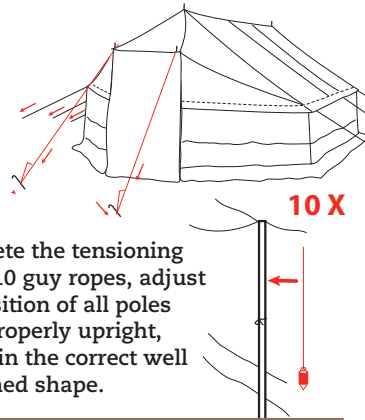

19

Turn the inner tent in a way that the position of the chimney pipe protection corresponds to the one on the outer tent.

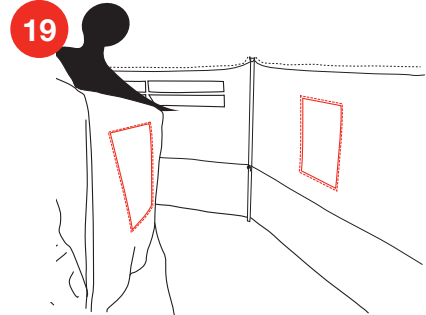

13

Place the 6 side poles and the 4 door poles on the inner side of the tent, attach them to the tent with the inside laces.

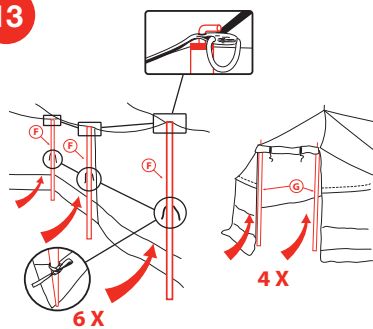

17

(A): Once the shape of the outer tent is appropriate, fix the bottom of the walls to the ground with 22 pegs, from outside.

(B): If possible, make a trench to bury the outer tent mud flap into the ground.

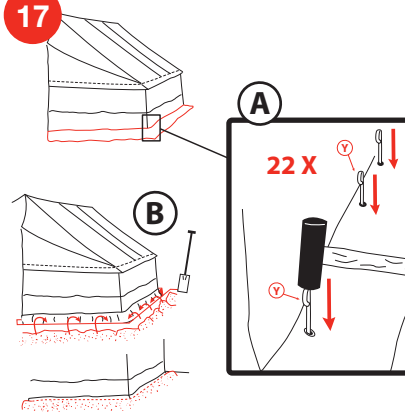

20

Hang the inner tent to the ridge pipe, start first with only one hook at each end of the ridge pipe (A), then attach the inner tent to the upright poles with the laces (B), and then place the remaining 6 hooks on the ridge pipe (C).

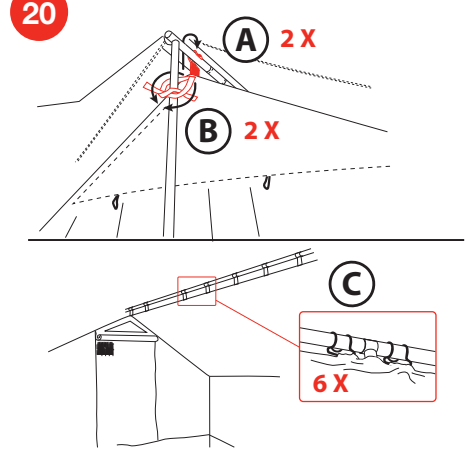

14

Place the remaining 6 pegs, attach and tension moderately all the guy ropes.

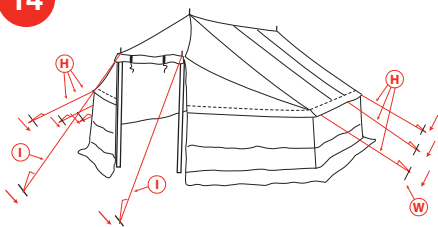

15

Close completely the 2 doors

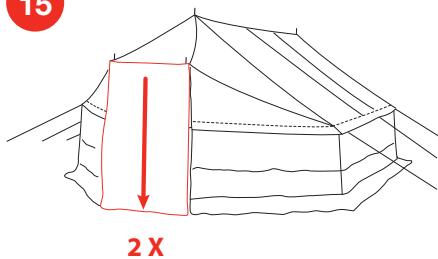

18

Open one door, get inside the tent, and unfold the inner tent.

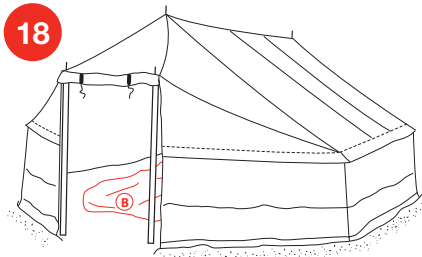

21

Hang the inner tent side walls to the side poles, using the 16 hooks and the 10 D-rings at the top, and the 6 at bottom of the walls. Start from the middle, and finish by the door side.

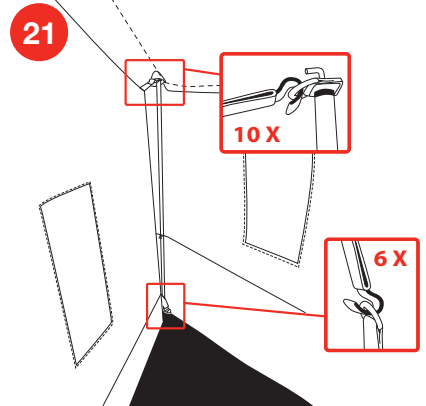

22

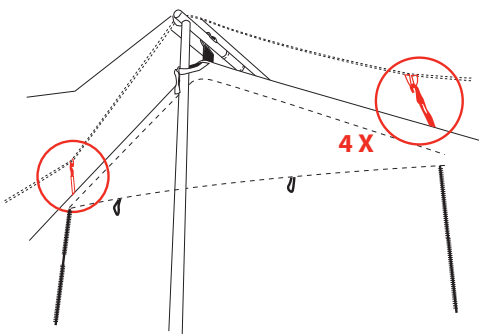

Attach the toggles to the loops at the top of each door zipper.

23

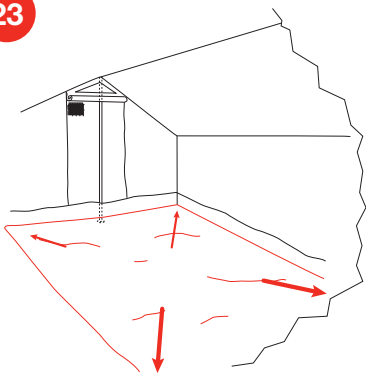

From inside the inner tent, flat ten the ground sheet, and adjust the general shape of the inner tent.

24

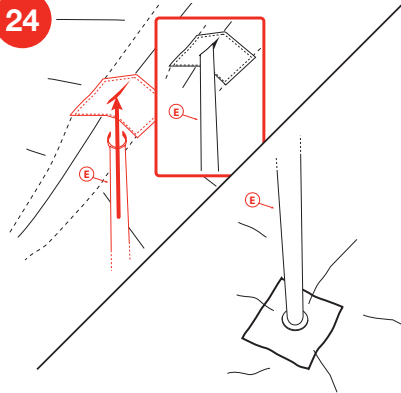

Place the central pole; make sure the base plate is located where the ground sheet is reinforced.

25

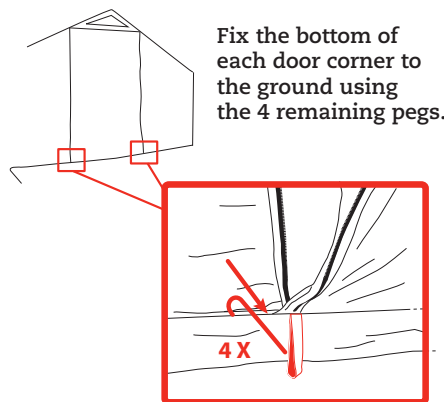

Fix the bottom of each door corner to the ground using the 4 remaining pegs.

26

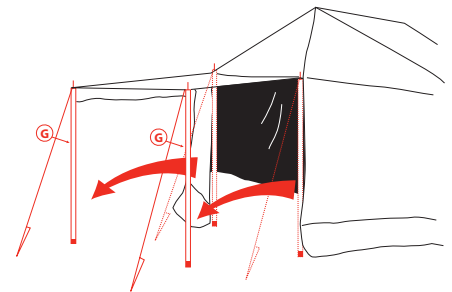

Outer tent doors can be used as awnings by moving the door poles, the door guy ropes and the pegs.



27

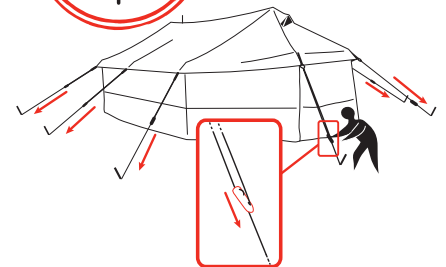

Check regularly the tensioning of the guy ropes and adjust if needed.



For more information on the IFRC shelter and settlements programme, please contact:

Graham Saunders
 Head, Shelter and Settlements Department
 E-mail: graham.saunders@ifrc.org
 Phone: +41 22 730 42 41
 Fax: +41 22 733 03 95

www.ifrc.org
 Saving lives, changing minds.

