

Safer Earth Building for Floods and Rains



Building Back Better



Choosing a Safe Place to build

Avoid flood risk areas - *Think about where the floods came to in the past and where the water flowed.*

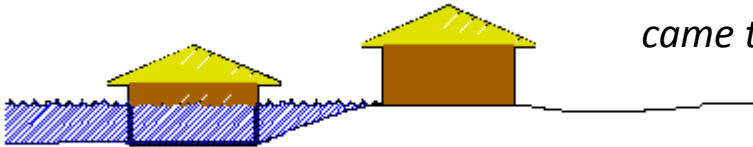

Avoid building near slopes- *Think about what may happen when it rains, especially landslides.*

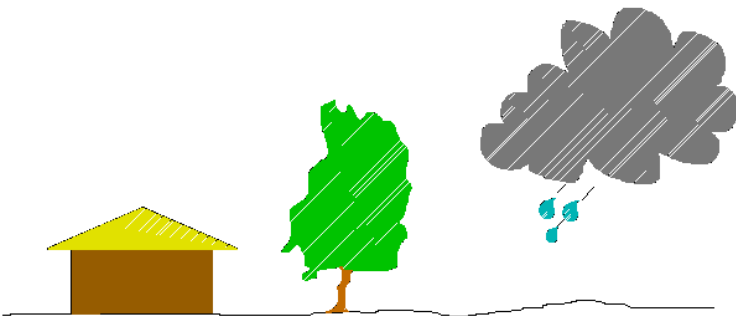
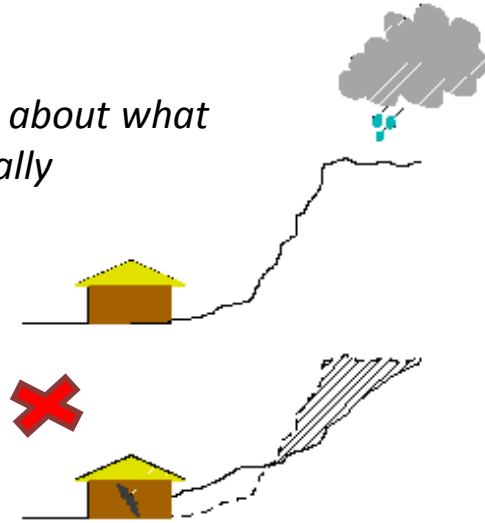

Natural Shelter – *Think about the direction of the wind and rain and find a sheltered site.*



Building Back Better



Where to build the latrine and kitchen

Keep kitchen far from the latrine

Kitchen

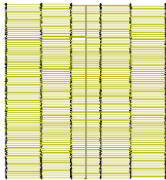

House

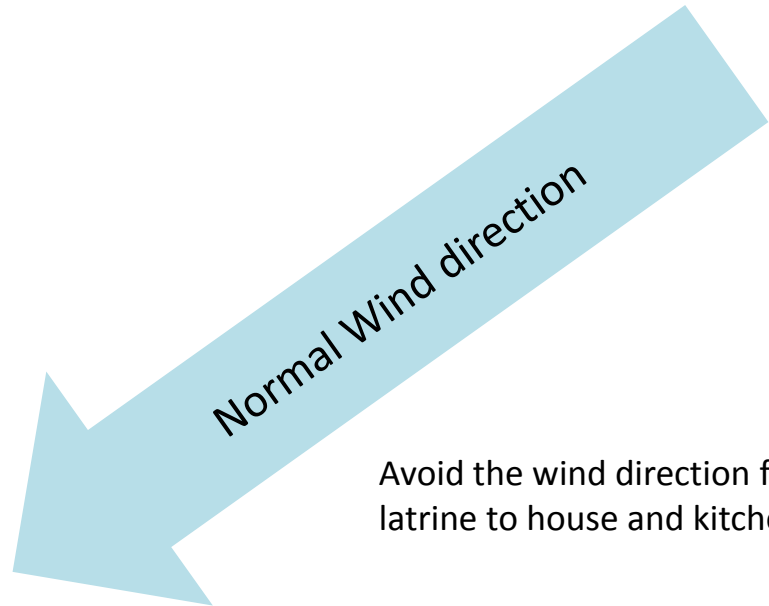
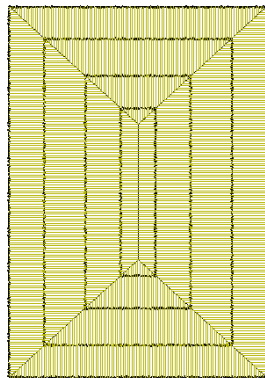

Avoid the wind direction from latrine to house and kitchen

Latrine should be 20m minimum from the house

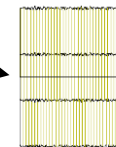

Latrine



Building Back Better



Foundations

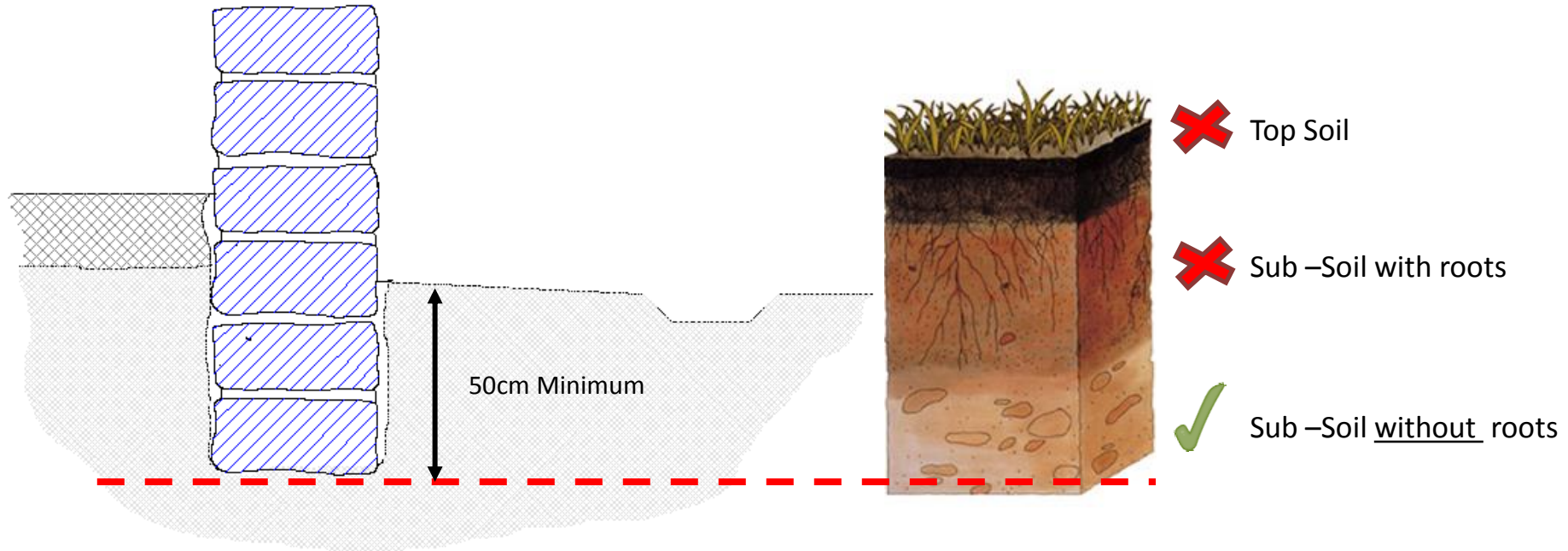

Foundations need to be at depth where the ground is firm and free of organic materials.

How high to build?



The floor level of the house should be 30cm (1 foot) above the height of any flood water



Building Back Better



How to build strong walls – The Golden Rules

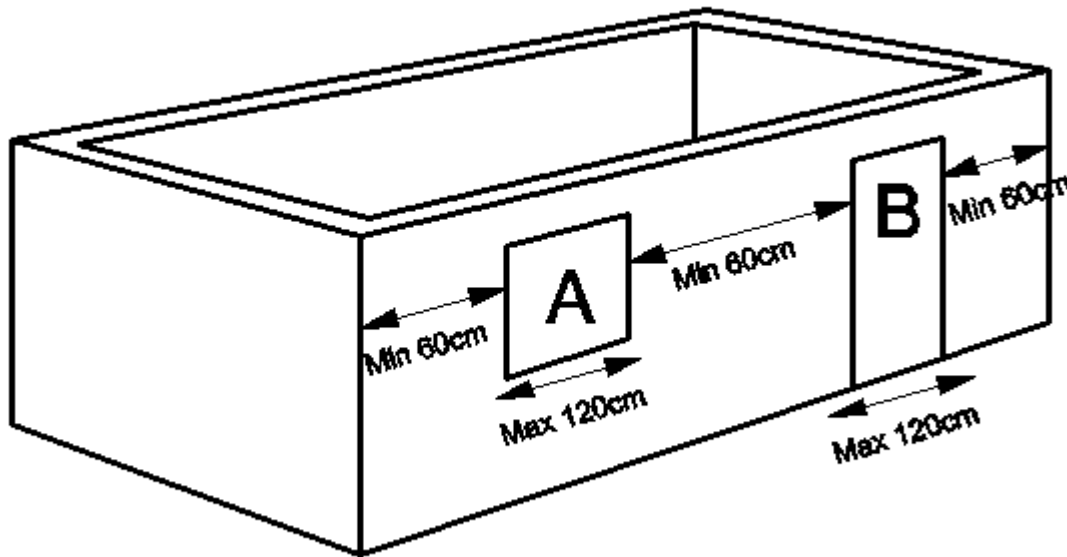

Rule 1

Doors and windows must be at least 60 cm (2 feet) from corners and other openings

Rule 2

Door and window openings should not be greater 120cm (4 feet)

Rule 3

The total area of openings must be less than 50% of the wall area.

$A+B =$ Less than 50% of the wall area



Building Back Better



Protecting walls

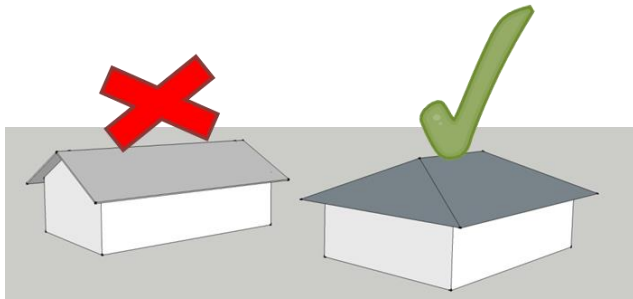

A covered veranda and hipped roof keep the rain off the walls, like traditional houses.

Making Good Earth Blocks



Soil test 1

- If it smells, it has too much organic matter
- If it is very gritty, then there is too much sand and is not good.
- If it is slimy and turns to fine dust as it dries, it has too much silt and is not good
- If it is sticky with some grit in it and does not smell then it may be the right type of soil.

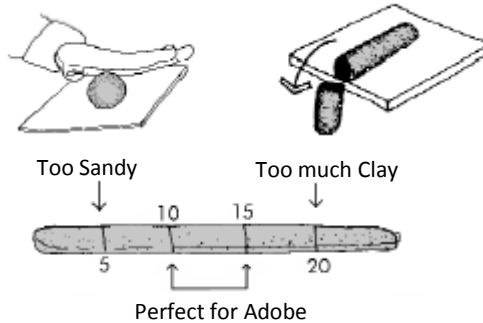

Soil test 2

- If the soil has too much clay you can add sand

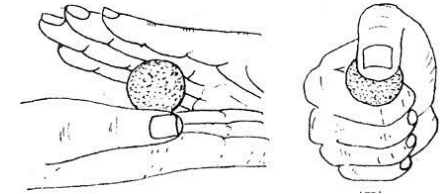

Soil test 3

- Roll 3 5cm Diameter balls of soil. Leave them in a shaded dry area for 1-2 days until they have dried.
- Try and crush between finger and thumb.
- If it crumbles into dust then it is not strong enough.
- If it breaks into large pieces, this is reasonable soil.
- If it cannot be broken, it is very good soil for earth blocks



Making Good Earth Blocks

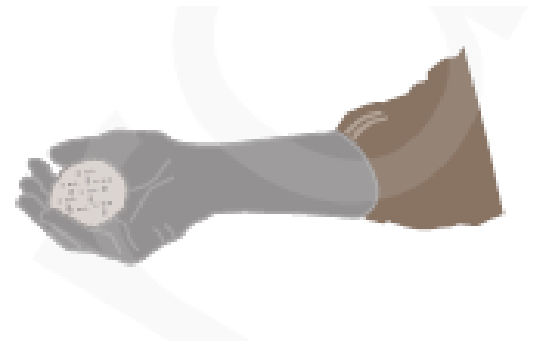

Too much water will make the blocks shrink and crack. Test by making a ball and roll between your hands. If it does not stick and stays in a ball, it is the right amount of water



Cover the blocks so that they dry slowly to avoid cracking

Mortar must use the same quality soil as the blocks



Building Back Better



Good Block Laying

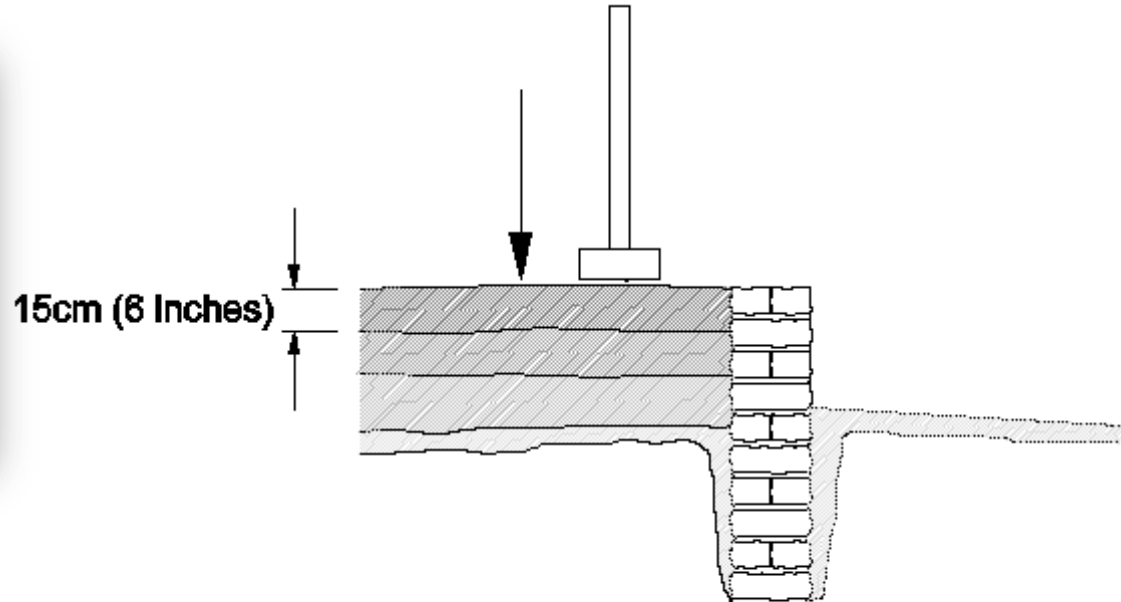

Fill all the joints properly

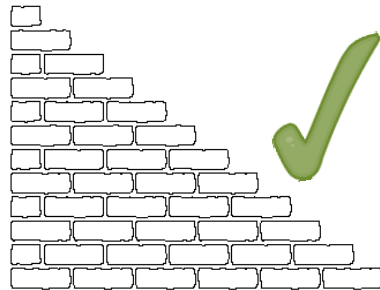
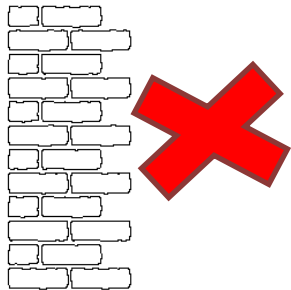

Fill the floor with the same type of soil used for the blocks. Fill and compact in 15cm layers

Construct walls using stepped corners



Building Back Better



Making a good roof

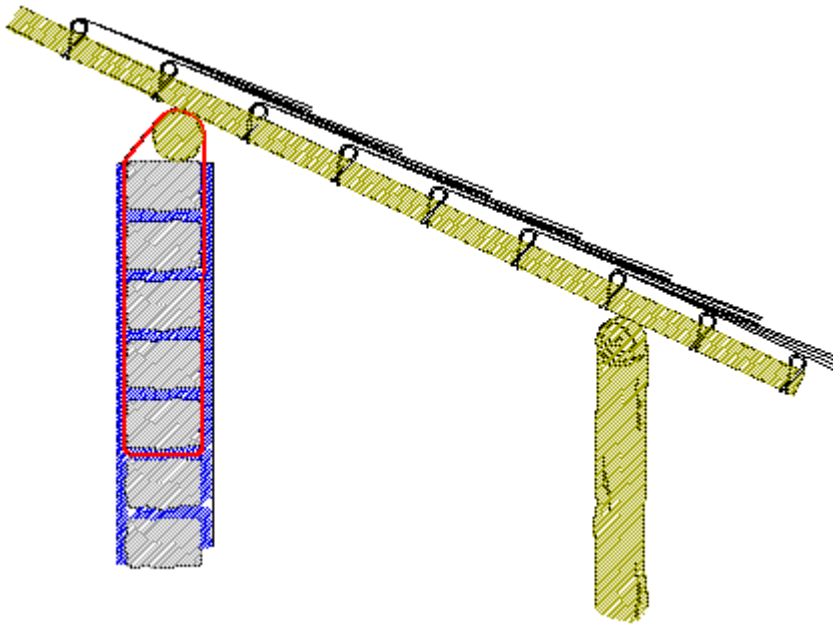

Poles that are fixed to the ground should be heat treated to prevent termites.

A wall plate must be fitted. If part of the walls collapse, this will support the roof until the wall can be repaired again.

The wall plate must be fixed to the wall with tie wire as shown

If you can afford it, fit a plastic membrane (plastic paper) before fixing the thatch

Protecting your house

Plant trees. This will provide shade, protection from wind and rain, stop soil erosion, and provide timber

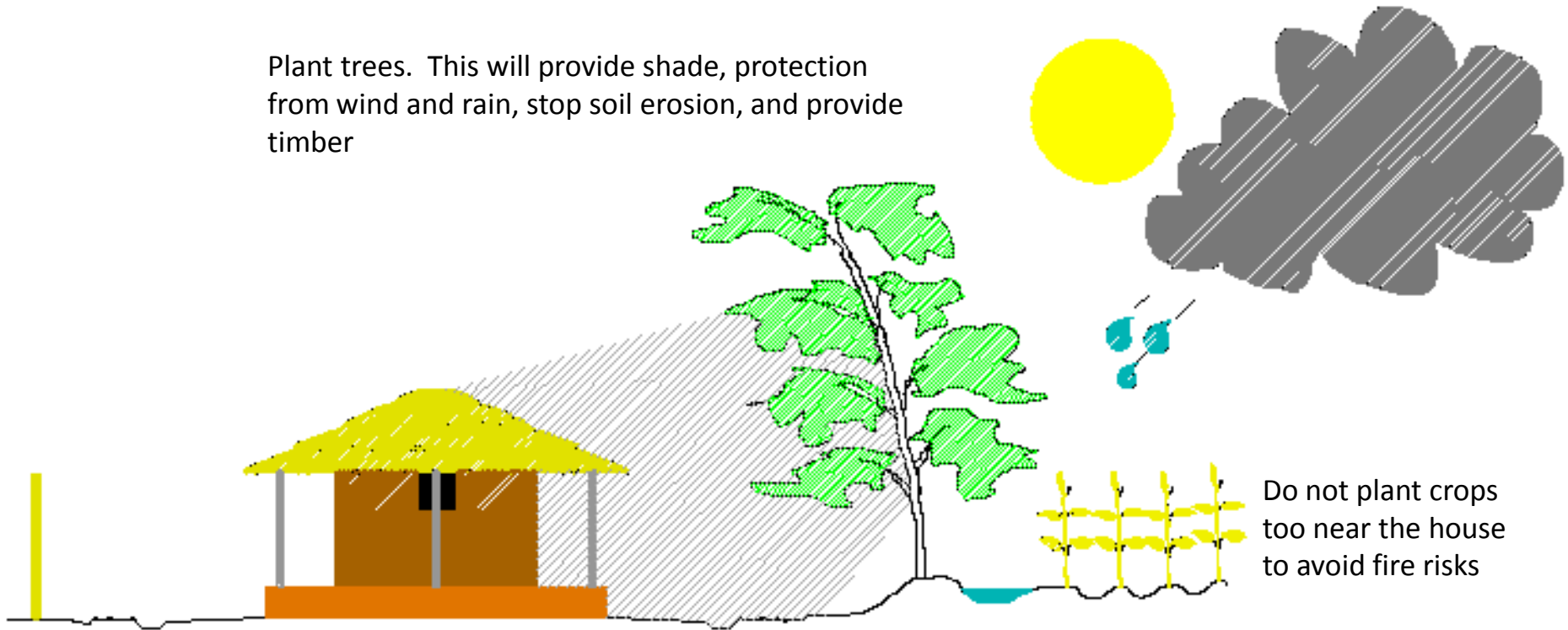

Build screens from bamboo and grass to protect the house from wind and rain

Build a bank with drains to stop water reaching the house

Do not plant crops too near the house to avoid fire risks



Building Back Better



Good Maintenance

Plant and care for the trees

Replace and repair thatch

Redo the render to walls and plinth

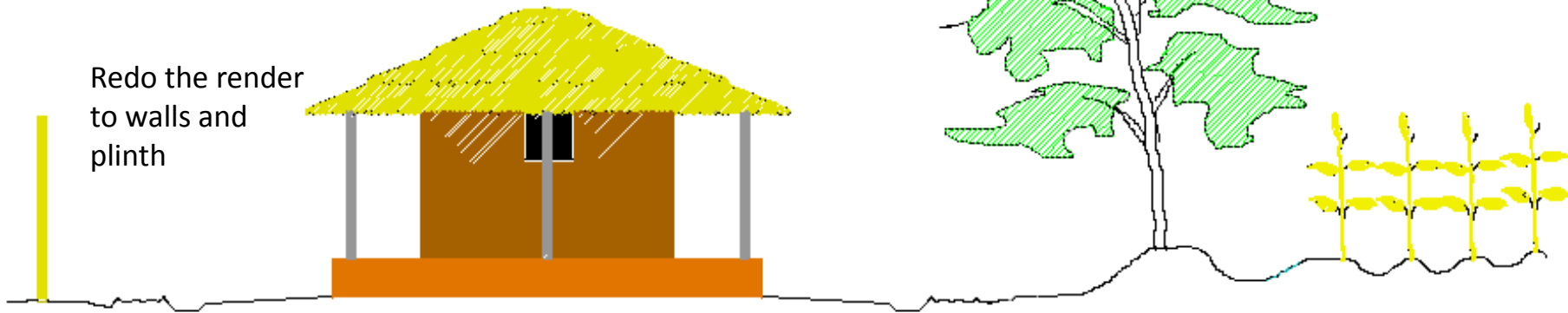

Maintain the ground level around the house so that the water drains away

Clean out the drains and maintain the banks



Building Back Better

