

General Accessibility Guidelines

Iraq - 2016



SUMMARY

I. GENERAL ACCESSIBILITY	2
What is Accessibility?	2
What is a barrier-free environment?	2
Who benefits from a barrier-free environment?	3
II. TECHNICAL ACCESSIBILITY GUIDELINES	4
1. How to REACH	4
A. PATHWAYS	4
➤ General Pathway Guidelines	4
➤ Wheelchair Dimensions	5
➤ Space Allowance	5
2. How to ENTER	6
A. ENTRANCES	6
➤ Stairs	6
➤ Ramps	7
➤ Doors & Handles	11
➤ Doors Locks	12
3. How to USE	12
A. PUBLIC BUILDINGS	12
B. REACHING ZONES	13
C. ACCESSIBLE WASH FACILITIES	14
4. How to UNDERSTAND	19
A. GENERAL COMMUNICATION	19
B. SIGNAGE & COMMUNICATION	19
III.ACCESSIBILITY CONSIDERATIONS FOR PERSONS WITH DIFFERENT TYPES OF IMPAIRMENTS	20
A. Accessibility for Persons with Visual Impairments	20
B. Accessibility for Persons with Hearing Impairments	23
C. Accessibility for Persons with Intellectual Impairments	25
IV. GENERAL TIPS ON INTERACTING WITH PERSONS WITH DISABILITIES	26

I. GENERAL ACCESSIBILITY

Access to facilities is a right for all people, including those with temporary and permanent impairments such as injuries and disabilities, in order to fulfil their basic needs. Access to facilities should be promoted by physical and sensorial access as well as positive attitude towards encouraging persons with particular vulnerabilities to use accessible facilities.

In this document, general guidelines are provided to improve accessibility. Improving access, safety and use of the facilities will not only benefit people with disabilities but also other vulnerable groups such as children, pregnant women and elderly.

What is Accessibility?

The root of the word **ACCESSIBILITY** is derived from **ACCESS** which means "the possibility to go into, to enter place" which implies freedom of movement use in total safety, regardless of age, gender or impairments. Places which can be used by all, with **no obstacles**, with dignity and the highest possible levels of independence.

What is a barrier-free environment?

Barriers: is a general term used to describe events, circumstances, conditions, attitudes that **hinder a person with disabilities** to participate fully and effectively on an equal basis. There are two main types of barriers: social (such as attitudes, support from family and/or community, available services) and physical.

The most common types of physical barriers to accessibility are:

- Lack of paved roads and pathways with ideal width (ex: roads with mud, rocks and narrow pathways..etc.).
- Lack of ideal dimensions for rooms, toilets, and kitchen .etc).
- Lack of communication means like signage.

Universal Design (often called **Inclusive Design**) is a design approach which designs products, environments, programs, and services to be usable by **all persons**, to the greatest extent possible, without the need for adaptation or specialized design, while promoting self-reliance, independence and ease of living for persons with disabilities, older people and people without disabilities.

As such, a barrier-free environment allows everybody, irrespective of age, gender or physical ability, to access and make use of the built environment. This includes everything from hospitals, schools, mosques, public water facilities to private homes. By designing and implementing accessibility of public facilities and spaces and public / private constructions we can make an environment barrier free thus allowing independent, safe and easy access for everyone.

In an emergency context, ensuring access to the built environment is a crucial element in reducing the vulnerability and isolation of people with disabilities: architectural accessibility facilitates, amongst other areas of inclusion, people's chances to reach services and facilities.

Who benefits from a barrier-free environment?

EVERYBODY!

- Elderly
- Young children
- Wheelchair users and other persons with reduced mobility or using mobility aids
- People with visual and hearing impairments
- People with mental disorders
- Pregnant women
- Injured people
- Parents using strollers

II. TECHNICAL ACCESSIBILITY GUIDELINES

Four levels of accessibility (in order of importance) must be considered when designing or implementing accessible facilities or services (an area, site, WASH facilities, shelter, community space and/ or service):

- 1) How to **REACH**
- 2) How to **ENTER**
- 3) How to **USE**
- 4) How to **UNDERSTAND** instructions and information

Technical recommendations are provided below for each level of accessibility:

1. How to REACH

It is important to ensure that pathways between various areas (shelter, WASH facilities, public spaces and services in the community) are accessible to all individuals, including persons with disabilities.

A. PATHWAYS

➤ General Pathway Guidelines

Pathways should be wide, smooth and free of obstacles:

- Pathways should be 150 cm wide. The minimum width should be at least 90 cm
- Pathway should be smooth, firm and level and non-slippery : crushed (not large) gravel, or concrete
- Pathways should be accessible for wheelchairs and people using mobility aids (see figures below).
- Pathways should be free of all obstacles (rocks, bricks, etc.), including coverage of drainage systems and other open hazards (holes, pools of standing water, etc.)
- Pathways should be well illuminated during the day and night
- 200cm free from obstacle height

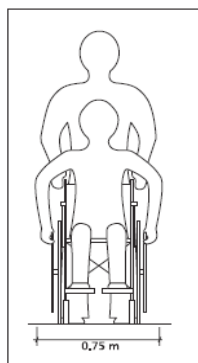

Single wheelchair user with assistant

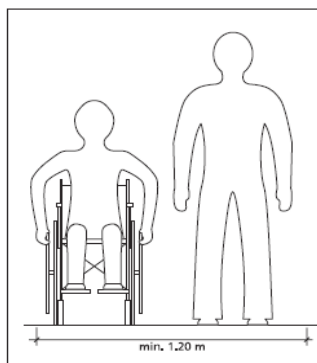

Ambulant person and independent wheelchair user

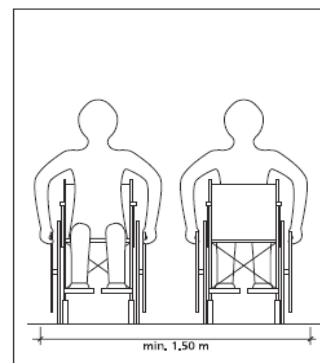

Two independent wheelchair users

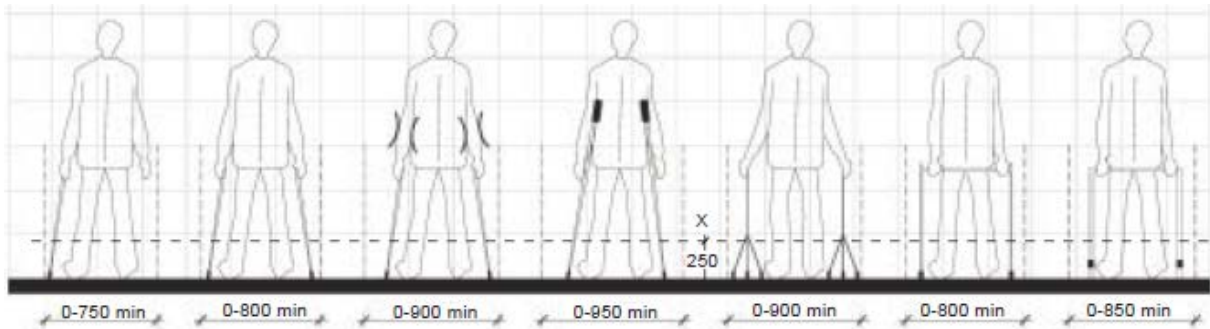

➤ Wheelchair Dimensions

Figures below show some of the typical dimensions of a standard wheelchair. Electric wheelchairs may be larger and cannot be maneuvered in the same way as manual wheelchairs.

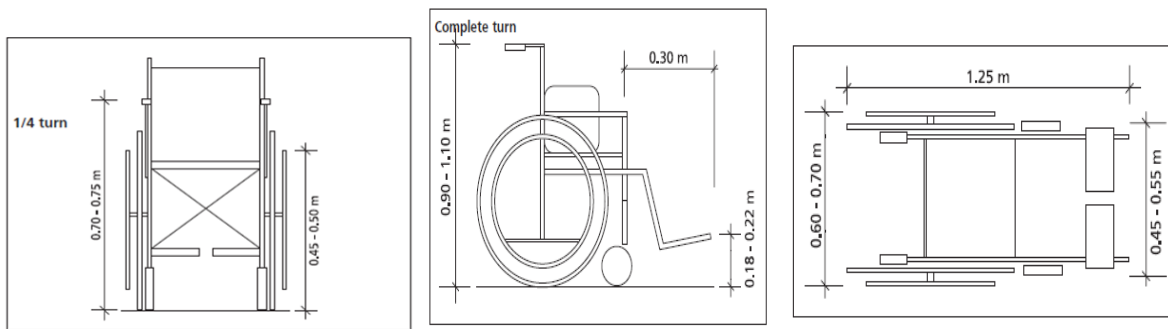

➤ Space Allowance

The **minimum** pathway width for **single wheelchair** should be **0.90m**

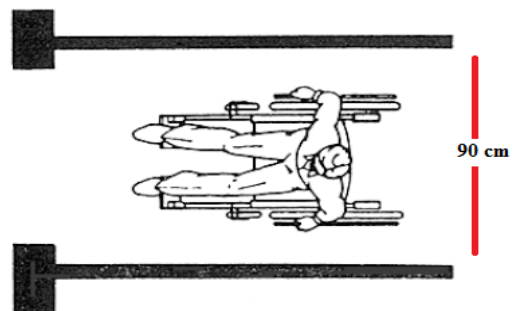

The **minimum** pathway width for **two wheelchairs** should be **1.50 m**

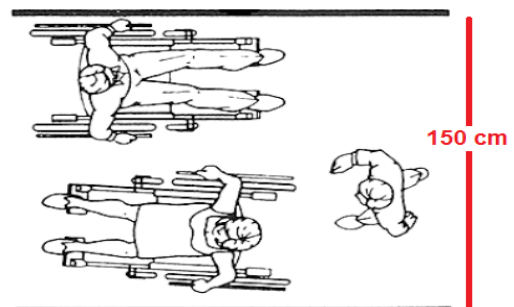

The space required for a wheelchair to make 180 degree turn in a T-shape space is 0.90 m in each pathway

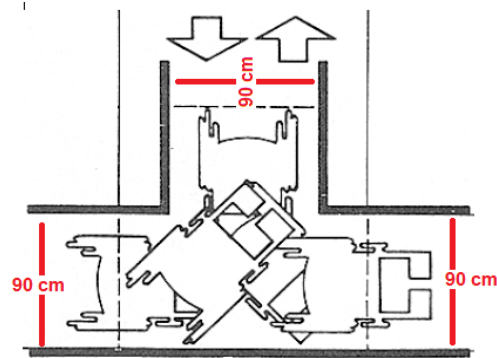

The space required for a wheelchair to make a 360 degree turn is 1.50 m * 1.50 m

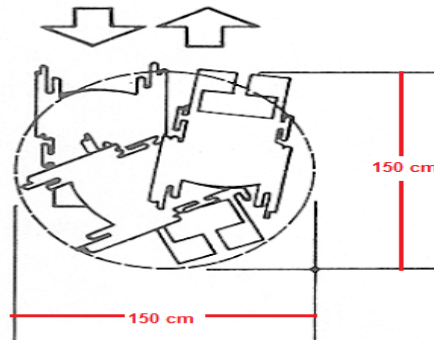

2. How to ENTER

Once the area or building (shelter, WASH facilities, public spaces and services in the community) has been reached, the entrance needs to be accessible to all persons, including those with mobility limitations including those using wheelchairs and mobility aids (see wheelchair dimension in the “how to reach section”), and those with vision impairment. This can be achieved by installing ramps and handrails, and ensuring that openings are wide enough for a wheelchair to pass through.

A. ENTRANCES

It is always preferable to have no steps at all and to have all entrances at ground level as this makes it possible for all persons, including persons using wheelchairs and persons using mobility aids, to enter and access the area. While it is preferable to have no stairs, in some cases stairs are possible. If stairs must be used, steps should meet the following specification:

➤ Stairs

- ✓ All the steps in a staircase should have the same dimensions
- ✓ Maximum 0.16 m in height
- ✓ Minimum 0.28 m in depth
- ✓ 1.00 m - 1.20 m in width
- ✓ If the staircase is more than 0.16 m, double handrails of different heights (70 and 90 cm high) should be provided for children and adults.
- ✓ Plan a landing/resting area every 10 steps and every time there is a direction change

- ✓ Install good slip resistance properties, particularly at the leading edge
- ✓ Mark the edges of the steps, dangerous areas and at the bottom and landing of each flight of stairs with a bright colors to prevent hazards – orange, yellow, green.
- ✓ Install handrails to help people with visual impairments to know the directions – e.g. forward, left or right

Note: See specifications of handrails under ramp specifications.

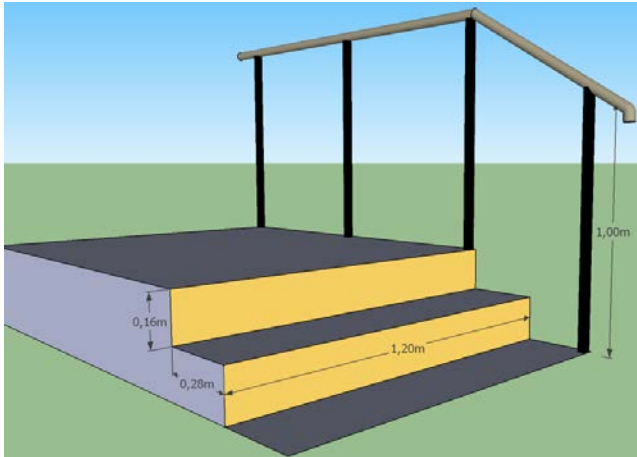

➤ Ramps

Ramps provide access to buildings and between different floor levels. Outside, ramps are usually the most practical way to provide wheelchair access between different levels.

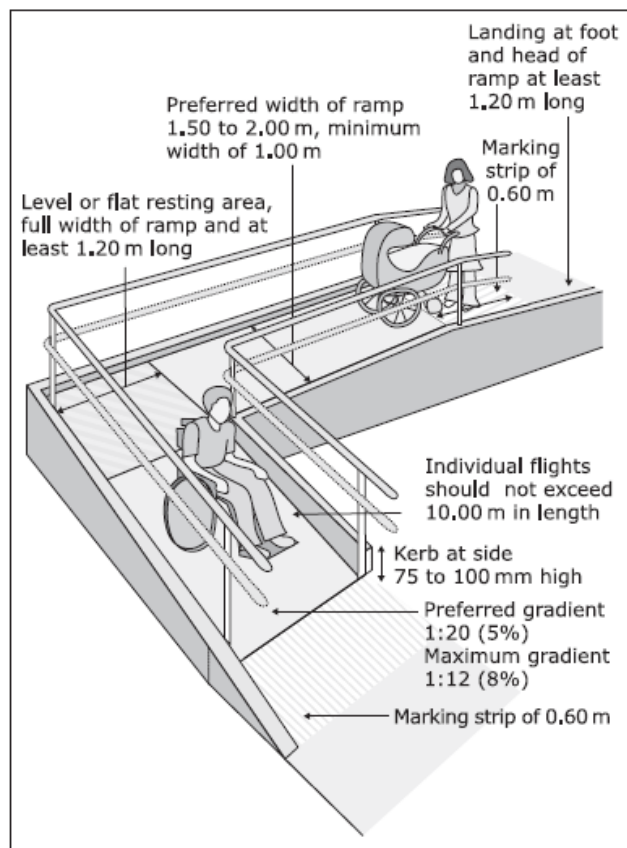

General Ramp Configuration:

There are three design options:

- 1) Straight run
- 2) 90 degree turn
- 3) Switch back or 180 degree turn

Ramp Width:

- ✓ The width of a ramp can vary according to use, configuration and slope
- ✓ The ramp should have a minimum width of 0.90 m => for straight ramps;
- ✓ Preferred width is 1.50 m to 2.00 m.
- ✓ For ramps requiring a landing space (when there is a change of direction), width should be 1.20 m minimum

Slope Specifications:

Having the correct slope is crucial as an overly steep slope can render a ramp too dangerous and inaccessible for an independent wheelchair user.

- ✓ Preferably there should be no vertical (very steep) slope at all.
- ✓ The preferred slope is 5% (1cm height :20cm length) and the maximum acceptable slope is 8% (1cm height : 12cm length)
- ✓ A slope of 12% is not ideal and only acceptable if it is for short distance (50 cm).

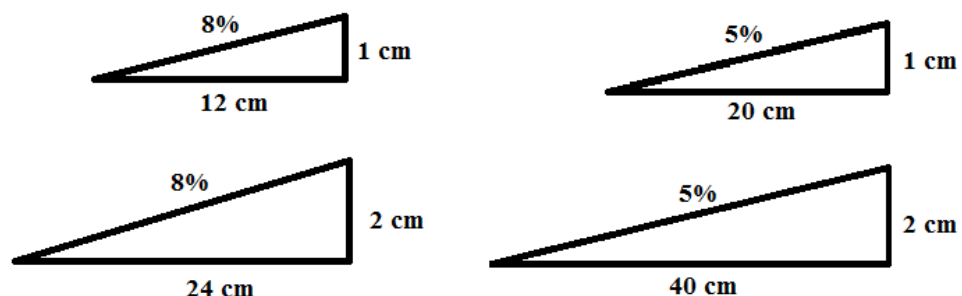

The table below is showing the maximum length and slope for a ramp.

Type	Slope	Maximum Length
Smooth Slope	<5%	12.00 m
Medium Slope	5% - 8%	6.00 m
Steep Slope	8% - 12%	3.00 m
Extra Steep Slope	12%	0.50 m

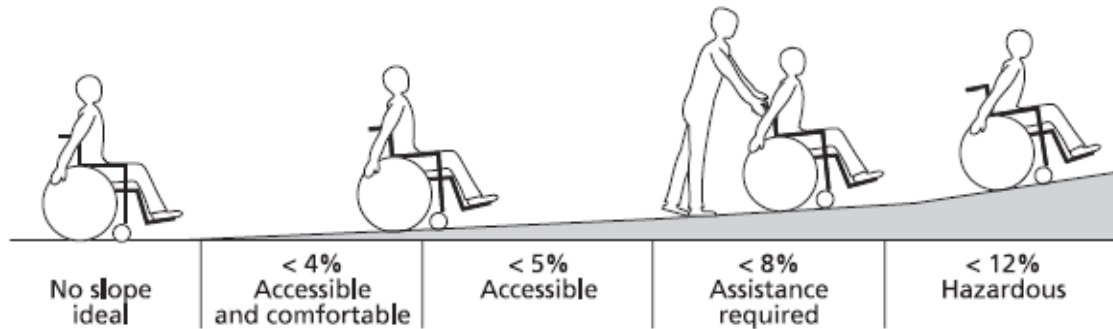

Landing space and resting area:

The steeper the slope, the shorter the distance that wheelchair users can cover without resting, therefore, landings should be provided for resting, maneuvering and avoiding excessive speed.

- ✓ Ramps require a landing space at the top, bottom and anytime the ramp changes direction.
- ✓ If the ramp is longer than 6.00 m or with a change of direction, it needs a resting area or landing space at least (1.20 m × 1.20 cm) in order to allow the user to take a breath

Surface:

- ✓ Should be firm not slippery, with tactile surface and contrasting color upstairs and downstairs for person with a visual impairment.

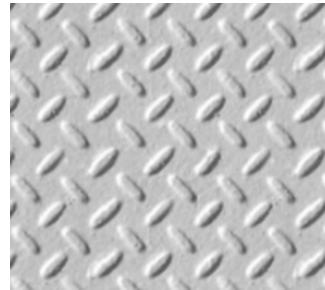

Handrails:

- ✓ For ramp with raise than 0.15 m, handrails should be provided:
 - On both sides of the ramp
 - At height of 0.90 -1.00 m from ramp level
 - Additional handrail at height 0.60 m – 0.70 m for children
 - 0.035 – 0.05 m in width and 0.04 m away from the wall
 - For ramps wider than 3.00 m, an intermediate handrail could be installed
 - Handrails must extend horizontally 0.30 m minimum beyond the top and bottom of stairs and ramps either returning to the wall or with a positive end that does not obstruct the pathway

- ✓ For ramp with rise less than 0.15 m no need to add handrails but **Edge Protection** should be provided at 0.05 m height from ramp level.

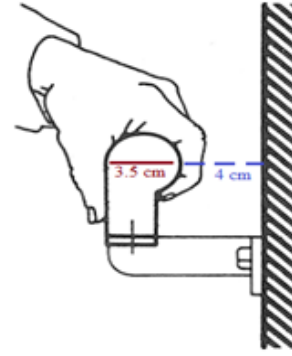
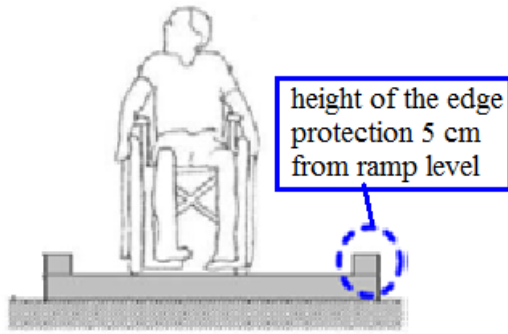

Handrail

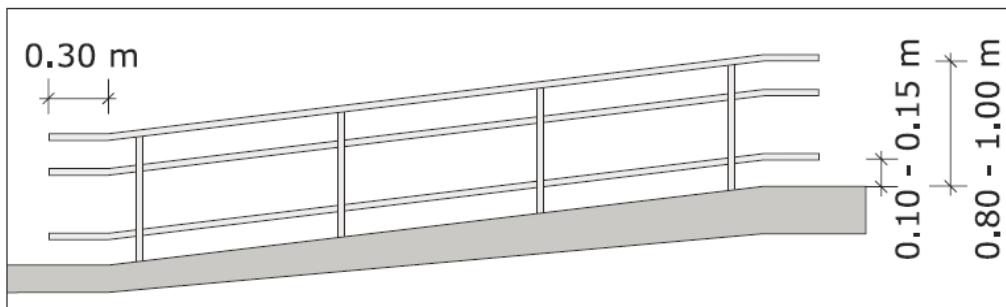
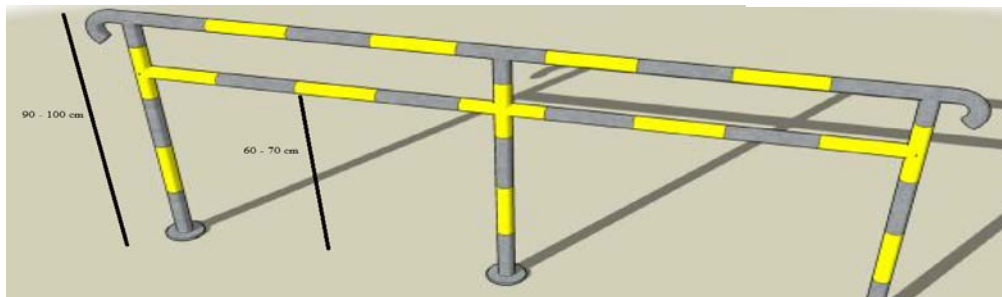

© R.Shikwana / Handicap International: Almasella Women's Center in Kawergosik Refugee Camp



© R.Shikwana / Handicap International: Handicap International Fixed Pointed in Qushtapa Refugee Camp

➤ Doors & Handles

- ✓ Door width should be minimum 0.90m (not including frame)
- ✓ Door should open outwards to increase usable space inside but make sure you have enough space for the door to open completely to the outside.
- ✓ Door handle should be easy to use (no round handle) and positioned at 0.80 m – 0.90 m height for children, wheelchair users and people of small stature

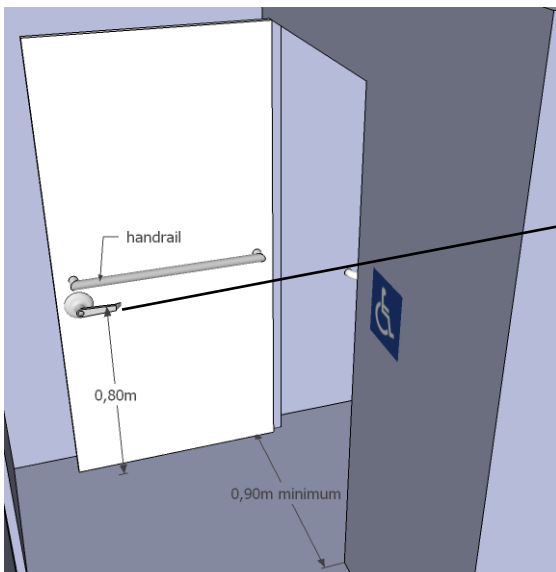

➤ Doors Locks

- ✓ Door locks should be under the handle
- ✓ Door locks should be also easy to handle for people with gripping problems. An adaptation of the handle could be done on the existing locks or a flip down lock system can be installed



3. How to USE

Once the person has reached and entered the building (shelter, WASH facilities, public spaces and services in the community), it is essential that the individual can use the different furniture/functionalities as well as is allowed to circulate within the building (corridor, room, between furniture...) this can be achieved by ...

A. PUBLIC BUILDINGS

SCHOOLS:

- Classrooms to be located in the ground floor.
- Gender separation (according to the cultural traditions of the area), ex: wash facilities; make sure to install at least one accessible latrine for girls and one for boys.
- Enough lighting of the public building.
- Use at least two communication means inside the class, auditory and visual to make sure that students with different type of impairments are able to understand participate.
- Make sure that in your design, accessible spaces for vocational activities are taken in consideration to build the capacity of the students.
- Take in consideration the stationary used in schools for writing, drawing



- Playground and outdoor activities should be accessible to different type of impairments, to encourage all students to participate in sports and different type of outdoor activities.

HOSPITALS/ HEALTH CENTERS/CLINICS:

- Take in consideration gender separation in waiting rooms/ wash facilities.
- Gender balanced staff are preferred for both medical and administrative staff to receive beneficiaries.
- In your design, take in consideration gardens and relaxation spaces.
- It is preferred to have a friendly space for children to stay during the waiting period.

GENERAL CONSIDERATIONS FOR PUBLIC BUILDINGS:

- **Fear of safety/new people:** In public places we you need to meet someone, try to meet him with one of his family members or friend present.
- **Space issues** (claustrophobia): When designing a public building take in consideration the dimensions of the rooms, it is preferable to have a large space to meet people.
- **Fear of getting lost:** Always try to meet people in a location where it is easier for them to enter and exit the place.

B. REACHING ZONES

The reach of a wheelchair user is constrained by his seated position and the wheels of the chair and the footrest extension limit access to room corners, window opening, workbenches or switches. It is also important to consider various reaching zones for children and persons of small stature.

It is also important to use accessible furniture such as kitchen, table, bed, which is not only a matter of reaching but really using the equipment;

- free space between furniture: 1.5 m to circulate
- free space under table, kitchen cooking table, counter, oven :
 - Height of furniture should be 0.8 m with a 0.7 m free space for legs below the surface
 - depth 0.6 m
- bench / bed: height above 0.45 m

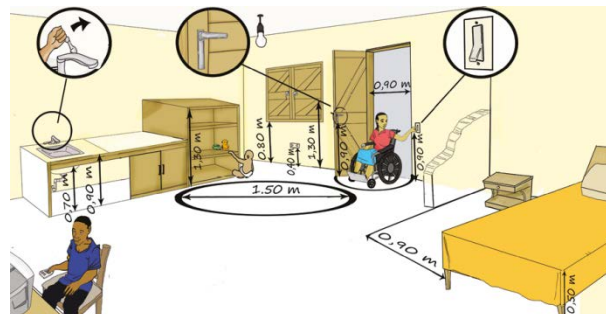

Vertical Reaching Zone

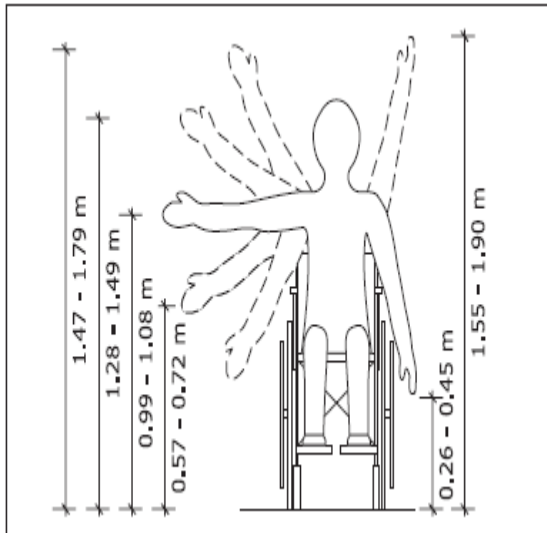

Horizontal Forward Reach

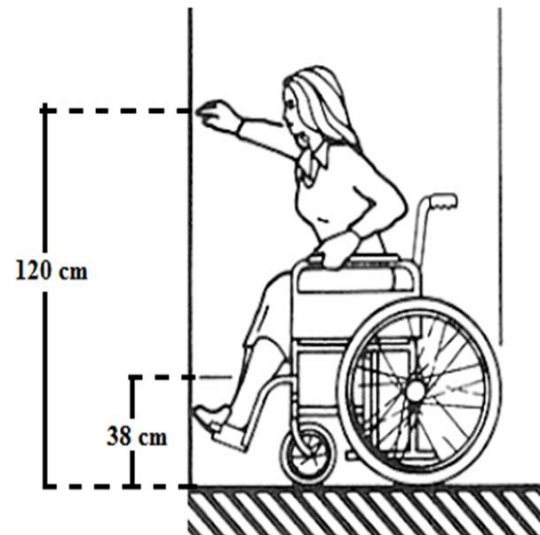
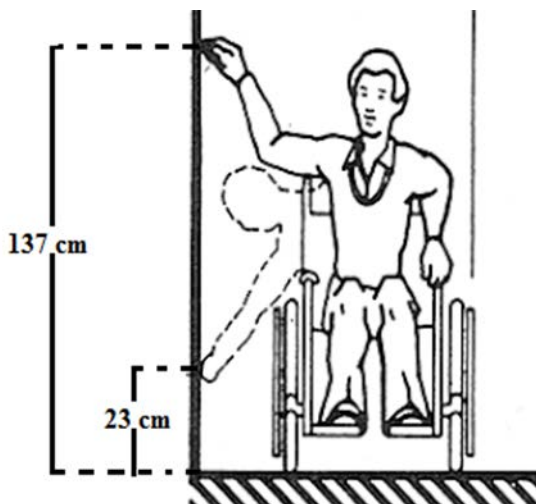
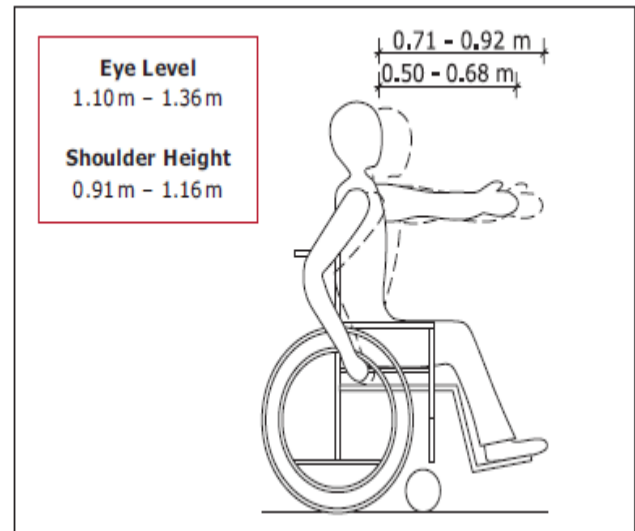

C. ACCESSIBLE WASH FACILITIES

Crucial for the design of an accessible toilet or wash closet is the provision of sufficient space for wheelchair users or people using other equipment, the installment of easy-to-use amenities at a convenient height and the provision of adequate handrails and grab bars to assist people moving from a wheelchair or people with reduced strength.

Generally, there are 3 types of approaches for wheelchair users to use the toilet: diagonal approach, perpendicular approach and parallel approach. To ensure the easy transfer from a wheelchair to the toilet seat, water closets (WC) or latrines should allow for a **parallel approach** as it proves to be the easiest.

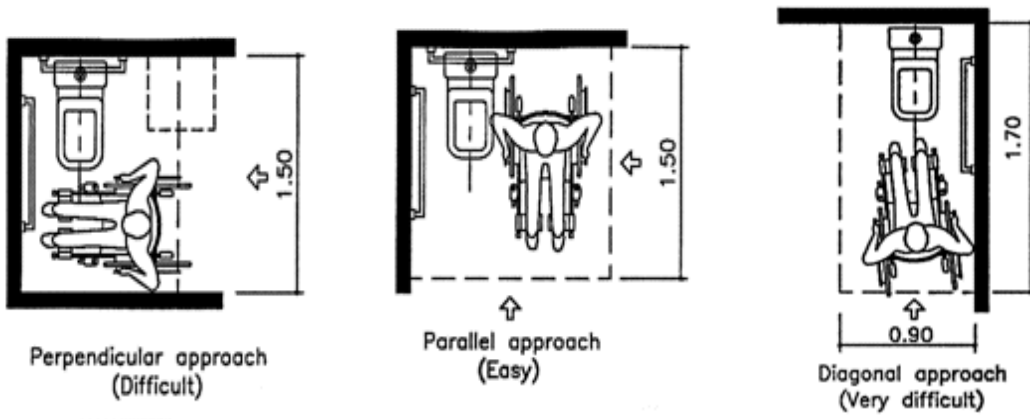

➤ **Toilet (Water Closet) Dimensions**

Dimensions of a Water Closet (WC) with Toilet Only:

- The minimal dimensions are **1.50 m X 1.50 m** for a WC containing only a toilet (no sink). If a sink or shower is required, the inside space of the cubicle needs to be increased (see below).

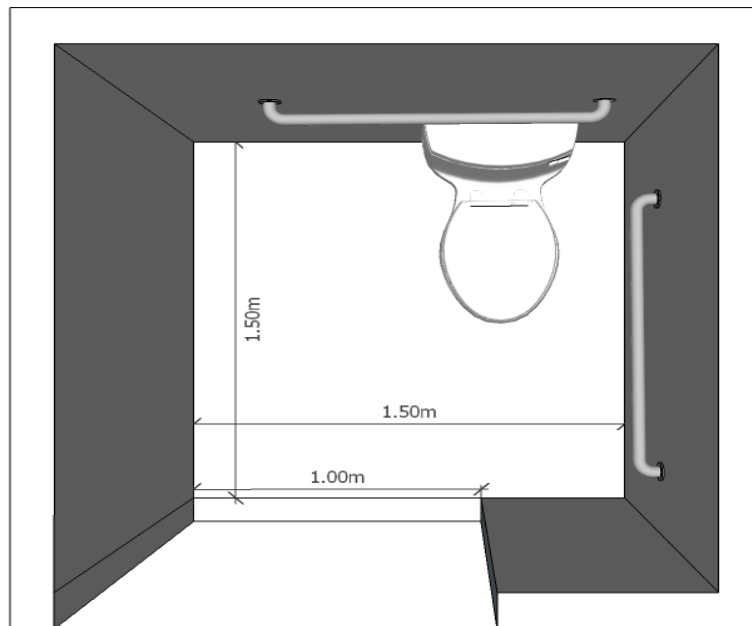

Dimensions of a Water Closet (WC) with Toilet & Sink:

- The ideal dimensions of an accessible WC with a toilet and sink is **2.00 m X 2.00 m or larger** (measured from the inside)
- The minimum cubicle space for a toilet and a sink is 1.50 m x 2.00 m

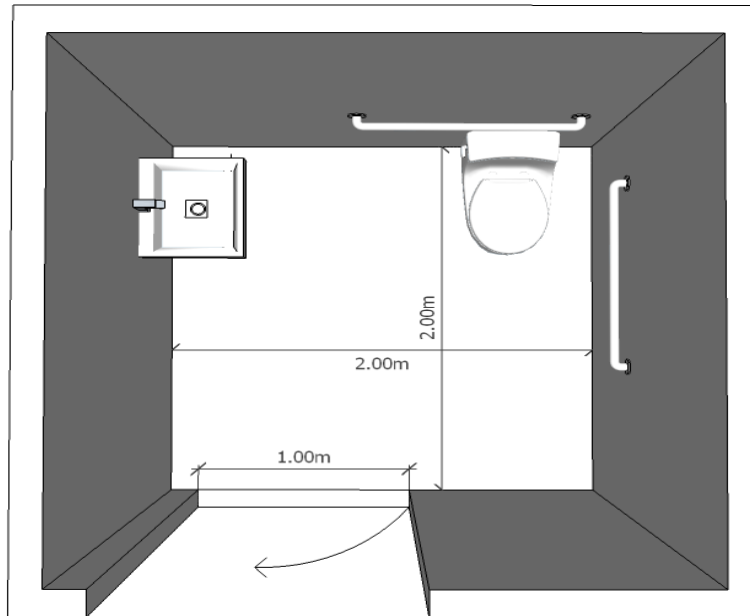

Dimensions of a Water Closet (WC) & Shower Unit:

- The minimum dimensions for a WC & shower unit is **1.50 m X 2.00 m**

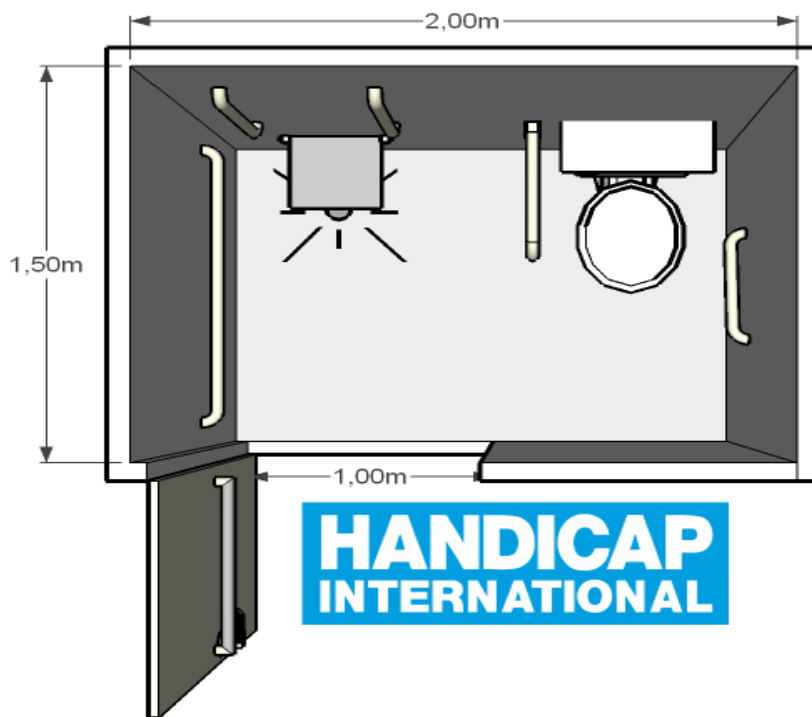

- Minimum cubicle space for a shower unit alone is **150 cm x 150 cm**. If a sink and/or toilet is required, the inside space of the cubicle needs to be increased as indicated above.

➤ Toilet Specifications

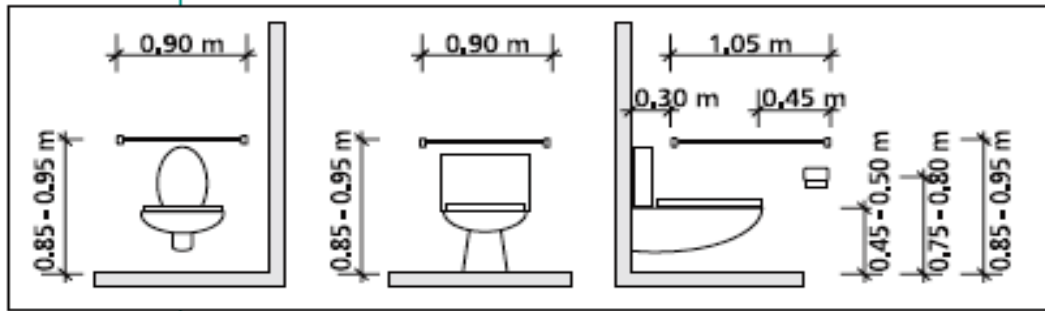

- ✓ **Wall-mounted toilet /WC recommended** (western style toilet)
- ✓ **Position:** Diagonally opposite corner to the door, 30 cm away from the wall
- ✓ **Toilet Seat Height:** 0.40 m to 0.50 m : which is equal to wheelchair seat height and facilitates transfers
- ✓ **Distance between the wall and toilet seat:** If the adjacent wall is provided with a grab bar, the distance between the center line of

the toilet seat and the wall should be between 0.45 m and 0.50 m to allow for easy reach of the bar

GRAB BARS: Generally, grab bars should be installed next to toilets, in showers and bath tubs to allow for the safe and easy use of the facilities by all people, including people with disabilities.

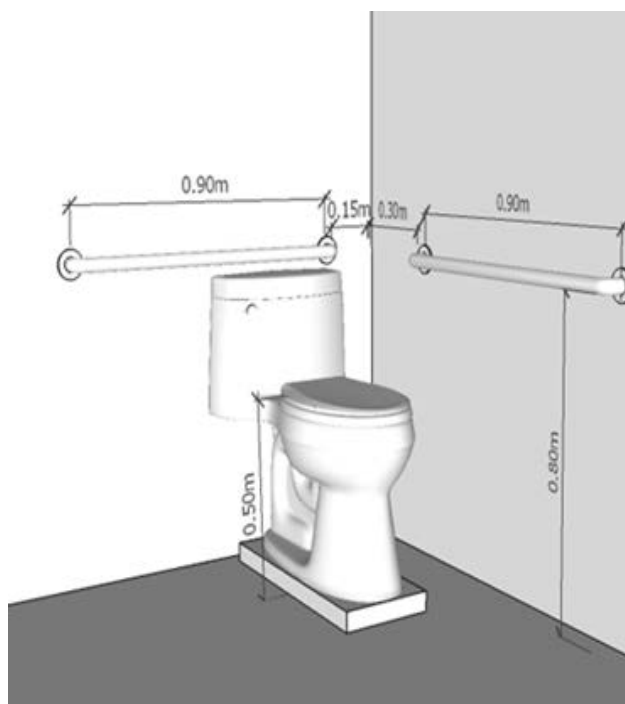

- ✓ Grab bars should be mounted at a height between 0.80 m and 0.95 m from the floor
- ✓ Grab bars should be approximately 0.90 m – 1.00 m in length
- ✓ In case of wall mounted grab bars, the distance between the rail and the wall should be 35 mm to 45 mm.
- ✓ Grab bars installed above toilet should be installed at 0.15 m away from the adjacent wall (see image)
- ✓ Grab bars beside the toilet should be installed at 0.30 m away from the adjacent wall (see image)
- ✓ Grab bars should be firmly fixed since considerable pressure will be placed on the rail.
- ✓ Grab bars should have a diameter of 30 mm to 40 mm

Note: If a grab bar is installed between the toilet and the open area, it needs to be ADJUSTABLE/MOVEABLE (see image on the right) and NOT FIXED. This facilitates transfers from the wheelchair to the toilet. If this is not possible, then the bar should be omitted. All other grab bars should be fixed.

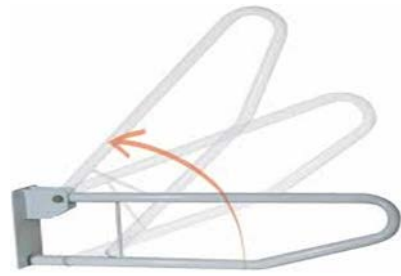

➤ Shower Specifications

- ✓ The dimensions of the cubical shower and the entrance (door) should follow the same dimensions as mentioned above.
- ✓ Shower bench: (0.50 m x 0.50 m minimum at a height of 0.50 m from the floor). The bench should be perforated with holes to allow water drainage. *A wider shower bench is ideal and safer.
- ✓ Grab bars should be installed on the wall besides shower bench at a height of 0.70 m - 0.80m
- ✓ Elevated shower head (telescopic shower head is ideal at height of 1.20 m).
- ✓ Handles should be easy to operate without rotating the wrist (using valve handle) at a height level of 0.90 m.
- ✓ No lips around shower (see image below)
- ✓ Floor surface should be non-slip, with a 2% slope in one part to allow water run-off.

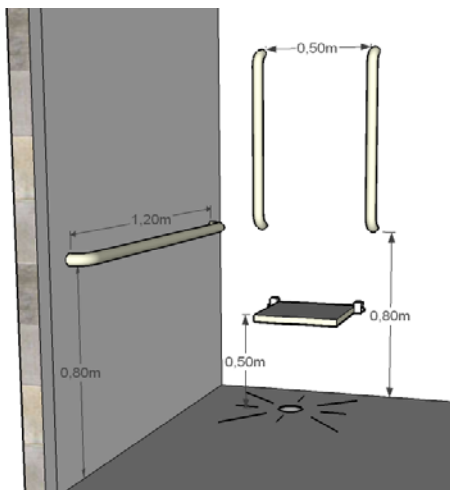

➤ Sink / Wash Basin Specifications

- ✓ The size of the sinks should measure approximately 0.45 m x 0.45 m
- ✓ Sinks should be located 0.15 m away from the wall- if the sink is near to a wall
- ✓ Sink height should be 0.80 m from the floor to the top of sink
- ✓ The clearance under the sink (from the floor to underneath of sink) should be 0.70 m to allow a wheelchair to roll under the sink
- ✓ Handles should be easy to operate without rotating the wrist (using valve handle) at a height of 0.90 m from the floor.

- ✓ A removable foot stool should be available for children and/or persons of small stature to access the sink

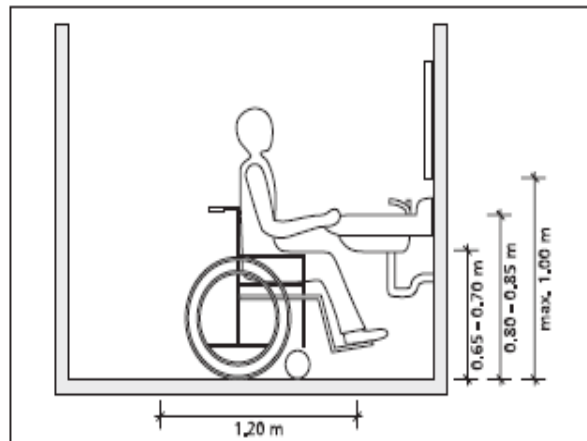

4. How to UNDERSTAND

A. GENERAL COMMUNICATION

Accessibility is ensuring that people with disability can access your communications and that there are no barriers that prevent this.

Making communication accessible means providing **alternative means** (formats or options) of communication. It is important to provide **at least 2 different means of communication** (verbal, visual, pictorial, auditory, etc).

An inclusive communication is designed to reach as broad and diverse an audience as possible with accessibility for different groups built in and part of the core communication. As such, it is important that inclusion is imbedded into every piece of communication and every communication campaign.

B. SIGNAGE & COMMUNICATION

➤ Signage organization

- ✓ Set up a logo/pictogram representing the nature of the service in the front of the facility entrance
- ✓ Signal important points (entrance, exit, information point, registration point, queue)
- ✓ Obstacles and dangers must be signaled
- ✓ Signage should be homogeneous throughout the space

➤ Signage positioning

- ✓ Use signage in the visual field (minimum : 0.90m / maximum : 1.80m)
- ✓ Set up signage off the pathway (avoid obstacles)
- ✓ Continuous signposting until the facility (no break of information, ensure continuity and consistency to avoid confusion)
- ✓ Set up signage at every decision point and at each change of direction
- ✓ Set up signage where there is good lighting or install lighting where you set up signage

➤ Signage format

- ✓ Use standard typeface (The best typefaces to use for signs and information are sans serif (e.g. Helvetica or Standard).
- ✓ The width-to-height ratio of letters, numbers and symbols on a sign should be between 3:5 and 1:1
- ✓ Use the appropriate sized letters according to the distance :

Maximum viewing distance	Letter size
30 m	52.0 cm - 104.0 cm
25 m	44.0 cm - 87.0 cm
20 m	35.0 cm - 70.0 cm
15 m	26.0 cm - 52.0 cm
10 m	17.0 cm - 35.0 cm
5 m	9.0 cm - 18.0 cm
2 m	3.5 cm - 7.0 cm
1 m	1.8 cm - 3.5 cm

- ✓ There should be a clear color contrast between the letters and the background for people with visual impairments. Black letters and logos on white background are preferable
- ✓ Keep texts simple. Avoid excessive information and where possible, aim for only one message
- ✓ Ensure all accessible facilities are clearly marked with large, simple accessibility symbols.
- ✓ Use universal pictograms in order to ensure comprehension by all



III. ACCESSIBILITY CONSIDERATIONS FOR PERSONS WITH DIFFERENT TYPES OF IMPAIRMENTS

It is important that accessibility modifications also take into considerations specific needs of persons with sensory impairments, including hearing and visual impairments. Some examples of accessibility modifications for persons with sensory and intellectual impairments are discussed below in this section.

A. Accessibility for Persons with Visual Impairments

Design considerations for person with visual impairment include the following elements, both for built environments and communication:

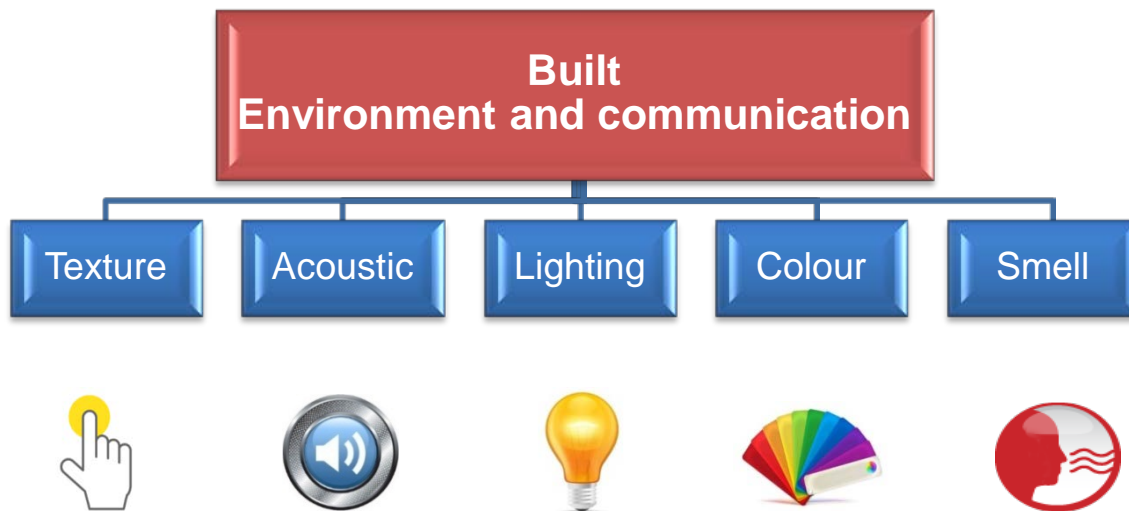

Texture

- Use guiding stripes on the ground, look for tiles with a typical surface and different color that can be felt by the sole of the foot to easily orientate and safely moving forward e.g., dotted tiles say “Stop or Turn”, lined tiles say “Go”.



- Make sure all accessible facilities are clearly marked with large, simple and international accessibility symbols.

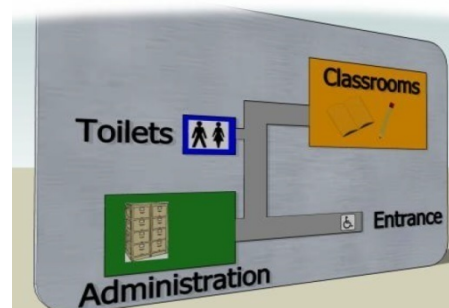

- Use the railing to show the directions inside the facility, for example; use a railing from the entrance of the WASH facility to lead the direction to the accessible toilet.



- Consider Braille for communicating written information

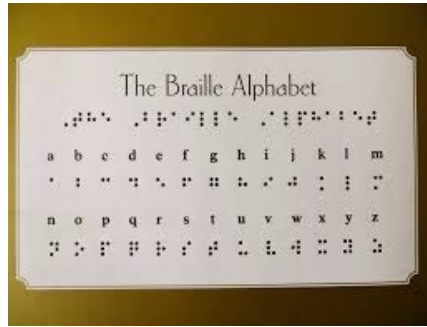

Acoustic

- Use Audio information (loud speakers, video). Sounds can assist in providing orientation clue about a space and used to spread your messages.
- Avoid noise sources around you when you spread messages or give orientations and directions.



Lighting

- Do not forget to light up signs at night and to ensure the light does not create shadows. Distribute the light level throughout different spaces.
- Avoid glare and reflections, which are often caused by shiny or glassy surfaces.

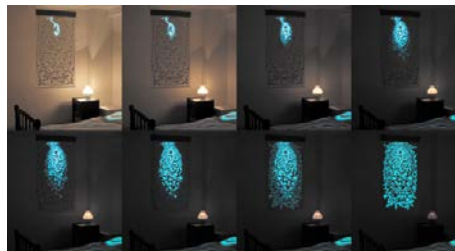
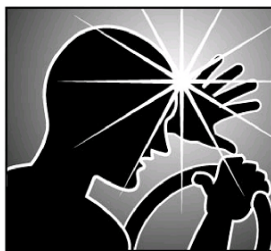

Color

- Write instructions with different size fonts and contrasting colors.
- Ensure that the stairs, edges, posts, pits, ropes and other dangerous areas are well marked with clear lines (bright colors where possible; yellow, orange, etc...).

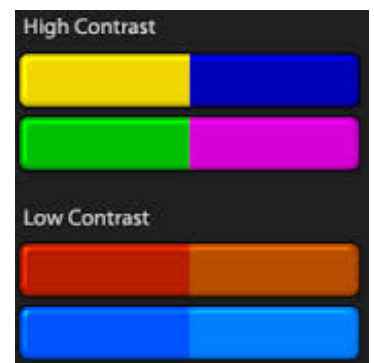

- Limit use of color and keep color schemes simple and avoid large-scale patterns. Keep in mind that too many colors used in design can create confusion.

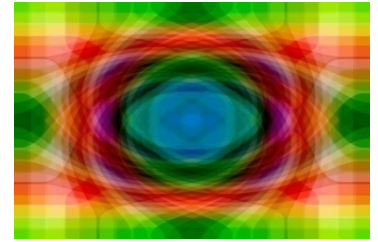

Smell

- Smells can assist in defining a space for person with visual impairment. Smells may be natural or artificial (e.g.: Use of natural flowers and artificial air freshener)

When you are talking to person with visual impairment remember:

- When meeting a person with a visual impairment, always identify yourself before you make physical contact with them;
- Ensure that the person with a visual impairment is standing at the front of the audience.
- Use verbal explanation more than visual demonstration or visual aids;
- Face the person with a visual impairment when talking with them;
- Always leave the conversation by saying or letting the person know that you are leaving.
- Use the tactile material to illustrate what you are talking about;
- Use accurate and speech language when giving direction, for example; “the door is on your left side rather than the door is over there”.

B. Accessibility for Persons with Hearing Impairments

Design considerations for person with hearing impairment include the following elements, both for built environments and communication:

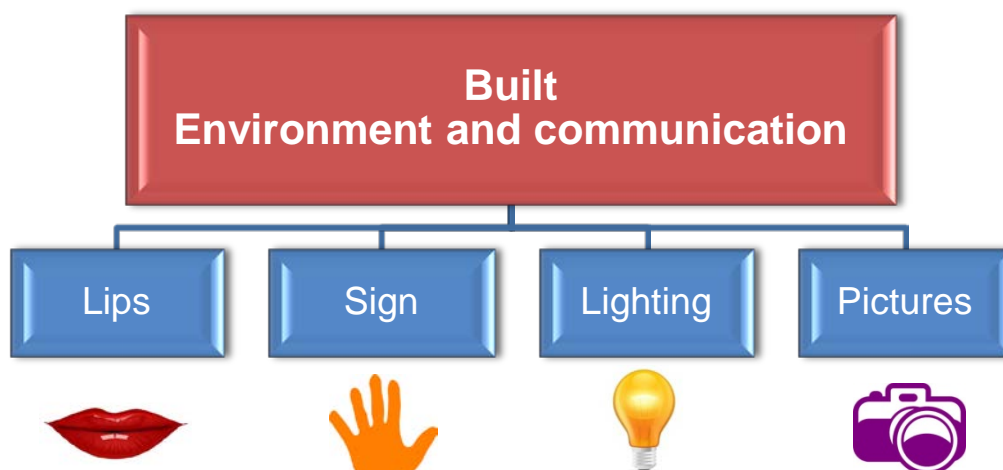

Lips

- Ensure that the person with a hearing impairment is standing near or in front of you, where he /she is more likely to be able to hear you or read your lips (if able to lip-read).
- Speak clearly and loudly, while at the same time maintaining normal mouth movement. Over stressing words in speech makes lip reading difficult.
- Rephrase, rather than repeat sentences that the person does not understand, over and over again.
- Reduce background voice from other people while you are talking or giving instruction.

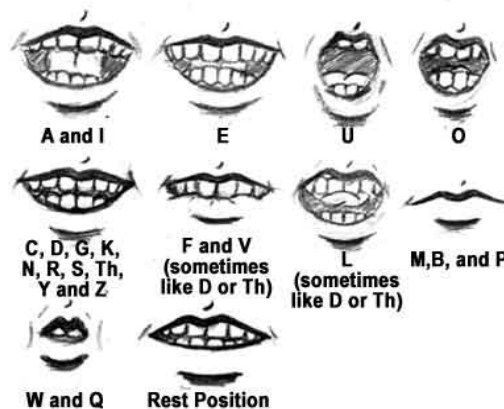

Sign

- Use sign language, seek interpretation support from a sign language interpreter if available or help from a family or friend who understands the person with a hearing impairment.
- Use facial expressions corresponding with the topic and mood of discussion.

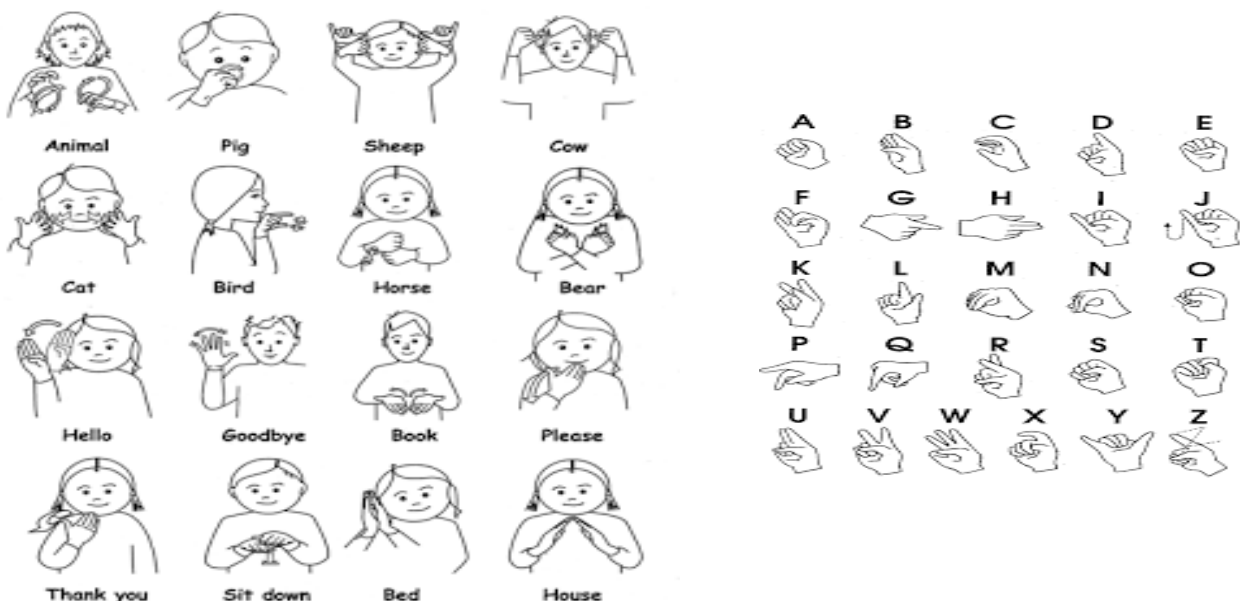

- Make and keep contact with the person and talk to the person and not to the interpreter, lip speaker or translator.
- Keep eye contact with the person, break eye contact will indicate that the conversation is over.



Light

- Use light to warn people if there is a change in the situation: fire, someone at the door, the phone is ringing etc.



Pictures

- Use gestures, demonstrations, written or pictorial instructions instead of only verbal instructions.

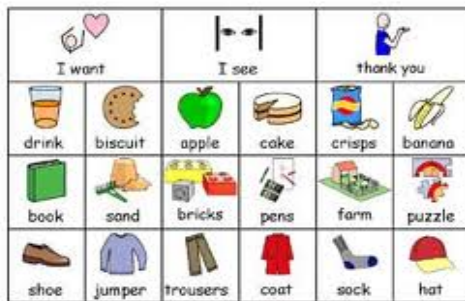

- Use visual aids to illustrate the directions, use simple pictures, international accessibility symbols and maps to show the directions inside and outside the facilities. Mark on the map the actual location of the person, to illustrate for him/her where he/she is and inform on the direction to take from this location.

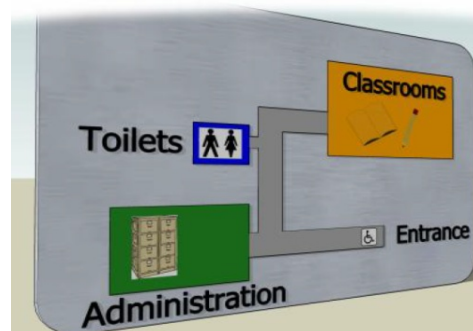

C. Accessibility for Persons with Intellectual Impairments

- ✓ Give clear, short, simple instructions and use simple language ensuring the explanation provided matches their level of understanding
- ✓ When giving instructions, stand in front of the individual to ensure they can hear and see you clearly

- ✓ Use wide range of communication methods: verbal instruction, visual demonstration and other visual and auditory inputs (pictures, noise-making toys)
- ✓ Repeat instructions frequently
- ✓ Use colourful images and equipment
- ✓ Be patient and allow extra time
- ✓ Break down the task into small steps or learning objectives

IV. GENERAL TIPS ON INTERACTING WITH PERSONS WITH DISABILITIES

➤ **Consult persons with disabilities**

Involve persons with disabilities in the decision making process and ask about their opinion. Consider them as the best expert about their disability/injury. It is best to always ask them for advice on how to best meet their needs.

➤ **Ask before you assist**

Don't assume all persons with disabilities need assistance as many people are able to function independently in their daily activities, including moving around. In the event they do require assistance, it's important to ask them how you can best support them before you initiate to do so.

➤ **Be sensitive about physical contact**

Respect their dignity = don't touch persons with disabilities without their permission. Don't grab or hold wheelchairs and other equipment they use without checking with them first.

➤ **Don't make assumptions**

Persons with disabilities are the best judge of what they can or can't do and of their needs. Don't assume their abilities or capacities by their appearance.

➤ **As much as possible speak directly to persons with disabilities**

Remember even if people can't speak, they can communicate in other ways. Be patient with persons with disabilities and do not treat them as if they will not understand.

➤ **Treat persons with disabilities with dignity**

Don't talk to a person with a disability through a third person and don't define them by their disability (e.g. "The amputee", "The blind"), use "person with amputation, person with difficulty seeing", etc.



Sources / References

- Christian Blind Mission (2005), *Promoting universal access to the built environment*, Bensheim, Germany
- Department of Justice (1994), *Excerpt from 28 CFR Part 36: ADA standards for accessible design*, United States of America
- Handicap international Ethiopia (2012) *Introduction to accessibility in a camp setting*
- Christian Blind Mission (2008) *Promoting Access to the Built Environment Guidelines*
- Handicap International Jordan (2014) *Basic Standards on Accessibility*
- Design manual for a barrier-free built environment (2014)
- Other Handicap International documents