

(For private circulation & training of J & K Engineers)

**GUIDELINES
FOR
EARTHQUAKE RESISTANT RECONSTRUCTION
AND
NEW CONSTRUCTION OF MASONRY BUILDINGS
IN
JAMMU & KASHMIR STATE**



By

Prof. Anand S. Arya

National Seismic Advisor

GoI – UNDP DRM Programme

**MINISTRY OF HOME AFFAIRS
GOVERNMENT OF INDIA**

October, 2005

PREFACE

The Earthquake: A strong earthquake of magnitude 7.4 occurred on 8th October 2005 at 9.20.38 AM (IST) with epicentre at 34.432°N, 73.537°E in Muzaffarabad Region of POK. The shaking caused massive destruction to houses, public buildings and communication network in Pakistan as well as Jammu & Kashmir.

The high intensity earthquake was felt across northern India covering states of Jammu & Kashmir, Uttaranchal, Delhi, and Punjab, Himachal Pradesh, Rajasthan, Haryana, and Uttar Pradesh at 9.25 a.m. (IST). The worst affected districts in Jammu and Kashmir due to impact of the high Magnitude earthquake are M blocks/districts of: Uri, Tangdhar, Poonch, Baramulla, Udhampur, Ramban, Kathua, Budgam, Anantnag, Pulwama, Kupwara, Srinagar and Jammu.

Damages in Jammu and Kashmir, India: Official reports confirm death of 1300 persons (Baramulla, Uri, Poonch, Udhampur and Kupwara, Srinagar districts), including 72 army personnel and death of one each in Gurdaspur and Batala districts in Punjab. 7510 people sustained injuries in Srinagar and Jammu divisions. 7 buildings were damaged in Amristar, Hoshiarpur, Moga, and Gurdaspur in Punjab state. Damage assessments: 37607 masonry buildings (houses, buildings) have collapsed; Srinagar division (31,809) and Jammu division (614).

Building Types: Most damaged/destroyed buildings in J & K were constructed using random rubble masonry and bricks laid in clay mud mortar. Most of them had corrugated galvanized iron sheet roofing. No earthquake resisting measures were used.

Such buildings are destroyed in a severe earthquake on account of weakness of the mortar used, absence of bond stones across the thickness of the stone wall resulting into delamination of the inner and outer walls, and separation of the walls at the corners. These finally result into the total collapse of the buildings.

Objective and Scope of the Guideline: In view of the decision by the State govt. that the survivors would reconstruct their homes using much of the available material from collapsed houses like stones, bricks, timber and CGI sheets, they must be constructed to be resistant to future earthquake shocks. These Guidelines detail out those earthquake resistant techniques and procedures for reconstruction and construction of new buildings using the available materials which will make them safe. Using good quality *cement mortar* in the construction of stone and brick masonry walls is one of the important requirements. However, if *mud mortar* is desired to be used for any reason, reasonable earthquake resistance can be achieved by using appropriate measures. The Guidelines, therefore, cover both '*masonry in mud mortar*' and '*masonry in cement mortar*'. Similarly seismic bands made of *reinforced concrete* or using available *wooden elements* are both covered. Also, use of *concrete blocks* (solid and/or hollow) may also be made laying the masonry in cement mortar.

It is hoped that the house owners and the supervising Engineers will take full care in using all necessary safety elements in the new construction whether for housing or for important buildings for Schools, Public health or Community congregations.

New Delhi
Oct, 19, 2005

A. S. Arya
National Seismic Advisor
Ministry of Home Affairs
Gol-UNDP DRM Programme

CONTENTS

PREFACE	2
CONTENTS	3
EARTHQUAKE RESISTANT CONSTRUCTION OF STONE BUILDINGS	5
1. INTRODUCTION	5
2. OBJECTIVES OF THE GUIDE	5
3. SCOPE OF THE GUIDE	5
4. OPTIONS FOR WALL TYPES	6
5. OPTIONS FOR ROOF AND FLOOR TYPES	7
6. REQUIRED EARTHQUAKE SAFETY PROVISIONS	7
6.1 Building Categorization	7
6.2 Measures for Achieving Seismic Safety	7
7 SITING AND FOUNDATIONS	8
7.1 New Foundations	8
7.2 Use of Existing Old Foundation	9
8 TREATMENT AT PLINTH LEVEL	9
9 STONE MASONRY WALLS IN MUD MORTAR	10
9.1 Construction Control	10
9.2 Control on Wall Length and Building Height	10
9.3 Control of Openings in Bearing Walls	11
9.4 Seismic Bands	12
9.5 Vertical reinforcement at corners	14
9.6 Water Proofing	15
10 STONE MASONRY USING CEMENT MORTAR	16
10.1 Construction Control	16
10.2 Control on Wall Length and Building Height	16
10.3 Control on Openings in Bearing Walls	18
10.4 Seismic Bands	19
10.5 Vertical Reinforcing bars in walls	21
10.6 Vertical Reinforcement at Jambs of Openings	23
11 MASONRY WALLS WITH BRICK	24
11.1 Essential elements for earthquake safety	24
11.2 Good cement mortar	24
11.3 Opening in bearing walls	24

11.4	Seismic bands	25
11.5	Vertical reinforcement in the brick walls	26
12	MASONRY WALLS WITH CONCRETE BLOCKS	28
12.1	Concrete Block Masonry	28
12.2	Use of Solid Concrete Blocks	28
12.3	Use of Hollow Concrete or Micro Concrete Blocks	29
12.4	Use of Mortar	29
12.5	Control on Wall Height & Length of Rooms	29
12.6	Control on Door/Window Openings	29
12.7	Seismic Bands	29
12.8	Vertical reinforcing Bars	29
13	WOOD FRAMED WALLS	31
13.1	Foundations	31
13.2	Types of framing	32
14	ROOF	35
14.1	Sloping wooden roofs	35
14.2	Roof structure	35

EARTHQUAKE RESISTANT CONSTRUCTION OF STONE BUILDINGS IN EARTHQUAKE AFFECTED AREAS OF JAMMU & KASHMIR

1. INTRODUCTION

These guidelines have been specially framed for the reconstruction of collapsed or severely damaged houses in the various affected areas of Jammu & Kashmir and also construction of new houses in these areas. The guidelines will also be helpful in earthquake resistant construction of houses in other parts of the State and the other States which fall in seismic Zones IV and V of the Seismic Zoning Map of India.

2. OBJECTIVES OF THE GUIDE

The main objective of these guidelines is to illustrate the earthquake resisting construction measures in accordance with the Seismic Zoning Map of Jammu & Kashmir using the building construction standards adopted in India, namely, IS: 4326 and IS: 13828 of 1993.

According to Seismic Zoning Map of India there are the following seismic zones in Jammu & Kashmir (Fig.2.1)

Zone V : MSK Intensity IX or higher is probable to occur.

Zone IV : MSK Intensity VIII is probable here

The recommendations contained herein are based on these probable Intensities for the design of buildings according to the Codes. Reconstruction and new construction of buildings will be safe if it would be in accordance with the specified Intensities.

3. SCOPE OF THE GUIDE

These guidelines cover those houses which are situated in the earthquake prone zones and whose bearing walls are built using coursed stone masonry or brick work, or concrete block work and do not exceed 7.0 meters in length in any room and the number of storeys are no more than two. The roof can be flat or sloping. The earthquake resistant provisions are indicated for seismic Intensities $MSK \geq IX$, and VIII as appropriate for the earthquake damage prone Zones V, and IV respectively. Construction of walls using *mud mortar* as well as cement mortars is dealt in this Guide.

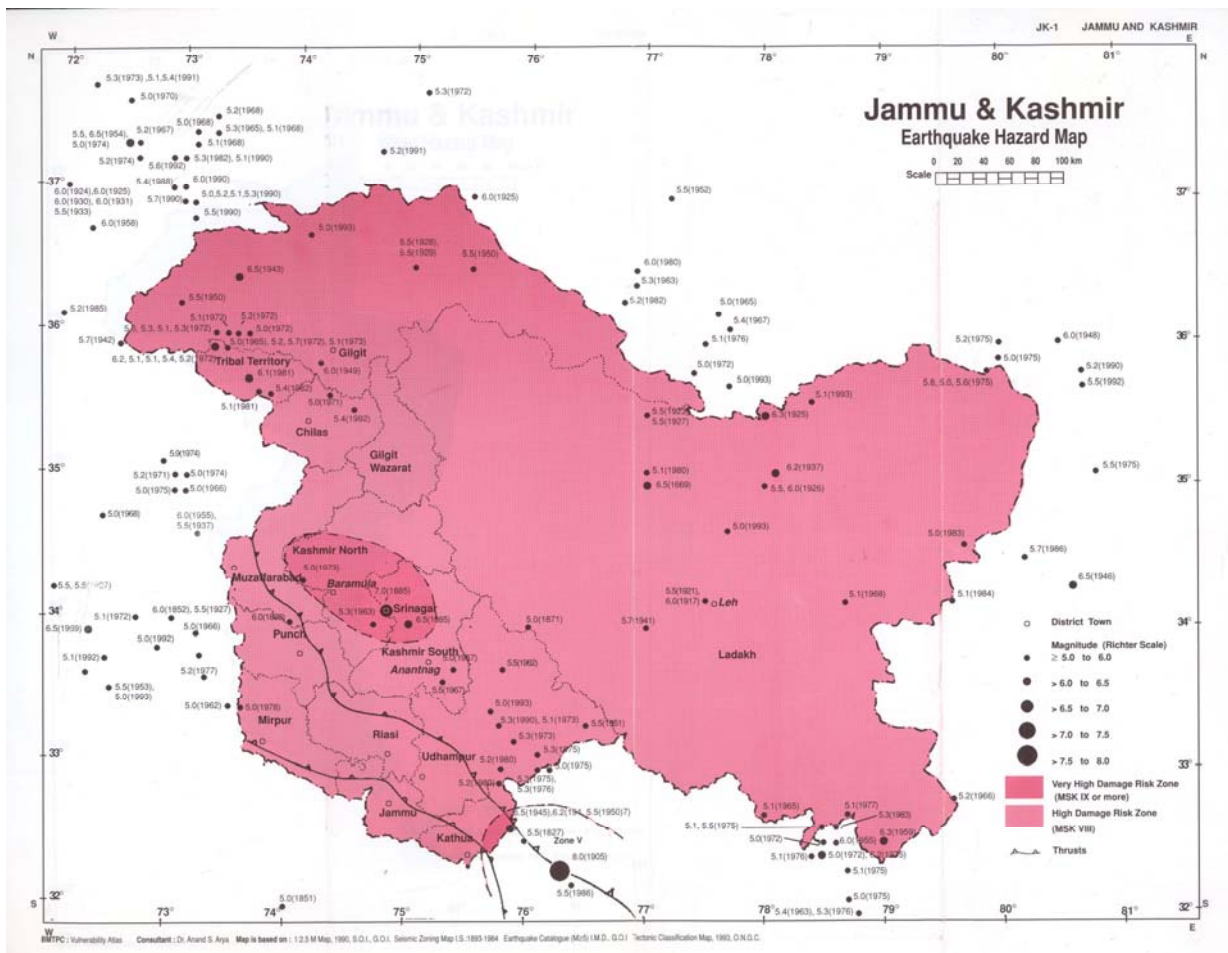

4. OPTIONS FOR WALL TYPES

The following wall types are normally used in stone-building construction.

Fig. 2.1 Seismic Zoning Map of Jammu & Kashmir

Type Of Wall	Relative Seismic Safety
(i) Dressed (Ashlar) stone masonry in cement mortar.	First (highest)
(ii) Coursed rubble stone masonry in cement mortar	Second
(iii) Random rubble stone masonry in cement mortar	Third
(iv) Dressed stone (Ashlar) masonry in mud mortar	Fourth
(v) Courses rubble stone masonry in mud mortar.	Fifth
(vi) Random rubble stone masonry in mud mortar.	Sixth (lowest)

From earthquake safety point of view, the above walls may be graded as shown against each. Unfortunately, their costs also vary more or less similarly except dressed stone masonry in mud may come second in place. In place of cement – sand mortar, appropriate mix of cement – lime – sand mortar may also be used if found economical and feasible.

Note: Dressed (Ashlar) stone masonry walls behave similar to other rectangular building units, such as brick, and concrete blocks and dealt fully in IS:4326 – 1993, the main safety features of which are included in these guidelines.

5. OPTIONS FOR ROOF AND FLOOR TYPES

The main type of roof and floors adopted in houses using stone masonry in Jammu & Kashmir are:

- 1) Wood logs supporting wooden planks.
- 2) Sawn wood rafters or trusses with sawn wood purlins covered with CGI sheets.

There is a tradition of using sloping roofs with light covering of corrugated galvanized sheet. The roof should have adequate slope to deal with snow & rain.

6. REQUIRED EARTHQUAKE SAFETY PROVISIONS

For the Seismic Zones V, & IV (MSK Intensity IX or higher and Int. VIII respectively) the following safety provisions are specified.

6.1 Building Categorisation (as per IS: 4326-1993 read with IS: 1893 - 2002)

In accordance with the value of the design seismic coefficient, the Building Category may be taken as follows for selecting earthquake resistance features:

Table 6.1 Building Categories

	Zone IV	Zone V
Housing	D	E
Community Buildings e.g. Schools, hospitals and congregation halls	E	E

6.2 Measures for Achieving Seismic Safety

6.2.1 For **all** Building Categories

In all seismic zones, the following measures should be adopted as per IS-4326 for masonry walls of all types.

- (i) Control on length, height and the thickness of walls in a room.
- (ii) Control on size and location of openings.
- (iii) Control on material strength and quality of construction.

6.2.2 Additional Measures for all building categories **D** to **E**

- (iv) Seismic band at plinth level (may be omitted if founded on rock or hard soil)
- (v) Seismic band at door-window lintel level in all cases.

Where flat roof is adopted:

- (vi) Seismic band at ceiling level of floors or roofs consisting of joisted roofs or jointed prefab elements.
- (vii) Stiffening of prefab elements in roofs/floor where used (using peripheral seismic band and RC screed integrated together).

where sloping/pitched roof is used:

- (viii) Seismic band at eave level of sloping roofs.
- (ix) Seismic band at top of gable wall and ridge wall top (where such walls used).
- (x) Bracing in roof structure of trussed as well as raftered roofs.
- (xi) Vertical Steel bar at each corner and T junction of walls.

6.2.3 Additional measures for all buildings of Category E.

- (xii) Seismic band or dowels at corners and T-junctions at window sill level.
- (xiii) Vertical steel reinforcing bars at jambs of doors and large windows.

Note: *The vertical reinforcement at jambs of small windows and ventilators (say 600 mm x 600 mm or less) may be omitted.*

7.0 SITING AND FOUNDATIONS:

The land slide prone areas as determined by the geologist should be avoided for construction or reconstruction of buildings.

7.1 New Foundations

7.1.1 Rocky Ground

Weathered, jointed and fissured rock may be levelled by chiseling, in steps of about 150 mm and stepped strip footing built on it, with the foundation width of 600 mm for two storeyed houses. Boulder site may be leveled by removing small boulders but leaving large boulders in place. If the rock is massive, the surface should be roughened by chiseling and stepped-strip footing built on it. In all cases, the base concrete of sufficient thickness (with a minimum of 100 mm) should be used for leveling before starting the masonry or concrete with plums.

7.1.2 Soil Site

Use stepped-strip foundation with minimum depth of 750 mm below ground level and width of 700 mm (upto 2 storeyed houses), Fig.7.1 For each additional storey, increase width by 300 mm. The footing masonry should be brought in steps upto the plinth level or concrete with plums may be used.

7.2 Use of Existing Old Foundation

Houses of pre-damage dimensions and heights could be built on existing foundation constructed in stone laid in compacted sand or mud mortar. The existing foundation may be excavated to about 230 mm below ground level where base concrete 150 mm thick in 1:4:8 mix is to be cast on the existing lower part of the footing (Fig.7.2).

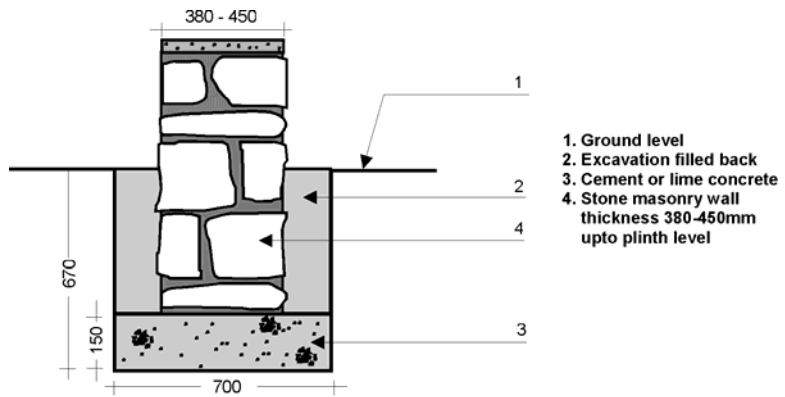

Fig. 7.1 strip foundation on soil sites

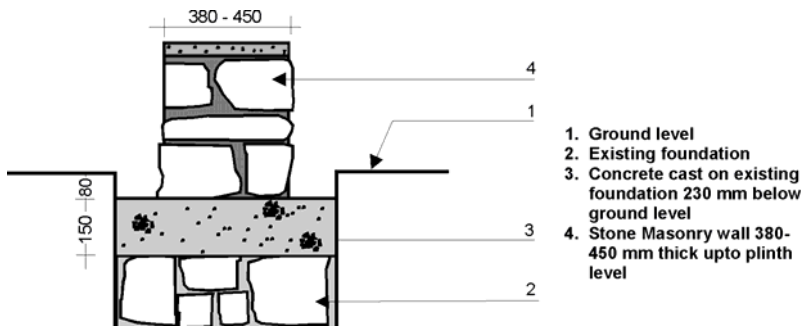

Fig. 7.2 Strip Footing on Existing Foundation.

8.0 TREATMENT AT PLINTH LEVEL

This will depend on site-soil condition as follows:

a. Rocky Ground

The seismic band at plinth is not required. Use damp-proof course (D.P.C.) as usual on the strip foundation. It may be cement-sand mortar of 1:3 mix 25mm thick or 1:2:3 micro concrete 38mm thick, with damp proofing compound mixed in each case [Fig.8.1(a)].

b. Boulder or Soil Site

In each case, use RC seismic band of 75 to 100mm thickness [Fig: 8.1(b)] for detail of the band).

Fig 8.1 DPC Alternatives

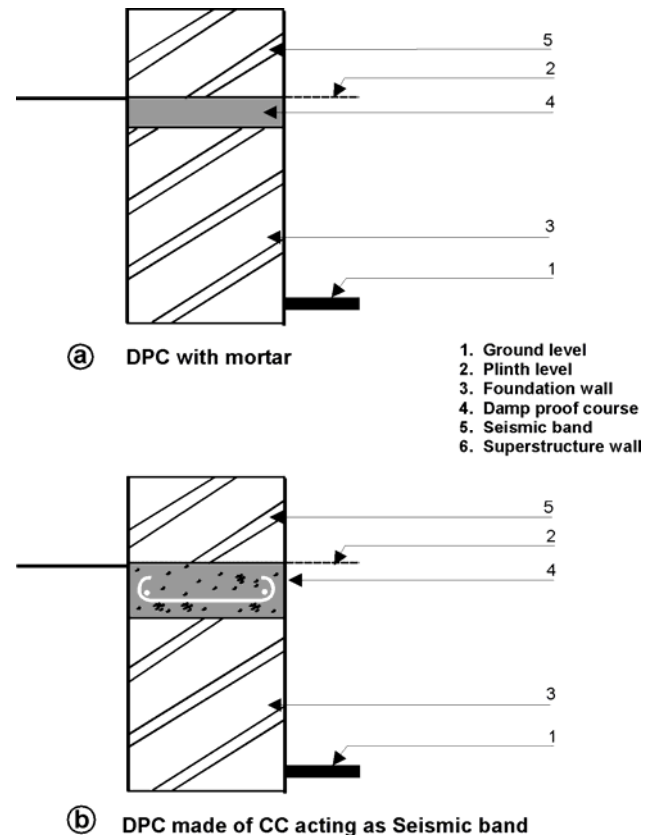

9. STONE MASONRY WALLS IN MUD MORTAR

Stone masonry walls built using mud mortar and other details as given in the following paras, could be used for *housing only*, for reasons of affordability or non-availability of cement supply. *Stone masonry in mud should not be used for community buildings such as schools, hospitals, mosques, etc.*

Note:-Round boulders should not be used for the construction of walls.

9.1 Construction Control

- (i) The mortar should be clay mud of good quality.
- (ii) The wall thickness 't' should preferably be kept 450mm, but not to be larger than 500mm. In any case, the stones of the inner and outer walls should be interlocked with each other as far as possible.
- (iii) The masonry should preferably be brought to courses at not more than 600 mm lift so as to achieve 'coursed rubble masonry'.
- (iv) 'Through' stones or 'bonding elements' of full length equal to wall thickness should be used in every 600 mm lift at not more than 1.2m apart horizontally (Fig.9.1).
- (v) In place of 'through' stones, 'bonding elements' of concrete bars of 50mm x 50mm section with an 8mm dia rod placed centrally or solid concrete blocks of 150 x 150 x length equal to wall thickness may be used. (Fig. 9.1). Alternatively, seasoned wooden battens of 50 mm x 50 mm size may be used as bonding element.
- (vi) Long stones of 600 mm length or solid concrete blocks of 150 x 150 x 600 mm size should be used at wall corners and T-junctions every 600 mm height to connect the perpendicular walls effectively (Fig.9.1). Alternatively, or seasoned wooden batten of 60 mm x 60 mm size may be used.

9.2 Control on Wall Length and Building Height

Height of the coursed rubble masonry walls in mud mortar should be restricted, with storey height to be kept 2.7m maximum, and span of walls between cross walls to be limited to 5.0 m as follows:

In Zone IV : preferably upto two storeys, in any case of category D or E

In Zone V: preferably one storey

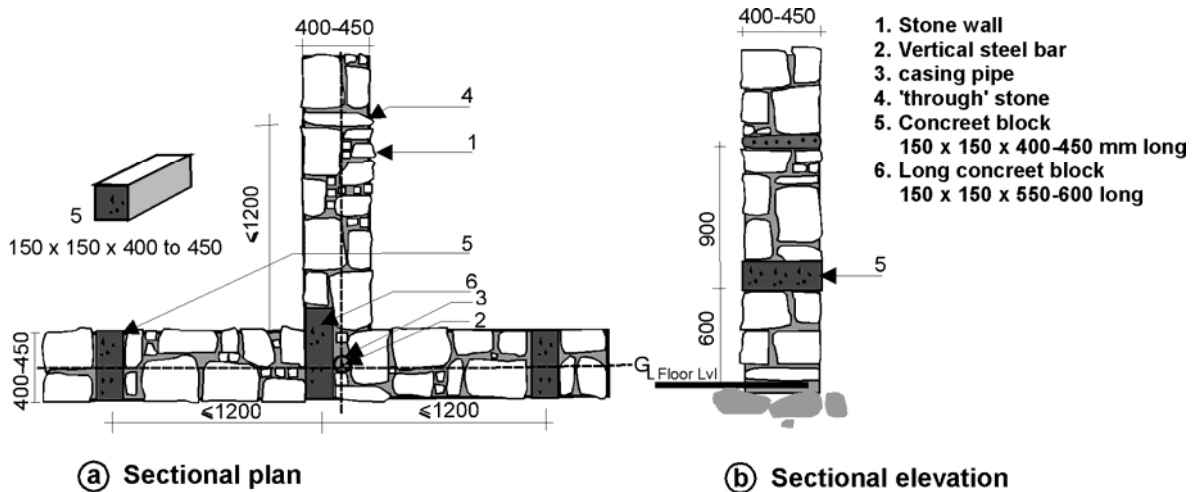

Fig. 9.1 'Through' stone or bond elements in stone wall built in mud mortar

If walls longer than 5m are needed, pilasters or buttresses may be used at intermediate points not farther apart than 3.5m. The size of the pilaster or buttress be kept of uniform thickness with top width equal to the thickness of main wall 't' and the base width equal to t or one sixth of wall height. See Fig. 9.2.

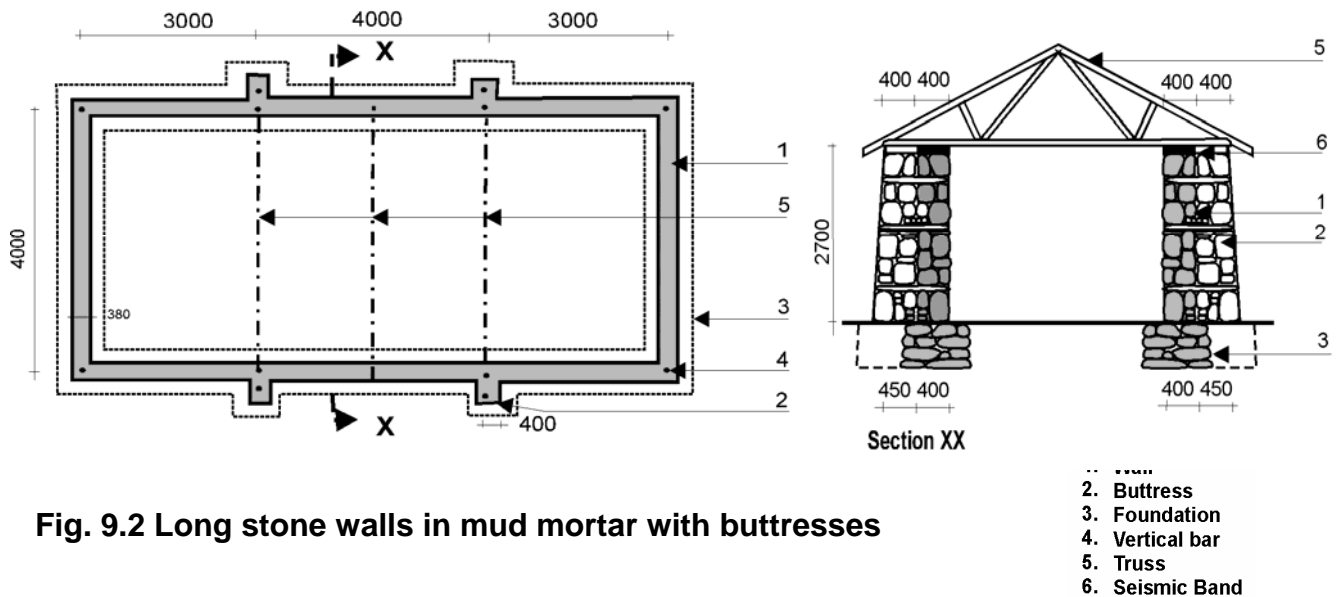

Fig. 9.2 Long stone walls in mud mortar with buttresses

9.3 Control of Openings in Bearing Walls

For coursed rubble stone masonry built in mud mortar, the door and window opening may be located in the walls as follows (Fig. 9.3).

Total length of openings in a wall = 0.33 of wall length in Category D and E

Distance of opening from inside corner: $b_5 \geq 600$ mm in Cat. D & E

Pier width between consecutive openings ≥ 600 mm

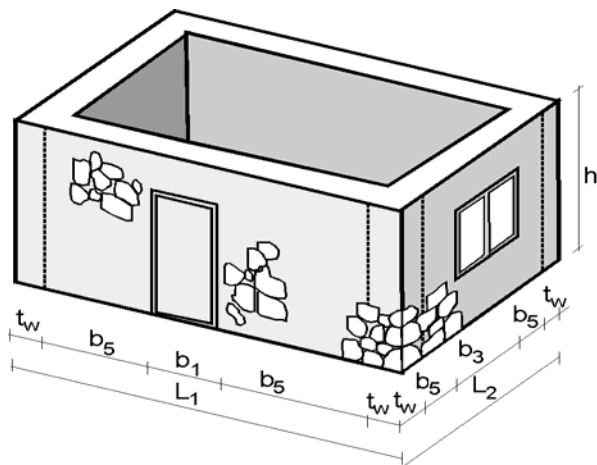

$$\begin{aligned}
 L_1 &\leq 5.0 \text{ m} \\
 h &\leq 2.7 \text{ m} \\
 b_1 &\leq 0.33 L_1 \\
 b_3 &\leq 0.33 L_2
 \end{aligned}$$

Fig. 9.3 Control on length, height and openings in stone walls built in mud mortar.

9.4 Seismic Bands

9.4.1 Definitions

Plinth Band

Plinth band is a band provided at plinth level of walls on top of the foundation wall. This is to be provided where strip footings of masonry (other than reinforced concrete or reinforced masonry) are used and the soil is either soft or uneven in its properties as frequently happens in hill tracts.

Lintel Band

It is a band provided at door/window lintel level on all load bearing internal, external, longitudinal and cross walls.

Ceiling Band

It is a band provided immediately below the roof or floors.

Gable Band

It is a band provided at the top of gable masonry below the purlins.

Eave band

It is a band provided on top of walls just below the sloping roof of rafters or trusses to which they will be securely fixed through nails and iron straps.

9.4.2 Overall Seismic Arrangement

The overall arrangement of seismic reinforcing of stone masonry buildings constructed in mud mortar is shown in Fig.9.4 for buildings with flat roof and in Fig.9.5 for building with sloping roof consisting of horizontal seismic bands and vertical wooden posts. The seismic bands at various critical sections shall be as follows:

- (i) Seismic bands at plinth, and lintel, ceiling or eaves level in buildings will be provided in all internal and external walls continuously without break and in

each storey. Requirement of wooden elements are given in fig. and the details of bands are shown there.

- (ii) In case of sloping roofs, triangular gable wall portions may be avoided and this area should be covered by A.C. & C.G.I sheets.

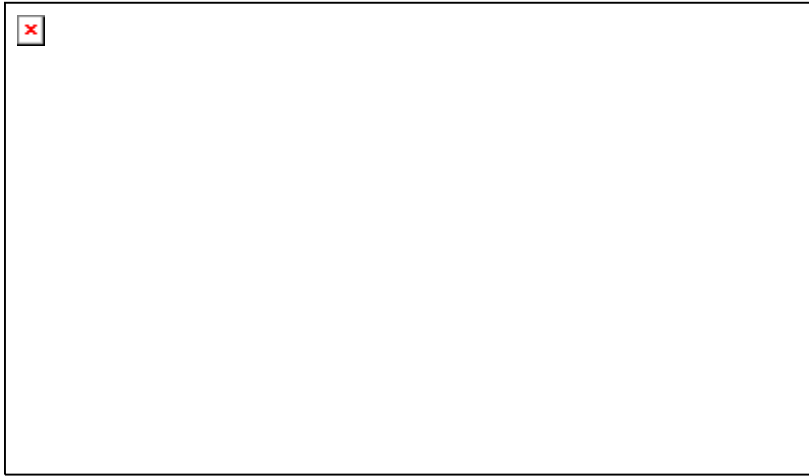

1. Lintel band
2. Ceiling/floor band
3. Vertical member
4. Door
5. Window
6. Plinth band
7. Dowels at wall corners

Fig. 9.4 :- Overall arrangement of earthquake resistant elements in single storeyed house having flat roof (roof not shown)

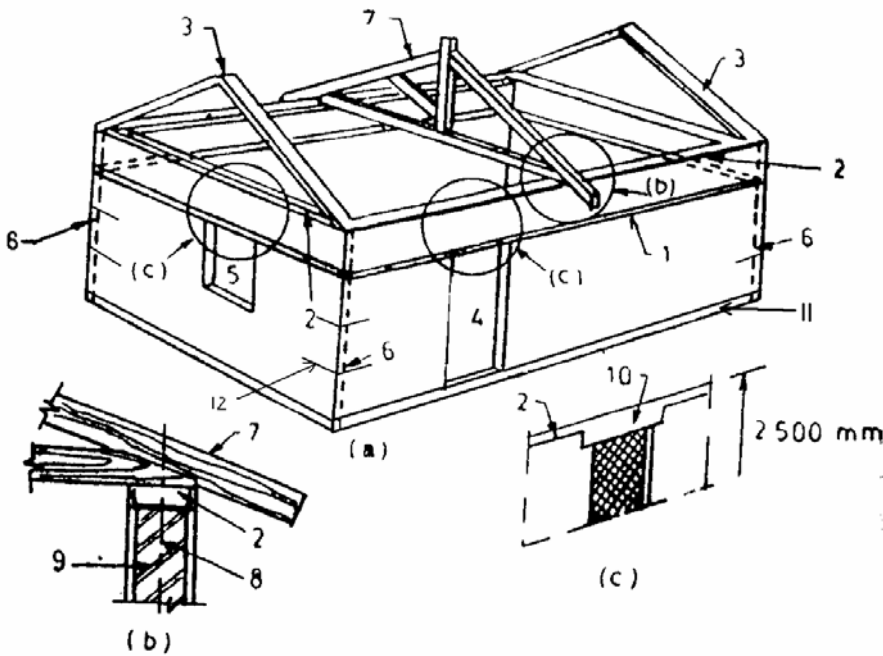

1. Lintel Band
2. Eaves level (roof) band
3. Gable band
4. Door
5. Window
6. Vertical member
7. Rafter
8. Holding down bolt
9. Brick/stone wall
10. Door lintel integrated with roof band
11. Plinth Band
12. Dowel at wall corners in Seismic Zone V

Fig. 9.5

(a) Perspective

(b) Details of truss connection with wall

(c) Detail of integrating door lintel with roof band

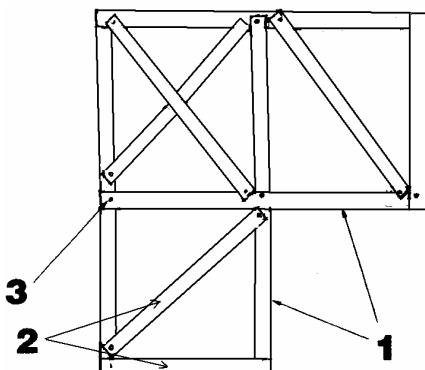

1. 30 X 50 mm wooden member
2. 30 X 50 mm wooden member
3. Long & broad-headed through nails bent at the other end

Fig.9.6:- Dowels at wall corners in building category E

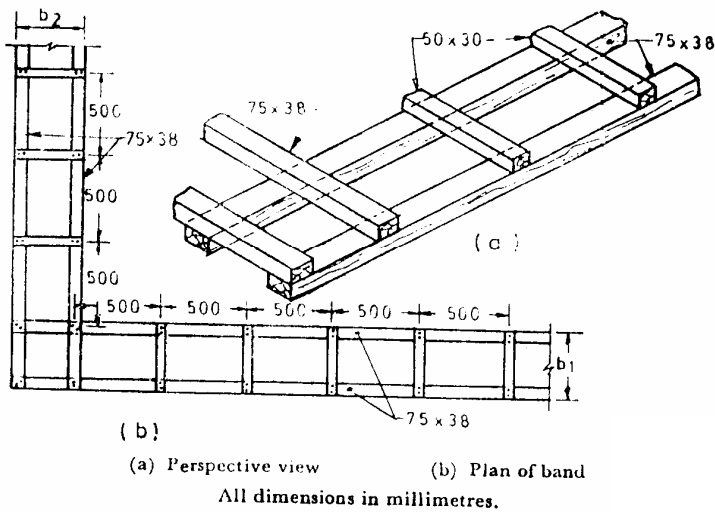

Fig.9.7: Wooden band for low strength masonry buildings

9.5 Vertical Reinforcement at Corners

For vertical reinforcement, wooden planks of size 50 X 30 mm & 80 X 30 mm joined together by nails forming a L section is to be used and this vertical member is to be nailed to the wooden seismic bands at plinth, sill, lintel and eaves level (see fig. 9.9). The vertical reinforcement is to be placed at all the corners of the rooms.

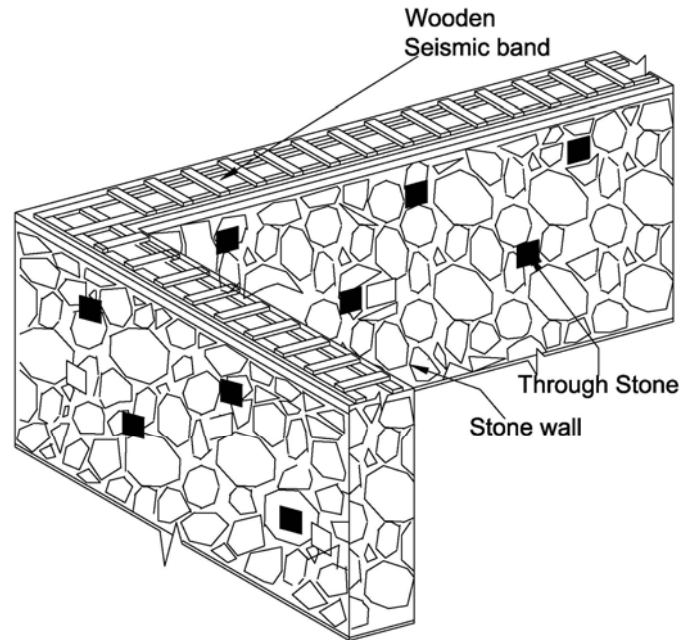

Fig.9.8: Isometric view of wooden band on stone masonry building

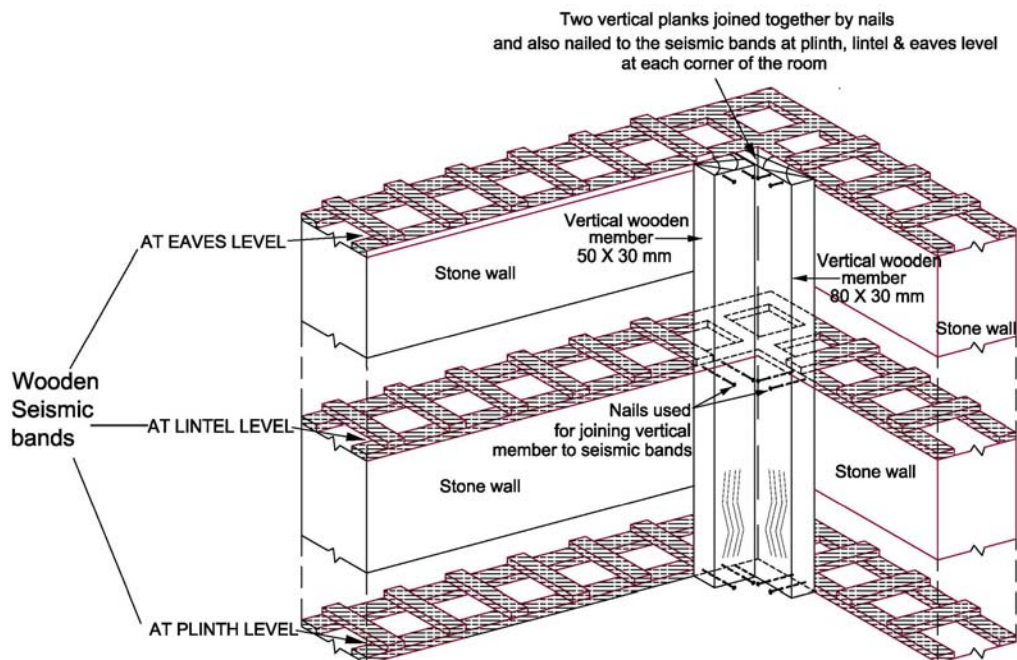

Fig. 9.9:- Fixing of vertical planks with the wooden seismic bands

9.6 Water Proofing

9.6.1 For protection of external walls against damage by water

- (i) Take out roof projection beyond the walls by about 300mm, and
- (ii) Use cement-sand mortar pointing on external face of walls; *OR*
Use waterproof mud plaster on external face of walls, which may be done as per 9.6.2.

9.6.2 Water Proof Mud Plaster

- (i) Prepare cut-back by mixing bitumen 80/100 grade and kerosene oil in the ratio 5:1. For 1.8 kg cut-back, 1.5 kg bitumen is melted and is poured in a container having 300-millilitre kerosene oil, with constant stirring till complete mixing.
- (ii) Mix this mixture with 0.03 cu.m (30 litres) of mud mortar to make it both, water repellent and fire resistant.
- (iii) The waterproof plaster is to be applied in 20 to 25mm thickness and allowed to dry. It may then be coated twice with a wet mixture of cow-dung and waterproof plaster in the ratio of 1:1 and allowed to dry again.

10. STONE MASONRY USING CEMENT MORTAR

Stone masonry using cement mortar and other details as set out in the following paras may be used for all building categories in the area.

10.1 Construction Control

10.1.1 *Mortar.* The mortar in superstructure masonry should be cement-sand (1:6 in category D and 1:4 in category E buildings).

In the foundation masonry upto plinth, the mix 1:6 may be kept in all cases or concrete with plums be used.

10.1.2 *Composite Mortar.* In place of cement–sand 1:6 and 1:4 mortars, cement–lime–sand mortar may be used as 1:2:9 and 1:1:6 respectively.

10.1.3 *Wall Thickness.* The wall thickness should not be larger than 380 mm (not more than 400 mm in any case) and the stones on the inner and outer wythes should be interlocked with each other as far as possible.

10.1.4 *Coursed.* The masonry should preferably be brought to courses at not more than 600 mm lift.

10.1.5 *'Through' Stone* 'Through' stones of full length equal to wall thickness should be used in every 600 mm lift at not more than 1.2 m apart horizontally (Detail as per Fig.10.1)

In place of 'through' stones, 'bonding elements' of concrete bars of 50mm x 50mm section with an 8 mm dia rod placed centrally or solid concrete blocks of 150 x 150 x walls thickness, can also be used.

10.1.6 *Corner Stones.* Long stones of 500-600mm length should be used at wall corners and T-junctions of walls. Alternatively use of 150x150x(500 to 600) solid concrete blocks to connect the perpendicular walls effectively (Detail as per Fig.10.1).

10.2 Control on Wall Length and Building Height

10.2.1 Height

The height of the coursed-rubble masonry walls in cement mortar should be restricted as follows:

- (i) *For Category D:* Two storey plus attic.
- (ii) *For Categories E & E+:* Two storeys with flat roof or one storeys plus attic for pitched roof.

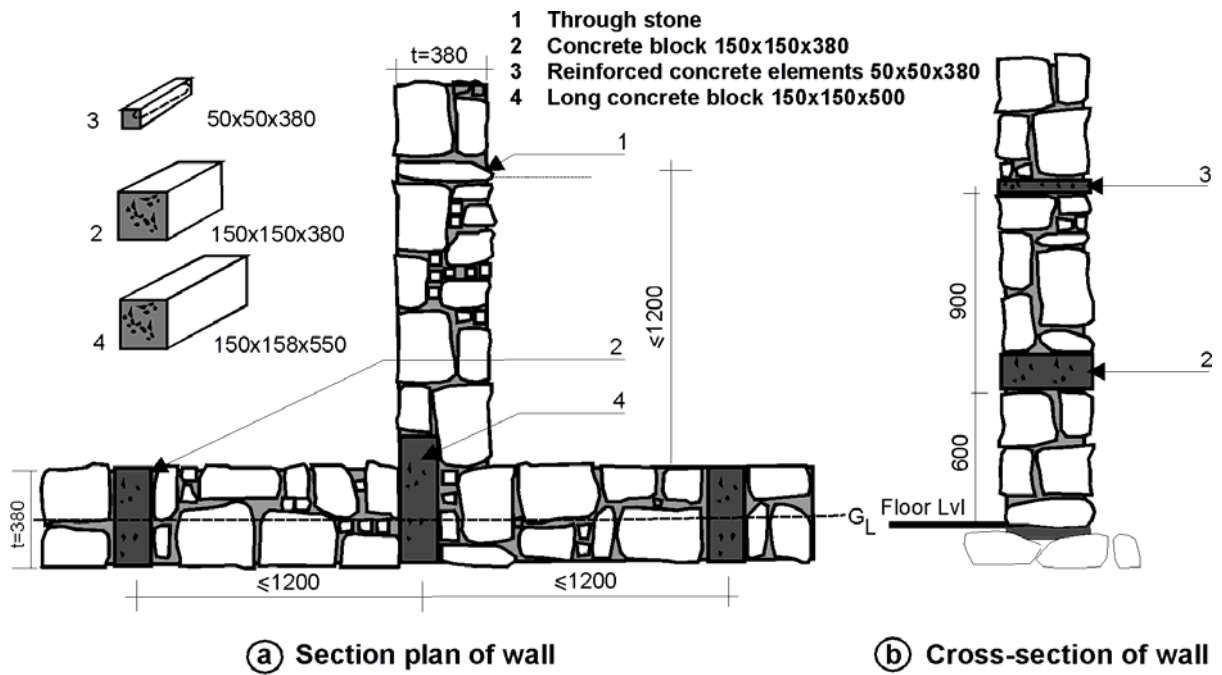
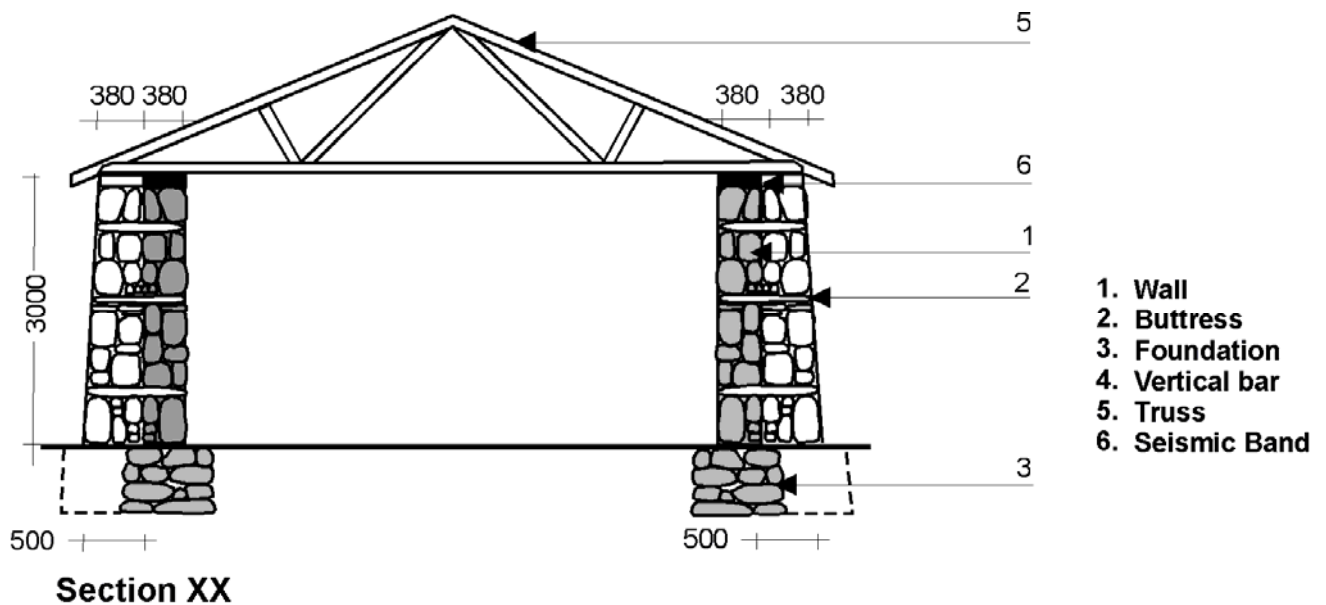

Fig. 10.1 'Through' stones and bond elements (Cement mortar)

The storey height to be kept 3.2m maximum, and span of walls between cross walls to be limited to 7.0m. If rooms longer than 7m are needed, buttresses may be used at intermediate points not farther apart than 5.0m. The size of the buttress be kept of uniform thickness with top width equal to the thickness of main wall and the base width equal to one sixth of wall height. (See Fig. 10.2 for arrangement of pilasters or buttresses).



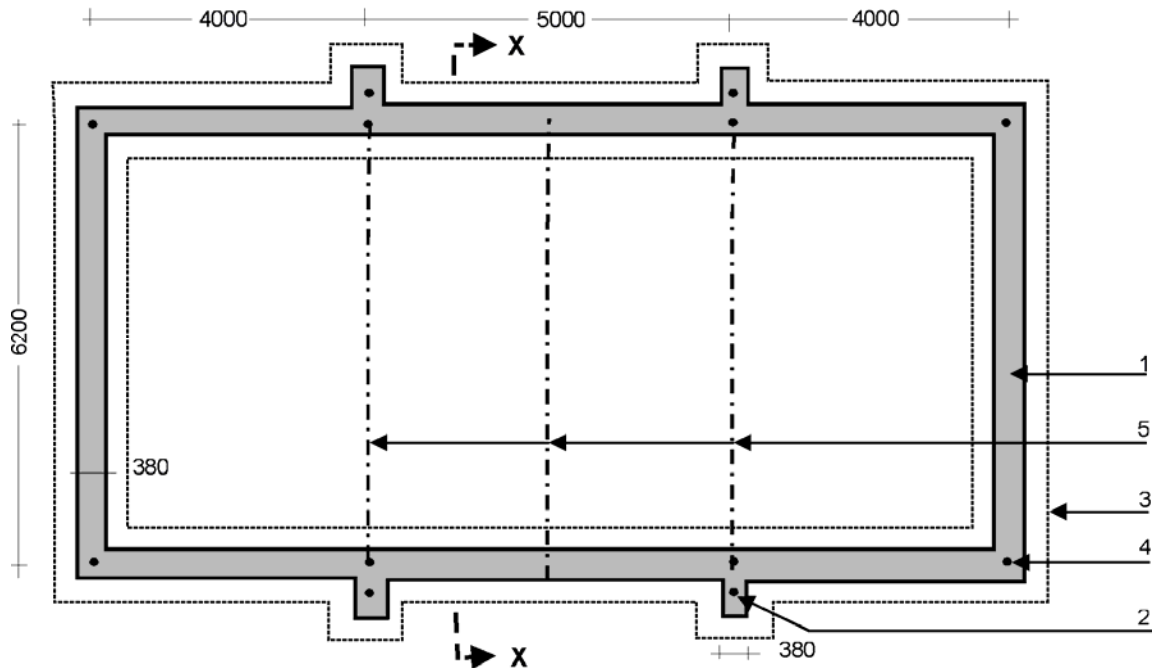
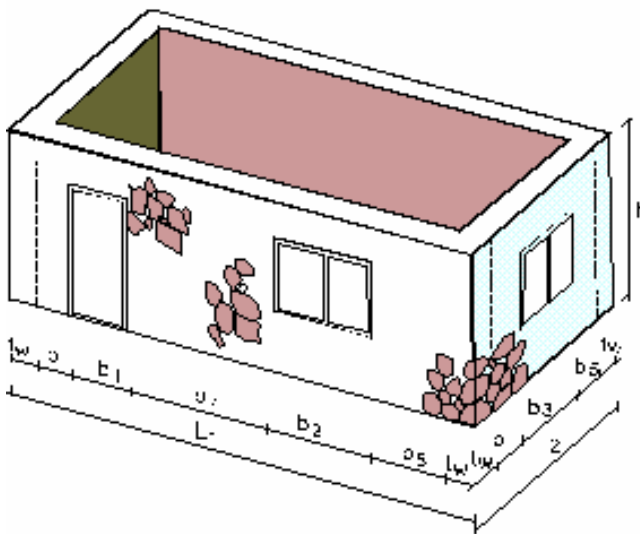

Fig.10.2:- Long walls with buttresses (cement mortar)

10.3 Control of Openings in Bearing Walls

For stone masonry built in cement mortar and brought to courses, the door and window openings should be controlled as follows: (Fig. 10.3).



$L1 \leq 7.0$ m
 $H \leq 3.23$ m
 $b1 + b2 \leq 0.5 L1$ in 1 storey building
 0.42 in 2 storey building

$b3 \leq 0.5 L2$ in 1 storey building
 0.42 in 2 storey building

Fig.10.3: – Control on length, height & openings of wall (cement mortar)

Ratio of total length of openings in a wall to length of the wall in a room should not exceed 0.5 in single storeyed and 0.42 in 2-storeyed.

Distance of opening from inside corner \geq 450mm
 Pier width between consecutive openings \geq 600mm

10.4 Seismic Bands

10.4.1 Overall Arrangement

The overall arrangement of seismic reinforcing of masonry buildings is shown in Fig. 9.4 for buildings with flat roof and in Fig. 10.5 for building with sloping roof consisting of horizontal seismic bands and vertical bars. The seismic bands at various critical sections shall be as follows:

- (i) Seismic bands at plinth, and lintel, ceiling or eaves level in buildings will be provided in all internal and external walls continuously without break in all storeys. Requirement of reinforcing bars in RC bands are given in Table 9.1 and the details of bands are shown in Fig. 10.6.
- (ii) In case of sloping roofs, triangular gable walls must be enclosed within eave level band and a band at the top of the gable wall. These bands must be made monolithic and continuous as shown in Fig. 10.7.

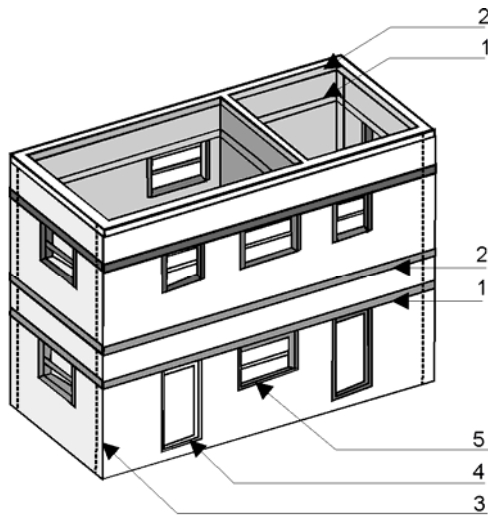

1. Lintel band
2. Roof/floord band
3. Vertical bar at corner
4. Door
5. Window

Fig. 10.4 Overall arrangement of earthquake resisting elements in double storeyed houses having flat roof (Roof not shown)

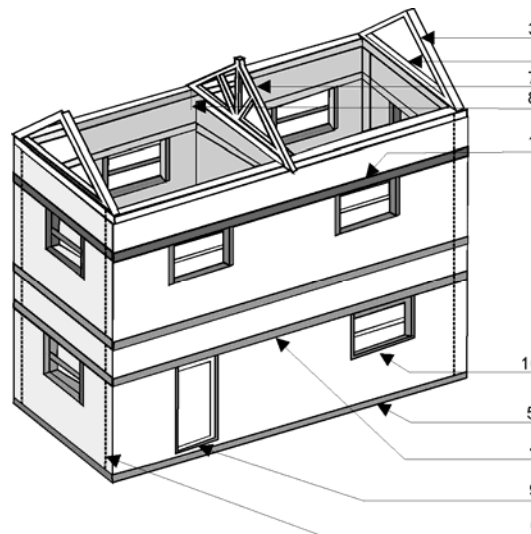

1. Lintel band
2. Eave level (Roof) band
3. Gable band
4. Floor band
5. Plinth band
6. Vertical bar
7. Rafter
8. Holding downbolt/Vertical bar
9. Door
10. Window

Fig. 10.5 Overall arrangement of reinforcing in masonry double storey building having pitched roof (Roof not shown)

**Table 10.1 : Longitudinal Bars* in RC Bands
(Stone Masonry in Cement Mortar)**

Length of wall in room (m)	Reinforcing Bars in Building Categories			
	Cat. D		Cat. E or E+	
	No	Dia (mm)	No	Dia (mm)
≤ 5	2	8	2	10
6	2	10	2	12
7	2	12	4	10

High Strength Deformed (Tor) bars

Fig.10.6:- Longitudinal Bars and links/stirrups in R.C. Bands

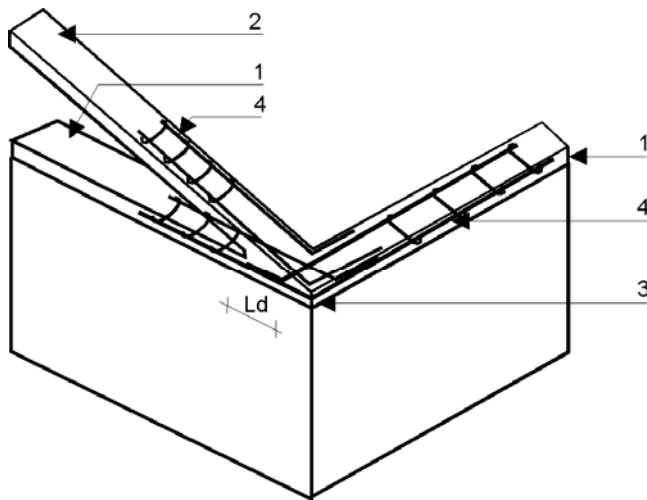
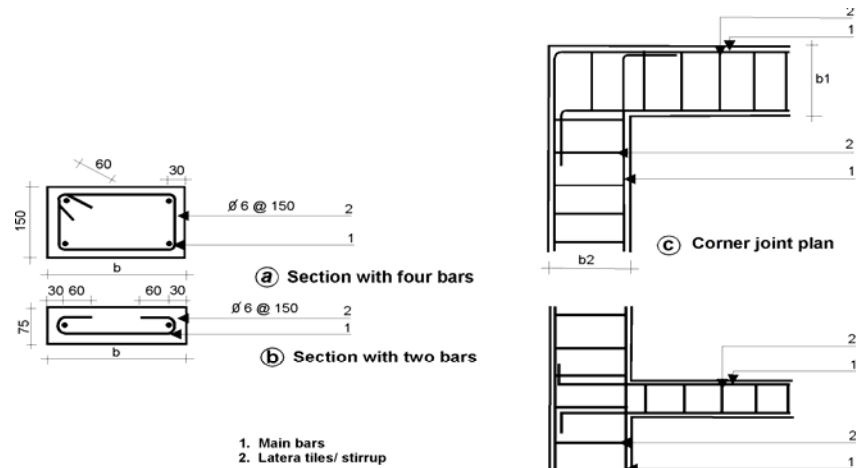

- 1. Eave band
- 2. Gable band
- 3. Joint of Eave and Gable bands
- 4. Main reinforcing bars
- Ld. Overlap length

Fig. 10.7:- Continuity of reinforcement in eave and gable bands.

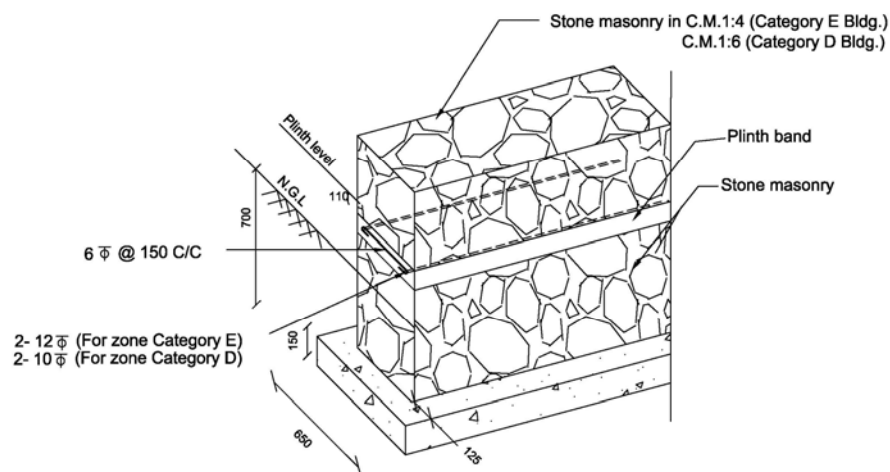

Fig.10.8:- Isometric view of plinth band in stone masonry wall

(iii) For achieving good bond with masonry, the bands should be cast directly on the masonry and its top surface should be made rough. In the case of plinth and lintel band, stones may be cast in the concrete to project out of the concrete by 50 to 75mm so as to be built into stone walls.

10.5 Vertical Reinforcing Bars in Walls

The vertical reinforcing of walls consists of a single high strength deformed (HSD) or 'TOR' bar (See Table 10.2 for required diameters) located at each critical point as stated in 6.2.3.

**Table –10.2: Vertical Bars at Corners of Room
(Stone Masonry in Cement Mortar)**

No. of Storeys	Storey	Diameter Of Single HSD (TOR) Bar at Corners of Room	
		Cat. D	Cat. E.
One	---	10	12
Two	Top	10	12
	Bottom	12	16

10.5.1 Installation of Vertical Bars

For installations of vertical bars in stone masonry, use of PVC casing pipe of 100mm external dia, 600-750 mm long is recommended around which masonry be built to height 450-600mm (see Fig. 10.9 & 10.10) and the pipe made loose by gently rotating. As the masonry hardens, the pipe is raised and the cavity filled with M20 concrete (nominal mix of 1:1.5:3) and fully compacted by rodding using 12mm dia and 600mm long bar.

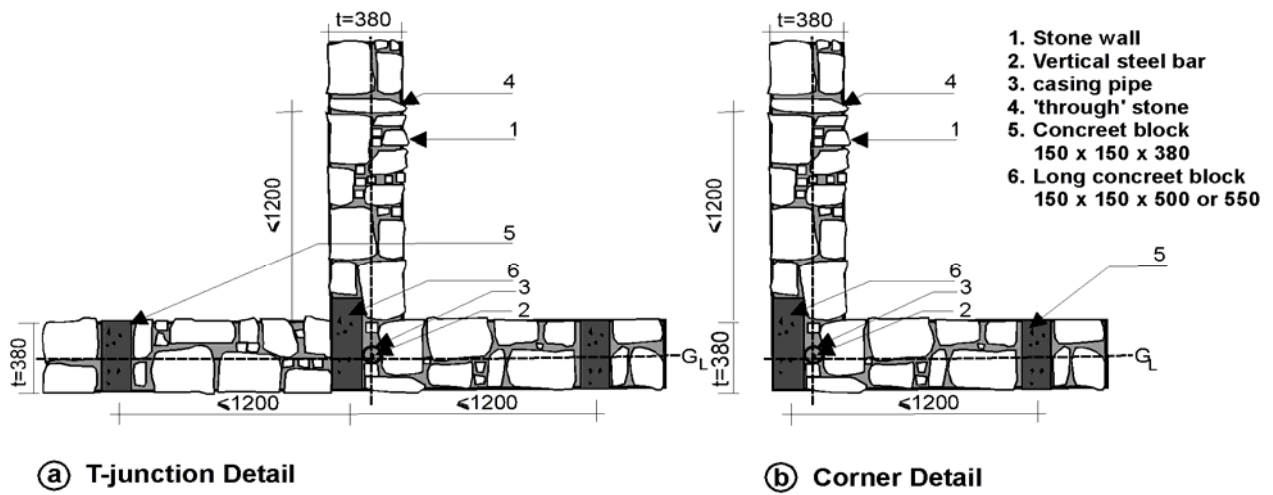

t = 380 for cement mortar, 450 for mud mortar

Fig.10.9:- Installing vertical steel bars in stone masonry walls

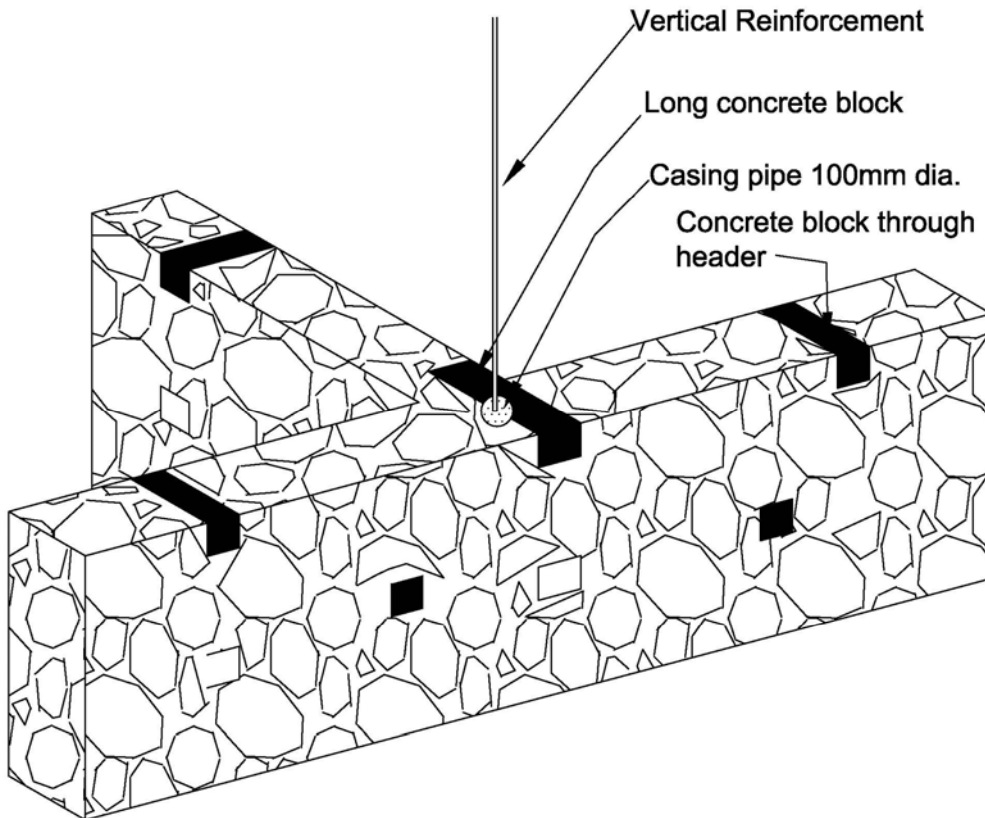

Fig.10.10:- Isometric view of the vertical reinforcement at the T junction

10.5.2 Keeping the Bar Vertical

Before casting the foundation, the vertical bars must be kept in correct in position horizontally and vertically. For this purpose tripods may be erected using bamboos or spare reinforcing bars (See Fig. 10.11).

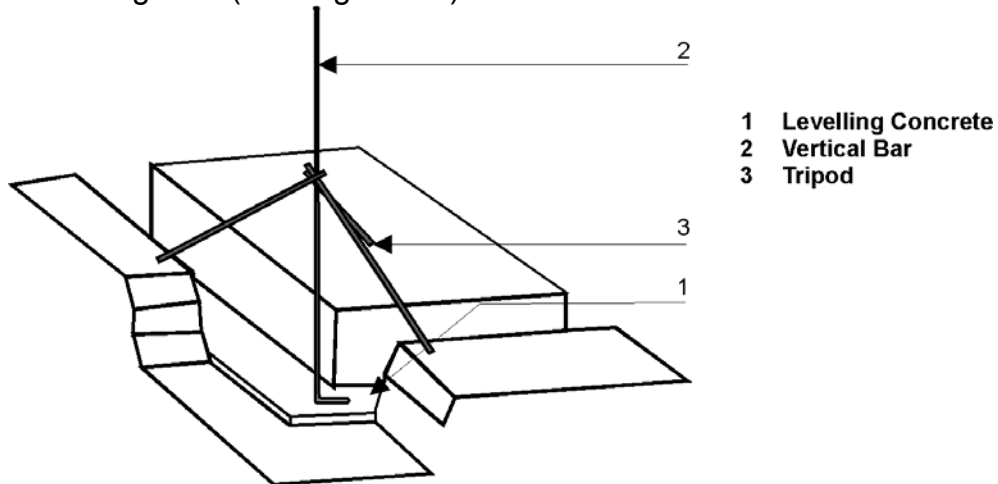

Fig. 10.11:- Keeping the bar vertical

10.6 Vertical Reinforcement at Jambs of Openings

The vertical bars are to be provided at the jambs of large openings in all category E buildings. However, if the conditions of section 9.3 are not met, the openings should be boxed in R.C. with minimum 75 mm thickness and two H.S. bars of 10 mm dia. In category D & E buildings (see fig. 10.12).

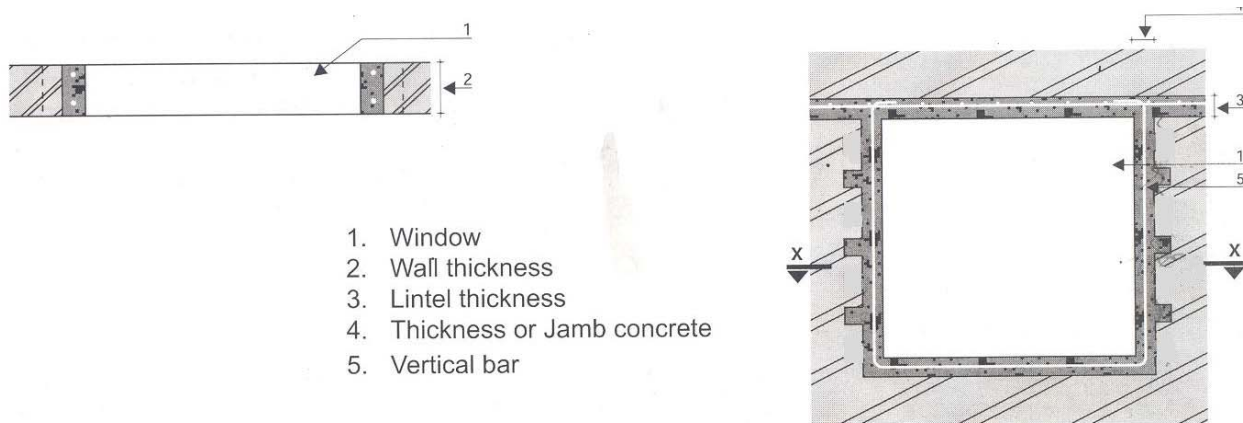

Fig. 10.12:- Strengthening masonry around window opening

11. MASONRY WALLS WITH BRICK

All New Buildings should be made earthquake resistant in the first instant so that we do not add to the stock of existing unsafe buildings. Since most of the buildings are constructed using brickwork or, solid hollow concrete blocks with flat roofs, very simple illustrated guidance is provided for incorporating the earthquake resistant features suitable for seismic zone IV & V.

11.1 Essential Elements for Earthquake Safety¹:

The essential elements required to make a building earthquake safe are as given in **fig.11.1**. Some additional requirements are detailed in the following paragraphs.

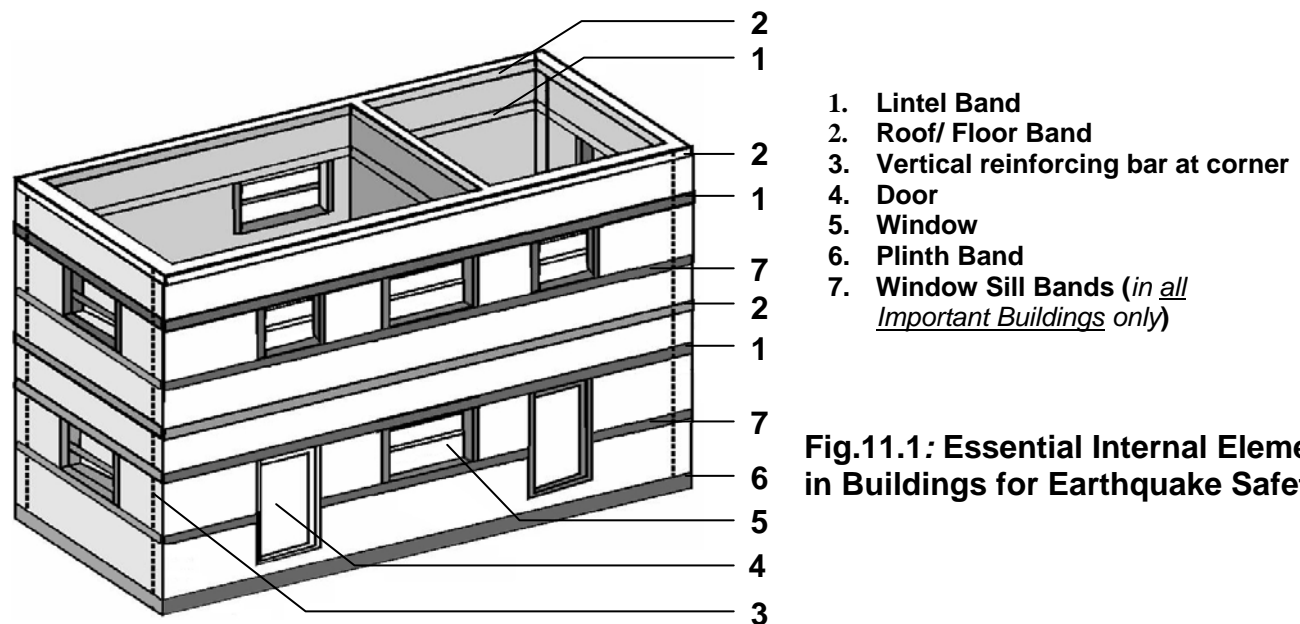

Fig.11.1: Essential Internal Elements in Buildings for Earthquake Safety

11.2 Good Cement Mortar:

The cement mortar should be used in the ratio of 1 part of cement with 6 parts of sand (1 sack of cement mixed with 6 equal sacks of sand) for category D and 1:4 mix for category E building.

11.3 Opening in Bearing Walls

As doors & window openings in walls reduce their lateral load resistance and hence, should preferably be small and more centrally located. The guidelines on the size and position of opening are given in Table 11.1 & Fig.11.2.

¹ The details given here are extracted from **IS: 4326-1993 Code of Practice** as applicable to buildings with Brick/Concrete block walls and R.C. flat slab roofs. Details not given here may be seen in the Code.

Table 11.1:- Size & position of openings in bearing walls

S. No.	Position of Opening	Details of Opening for Building Category	
		D	E
1	Distance b_5 from inside corner of outside wall, Min.	450 mm	450 mm
2	$(b_1 + b_2 + \dots)/l$, max. one storey two storey	0.50 0.42	0.5 0.42
3	Pier width between 2 consecutive openings . b_4 , min.	560 mm	560 mm
4	Vertical distance between 2 openings one above the other h_3 , Min.	600 mm	600 mm

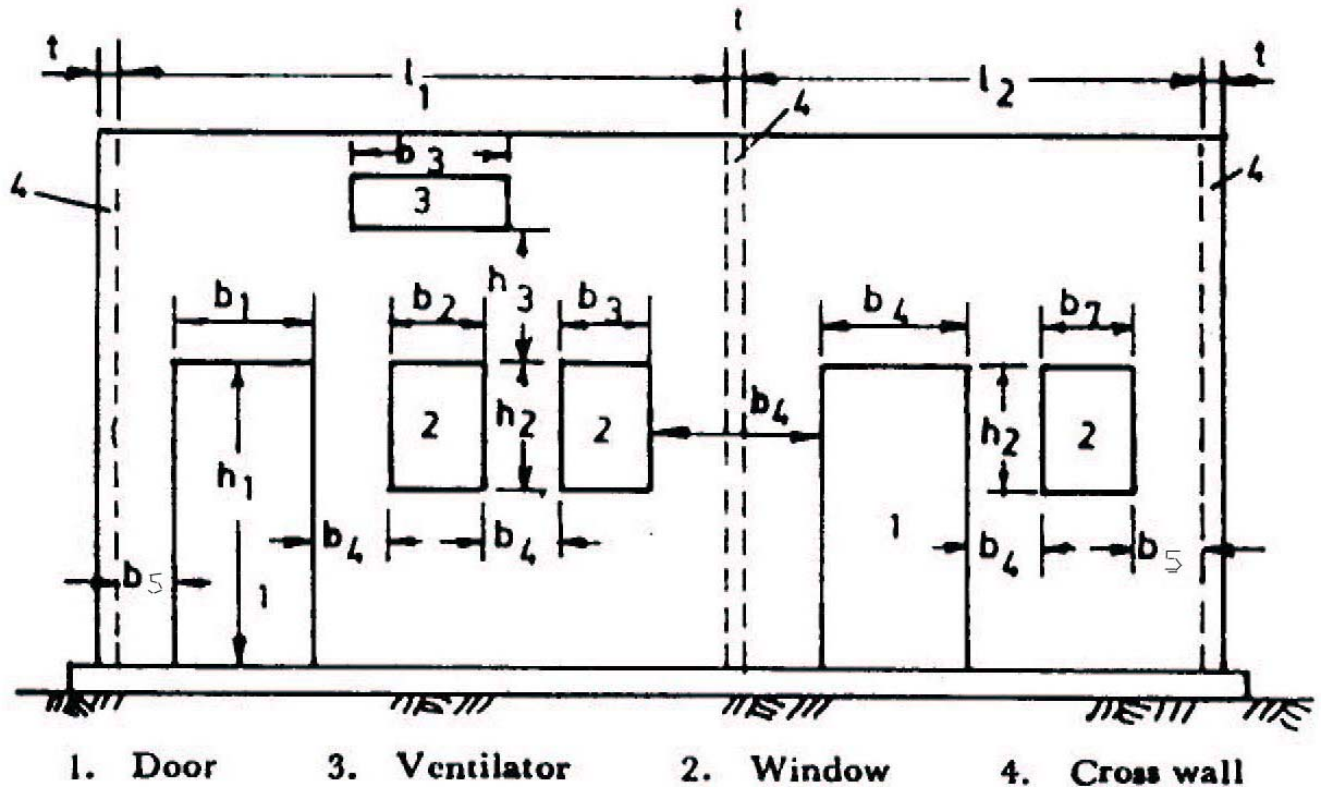

Fig. 11.2:- Dimension of Openings and Pier for Recommendations in Table 11.1

11.4 Seismic Bands:

A seismic band consists of reinforced concrete flat runner through **all external and internal masonry walls** at the following levels in the building.

- a) at the plinth level of the building

- b) at the levels of lintels of doors and windows
- c) at the ceiling level of roofs consisting of wooden joists or, prefabricated reinforced concrete beams or, planks. (Such band will not be necessary if the roof consists of Reinforced Concrete or, Reinforced Brick slabs cast on the walls covering a minimum of 2/3 of the thickness of the wall.)

The dimensions of the band and the reinforcement inside depend upon the length of the walls between the perpendicular cross walls. The **table -10.1** given earlier shows the dimensions to be adopted for the seismic bands and the internal reinforcement details to be provided. The reinforcement and bending details of seismic bands are same as given in the **fig.-10.6**. Reinforcing bars will be of Fe 415 type [TOR or, High Yield Strength Deformed, i.e. HYSD bars]

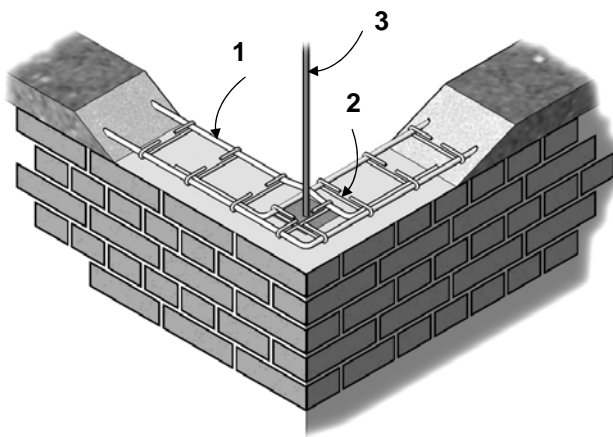
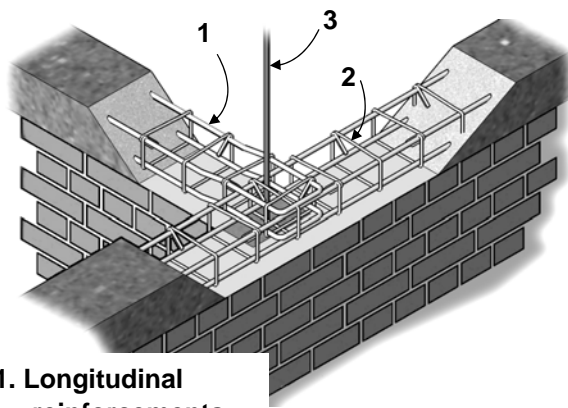

Fig.11.3: 3 Dimensional view of the L - type wall junction



- 1. Longitudinal reinforcements
 - 2 Lateral Ties
 - 3. Vertical reinforcement at corners
- b, b1, b2 Wall thickness

Fig.11.4: 3 Dimensional view of the T - type wall junction

11.5 Vertical reinforcement in the brick walls:

For earthquake safety of category E buildings reinforcing bars have to be embedded in brick masonry at the corners of all the rooms and the side of the door openings. Window openings larger than 60 cm in width will also need such reinforcing bars. The diameter of the bar depends upon the number of storeys in the building. The recommendations are same as given in **Table-10.2**.

Providing the vertical bars in the brickwork and concrete blocks requires special techniques shown in **fig.11.5 and 11.6**, which could be easily learnt by the supervising engineers and masons will need to be trained.

These vertical bars have to be started from the foundation concrete, will pass through all seismic bands where they will be tied to the band reinforcements using binding wire and embedded to the ceiling band/roof slab as the case may be using a 300 mm 90° bend. Sometimes the vertical bars will not be made in one full length. In that case the extension of the vertical reinforcement bars are required, an overlap of

minimum of **50 times the bar diameter** should be provided. The two overlapped reinforcement bars should be tied together by using the binding wires.

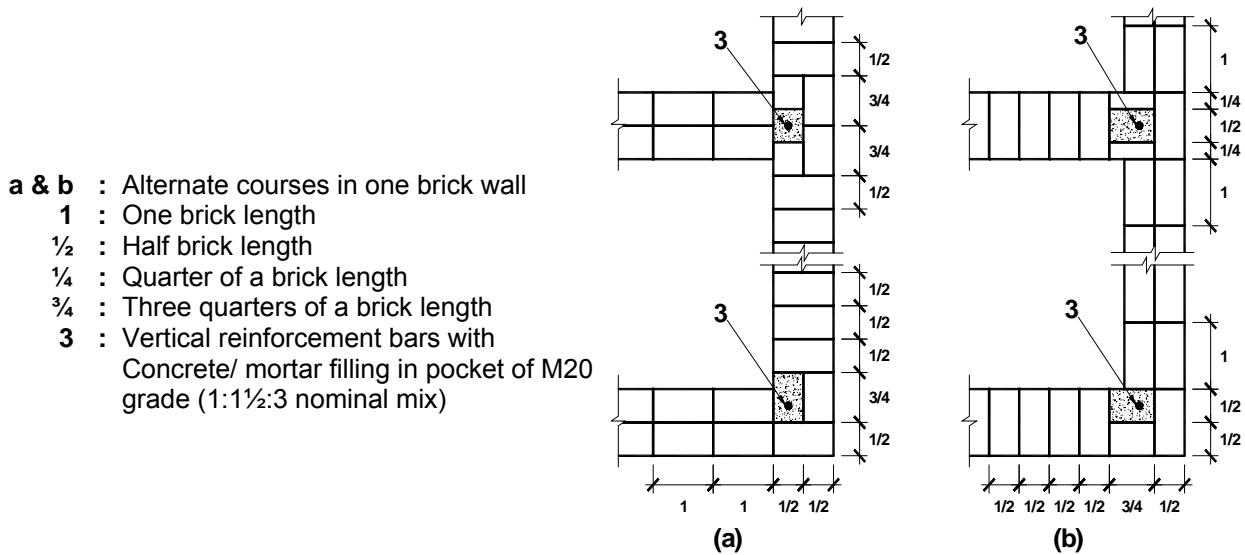

Fig.11.5: Typical Details of Providing Vertical Steel Bars in Brick Masonry

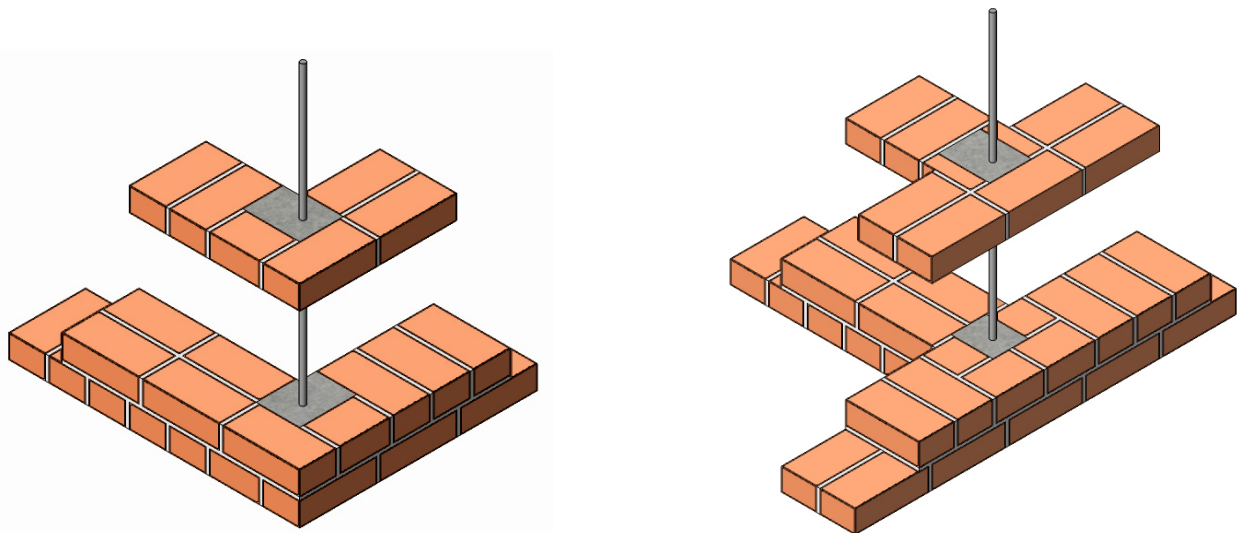

Fig.11.6: Recommended joint details with the vertical reinforcement at corner of brick masonry walls

MASONRY WALL WITH CONCRETE BLOCKS

12.1 Concrete Block Masonry

Two types of cement concrete blocks are commonly used:

- (i) Solid concrete blocks of nominal size 300 X 200 X 150 mm (actual size 290 X 190 X or 200 X 140 mm)
- (ii) Hollow concrete blocks of nominal size 300 X 200 X 150 mm

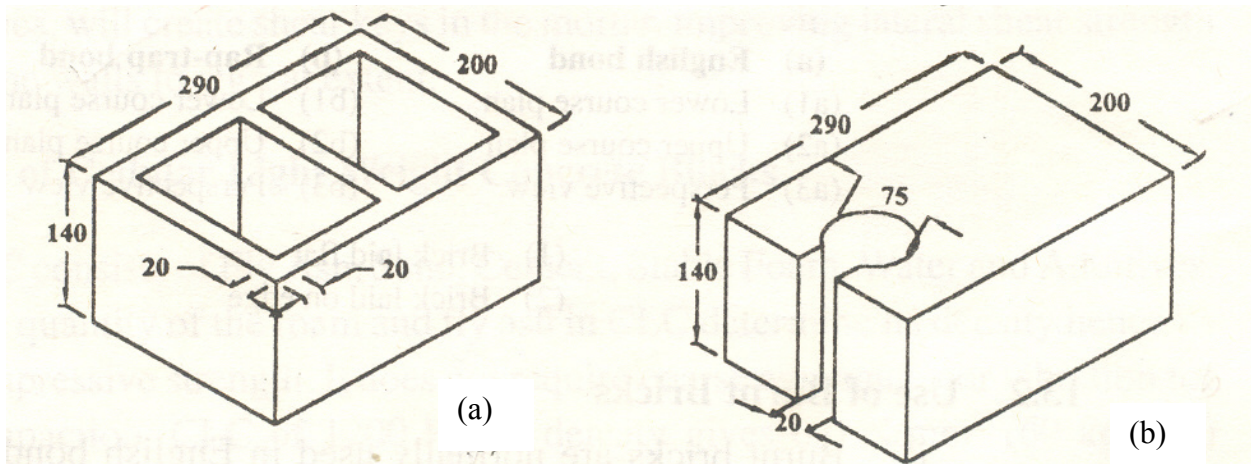

**Fig.12.1: (a) Hollow Concrete Block
(b) Solid Concrete Block**

12.2 Use of Solid Concrete Blocks

- (i) Using the concrete blocks of 300 X 200 X 150 mm nominal size, non-load bearing walls of 150 mm thickness and bearing walls of 200 mm thickness could be built. The bearing surfaces of the blocks should be made rough by the casting procedure to develop good bond with the mortar. Alternatively, a frog could be created similar to that in the bricks (say 150 X 100 X 6 mm deep so as to provide a shear key in the mortar joint).
- (ii) Since unlike the bricks, breaking the blocks is not convenient, special L/2 and L/3 blocks (140 mm and 90 mm) should be cast and used to break the continuity of vertical joints.
- (iii) Also, so as to fit the units without breaking, the size of doors, windows, built-in cupboard, open shelves, etc. and piers between them should be multiples of the modular dimensions of 100 mm.

12.3 Use of Hollow Concrete or Micro Concrete Blocks

Hollow blocks have larger breakage loss during transportation than the solid blocks. Hence a higher crushing strength on the solid portion of the hollow blocks is essential. To achieve this, the minimum crushing strength of the blocks on the solid area should be kept about 9.0 MPa and on the gross area as 5.0 MPa.

12.4 Use of Mortar

The minimum crushing strength of the masonry units on their gross area and the mortar mix should be as given before.

12.5 Control on Wall Height and Length of Rooms

Same as for brick work in concrete mortar.

12.6 Control on Door/Window Openings

When cement mortar as described are used in the construction of houses, the same conditions as for brick in cement mortar are to be used.

12.7 Seismic Bands

These will be the same as for stone masonry in cement mortar.

12.8 Vertical Reinforcing Bars in Walls

Same as for stone masonry in cement mortar.

12.8.1 Vertical Bars in Solid Concrete Block Walls

Since a cavity formation in solid block walls is not feasible, special concrete blocks with one hollow are cast and used at the bar-points. To avoid raising of the hollow blocks high for enclosing the bar in a hollow, slit is made in the wall of the hollow while casting the block. (see fig. 12.2)

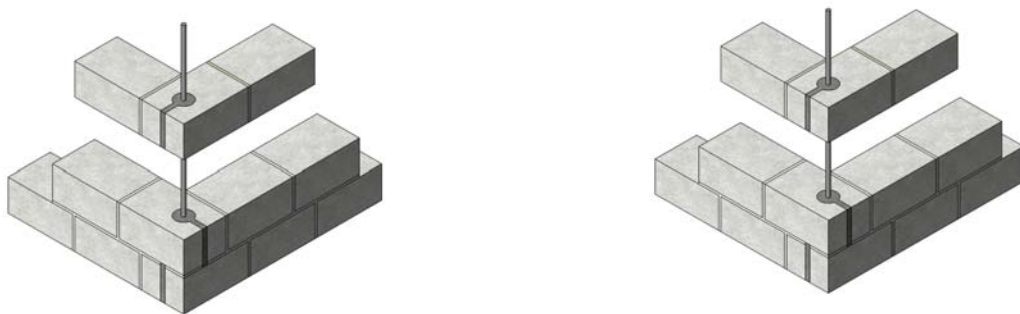

Fig.12.2:- Corner reinforcement in case of *Solid Concrete Block Masonry*

12.8.2 Vertical bars in Hollow Block Walls

Here cavities for locating the vertical bars are automatically available. Slit arrangement in the sides of the hollows for surrounding the bars will be required as shown in fig. 12.3.

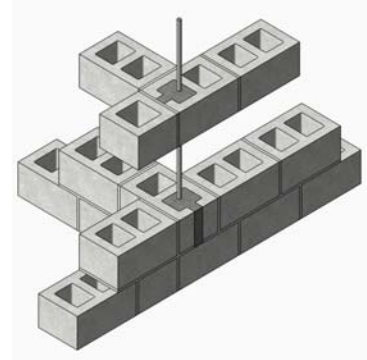
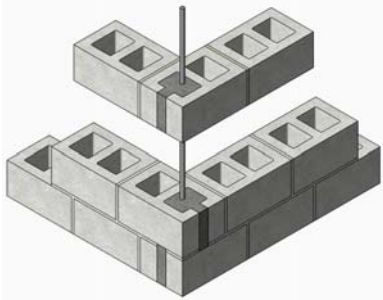

Fig.:12.3:- Corner reinforcement in case of *Hollow Concrete Block Masonry* (see the hole and slit made)

13. WOOD FRAMED WALLS

Timber has higher strength per unit weight and is, therefore, very suitable for earthquake resistant construction. Materials design and construction in timber shall generally conform to IS 883:1992. Timber construction shall generally be restricted to two storeys with or without the attic floor.

13.1 Foundations

Timber construction shall preferably start above the plinth level, the portion below being in masonry or concrete. The superstructure may be connected with the foundation in one of the two ways:

- A) The superstructure may simply rest on the plinth masonry, or in the case of small buildings of one storey having plan area less than 50 sq.m., it may rest on firm plane ground so that the building is free to slide laterally during ground motion
- B) The superstructure may be rigidly fixed into the plinth masonry or concrete foundation as shown in fig.13.1 or in case of small buildings it may be fixed to vertical poles embedded into the ground.

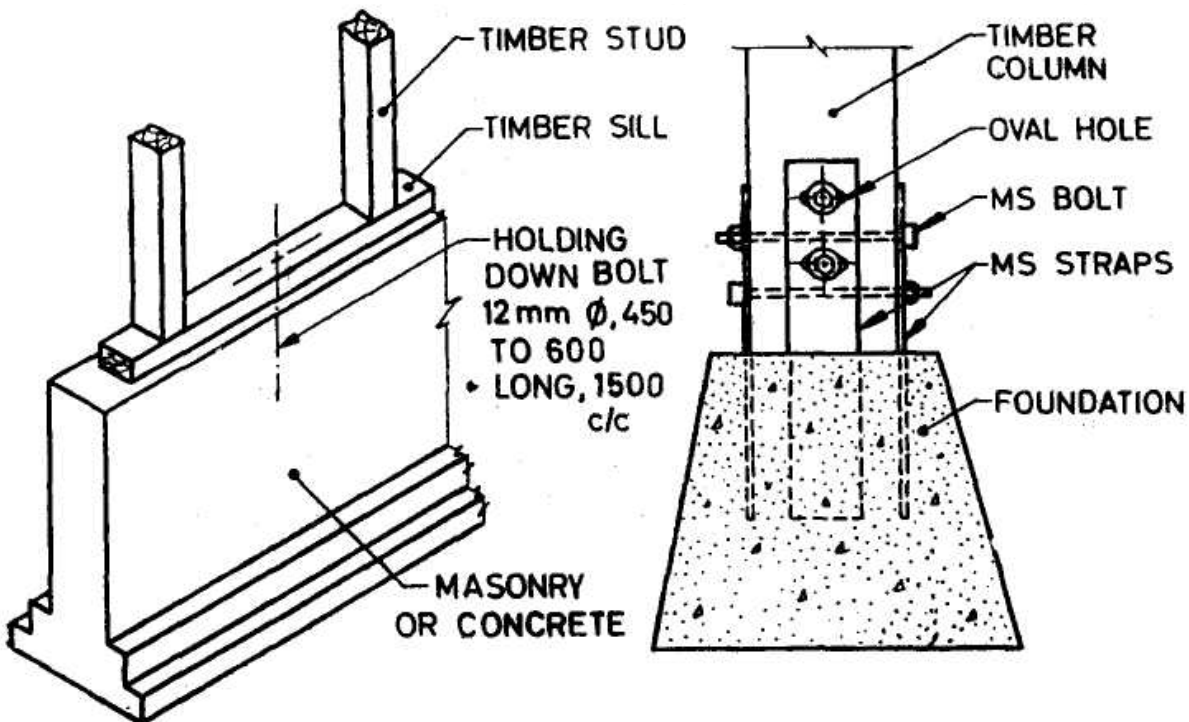

31A Suitable for Strip Foundations

31B Suitable for Isolated Column Footings

Fig. 13.1:- Details of connection of column with foundation

13.2 Types of Framing

The types of construction usually adopted in timber building are as follows:

A) **Stud wall construction:-** It consists of timber studs and corner posts framed into sills, top plates and wall plates. Horizontal struts and diagonal braces are used to stiffen the frame against lateral loads. The wall coverings may consist of EKRA, timber or like. Typical details are shown in fig. 13.2.

- Timber studs for use in load bearing walls shall have minimum finished size of 40X90 mm and their spacing shall not exceed those given in table 13.1
- There shall be atleast one diagonal brace for every 1.6X1 m area of load bearing walls. Their minimum finished sizes shall be in accordance to table 13.2
- The horizontal struts shall be placed not more than one metre apart. They will have a minimum size of 30 X 40 mm for all locations

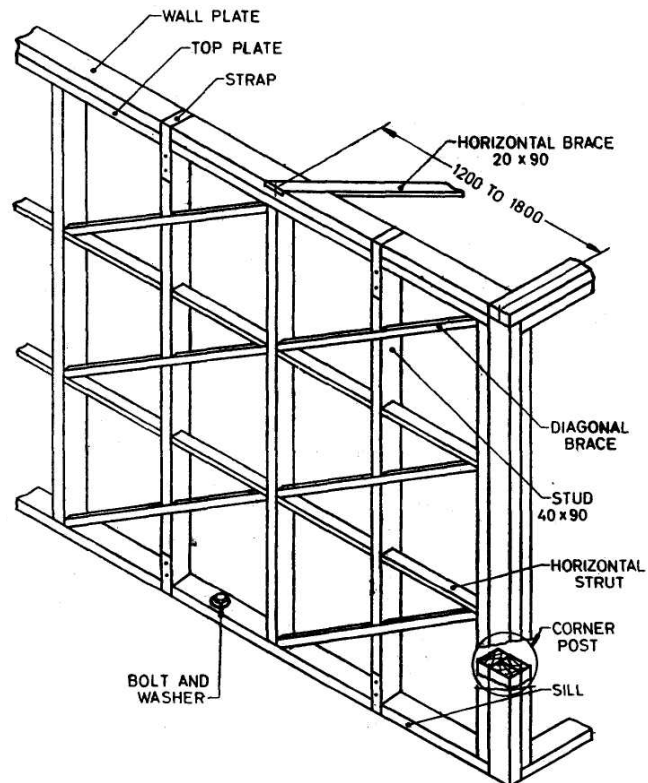

Fig.13.2:- Stud wall construction

Table 13.1 of 40X90 mm finished size studs in stud wall construction

Group Of Timber (Grade I*)	Single Storeyed Or First Floor Of The Double Storeyed Buildings		Ground Floor Of Double Storeyed Buildings	
	Exterior wall	Interior wall	Exterior wall	Interior wall
	cm	cm	cm	cm
Group A, B	100	80	50	40
Group C	100	100	50	50

* Grade I timber as defined in table 5 of IS 883:1992

Table 13.2:- Minimum finished sizes in diagonal braces

Building category	Group of timber (Grade I*)	Single storeyed or first floor of double storeyed buildings		Ground floor of double storeyed buildings	
		Exterior wall	Interior wall	Exterior wall	Interior wall
		mm x mm	mm x mm	mm x mm	mm x mm
D & E	Group A & B	20 x 40	20 x 40	20 x 40	30 x 40

* Grade I timber as defined in table 5 of IS 883:1992

- The corner post shall consist of three timber, two being equal in size to the studs used in the walls meeting at the corner and the third timber being of a size to fit so as to make a rectangular section (see fig. 13.3)
- The diagonal braces shall be connecte at their ends with the stud wall members by means of wire nails having 6 gauge (4.88 mm dia.) and 10 cm length. Their minimum number shall be 4 nails of 20 mm X 40 mm braces. The far end of nails may be clutched as far as possible.
- Horizontal bracing shall be provided at corners or T-junctions of walls at sill, first floor and eave levels. The bracing members shall have a minimum finished size of 20 mm X 90 mm and shall be connected by means of wire nails to the wall plates at a distance between 1.2 m and 1.8 m measured from the junction of the walls. There shall be a minimum number of six nails of 6 gauge (4.88 mm dia.) and 10 cm length with clutching as far ends.

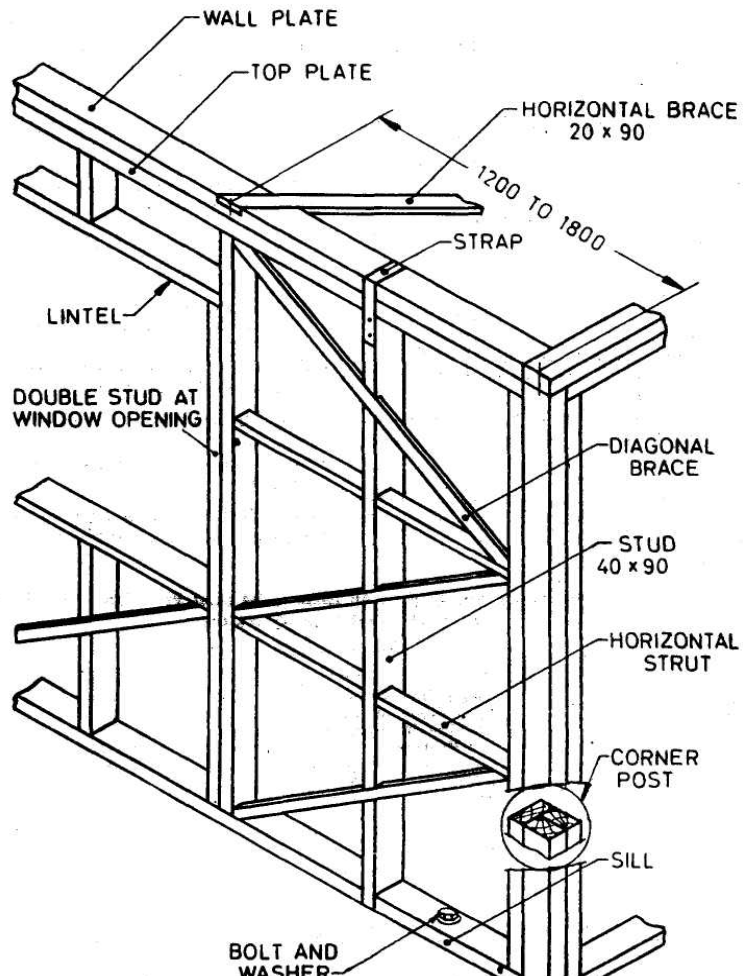

Fig.13.3:- Stud wall construction with opening in wall

B) Brick Nogged Timber Frame Construction:- It consist of verticals, columns sills, wall plates, horizontal nogging members and diagonal braces framed into each other and the space between framing members filled with tight-fitting brick masonry stretcher bond (see fig. 13.4)

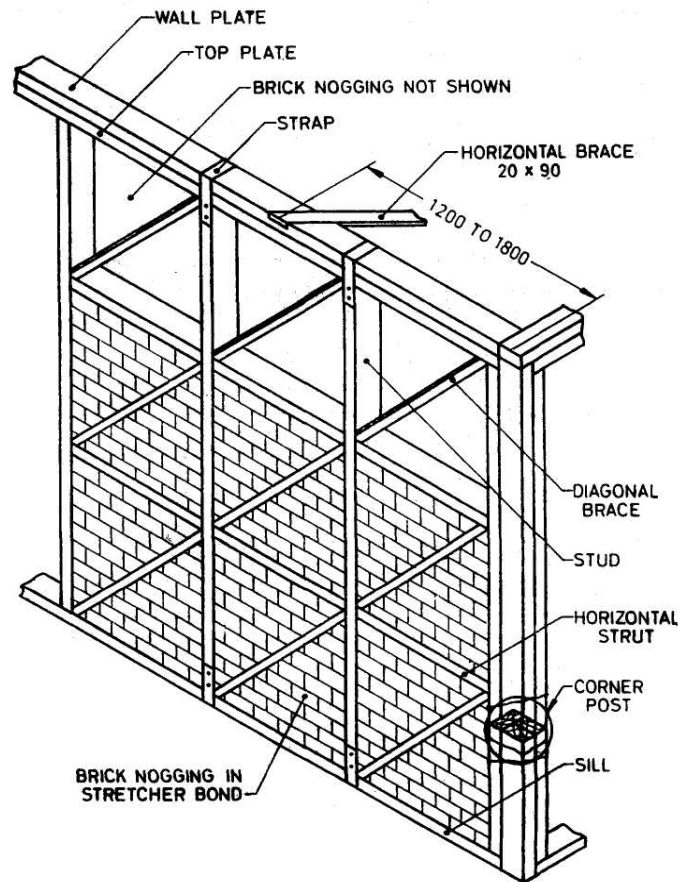

Fig.13.3:- Brick nogged timber frame construction

- The vertical framing members in brick nogged load bearing wall will have minimum finished sizes as specified in table 13.2.
- The minimum finished size of the vertical members in non-load bearing walls shall be 40 mm X 100 mm spaced not more than 1.5 m apart.
- The sizes of diagonal bracing members shall be the same as in table 13.2.
- The horizontal framing members in brick-nogged construction shall be spaced not more than 1 m apart. The minimum finished sizes shall be in accordance with table 13.3.
- Specification of corner post, connection of diagonal braces and horizontal bracing members at corners of T-junctions of wall shall be as detailed out previously in stud wall construction.

Table 13.3: Min. finished sizes of verticals in brick nogged timber frame construction

Spacing	Group of timber (Grade I*)	Single storeyed or first floor of double storeyed buildings		Ground floor of double storeyed buildings	
		Exterior wall	Interior wall	Exterior wall	Interior wall
m		mm x mm	mm x mm	mm x mm	mm x mm
1	Group A, B	50 X 100	50 X 100	50 X 100	50 X 100
	Group C	50 X 100	70 X 100	70 X 100	90 X 100
1.5	Group A, B	50 X 100	70 X 100	70 X 100	80 X 100
	Group C	70 X 100	80 X 100	80 X 100	100 X 100

* Grade I timber as defined in table 5 of IS 883:1992

14. ROOF

14.1 Sloping Wooden Roofs

The main load bearing structural members are timber trusses, purlins and bracings. The cladding may be of G.I or A.C. sheeting. Sloping roofs could be made with two slopes and gable ends or hipped type with four slopes (fig. 14.1). Against the earthquakes or wind storms, the four slope hipped roofs are stronger, hence safer.

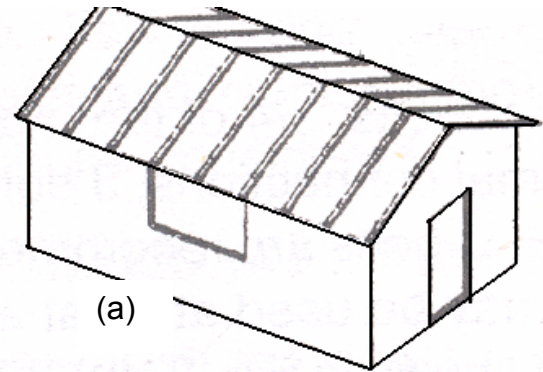

14.2 Roof Structure

The roof structure could be made using many rafters and battens or roof trusses with purlins. The C.G.I. sheeting is fixed to battens or purlins using J – bolts. (fig. 14.2)

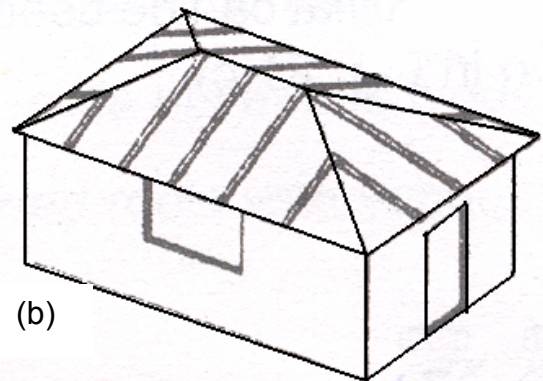

Fig. 14.1:- a) Two slopes with gable ends
b) Hipped type with four slopes

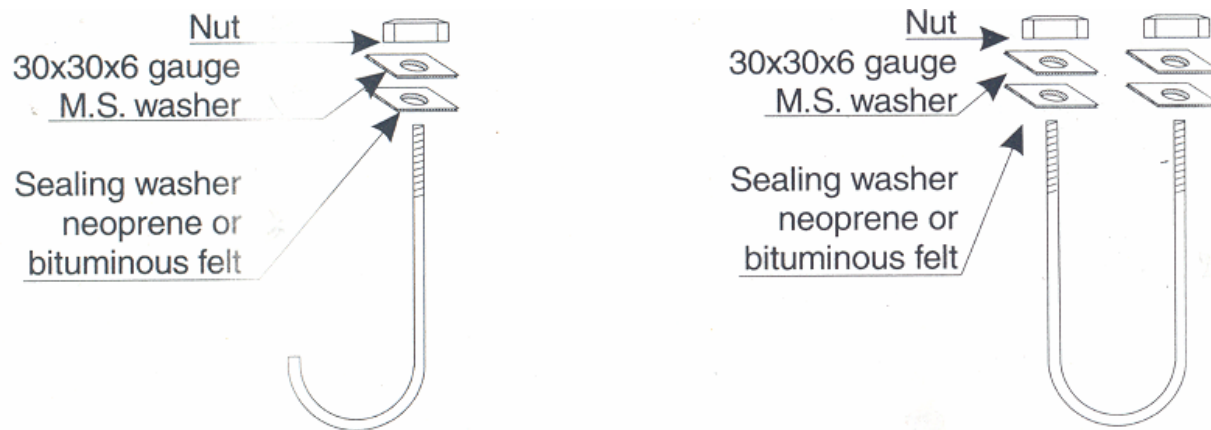

Fig. 14.2:- J & U bolt connection for roof cladding to purlins

The seismic resistance and wind resistance depends on the bracing system and strength of connections. The following are essential for achieving safety:-

- i. The main ties should be mutually connected by perpendicular elements, capable of acting as struts (compression members) provided at the nodes of the truss.
- ii. Cross bracing must be provided in the horizontal plane (in the plane of the main ties) throughout the truss-span.
- iii. Besides the bracing, to achieve a very suitable roof structure, the connections of purlins to the truss-rafters, and the various members of the bracing and roof trusses should be connected with each other quite rigidly, using atleast two bolts or nails at each joint and use of steel straps (see fig. 13.3).

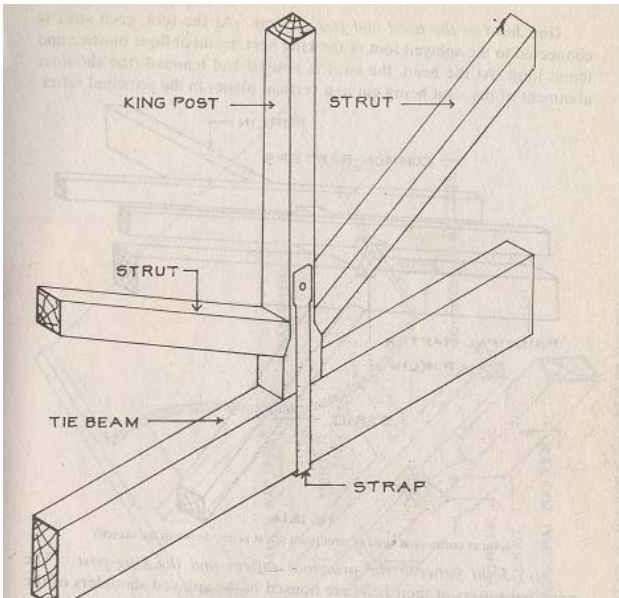

Fig.: 14.3:- View showing joint at the feet of the king post.

- iv. For holding down the sloping roof trusses the joists/rafters could be tied or nailed to the eave band/vertical wooden post (see fig. 14.4).

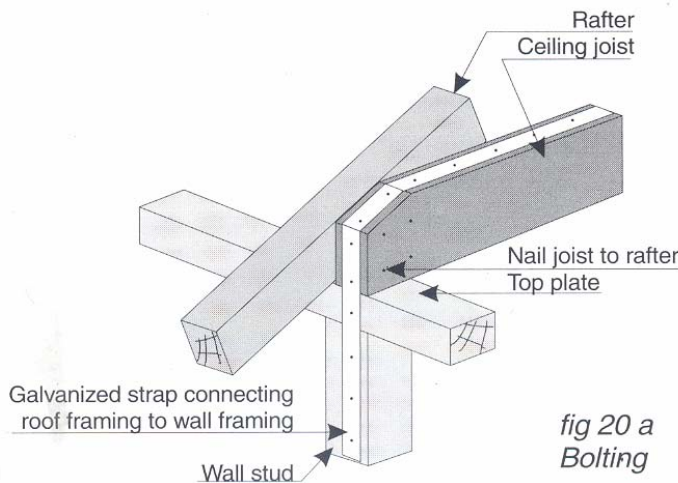

Fig.14.4:- Typical connection of wooden framing to wooden post