

Job Name: _____

Location: _____

Engineer: _____

Submitted to: _____

Submitted by: _____

Reference: _____

Date: _____

Approval: _____

Construction: _____

Unit #: _____

Drawing #: _____

KEY FEATURES:

- Auto-Swing for horizontal louvers
- Genius Core ultra-low compressor speed of 12Hz • 46° Freeze Protection
- Smart Kit Ready
- Turbo Mode
- Follow Me Mode
- Smart kit Included

NOTES:

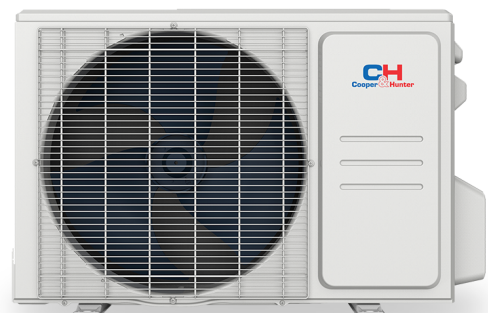
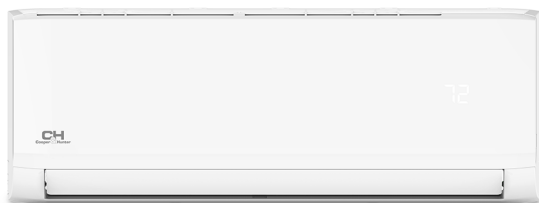

Indoor Model			CH-R18MOLVWM-230VI
Power supply		V, Ph, Hz	208-230V, 1Ph, 60Hz
Communication wiring			AWG 14-4
Cooling	Capacity	Btu/h	18,000 (3,600~20,000)
	Input	w	1,333 (355~1,700)
	Rated current	A	6 (1.6~7.5)
	EER/EER2	Btu/w	
	SEER/SEER2	Btu/w	
Heating at 47 °F	Capacity	Btu/h	18,800 (7,600~22,000)
	Input	W	1,385 (410~1,750)
	Rated current	A	6.2 (2.2~7.7)
	COP	W/W	3.81
	HSPF4/HSPF2-4		11.1
	HSPF5/HSPF2-5		8.3
Indoor fan motor		Qty	1
		Input	58
		RLA	0.8
Indoor air flow (Turbo/Hi/Med/Lo) (No duct)		CFM	759.3 / 500.3 / 441.4 / 370.8
ESP (range)		In.wg.	/
Indoor noise level (Hi/Med/Lo)		dB(A)	45/40/26/
Dehumidification		L/H	2.96
Indoor unit	Dimensions (WxDxH)	inch	42.60 x 9.21 x 13.27
	Packing (WxDxH)	inch	45.47 x 16.34 x 12.40
	Net/Gross weight	lbs	30.42/39.68
Drainage water pipe diameter		inch	5/8"
Refrigerant piping (Liquid side/Gas side)		inch	1/4"/1/2"
Design pressure		PSIG	550/340
Controller			remote controller
Room temperature	Cooling	F	60~90
	Heating	F	32~86

Outdoor Model			CH-RES18-230VO
Power supply		V, Ph, Hz	208-230V, 1Ph, 60Hz
Min. circuit ampacity		A	18
Max. fuse		A	20
Compressor	Model		KSN140D58UFZ
	Type		ROTARY
	Brand		GMCC
	Capacity	Btu/h	14.72
	Input	w	1.09
	Rated current (RLA)	A	10
	Refrigerant oil	oz	VG74 14.9
Outdoor fan motor	Qty		1
	Input	w	80
	RLA	A	0.9
	Speed	r/min	780/700/550
Outdoor air flow (Max)		CFM	1,764.7
Outdoor noise level (Max)		dB(A)	59
Throttle type			EXV+Throttle valve
Outdoor unit	Dimensions (WxDxH)	inch	35.04 x 13.46 x 26.5
	Packing (WxDxH)	inch	39.17 x 15.67 x 29.13
	Net/Gross weight	inch	92.59/100.31
Refrigerant	Type		R454B
	Precharge	ft	25
Additional charge for 1/4 inch liquid pipe		oz	0.16
Additional charge for 3/8 inch liquid pipe		oz	/
Refrigerant piping	Liquid side/Gas side	inch	1/4"/1/2"
	Max. pipe length	ft	98.4
	Max. difference in level	ft	65.6
Ambient temperature	Cooling	F	-13 ~ 122
	Heating	F	-13~75

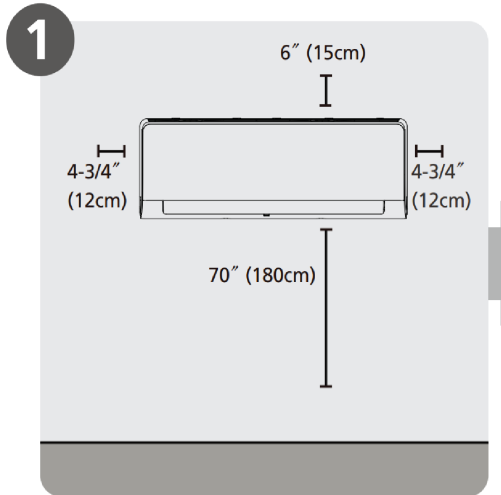

Select Installation Location

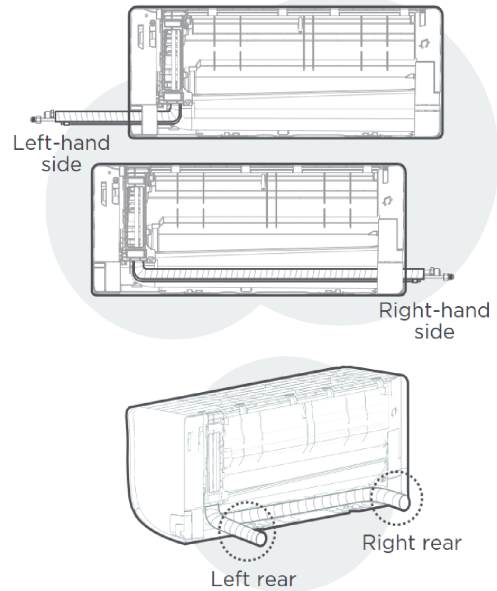

NOTE:

Based on the position of the wall hole relative to the mounting plate, choose the side from which the piping will exit the unit. You have four options for the exit direction of the piping.

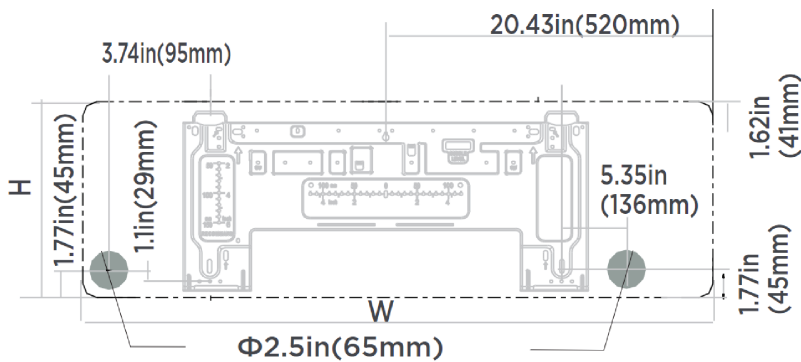

Indoor unit dimensions (WxH):
38.2in (971mm) x 12.6in (321mm)

NOTE:

When the gas side connective pipe is Φ (5/8in) 16mm or more, the wall hole should be (3-1/2in) 90mm.

