

Job Name:	
Submitted By:	



**Submittal Sheet For: CT012GLSILCFHG / YN012GLSI24RPG**

Date \_\_\_\_\_  
 Ref. \_\_\_\_\_

**Ceiling Cassette Ductless 21SEER Inverter Heat Pump**

System Full Set Model: **CYT012GLSI24RL**

AHRI Reference Number: **217048759**

**Cooling Mode Performance**

Rated Cooling	12,000 BTU/hr
Ambient Range	5~131°F
SEER2 Rating	21.0 BTU/W·h
EER2 Rating	11.7 BTU/W·h

\* 100% Capacity @ Indoor DB 80°F / WB 67°F

**Heating Mode Performance**

Rated Heating	12,000 BTU/hr
Ambient Range	-13~86°F
HSPF2 IV (V)	10.0 (8.9) BTU/W·h
COP2 (47°F)	3.5 W/W

Heating (17°F) = 10,500 BTU / Heating (5°F) = 9,000 BTU / COP2 (5°F) = 1.9 W/W



Ceiling Cassette Indoor Unit



Outdoor Condensing Unit



User-Selected Installation Kit



Handheld Remote Controller

**Electrical Information**

	Cooling	Heating
Rated Input (W)	980	960
Rated Current (A)	4.3	4.2
Breaker Needed	15A (Double-Pole)	
Power Supply	208~230V, 60Hz, 1Ph	

**Piping and Refrigerant**

Liquid Line (OD)	1/4 in
Suction Line (OD)	3/8 in
Refrigerant Precharge	R-454b(Supports 10-50 ft.)
Max Length/Height Diff.	50 ft. / 33 ft.

This combination is Energy-Star certified.



**Interior Unit (Air Handler) Specifications**

Type	Heat Pump
Sound Level (dBA)	46 (Turbo)/ 44 (Hi)/ 36 (Med)/ 32 (Lo)/ 30 (Mute)
Auto Air Circulation	2-Way Louver (Up-Down + Left-Right)
Dimensions (WDH)	22-1/2 in x 22-1/2 in x 9-5/8 in
Weight (lbs)	32

**Exterior Unit (Condenser) Specifications**

Sound Level (dBA)	52
Recommended Room Size	350~500 Sq. ft.
Minimum Room Size	40 Sq. ft.
Compressor	Inverter-Driven Rotary
Dimensions (WDH)	31-7/8 in x 12 in x 21-5/8 in
Weight (lbs)	58.4

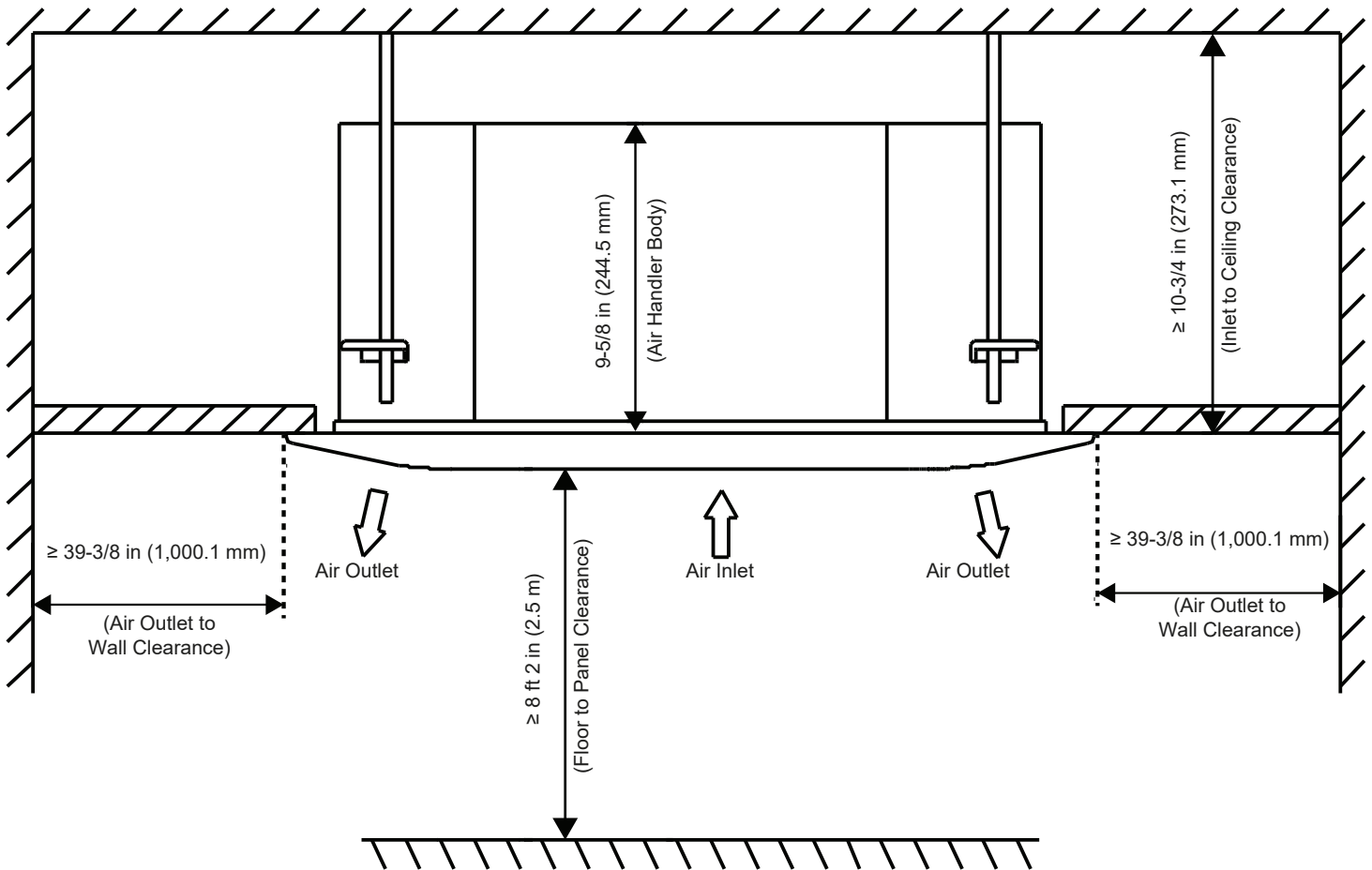
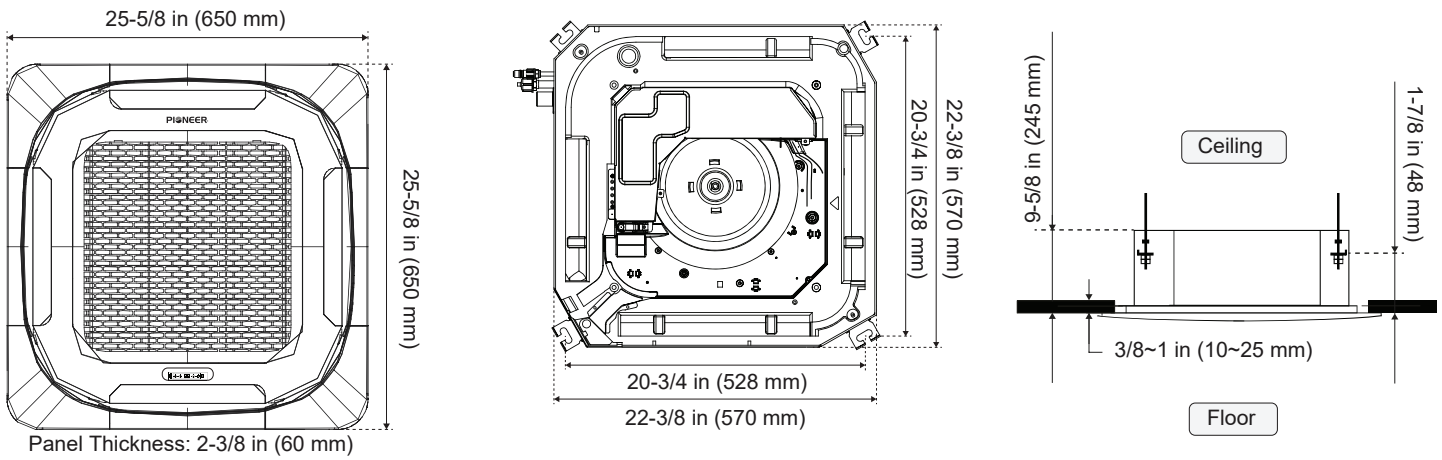

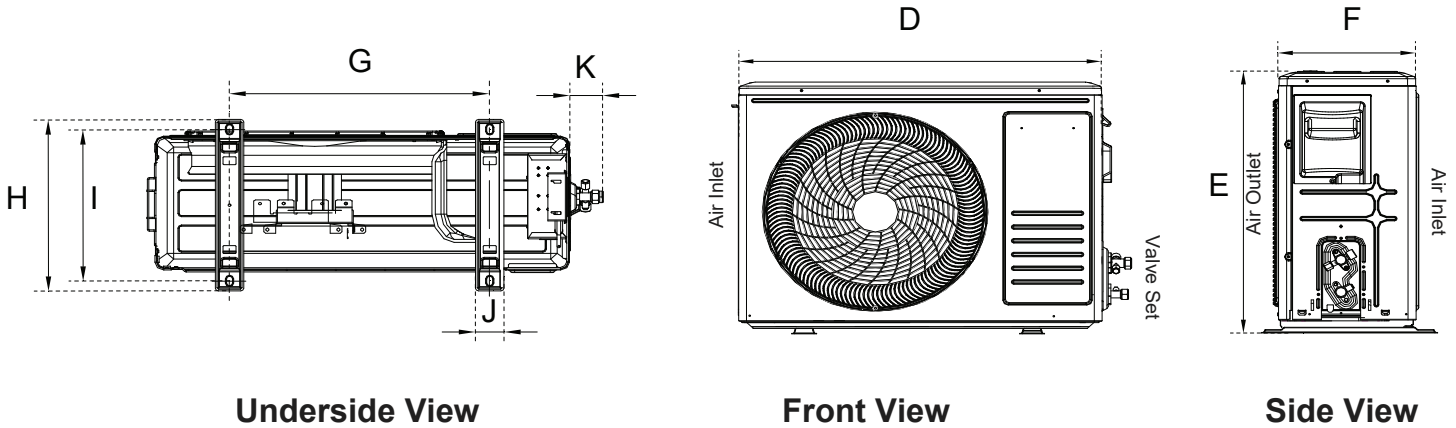

Model	D	E	F	G	H	I	J	K
YN012GLSI24RPG	29-1/8 in	21-3/4 in	10 in	17-1/8 in	12 in	11-1/4 in	1-7/8 in	2-1/4 in
	741 mm	551 mm	253 mm	434 mm	304.8 mm	285 mm	48 mm	58 mm

### Warranty Information and Length



Complete warranty details are available with the vendor or online at <https://www.pdhvac.com/support/warranty/>. This high quality system is eligible for up to 10 years limited warranty on the compressor, and 7 years on other internal parts. To qualify for this warranty, the system must be installed within 90 days by a registered technician. All other installations that are registered default to 5 years parts/compressor. Products unregistered qualify for only 1 year parts/compressor warranty.

### Outstanding Features

- LED Display
- Energy Saving
- Ultra-Thin Design
- Dual Drain Options
- Customizable Timer
- Eco-Friendly Refrigerant
- Whisper-Quiet Operation
- Power Loss Memory Recovery



### Available Accessories

Part Number	Description
IKT-LCVR4P-KIT	<i>Decorative PVC Line Cover Kit</i>
IKT-LNBR-1/4-3/8	<i>BendAid Flexible Easy Bender Kit</i>
BRK-FRM-C-2P	<i>Folding Mounting Bracket w/ Leveler</i>
IKT-UVL32UL-AG	<i>UVC Bacterial Disinfection Kit</i>
IKT-SURPRK-DV2	<i>Ultimate Surge and Power Protection</i>