

Job Name:	
Submitted By:	



**Submittal Sheet For: CT018GLSILCFHG / YN018GLSI24RPG**

Date \_\_\_\_\_  
 Ref. \_\_\_\_\_

**Ceiling Cassette Ductless 20SEER Inverter Heat Pump**

System Full Set Model: **CYT018GLSI24RL**

AHRI Reference Number: **217048760**

**Cooling Mode Performance**

Rated Cooling	16,000 BTU/hr
Ambient Range	5~131°F
SEER2 Rating	20.5 BTU/W·h
EER2 Rating	11.0 BTU/W·h

\* 100% Capacity @ Indoor DB 80°F / WB 67°F

**Heating Mode Performance**

Rated Heating	18,000 BTU/hr
Ambient Range	-13~86°F
HSPF2 IV (V)	8.5 (7.4) BTU/W·h
COP2 (47°F)	2.9 W/W

Heating (17°F) = 14,500 BTU / Heating (5°F) = 13,200 BTU / COP2 (5°F) = 1.8 W/W



Ceiling Cassette Indoor Unit



Outdoor Condensing Unit



User-Selected Installation Kit



Handheld Remote Controller

**Electrical Information**

	Cooling	Heating
Rated Input (W)	1,365	1,640
Rated Current (A)	5.9	7.1
Breaker Needed	20A (Double-Pole)	
Power Supply	208~230V, 60Hz, 1Ph	

**Piping and Refrigerant**

Liquid Line (OD)	1/4 in
Suction Line (OD)	1/2 in
Refrigerant Precharge	R-454b(Supports 10-50ft.)
Max Length/Height Diff.	65 ft. / 50 ft.

This combination is Energy-Star certified.



**Interior Unit (Air Handler) Specifications**

Type	Heat Pump
Sound Level (dBA)	50 (Turbo)/ 47 (Hi)/ 43 (Med)/ 38 (Lo)/ 34 (Mute)
Auto Air Circulation	2-Way Louver (Up-Down + Left-Right)
Dimensions (WDH)	22-1/2 in x 22-1/2 in x 9-5/8 in
Weight (lbs)	32

**Exterior Unit (Condenser) Specifications**

Sound Level (dBA)	53
Recommended Room Size	500~750 Sq. ft.
Minimum Room Size	51 Sq. ft.
Compressor	Inverter-Driven Rotary
Dimensions (WDH)	36-1/2 in x 15 in x 27-1/2 in
Weight (lbs)	90.4

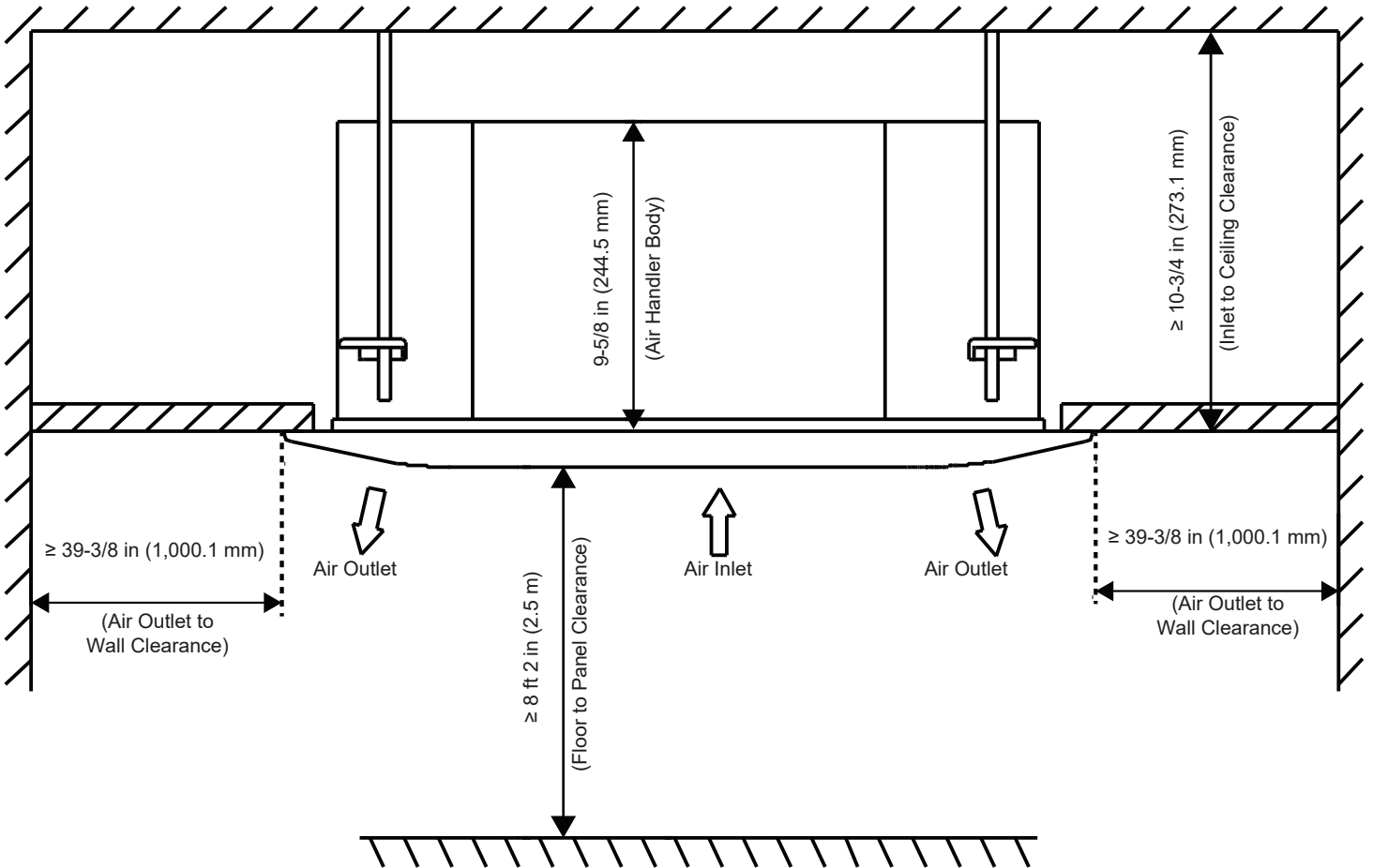
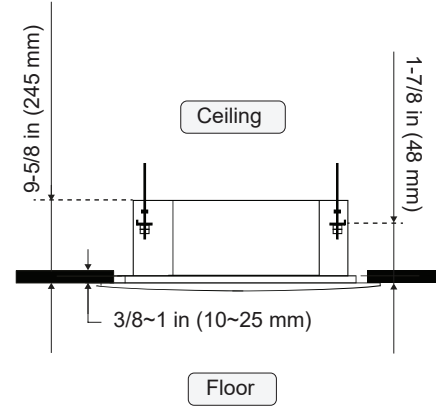
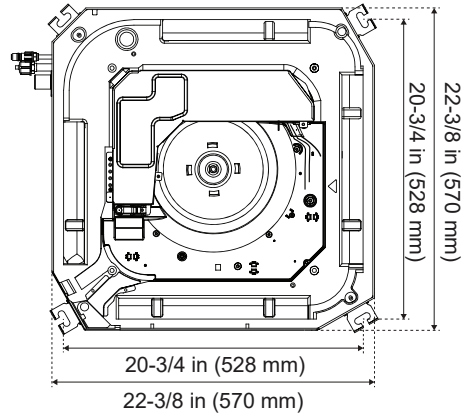
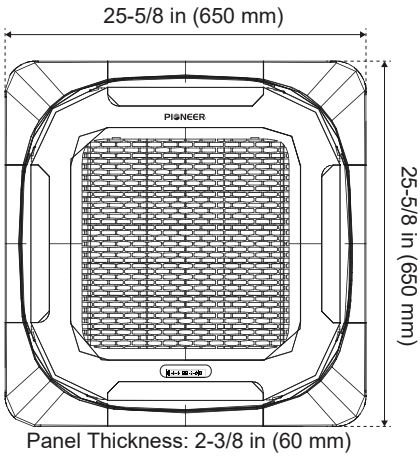

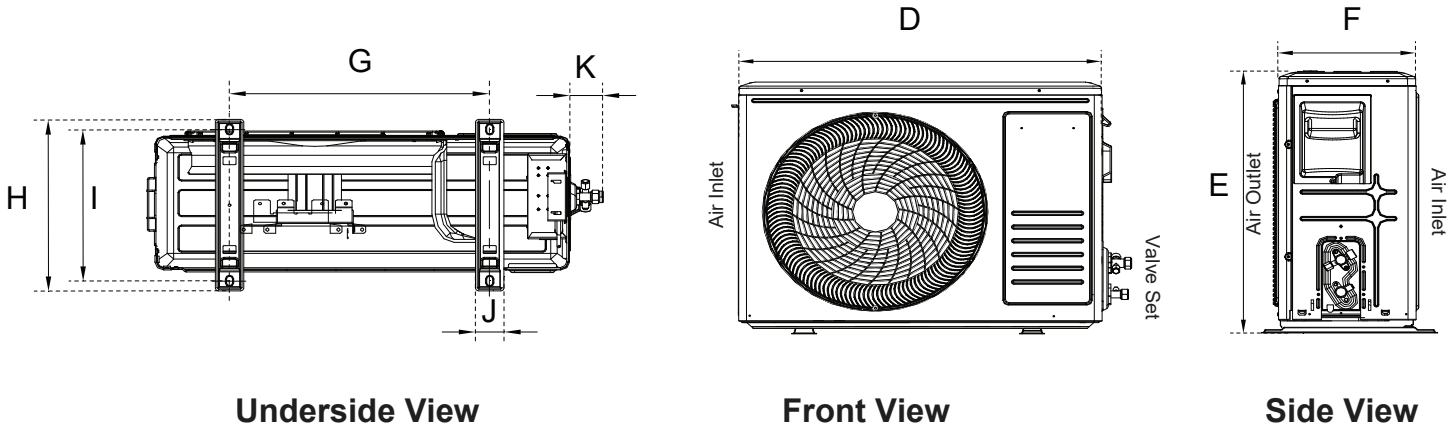

Model	D	E	F	G	H	I	J	K
YN018GLSI24RPG	33-1/4 in	27-1/2 in	12-7/8 in	23-1/8 in	14-3/4 in	13-3/4 in	2-1/8 in	2-1/4 in
	845 mm	699 mm	326 mm	586 mm	375 mm	348 mm	55 mm	55.9 mm

### Warranty Information and Length



Complete warranty details are available with the vendor or online at <https://www.pdhvac.com/support/warranty/>. This high quality system is eligible for up to 10 years limited warranty on the compressor, and 7 years on other internal parts. To qualify for this warranty, the system must be installed within 90 days by a registered technician. All other installations that are registered default to 5 years parts/compressor. Products unregistered qualify for only 1 year parts/compressor warranty.

### Outstanding Features

- LED Display
- Energy Saving
- Ultra-Thin Design
- Dual Drain Options
- Customizable Timer
- Eco-Friendly Refrigerant
- Whisper-Quiet Operation
- Power Loss Memory Recovery



### Available Accessories

Part Number	Description
IKT-LCVR4P-KIT	<i>Decorative PVC Line Cover Kit</i>
IKT-LNBR-1/4-3/8	<i>BendAid Flexible Easy Bender Kit</i>
BRK-FRM-C-2P	<i>Folding Mounting Bracket w/ Leveler</i>
IKT-UVL32UL-AG	<i>UVC Bacterial Disinfection Kit</i>
IKT-SURPRK-DV2	<i>Ultimate Surge and Power Protection</i>