

Job Name:	
Submitted By:	



<b>Submittal Sheet For:</b>	<b>CT024GLSILCFHG / YN024GLSI24RPG</b>
-----------------------------	--

Date \_\_\_\_\_  
 Ref. \_\_\_\_\_

**Ceiling Cassette Ductless 22SEER Inverter Heat Pump**

System Full Set Model: **CYT024GLSI24RL**

AHRI Reference Number: **217048761**

**Cooling Mode Performance**

Rated Cooling	23,000 BTU/hr
Ambient Range	5~131°F
SEER2 Rating	22.5 BTU/W·h
EER2 Rating	11.7 BTU/W·h

\* 100% Capacity @ Indoor DB 80°F / WB 67°F

**Heating Mode Performance**

Rated Heating	25,000 BTU/hr
Ambient Range	-13~86°F
HSPF2 IV (V)	10.4 (9.4) BTU/W·h
COP2 (47°F)	3.5 W/W

Heating (17°F) = 22,000 BTU / Heating (5°F) = 19,100 BTU / COP2 (5°F) = 2.0 W/W



Ceiling Cassette Indoor Unit



Outdoor Condensing Unit



User-Selected Installation Kit



Handheld Remote Controller

**Electrical Information**

	Cooling	Heating
Rated Input (W)	2,000	1,960
Rated Current (A)	8.7	8.5
Breaker Needed	25A (Double-Pole)	
Power Supply	208~230V, 60Hz, 1Ph	

**Piping and Refrigerant**

Liquid Line (OD)	1/4 in
Suction Line (OD)	5/8 in
Refrigerant Precharge	R-454b(Supports 10-50ft.)
Max Length/Height Diff.	65 ft. / 50 ft.

This combination is Energy-Star certified.



**Interior Unit (Air Handler) Specifications**

Type	Heat Pump
Sound Level (dBA)	50 (Turbo)/ 47 (Hi)/ 43 (Med)/ 38 (Lo)/ 34 (Mute)
Auto Air Circulation	2-Way Louver (Up-Down + Left-Right)
Dimensions (WDH)	33-1/8 in x 33-3/4 in x 10-3/4 in
Weight (lbs)	51.8

**Exterior Unit (Condenser) Specifications**

Sound Level (dBA)	54
Recommended Room Size	750~1,000 Sq. ft.
Minimum Room Size	62 Sq. ft.
Compressor	Inverter-Driven Rotary
Dimensions (WDH)	38-1/2 in x 16-5/8 in x 31-5/8 in
Weight (lbs)	104.7

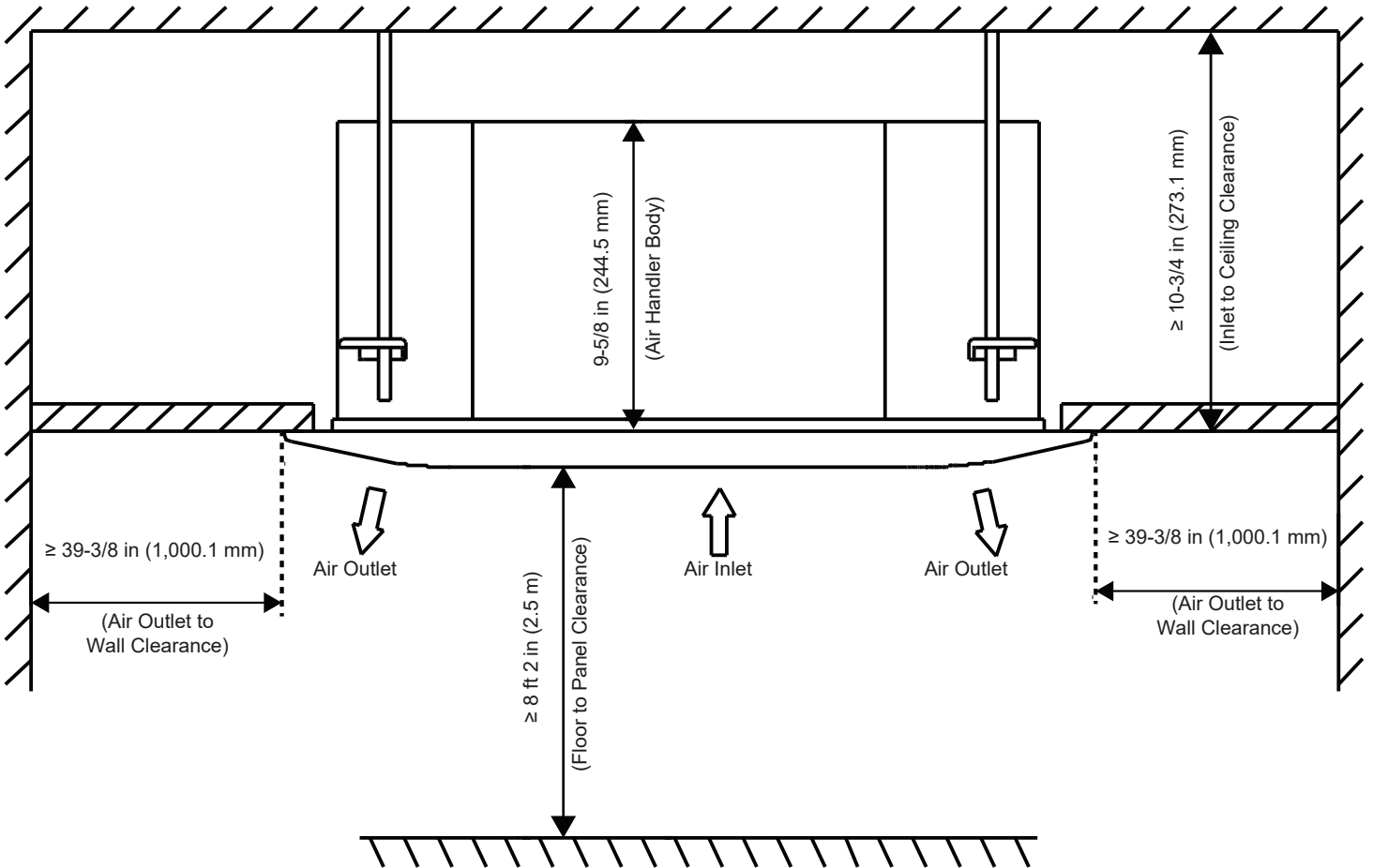
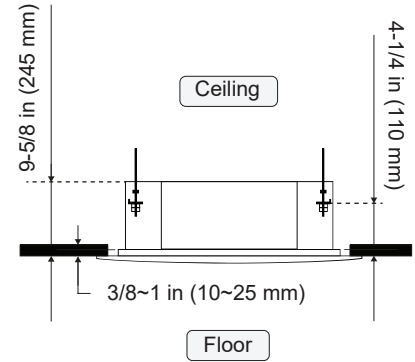
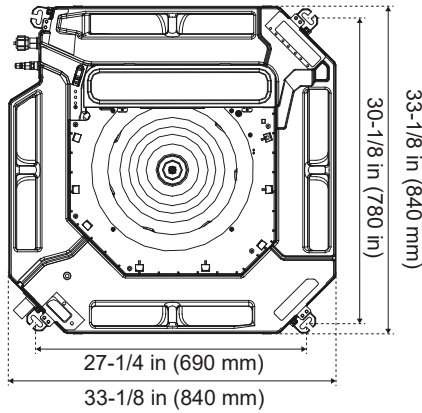
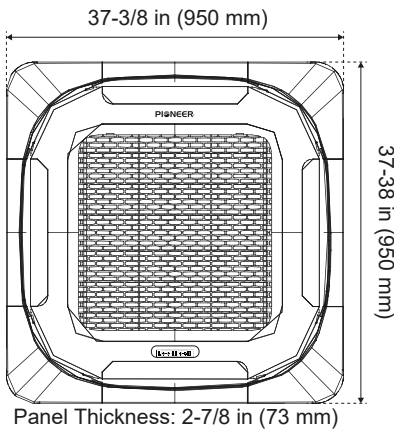

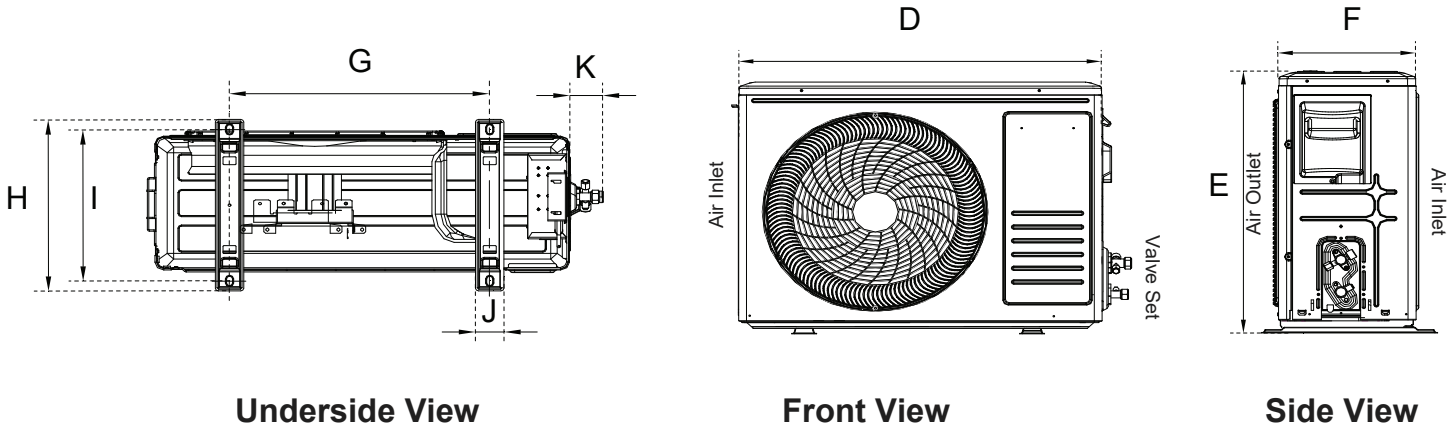

Model	D	E	F	G	H	I	J	K
YN024GLSI24RPG	35-7/8 in	31-5/8 in	14-1/8 in	23-7/8 in	16-5/8 in	15-3/8 in	2-3/8 in	2-1/2 in
	910 mm	803 mm	359 mm	607 mm	421 mm	390 mm	60 mm	63 mm

### Warranty Information and Length



Complete warranty details are available with the vendor or online at <https://www.pdhvac.com/support/warranty/>. This high quality system is eligible for up to 10 years limited warranty on the compressor, and 7 years on other internal parts. To qualify for this warranty, the system must be installed within 90 days by a registered technician. All other installations that are registered default to 5 years parts/compressor. Products unregistered qualify for only 1 year parts/compressor warranty.

### Outstanding Features

- LED Display
- Energy Saving
- Ultra-Thin Design
- Dual Drain Options
- Customizable Timer
- Eco-Friendly Refrigerant
- Whisper-Quiet Operation
- Power Loss Memory Recovery



### Available Accessories

Part Number	Description
IKT-LCVR4P-KIT	<i>Decorative PVC Line Cover Kit</i>
IKT-LNBR-1/4-3/8	<i>BendAid Flexible Easy Bender Kit</i>
BRK-FRM-C-2P	<i>Folding Mounting Bracket w/ Leveler</i>
IKT-UVL32UL-AG	<i>UVC Bacterial Disinfection Kit</i>
IKT-SURPRK-DV2	<i>Ultimate Surge and Power Protection</i>