

Low Static Ducted Slim Heat Pump Ductless System

Indoor Model: **D5FSDAH18XAK**

Job Data:
 Tag #:
 Date:

Location:
 Carrier#:



INDOOR STANDARD FEATURES

- Modes: Cool, Heat, Dry, Fan, Auto
- Vertical or Horizontal Installation
- Rear or Bottom Return
- Outside Air Intake
- Condensate Lift pump shipped with the unit
- Follow Me (senses temperature at handheld remote)
- Refrigerant Leak Detection Sensor
- Auto-Restart function
- Quiet indoor operation
- Anti-corrosive fin coating

LIMITED WARRANTY*

- Seven (7) years compressor and five (5) years parts warranty.

NOTE: Images for illustration purposes only. Actual models may be slightly different.

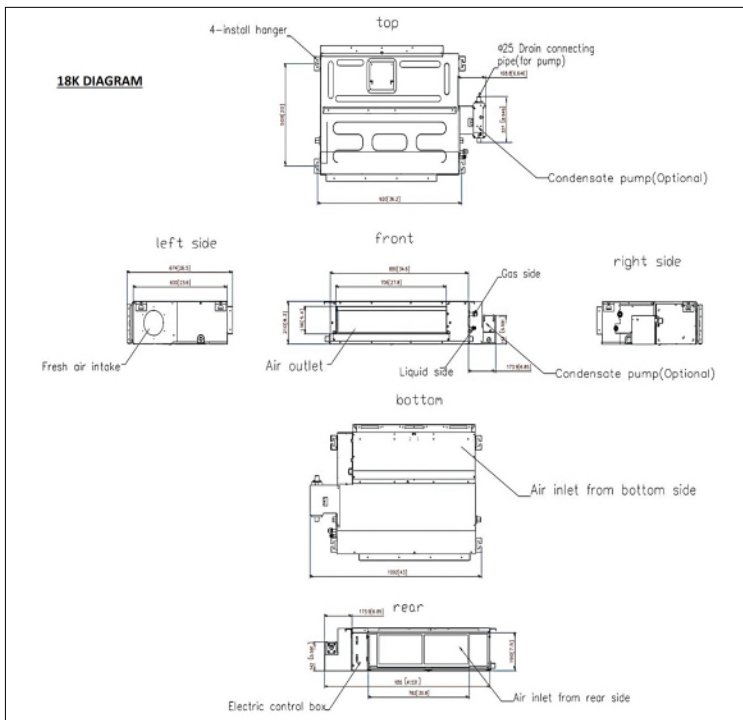
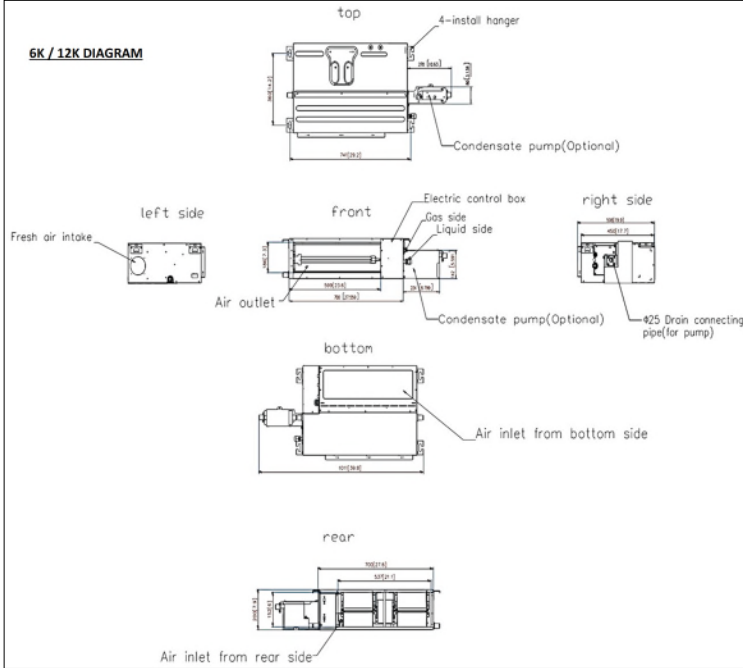

D5FSDAH18XAK			
System	Indoor Model #	D5FSDAH18XAK	
	Indoor Size	18000	
Electrical	Voltage, Phase, Cycle	208-230/1/60	
	Power Supply	Indoor unit powered by outdoor unit	
	MCA	A.	3
Piping	Pipe Connection Size - Liquid	in (mm)	1/4(6.35)
	Pipe Connection Size - Suction	in (mm)	1/2(12.7)
Operating Range	Cooling Indoor DB Min - Max	*F(*C)	60~90 (16~32)
	Heating Indoor DB Min - Max	*F(*C)	32~86 (0~30)
Indoor Coil	Face Area	Sq. Ft.	1.89
	No. Rows		3
	Fins per inch		18
	Circuits		4
Indoor Unit	Number of Fan Speeds	1100/900/700	
	Airflow (highest to lowest)	CFM	600.37 / 559.17 / 500.31 / 441.45 //
	Sound Pressure (highest to lowest)	dB(A)	N/A/40/39/38/32
Dimensions	Height	in (mm)	8.27(210)
	Width	in (mm)	34.65(880)
	Depth	in (mm)	26.54(674)
	Net Weight	lbs (kg)	54.45(24.7)
	Shipping Height	in (mm)	11.02(280)
	Shipping Width	in (mm)	42.13(1070)
	Shipping Depth	in (mm)	28.54(725)
	Shipping Net Weight	lbs (kg)	66.14(30)
	CONTROLS		
Standard	Wireless Remote Controller (*F/*C Convertible)		
	Wired Remote Control 7 Day Programmable	KSACN1401AAA	
Optional	Wired Remote Control with Timer Function	KSACN1201AAA	
	24V Mini Interface	KSAIC0601230	
	24V GEN 3 Interface	KSAIC0501230	

INDOOR UNIT DIMENSIONS				
Capacity	Unit	W	D	H
6K/12K	mm	700	506	200
	inch	27.56	19.92	7.87
18K	mm	880	674	210
	inch	34.65	26.54	8.27



R-454B