

Job Name:	
Submitted By:	



**Submittal Sheet For: WT012GLUI25FVQ / YN012GLUI25RPQ**

Date \_\_\_\_\_  
 Ref. \_\_\_\_\_

**Wall-Mounted Ductless Fresh Air Inverter Heat Pump**

System Full Set Model: **WYT012GLUI25FV**

AHRI Reference Number: **217048739**

**Cooling Mode Performance**

Rated Cooling	12,000 BTU/hr
Ambient Range	5~122°F
SEER2 Rating	24.0 BTU/W·h
EER2 Rating	13.0 BTU/W·h

\* 100% Capacity @ Indoor DB 80°F / WB 67°F

**Heating Mode Performance**

Rated Heating	13,100 BTU/hr
Ambient Range	-4~86°F
HSPF2 IV (V)	9.5 (8.5) BTU/W·h
COP2 (47°F)	4.2 W/W

Heating (17°F) = 8,000 BTU / Heating (5°F) = 10,100 BTU / COP2 (5°F) = 2.0 W/W



Wall-Mounted Indoor Unit



Outdoor Condensing Unit



User-Selected Installation Kit



Handheld Remote Controller

**Electrical Information**

	Cooling	Heating
Rated Input (W)	930	910
Rated Current (A)	4.4	4.2
Breaker Needed	15A (Double-Pole)	
Power Supply	208~230V, 60Hz, 1Ph	

**Piping and Refrigerant**

Liquid Line (OD)	1/4 in
Suction Line (OD)	3/8 in
Refrigerant Precharge	R-32 (Supports 10-50ft.)
Max Length/Height Diff.	50 ft. / 33 ft.

This combination is Energy-Star certified.



**Interior Unit (Air Handler) Specifications**

Type	Heat Pump
Sound Level (dBA)	44 (Turbo)/43 (Hi)/37 (Med)/32 (Lo)/30 (Mute)
Auto Air Circulation	2-Way Louver (Up-Down + Left-Right)
Dimensions (WDH)	36-1/4 in x 8-1/8 in x 12-1/4 in
Weight (lbs)	25.4

**Exterior Unit (Condenser) Specifications**

Sound Level (dBA)	53
Recommended Room Size	350~500 Sq. ft.
Minimum Room Size	25 Sq. ft.
Compressor	Inverter-Driven Rotary
Dimensions (WDH)	31-7/8 in x 12 in x 21-5/8 in
Weight (lbs)	55.1

# WT012GLUI25FVQ Air Handler Dimensional Data

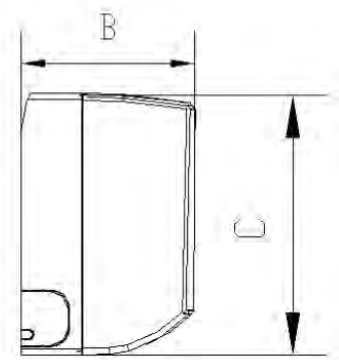
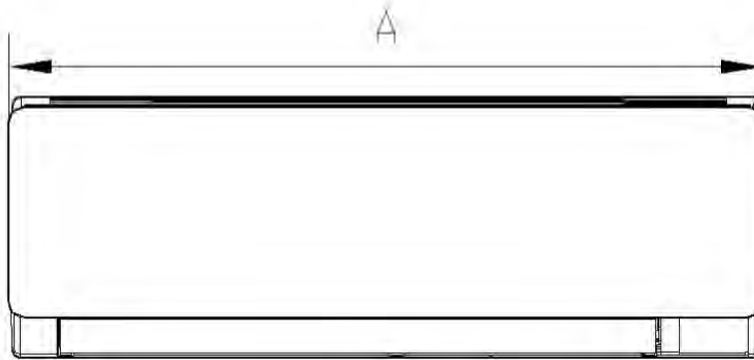
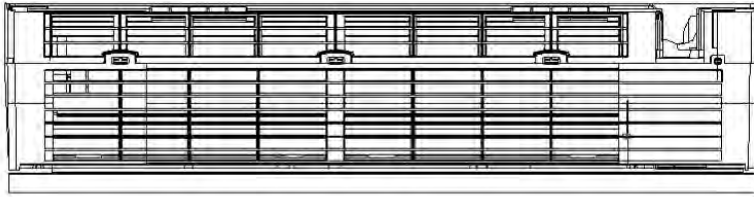

Model	A	B	C
WT012GLUI25FVQ	36-1/4 in	8-1/8 in	12-1/4 in
	920.8 mm	207 mm	311.2 mm

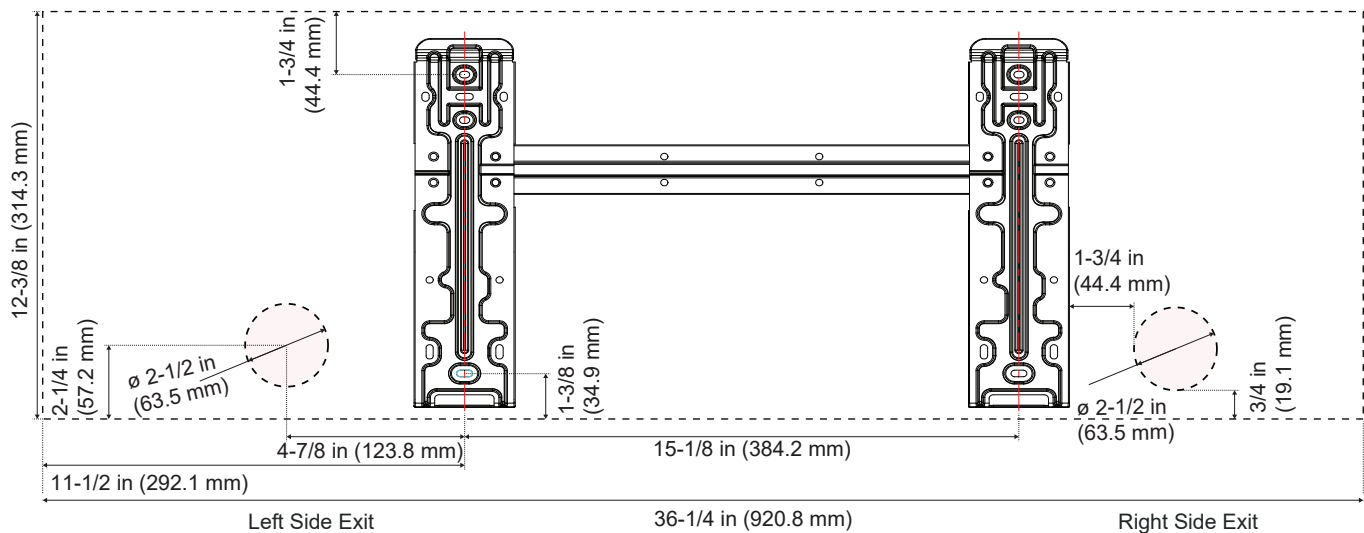

(For 12K Systems)  
All Distances in Inches

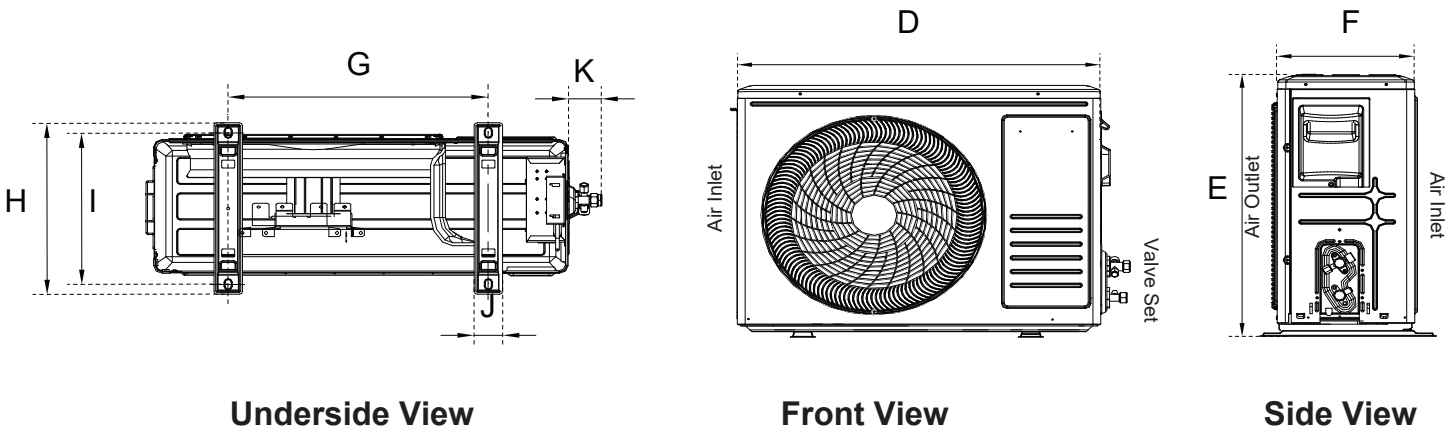

Model	D	E	F	G	H	I	J	K
YN012GLUI25RPQ	29-1/8 in	21-3/4 in	10 in	17-1/8 in	12 in	11-1/4 in	1-7/8 in	2-1/4 in
	741 mm	551 mm	253 mm	434 mm	304.8 mm	285 mm	48 mm	58 mm

### Warranty Information and Length



Complete warranty details are available with the vendor or online at <https://www.pdhvac.com/support/warranty/>. This high-quality system is eligible for up to a 5-year limited warranty on the compressor, and 5 years on other internal parts. To qualify for this warranty, the system must be installed within 90 days and registered properly. All other installations that are unregistered qualify for only 1-year parts/compressor warranty.

### Outstanding Features

- LED Display
- Energy Saving
- Ultra-Thin Design
- Customizable Timer
- Eco-Friendly Refrigerant
- Whisper-Quiet Operation
- Power Loss Memory Recovery



### Available Accessories

Part Number	Description
IKT-LCVR4P-KIT	<i>Decorative PVC Line Cover Kit</i>
IKT-LNBR-1/4-3/8	<i>BendAid Flexible Easy Bender Kit</i>
BRK-FRM-C-2P	<i>Folding Mounting Bracket w/ Leveler</i>
IKT-UVL32UL-AG	<i>UVC Bacterial Disinfection Kit</i>
IKT-SURPRK-DV2	<i>Ultimate Surge and Power Protection</i>