

PIONEER®

YNL-24 Multi-Zone Series

For 2/3/4/5-Circuit Systems

Quantum Ultra - WT/RT/UT/CT/FT Indoor and YN Outdoor

For Use with Designated Pioneer® Free-Match Air Handlers, as Add-On to Primary Manual

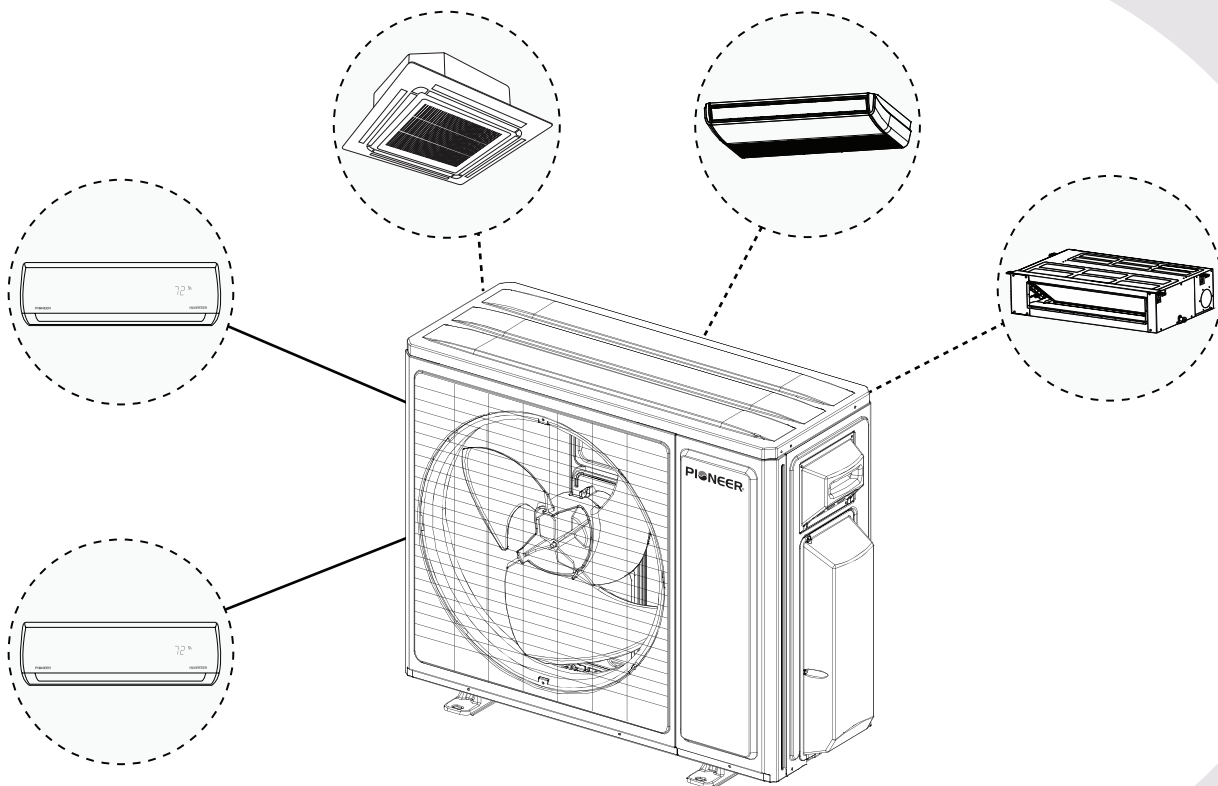

Addendum to Standard Manual (For Multi-Zone)

IMPORTANT NOTICE:

Read this manual carefully before installing or operating your new air conditioning system. Be sure to save this manual for future reference.



CONTENTS

1. Compatibility Information	2
2. A2L Refrigerants	3
3. Outdoor Section Installation	13
Appendix	19

Regarding the Scope of this Technical Document

Note Before Installation

This addendum is intended to supplement the standard **Installation and User Manual** included with each indoor unit when it is used as part of a **Multi-Zone Split System**. While the overall installation process closely resembles the single-zone system, multi-zone setups involve additional or repeated steps. Refer to the information in this document for the specific process used when completing a multi-zone installation. Read both manuals in full.

Note Regarding Compatibility

To ensure proper performance, safety, and warranty coverage, this outdoor section must only be used with designated Pioneer® brand indoor units that are explicitly approved for use within this product line. While only specific model combinations are currently supported, additional compatible indoor unit type may be introduced in future product releases.

Always consult the latest official Pioneer® multi-zone system compatibility chart or relevant technical documentation before configuring or installing a multi-split system.

1

Compatibility Information

Allowable Zone Combinations for Multi-Circuit Systems

Outdoor Unit Model Number	YN020GLSI24M2G	YN030GLSI24M3G	YN040GLSI24M4G	YN050GLSI24M5G
Number of Available Zones	Two (2)	Three (3)	Four (4)	Five (5)
Two Zones Utilized (Allowable Combinations in kBTU)	9 + 9 12 + 9 12 + 12 18 + 9	9 + 9 12 + 9 18 + 9 24 + 9 12 + 12 18 + 12 24 + 12 18 + 18	9 + 9 12 + 9 18 + 9 24 + 9 12 + 12 18 + 12 24 + 12 18 + 18 24 + 18 24 + 24	9 + 9 12 + 9 18 + 9 24 + 9 12 + 12 18 + 12 24 + 12 18 + 18 24 + 18 24 + 24
Three Zones Utilized (Allowable Combinations in kBTU)		9 + 9 + 9 12 + 9 + 9 18 + 9 + 9 12 + 12 + 9 18 + 12 + 9 12 + 12 + 12	9 + 9 + 9 9 + 9 + 12 9 + 9 + 18 9 + 12 + 12 9 + 12 + 18 9 + 12 + 24 12 + 12 + 12 12 + 12 + 18 12 + 12 + 24 12 + 18 + 18	9 + 9 + 9 12 + 9 + 9 18 + 9 + 9 12 + 12 + 9 18 + 12 + 9 24 + 12 + 9 18 + 18 + 9 24 + 18 + 9 24 + 24 + 9 12 + 12 + 12 18 + 12 + 12 24 + 12 + 12 18 + 18 + 12 24 + 18 + 12 24 + 24 + 12 18 + 18 + 18 24 + 18 + 18
Four Zones Utilized (Allowable Combinations in kBTU)			9 + 9 + 9 + 9 12 + 9 + 9 + 9 18 + 9 + 9 + 9 12 + 12 + 9 + 9 18 + 12 + 9 + 9 12 + 12 + 12 + 9 18 + 12 + 12 + 9 24 + 12 + 12 + 9 24 + 18 + 12 + 9 12 + 12 + 12 + 12 18 + 12 + 12 + 12 24 + 12 + 12 + 12 18 + 18 + 12 + 12	9 + 9 + 9 + 9 12 + 9 + 9 + 9 18 + 9 + 9 + 9 12 + 12 + 9 + 9 18 + 12 + 9 + 9 12 + 12 + 12 + 9 18 + 12 + 12 + 9 24 + 12 + 12 + 9 24 + 18 + 12 + 9 12 + 12 + 12 + 12 18 + 12 + 12 + 12 24 + 12 + 12 + 12 18 + 18 + 12 + 12
Five Zones Utilized (Allowable Combinations in kBTU)				9 + 9 + 9 + 9 + 9 12 + 9 + 9 + 9 + 9 18 + 9 + 9 + 9 + 9 24 + 9 + 9 + 9 + 9 12 + 12 + 9 + 9 + 9 18 + 12 + 9 + 9 + 9 24 + 12 + 9 + 9 + 9 18 + 18 + 9 + 9 + 9 12 + 12 + 12 + 9 + 9 18 + 12 + 12 + 9 + 9 12 + 12 + 12 + 12 + 9 18 + 12 + 12 + 12 + 9 18 + 12 + 12 + 12 + 9 12 + 12 + 12 + 12 + 12

- Different models of all available matching indoor units can be combined in any order to create a multi-zone split system, up to the number of available circuits.
- Not all available circuits need to be utilized with an attached indoor unit. 66% or higher of the total capacity utilization is recommended.
- Every indoor unit attached to a multi-zone system will operate at a random, self-regulated capacity. The operation is based on the actual demand it measures from the zone it is serving (between 30-100% of its rated capacity) or turn off as needed.
- Outdoor units will also self-regulate their total output capacity, based on the total demand it reads from all of the simultaneously running indoor units at any given moment (up to its maximum rating capacity).
- With multi-split systems, the total demand from the outdoor unit will rarely exceed 75% of the total available capacity of the combined indoor unit group due to load fluctuations of each indoor unit.
- Therefore, the total attached indoor unit can be selected up to 133% of the supporting outdoor unit's rated capacity.
- Although rare, if the total demand from the combined group of indoor units exceeds the rated capacity of the outdoor unit, the capacity of each indoor unit will be reduced proportionally.
- For high demand applications, max loading limits may need to be reduced up to 20% to avoid underperformance risks during extreme conditions.
- The BTU order of attached indoor units has no effect on performance.

A2L Refrigerants

2

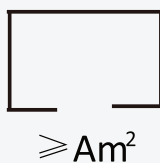

A2L



Safety Information for A2L Refrigerants

Because the system contains R-454B refrigerant, read and observe the following notices. Note that venting any type of refrigerant into the atmosphere is always illegal and punishable under federal and local regulations. Always read and obey all applicable local EPA laws.

- Refer to this manual for the required installation space dimensions, including the minimum clearance distances from adjacent structures.
 - Install, operate, and store the appliance in a room following the minimum room area requirements.
 - Keep the length of the refrigerant piping to a minimum.
 - Protect the refrigerant piping from physical damage. In addition, if the area of the space is smaller than the minimum, ensure the installation occurs in a ventilated space.
 - Ensure the installation complies with all applicable national refrigerant regulations.
 - Ensure all mechanical connections remain accessible for maintenance.
 - Follow the instructions in this manual for proper handling, installation, cleaning, maintenance, and disposal of the refrigerant.
 - Confirm that all ventilation openings remain unobstructed.
- ⚠ Perform the servicing only in accordance with the manufacturer's recommendations.
 - ⚠ Store the appliance in a well-ventilated area with a room size that meets the minimum requirements specified for operation.
 - ⚠ Store the appliance in a room free of continuously operating open flames (e.g., an active gas appliance) and ignition sources (e.g., an operating electric heater).
 - Individuals working on refrigerant circuits must hold a valid, up-to-date certification from an industry-accredited assessment authority. They must verify their competence in handling refrigerants per the recognized assessment specifications of the relevant industrial sector.
 - Perform service operations strictly in accordance with the manufacturer's recommendations.
 - If maintenance and repairs require assistance from additional qualified personnel, conduct the tasks under the supervision of a certified professional competent in handling flammable refrigerants.

A2L Refrigerants

2

Servicing Information for A2L Refrigerants

- Store the appliance in a manner that prevents mechanical damage.
- Competent personnel must carry out any work procedures affecting safety measures.



Warning

- Do not attempt to accelerate the defrosting process or remove frost manually.
- Follow the manufacturer's recommended procedures.
- Store the appliance in a room free of continuously operating ignition sources (e.g., open flames, active gas appliances, operating electric heaters).
- Do not pierce or incinerate the appliance or its components.
- Be aware that refrigerants may be odorless.
- **Area Inspection:**
 - Before servicing systems containing flammable refrigerants, perform safety checks to minimize the risk of ignition. When repairing the refrigeration system, observe all the following precautions before beginning any work.
- **Work Procedure:**
 - Conduct all work under a controller process to minimize the risk of flammable gas or vapor from being present during servicing.
- **General Work Area**
 - Inform all maintenance personnel and individuals in the vicinity about the nature of the work being performed.
 - Avoid working in confined spaces whenever possible.
 - Section off the work area to prevent unauthorized access.
- **Area Ventilation:**
 - Ensure the area is free from flammable materials and that conditions are controlled to maintain a safe working environment.
- **Checking for Refrigerant Presence:**
 - Monitor the work area for refrigerant leaks using an appropriate refrigerant detector before and during servicing.
 - Ensure the leak detection equipment used is suitable for flammable refrigerants (i.e., non-sparking, adequately sealed, or intrinsically safe).
- **Presence of Fire Extinguisher:**
 - If performing any hot work on the refrigeration equipment or its associated components, ensure appropriate fire extinguishing equipment is readily available. Position a dry powder or CO₂ fire extinguisher adjacent to the charging area.
- **Elimination of Ignition Sources:**
 - Do not use ignition sources that could pose a fire or explosion risk when conducting any work involving the exposure of refrigeration system piping.
 - Keep all potential ignition sources, including smoking, at a safe distance from the installation, repair, removal, disposal areas, and locations where refrigerant may be released unintentionally into the surrounding space.
 - Before commencing work, inspect the area to ensure that no flammable hazards or ignition risks are present.
 - Clearly display "No Smoking" signs in the work area.

A2L Refrigerants

2

Service Information for A2L Refrigerants (Continued)

- **Ventilated Area:**

- Ensure the work is conducted in either an open area or in a space with adequate ventilation before breaking into the system or performing any heat-producing tasks.
- Maintain ventilation throughout the duration of the work.
- Ensure the ventilation system effectively disperses any released refrigerant and directs it safely to an external atmosphere, if possible.

- **Inspection of Refrigeration Equipment:**

- When replacing electrical components, ensure that they meet the correct specifications and are suitable for its intended purpose.
- Follow the manufacturer's maintenance and service guidelines.
- If unsure, consult the manufacturer's technical support department for guidance.

- **Inspections for Installations Using Flammable Refrigerants:** Perform the following inspections for systems utilizing flammable refrigerants:

- Ensure that the refrigerant charge size complies with the minimum room size requirements when installing refrigerant-containing components.
- Verify that the ventilation equipment and exhaust outlets are functioning properly and free from obstructions.
- If using an indirect refrigerant circuit, inspect the secondary circuit for any presence of refrigerant.
- Confirm that all equipment markings remain visible and legible. Replace or correct any illegible markings or signs.

- Install the refrigeration piping and components in locations where they are not exposed to substances that could cause corrosion. If exposure is unavoidable, verify that the components are either made from corrosion-resistant materials or are adequately protected against corrosion.

- **Inspection of Electrical Devices:**

- Ensure the repair and maintenance of electrical components include initial safety checks and a thorough inspection of components.
- If the fault cannot be corrected immediately but continuing work is necessary, implement a temporary solution that is safe and effective.
- Report any temporary measures to the equipment owner, ensuring all relevant parties are informed.

- **Initial Safety Checks:**

- Fully discharge the capacitors in a controlled manner to prevent sparking.
- Verify that no live electrical components or exposed wiring are present during system charging, refrigerant recovery, or purging.
- Confirm that the earth bonding continuity is maintained.

- **Repairs to Sealed Components:**

- Replace sealed electrical components, rather than repair them.

- **Repairs to Intrinsically Safe Components:**

- Replace intrinsically safe components, rather than repair them.

A2L Refrigerants

2

Service Information for A2L Refrigerants (Continued)

- **Cabling:** Do not expose the cabling to wear, corrosion, excessive pressure, vibration, sharp edges, or other adverse environmental factors. Consider the long-term effects of aging and continuous vibration from components such as compressors or fans.
- **Detection of Flammable Refrigerants:** Do not use potential sources of ignition for refrigerant leak detection under any circumstances.
- **Leak Detection Methods:** The following methods are approved for detecting leaks in systems containing flammable refrigerants:
 - **Electronic Leak Detectors:** Use this method for detecting flammable refrigerants. **Note:** They may require recalibration to maintain adequate sensitivity.
 - Calibrate the detection equipment in a refrigerant-free area.
 - Ensure that the detector does not pose an ignition risk and is compatible with the refrigerant in use.
 - Set the detector to a percentage of the refrigerant's Lower Flammability Limit (LFL). In addition, calibrate the detector to confirm that the appropriate gas concentration does not exceed 25% of the LFL.
 - **Leak Detection Fluids:** This method is suitable for most refrigerants but must not contain chlorine. **Note:** Chlorine can react with the refrigerant and corrode copper piping.
 - **Safety Precautions:** If a leak is suspected, remove or extinguish all open flames. If a refrigerant leak requiring brazing is detected, fully recover the refrigerant or isolate the refrigerant using the shut-off valves to prevent accidental release.
 - **Oxygen-Free Nitrogen:** Purge oxygen-free nitrogen through the system before and during brazing.
- **Removal and Evacuation:** When accessing the refrigerant circuit for repairs or other procedures, follow the industry-standard practices, with additional precautions for flammability:
 1. Recover the refrigerant into approved recovery cylinders.
 2. Purge the circuit using an inert gas, such as OFN.
 3. Evacuate the system.
 4. Purge the circuit again using inert gas.
 5. Open the circuit by cutting or brazing.
 - Flush the system with OFN to ensure safety. Repeat this process multiple times if needed.
 - Do not use compressed air or oxygen for flushing.
- **Flushing:** Follow this flushing procedure:
 1. Break the system vacuum with OFN.
 2. Fill the system until the working pressure is reached.
 3. Vent the system to atmospheric pressure.
 4. Pull the system down to vacuum.
 5. Repeat this process until no refrigerant remains in the system.
 6. When the final OFN charge is introduced, vent the system to atmospheric pressure to allow for safe work. This step is critical before performing any brazing on pipework.

Note: Position the vacuum pump outlet away from ignition sources and ensure adequate ventilation.

A2L Refrigerants

2

Decommissioning Information for A2L Refrigerants

Decommissioning: Before starting decommissioning, the technician must be fully familiar with the equipment and its components. Safely recover all refrigerant as a standard best practice. Prior to decommissioning, collect an oil and refrigerant sample for analysis if reclaimed refrigerant is intended for reuse. Ensure electrical power is available before beginning the decommissioning process.

A. Familiarization: Understand the equipment, its operation, and the decommissioning process before beginning work.

B. Electrical Isolation: Disconnect the system from the electrical supply to prevent accidental activation during the procedure.

C. Pre-Procedure Safety Checks: Before proceeding, ensure the following:

- Mechanical handling equipment is available if needed for refrigerant cylinder transport.
- All required personal protective equipment (PPE) is present and correctly used.
- A competent person supervises the entire refrigerant recovery process.
- Recovery equipment and cylinders comply with all relevant safety and regulatory standards.

D. Pump Down the Refrigerant System: If possible, perform a pump-down procedure to remove refrigerant from the system.

E. Alternative Method if Vacuum is Not Possible: If a complete vacuum cannot be achieved, create a manifold to facilitate refrigerant removal from multiple points in the system.

F. Cylinder Positioning: Ensure the recovery cylinder is placed on a scale before starting the refrigerant recovery process.

G. Recovery Machine Operation: Start the recovery machine and follow the manufacturer's instructions for proper operation.

H. Cylinder Fill Limits: Do not exceed 80% of the cylinder's total volume when filling with liquid refrigerant, allowing expansion.

I. Maximum Pressure Precautions: Do not exceed the maximum working pressure of the recovery cylinder at any time, even temporarily.

J. Finalizing the Recovery Process:

- Once the cylinders are correctly filled and the process is complete:
 - Promptly remove the cylinders and recovery equipment from the site.
 - Close all isolation valves on the equipment to prevent leaks.

K. Handling Recovered Refrigerant: Recovered refrigerant must not be recharged into another refrigeration system unless it has been properly cleaned and tested to ensure compliance with safety and performance standards.

L. Labeling: Label the equipment indicating that it has been decommissioned and emptied of refrigerant. The label must include the decommissioning date and the signature of the responsible technician. Ensure that the equipment preserves labels indicating the presence of flammable refrigerant, even after decommission.

A2L Refrigerants

2

Recovery Information for A2L Refrigerants

Recovery Procedure: When removing refrigerant from a system for servicing or decommissioning, observe the following best practices to ensure safety and compliance:

1. Safe Refrigerant Removal: Safely remove all refrigerants from the system following proper handling procedures.

2. Use of Appropriate Recovery Cylinders: Only use approved refrigerant recovery cylinders.

- Ensure that a sufficient number of cylinders are available to accommodate the total refrigerant charge from the system.
- Designate and label each cylinder for the specific refrigerant being recovered. (e.g., cylinders specifically designed for refrigerant recovery).
- Equip recovery cylinders with a pressure-relief valve and functioning shut-off valves.
- Evacuate empty recovery cylinders. If possible, pre-cool the recovery cylinders before the process begins.

3. Recovery Equipment Requirements: The recovery equipment must be:

- In good working condition.
- Accompanied by manufacturer-provided operating instructions.
- Suitable for recovering all appropriate refrigerants, including flammable refrigerants when applicable.
- Ensure a calibrated weighing scale is available to monitor refrigerant recovery accurately.
- Equip hoses with leak-free disconnect couplings and ensure they're in good conditions.
 - Before using the recovery machine: Verify that it is in proper working order and has been properly maintained.
 - Ensure that any associated electrical components are sealed to prevent ignition in case of a refrigerant leak.
 - If in doubt, consult the manufacturer.

4. Handling Recovered Refrigerant:

It is vital to:

- Return the recovered refrigerant to the refrigerant supplier in the correct recovery cylinder.
- Arrange a waste transfer note for proper documentation and disposal.
- Do not mix refrigerants in recovery units or cylinders under any circumstances.

5. Compressor and Oil Removal:

If compressors or compressor oils need to be removed:

- Evacuate the compressor to an acceptable level to eliminate any remaining flammable refrigerant within the lubricant.
- Complete the evacuation process before returning the compressor to the supplier.
- Only use electric heating to accelerate the evacuation of refrigerant from the compressor body. Do not use open flames or ignition sources.
- When draining oil from a system, conduct the process safely and in accordance with best practices.

A2L Refrigerants

2

WARNING

- Do not use unauthorized methods to complete cleaning or accelerate defrosting. Follow only the manufacturer's recommended procedures.
- Store the appliance in a room free of continuously operating ignition sources (e.g. open flames, operating gas appliance, electric heater).
- Do not pierce or burn any part of the system.

AVERTISSEMENT

- Ne pas utiliser de moyens non recommandés par le fabricant pour accélérer le dégivrage ou nettoyer l'appareil.
- L'appareil doit être entreposé dans un endroit sans source d'allumage fonctionnant en continu (par exemple: flamme nue, appareil à gaz en marche, ou radiateur électrique en marche).
- Ne pas percer ni brûler l'appareil.
- Attention: les frigorigènes peuvent être inodores.

COMPLIANCE

- **Minimum Installation Requirements:** Install the equipment within the minimum height and room area (for both operation and storage) specified in the installation manual.
- **Risk of Fire - Auxiliary Devices:** Do not install ignition source auxiliary devices within the ductwork, unless they are specifically listed for this appliance. Refer to the installation instructions.
- **Mounting Clearance:** Mount the system with the lowest moving parts at least 8 feet (2.5 m) above the floor or grade level.
- **Risk of Electric Shock:** Serious injury or death may occur. Disconnect all remote electric power supplies before performing any service.
- **Risk of Fire - Flammable Refrigerant:** Flammable refrigerant is used. Ensure proper handling and disposal. Trained service personnel must perform maintenance and repairs. Do not puncture the refrigerant tubing.
- **Risk of Fire - Proper Disposal Required:** Dispose of the system according to all applicable federal and local regulations.
- **Risk of Fire - Service Precautions:** Flammable refrigerant is used. Refer to the service manual before attempting to service this product.
- **Risk of Fire - Compliance with Regulations:** Follow all handling instructions and comply with national regulations when working with flammable refrigerants.

USAGE STATEMENT

- Use a flammable gas detector to check for potential leaks before unloading and opening the container.
- Do not allow fire sources or smoking in the vicinity.
- Protect the pipework from physical damage. For flammable refrigerants, do not install pipes in an unventilated space if it is smaller than the minimum requirements in Annex GG. For A2L refrigerants, you must install pipes that comply with 22.116. If field charging is necessary, technicians must quantify the impact of different pipe lengths on the refrigerant charge.
- Ensure the compliance of all national gas regulations.
- Ensure that mechanical connections made in accordance with 22.118 remain accessible for maintenance.
- Protect pipework, including piping material, routing, and installation from physical damage during operation and servicing. It must comply with all national and local codes and standards, including:
 - ASHRAE 15
 - ASHRAE 15.2
 - IAPMO Uniform Mechanical Code
 - ICC International Mechanical Code
 - CSA B52
 - All field joints must be accessible for inspection before being covered or enclosed.
- After completing the field piping installation for split systems, the field pipework must undergo:
 - Pressure testing with an inert gas.
 - Vacuum testing before refrigerant charging, following the required standards.
- Store the appliance in a way that prevents mechanical damage.
- Qualified personnel must carry out maintenance, service, and repair operations according to Annex HH.
- Only competent individuals should perform safety-critical procedures, including:
 - Breaking into the refrigerant circuit
 - Opening sealed components
 - Opening ventilated enclosures

A2L Refrigerants

2

Preparation for Working on Systems with A2L Refrigerants



No flammable sources



Ventilation necessary



Wear protective gear



Do not use electronics near system



Refrigerant Leakage Detector

A handheld leak detector can aid with tracing and isolating refrigerant leaks. It is recommended to have one handy whenever working on the system.

! Determining Installation Location

Install the systems in suitable locations according to the guidelines below. For the best results, follow all the requirements for equipment placement in this manual.

Installation Site Requirements

1. Ensure Proper Ventilation

- Ventilate the installation site well to allow safe operation and prevent refrigerant accumulation.

2. Keep Away from Heat and Fire Hazards

- Keep all installation and maintenance sites for air conditioners that use R-454B refrigerant away from open flames or heat sources.
- To prevent ignition risks, technicians must avoid locations near welding activities, smoking areas, drying ovens, or any heat source exceeding 1,000°F (538°C).

3. Implement Anti-Static Precautions

- Wear anti-static clothing and gloves to prevent static discharge when handling and installing the unit.

4. Select an Accessible Installation Site

- The installation location must allow easy access for maintenance.
- Do not surround indoor and outdoor units with obstacles that restrict airflow.
- Keep away from heat sources and flammable or explosive materials.

5. Refrigerant Leak Emergency Actions

- If the indoor unit leaks refrigerant during installation, immediately shut off the outdoor unit valve.
- All personnel must evacuate the area for at least 15 minutes until the refrigerant fully dissipates.
- If the product is damaged, transport it to a maintenance station. **Note:** On-site welding or refrigerant pipe repairs are strictly prohibited.

6. Ensure Even Airflow

- Choose a location where the indoor unit's air inlet and outlet flow remain unobstructed and evenly distributed.

7. Avoid Installing Near Sensitive Areas

- Do not install the indoor unit near:
 - Electric devices or power outlets.
 - Kitchen cabinets, beds, sofas, or valuable items.
 - Areas where the airflow from the two sides of the unit could directly impact important objects.

A2L Refrigerants

2

Charging Protocol for A2L Refrigerants - If Applicable

Important Considerations

1. Qualified personnel must install and service the air conditioner. Installers must comply with all instructions set forth herein and all local regulations.
2. Use caution when handling combustible refrigerants. Careless handling can cause serious injury or property damage.
3. Conduct a leak test after completing the installation to ensure system integrity.
4. Conduct safety inspections before performing maintenance or repairs on air conditioners using combustible refrigerants to minimize fire risk.
5. Operate the system under controlled conditions to reduce the risk of combustible gas or vapor hazards.
6. The specifications in Tables GG.1 and GG.2 outline the total weight of refrigerant charge and minimum room area requirements for air conditioners.

Maximum Refrigerant Charge and Required Floor Area: The maximum charge is determined by the following equations:

$$m_1 = (6m^3) \times \text{LFL}, m_2 = (52m^3) \times \text{LFL}, m_3 = (260m^3) \times \text{LFL}$$

Where LFL is the lower refrigerant limit in kg/m³.

For R-454B refrigerant, LFL = 0.303 kg/m³.

For appliances with a charge amount $m_1 < M = m_2$:

The maximum refrigerant charge in a room must comply with: $M_{\max} = 2.5 \times (\text{LFL})^{5/4} \times h_0 \times A^{1/2}$

This value must not exceed: $M_{\max} = \text{SF} \times \text{LFL} \times h_0 \times A$

(Refer to GG.3DV for specific factors and applications.)

Minimum Floor Area Requirement: The required minimum floor area A_{\min} for an appliance with a refrigerant charge M_c (kg) must be calculated as follows:

$$A_{\min} = [M_c / (2.5 \times \text{LFL}^{5/4} \times h_0)]^2$$

However, $A_{\min} = M_c / (\text{SF} \times \text{LFL} \times h_0)$; SF = 0.5

Refer to GG.4DV for specific values/factors.

Where Category = R-454B, LFL = 0.303 kg/m³

Table GG.1 - Maximum Charge (kg)

h_0 (m)	Floor Area (m ²)	Charge Limit (kg)
1.8 (6'0")	4 (43 ft ²)	1.09 (38.5 oz)
	7 (75 ft ²)	1.91 (67.3 oz)
	10 (107 ft ²)	2.73 (96.2 oz)
	15 (161 ft ²)	3.92 (138.2 oz)
	20 (215 ft ²)	4.52 (159.6 oz)
	30 (322 ft ²)	5.54 (195.5 oz)
	50 (538 ft ²)	7.15 (252.3 oz)
2.5 (8'2")	4 (43 ft ²)	1.52 (53.44 oz)
	7 (75 ft ²)	2.65 (93.5 oz)
	10 (107 ft ²)	3.79 (133.6 oz)
	15 (161 ft ²)	5.44 (191.9 oz)
	20 (215 ft ²)	6.28 (221.6 oz)
	30 (322 ft ²)	7.7 (271.4 oz)
	50 (538 ft ²)	9.94 (350.4 oz)
2.8 (9'2")	4 (43 ft ²)	1.7 (59.8 oz)
	7 (75 ft ²)	2.97 (104.7 oz)
	10 (107 ft ²)	4.24 (149.6 oz)
	15 (161 ft ²)	6.09 (215 oz)
	20 (215 ft ²)	7.04 (248.2 oz)
	30 (322 ft ²)	8.62 (304 oz)
	50 (538 ft ²)	11.12 (392.5 oz)

A2L Refrigerants

2

Charging Protocol for A2L Refrigerants - If Applicable (Continued)

Where Category = R-454B, LFL = 0.303 kg/m³

Table GG.2 - Minimum Room Area (m²)

h ₀ (m)	Charge Limit (Kg)	Min. Room Area (m ²)
1.8 (6'0")	0.8 (28.2 oz)	2.93 (32 ft ²)
	0.95 (33.5 oz)	3.48 (38 ft ²)
	1.2 (42.3 oz)	4.4 (48 ft ²)
	1.7 (60.0 oz)	6.23 (68 ft ²)
	2.2 (77.6 oz)	8.07 (88 ft ²)
	2.8 (98.8 oz)	10.27 (111 ft ²)
	3.4 (119.9 oz)	12.47 (135 ft ²)
2.5 (8'2")	0.8 (28.2 oz)	2.11 (23 ft ²)
	0.95 (33.5 oz)	2.51 (27 ft ²)
	1.2 (42.3 oz)	3.17 (35 ft ²)
	1.7 (60.0 oz)	4.49 (49 ft ²)
	2.2 (77.6 oz)	5.81 (63 ft ²)
	2.8 (98.8 oz)	7.39 (80 ft ²)
	3.4 (119.9 oz)	8.98 (97 ft ²)
2.8 (9'2")	0.8 (28.2 oz)	1.89 (21 ft ²)
	0.95 (33.5 oz)	2.24 (25 ft ²)
	1.2 (42.3 oz)	2.83 (31 ft ²)
	1.7 (60.0 oz)	4.01 (44 ft ²)
	2.2 (77.6 oz)	5.19 (56 ft ²)
	2.8 (98.8 oz)	6.6 (72 ft ²)
	3.4 (119.9 oz)	8.02 (87 ft ²)

The standard factory refrigerant charge amount as well as the maximum allowable charge are as follows:

Table GG.3DV - Maximum Charge (g) [lbs]

Model (BTU)	R454-B Refrigerant (Standard Charge)	R-454B Refrigerant (Maximum Charge)
2-Zone (18K)	1700 g / 3.75 lbs	1950 g / 4.29 lbs
3-Zone (27K)	2200 g / 4.85 lbs	2575 g / 5.67 lbs
4-Zone (36K)	2800 g / 6.17 lbs	3300 g / 7.27 lbs
5-Zone (42K)	3400 g / 7.5 lbs	3925 g / 8.65 lbs

When connected to a multi-zone outdoor unit, the calculated minimum allowable room area for an individual indoor unit intended to be installed is:



















Table GG.4DV - Minimum Room Area (m²)

Model (BTU)	Minimum Allowable Room Area (Assumes 25 ft lineset and 6 ft install height)
YN020GLSI24M2G	6.33 m ² (68 ft ²)
YN030GLSI24M3G	8.07 m ² (88 ft ²)
YN040GLSI24M4G	10.27 m ² (111 ft ²)
YN050GLSI24M5G	12.47 m ² (135 ft ²)

! Determining Refrigerant Amount

Use the above figures when charging an empty system. The proceeding pages will also inform the reader in determining the additional refrigerant charging amounts for adjusting the factory charge when using non-standard piping length.

Suggested Tools:

Tool	Illustration	Tool	Illustration	Tool	Illustration
Standard wrench		Pipe cutter		Vacuum pump	
Adjustable / Crescent wrench		Screw drivers (Phillips & Flathead)		Safety glasses	
Torque wrench		Manifold gauge		Work gloves	
Hex keys or Allen wrenches		Level		Refrigerant scale	
Drill and Drill bits		Flaring tool		Micron gauge	
Hole saw		Clamp-on amp meter		Leak detector	

3

Outdoor Section Installation

Connect Refrigerant Piping for Multi-Circuit Condensers

Note Prior to Installation:

The process for connecting the copper refrigerant lines for indoor and outdoor units are given in the full installation manual. Repeat the process for connection and leak-checking according to the amount of zones to be installed. All pipe sets use a 1/4 inch diameter size for the liquid (smaller) side. The gas (bigger) line may require the usage of adapters to convert the 3/8 inch size to 1/2 or 5/8 inch. Use the included adapters according to the zone combination intended to be installed. Refer to the installation manual for proper torquing values.

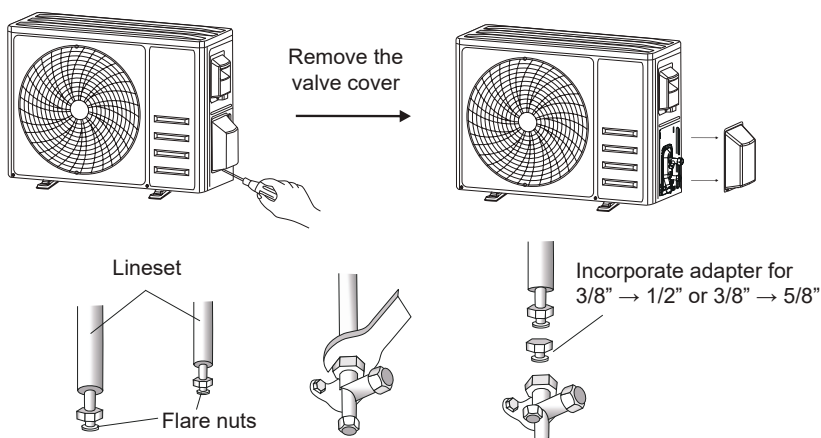

Signal Cable Wiring Diagram for Multi-Circuit Condensers

Note Prior to Installation:

Plug the connection cables to the corresponding terminals as show below. Terminal A on the outdoor unit must be connected with Terminal A on the indoor unit (B to B, and so on).

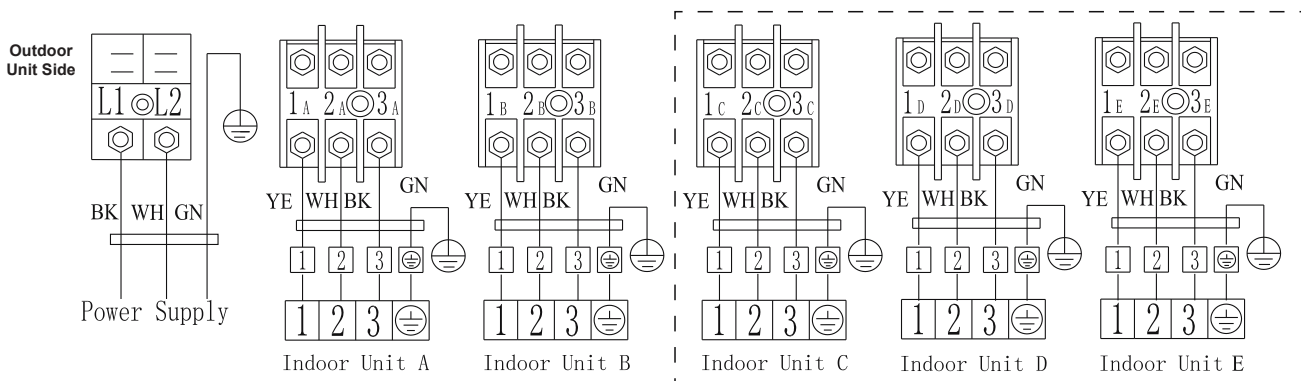

Caution

Cross-wiring is an easy mistake to make. Always double-check that the line going from a given terminal block is corresponding to the correct indoor unit.

Outdoor Section Installation

3

Allowable Connected Piping Length / Elevation Differences

Note Prior to Installation:

When installing multiple indoor units to work with a single outdoor unit, ensure that the length of the refrigerant pipe and the drop height between the indoor and outdoor units meet the requirements illustrated in the following diagram:

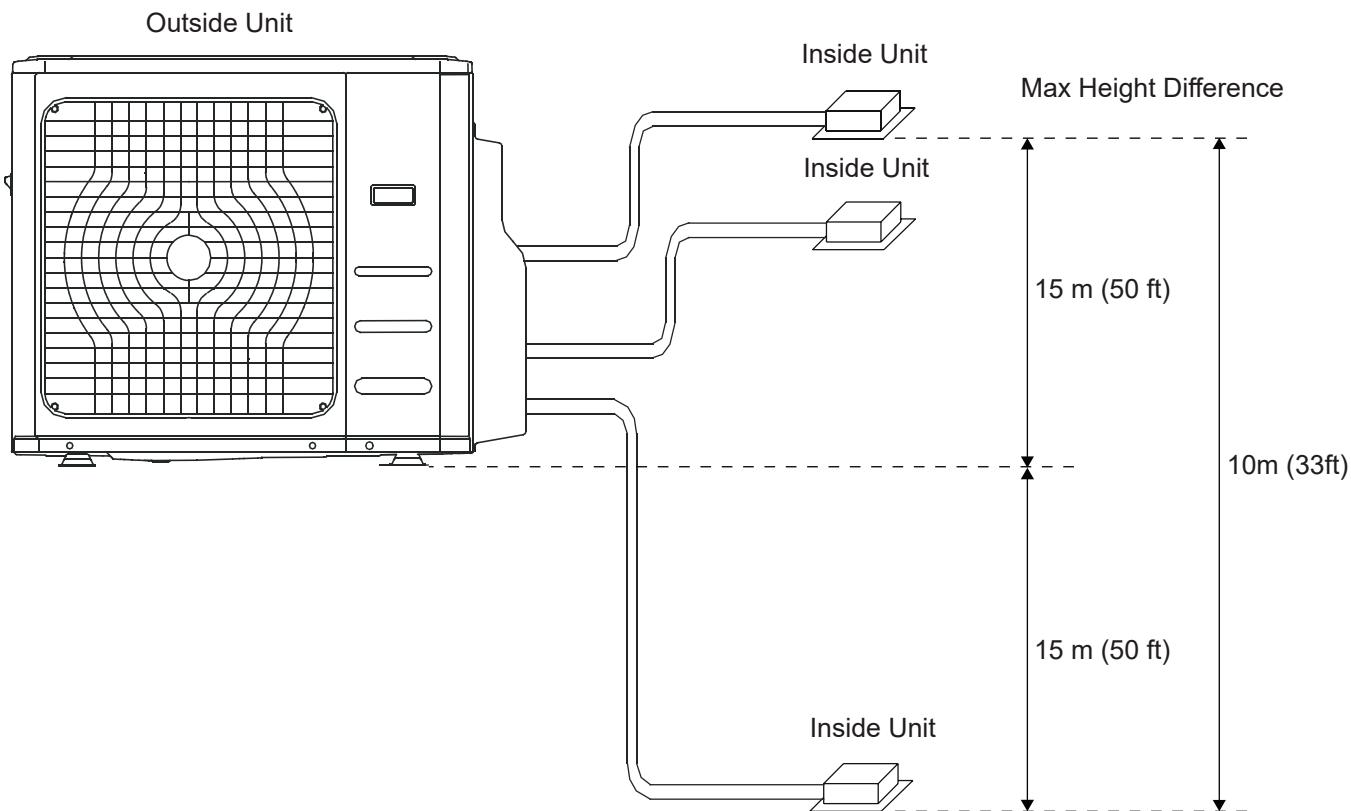

Unit Type	2-Zone	3-Zone	4-Zone	5-Zone
Max. combined length for all rooms (total attached piping)	132 ft (40 m)	200 ft (60 m)	265 ft (80 m)	300 ft (90 m)
Max. length for one indoor unit (longest zone length)	82 ft (25 m)	100 ft (30 m)	100 ft (30 m)	100 ft (30 m)
Max. elevation difference between indoor/outdoor unit	50 ft (15 m)	50 ft (15 m)	50 ft (15 m)	50 ft (15 m)
Max. elevation difference between any two indoor units	33 ft (10 m)	33 ft (10 m)	33 ft (10 m)	33 ft (10 m)
Length of total pipe supported by factory precharge	50 ft (15 m)	75 ft (22.5 m)	100 ft (30 m)	125 ft (37.5 m)
Type of refrigerant	R-454B			

For installations with connected lengths beyond standard, charge additional R-454B based on the below:

Unit Type (Model Number)	Amount of Refrigerant to Add (based on connected pipe lengths L)	
2-Zone (YN020GLSI24M2G)	0.11 oz x (L1+L2-50ft)	0.10 g x (L1+L2-15m)
3-Zone (YN030GLSI24M3G)	0.11 oz x (L1+L2+L3-75ft)	0.10 g x (L1+L2+L3-22.5m)
4-Zone (YN040GLSI24M4G)	0.11 oz x (L1+L2+L3+L4-100ft)	0.10 g x (L1+L2+L3+L4-30m)
5-Zone (YN050GLSI24M5G)	0.11 oz x (L1+L2+L3+L4+L5-125ft)	0.10 g x (L1+L2+L3+L4+L5-37.5m)

Outdoor Section Installation

3

Power Wiring Information

(Applies to 2-Zone, 3-Zone, 4-Zone, and 5-Zone Multi-Zone Systems)

1. Use a Phillips screwdriver to remove the cover wiring. Grip and gently press down to release and remove the cover.
2. Unscrew and remove the cable clamp.
3. Refer to the wiring diagram located on the inside of the wiring cover. Connect the wires to the corresponding terminals, ensuring all connections are secure and properly tightened.
4. Reinstall the cable clamp and wiring cover.

⚠ Warning: Before connecting the wiring between indoor and outdoor units, ensure the power supply is completely disconnected for 2 minutes minimally.

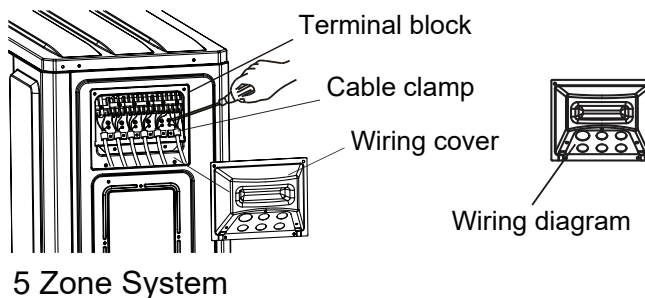
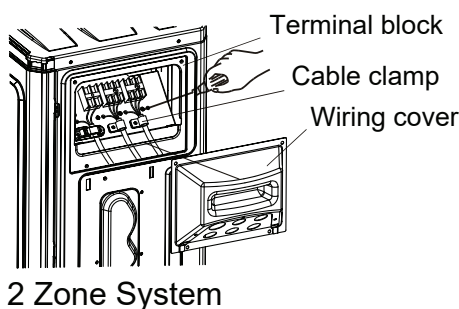

Cable Wire Specifications

Pioneer YN-L Series Multi Split		2-Zone	3-Zone	4-Zone	5-Zone
		Sectional Area (AWG)			
Power Supply Cable	L2	12 AWG	10 AWG	10 AWG	8 AWG
	L1				
Connection Cable for Communication Between Indoor & Outdoor Units	3(L)	16 AWG	16 AWG	16 AWG	16 AWG
	2(N)				
	1(S)				

- Consult the nameplate on the system for detailed electrical specifications.
- Confirm wiring based on breaker. Above power wire sizes assume largest allowable fuse.
- 203V requires a double-pole breaker (tandem-type will not work)

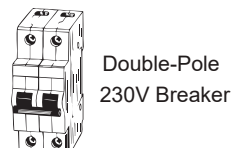

Outdoor Section Installation

3

Anchor the Outdoor Unit

The outdoor unit can be anchored to the ground or to wall-mounted brackets. The following is a list of different outdoor unit sizes and the distance between their mounting feet. Prepare the installation base of the unit according to the dimensions found below:

Model	W	D	H	X	Y
YN020GLSI24M2G (18,000 BTU / 2-Zone)	927 mm	380 mm	699 mm	586 mm	348 mm
	36- $\frac{1}{2}$ in	15 in	27- $\frac{1}{2}$ in	23- $\frac{1}{8}$ in	13- $\frac{3}{4}$ in
YN030GLSI24M3G (27,000 BTU / 3-Zone)	978 mm	421 mm	803 mm	607 mm	390 mm
	38- $\frac{1}{2}$ in	16- $\frac{5}{8}$ in	31- $\frac{5}{8}$ in	23- $\frac{7}{8}$ in	15- $\frac{3}{8}$ in
YN040GLSI24M4G (36,000 BTU / 4-Zone)	1,074 mm	468 mm	853 mm	660 mm	462 mm
	42- $\frac{1}{4}$ in	18- $\frac{3}{8}$ in	33- $\frac{5}{8}$ in	26 in	18- $\frac{1}{4}$ in
YN050GLSI24M5G (42,000 BTU / 5-Zone)	1,074 mm	468 mm	853 mm	660 mm	462 mm
	42- $\frac{1}{4}$ in	18- $\frac{3}{8}$ in	33- $\frac{5}{8}$ in	26 in	18- $\frac{1}{4}$ in

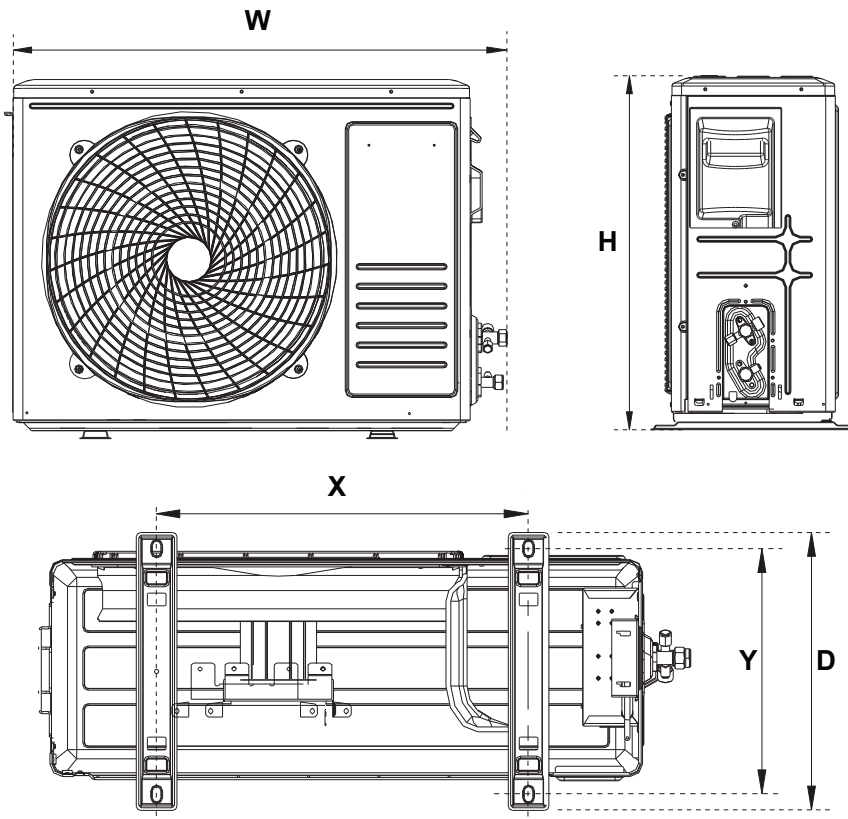

If installing the unit on the ground or a concrete mounting platform, complete the following:

1. Mark the positions for 4 expansion bolts based on the dimensions in the "Unit Mounting Dimensions" chart.
2. Pre-drill holes for the expansion bolts.
3. Clean concrete dust away from the holes.
4. Place a nut on the end of each expansion bolt.
5. Hammer expansion bolts into each hole.
6. Remove the nuts from the expansion bolts, and place the outdoor unit onto the bolts.
7. Put washers onto each expansion bolt, then replace each of the nuts.
8. Using a wrench, tighten each nut until snug.

WHEN DRILLING INTO CONCRETE, WEAR EYE PROTECTION AT ALL TIMES!

Outdoor Section Installation

3

Refrigerant Circuit Evacuation Procedures - 2-Zone

For 2-Zone systems, the evacuation protocol is identical to single-zone systems. Repeat the protocol once for the second zone. Consult the primary installation manual for the proper procedure.

Refrigerant Circuit Evacuation Procedures - 3/4/5-Zone

For 3/4/5-Zone systems, there is a set of Master (King) valves in addition to the set of valves that correspond to each respective zone/circuit. The process differs slightly. Complete the following:

Preparations and Precautions

- Air and moisture inside the refrigerant circuit can lead to pressure abnormalities, reduced efficiency, equipment damage, and safety hazards.
- Use a vacuum pump and manifold gauge to evacuate the system, removing non-condensable gases and moisture. This procedure is required during initial installation.

Before Starting Evacuation, Verify the Following:

- All high-pressure and low-pressure pipes between the indoor and outdoor units are correctly connected, as outlined in the Refrigerant Piping Connection section of the primary manual.
- All electrical wiring is securely connected, as depicted on page 13.
- A 500 PSI nitrogen leak test has been performed on all refrigerant joints. (For best results)

Evacuation Procedure

Consult the operation manuals for the manifold gauge and vacuum pump before using them, ensuring correct setup and safety.

1. Connect the Equipment

Attach the refrigerant hose from the manifold gauge's low-pressure side to the master service valve on the outdoor unit.

Connect the charge hose from the manifold gauge to the vacuum pump.

If the refrigerant lines have been installed, open all low-pressure service valves (A2, B2, C2, etc.)

⚠ Do not open any high-pressure service valves (e.g., A1, B1, C1, etc.) at this stage

2. Start the Evacuation Process

- Open the low-pressure knob on the manifold gauge. Ensure the high-pressure knob remains closed.
- Start the vacuum pump to begin evacuating the system.
- Continue vacuuming until the compound gauge reads -76 cmHg (-29.92 inHg or -101 kPa).
- For the best results, use a micron gauge and continue evacuating until the system pressure drops to 500 microns or less. Ideal target: 350-500 microns.

Outdoor Section Installation

3

Refrigerant Circuit Evacuation Procedures - 3/4/5-Zone (Continued)

3. Stabilize and Check

- After the target vacuum is reached, close the low-pressure knob on the manifold and turn off the vacuum pump.
- Wait 10-15 minutes (ideally 1 hour), then verify that the system vacuum reading remains steady.
- If available, use a micron gauge to confirm that the pressure is still below 500 microns.

4. Leak Check and Final Valve Operation

A. If the vacuum level rises, refer to the Gas Leak Check section in the primary installation manual for information on inspecting for leaks.

B. If a leak is confirmed, remove the charge hose and repair the leakage point before repeating evacuation.

C. Once the vacuum holds, use an Allen wrench to fully open the master valves (M1, M2) and high-pressure service valves (A1, B1, C1, etc.)

D. Tighten all valve caps by hand (master valve, high-side, and low-side service valves)

E. If necessary, use a torque wrench for a more secure seal.

Important Notes:

- Always slowly open the service valves.
- When opening the valves, turn the Allen wrench until it meets resistance from the stopper. Do not over-tighten.

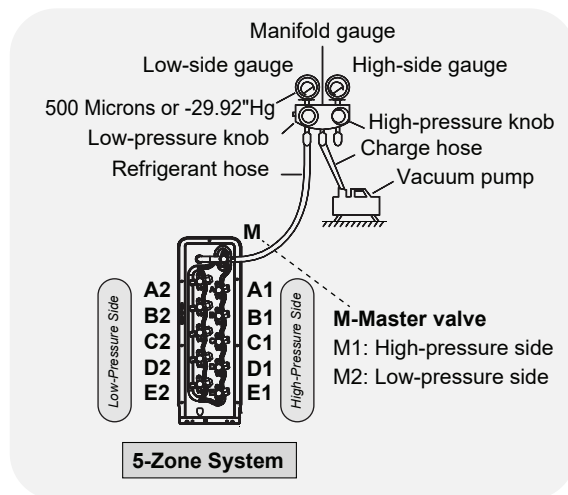
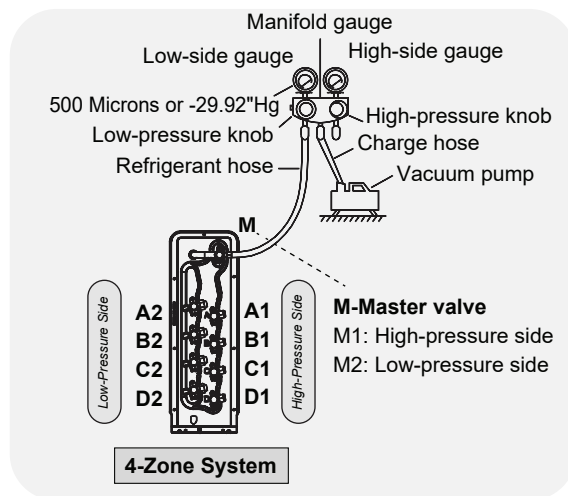
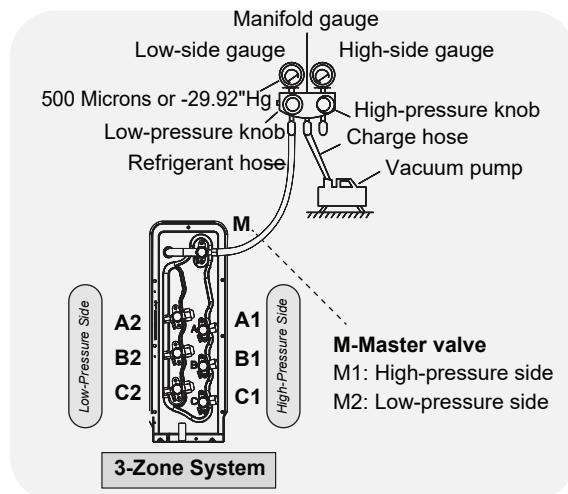
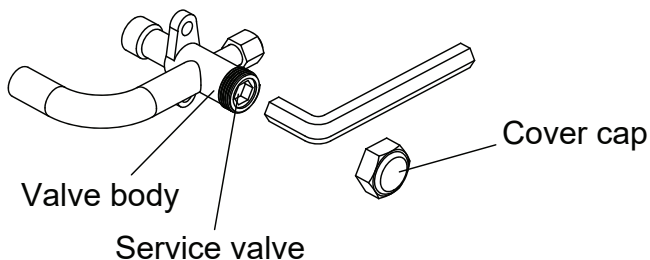

Appendix



Outdoor Condensing Unit Control Board Wiring Diagrams

Outdoor Unit: YN020GLSI24M2G

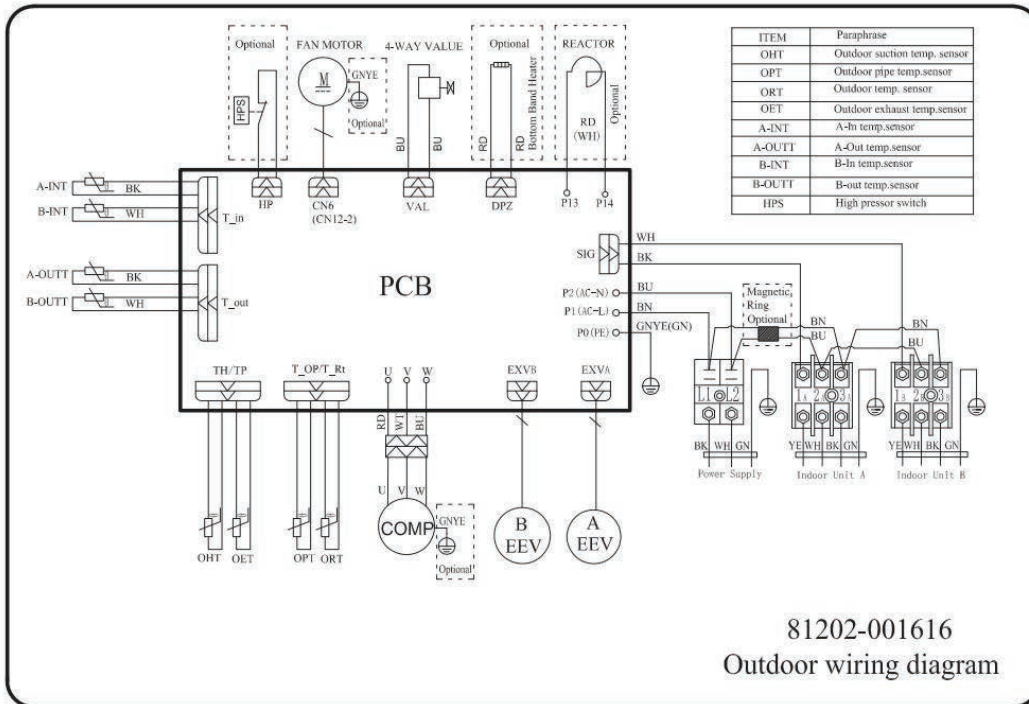

Outdoor Unit: YN030GLSI24M3G

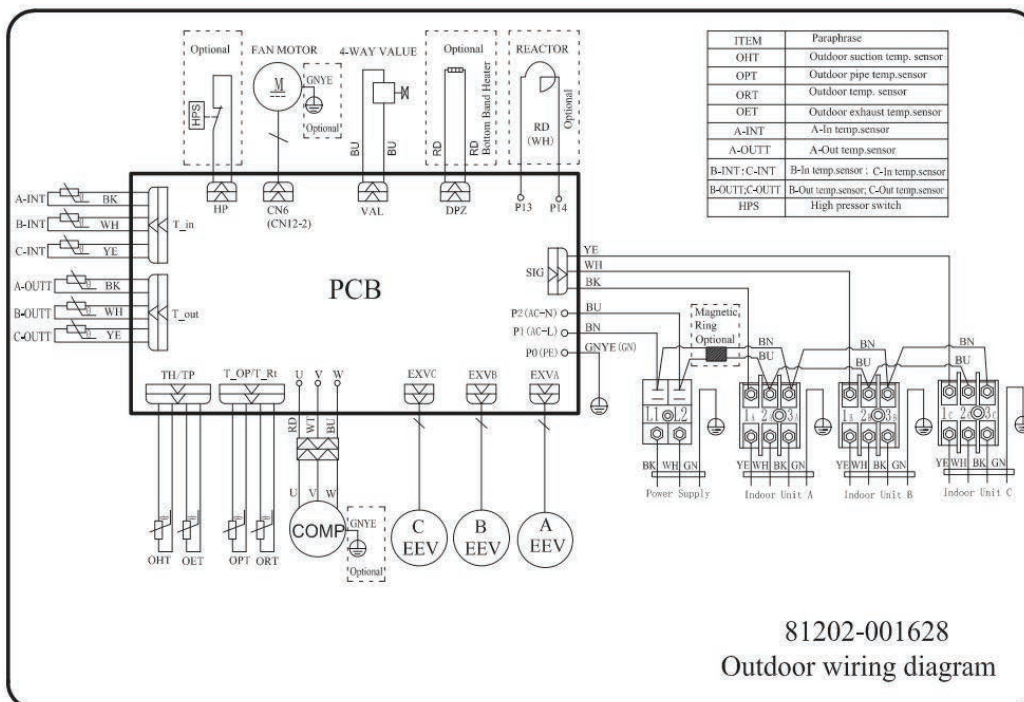

Appendix



Outdoor Condensing Unit Control Board Wiring Diagrams

Outdoor Unit: YN040GLSI24M4G

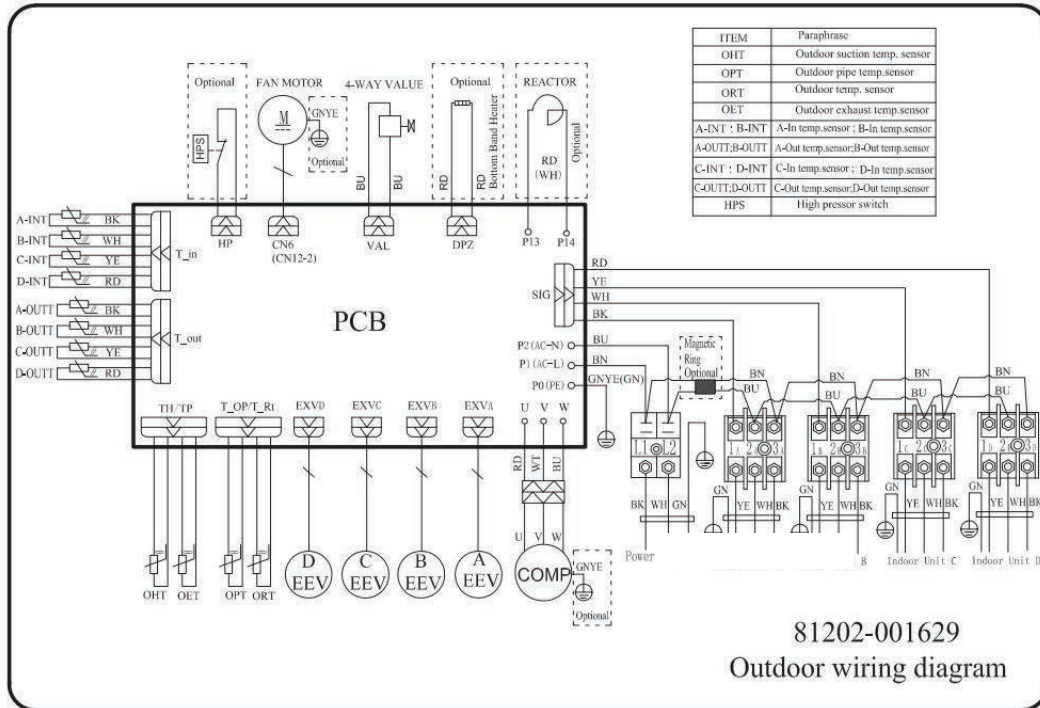

Outdoor Unit: YN050GLSI24M5G

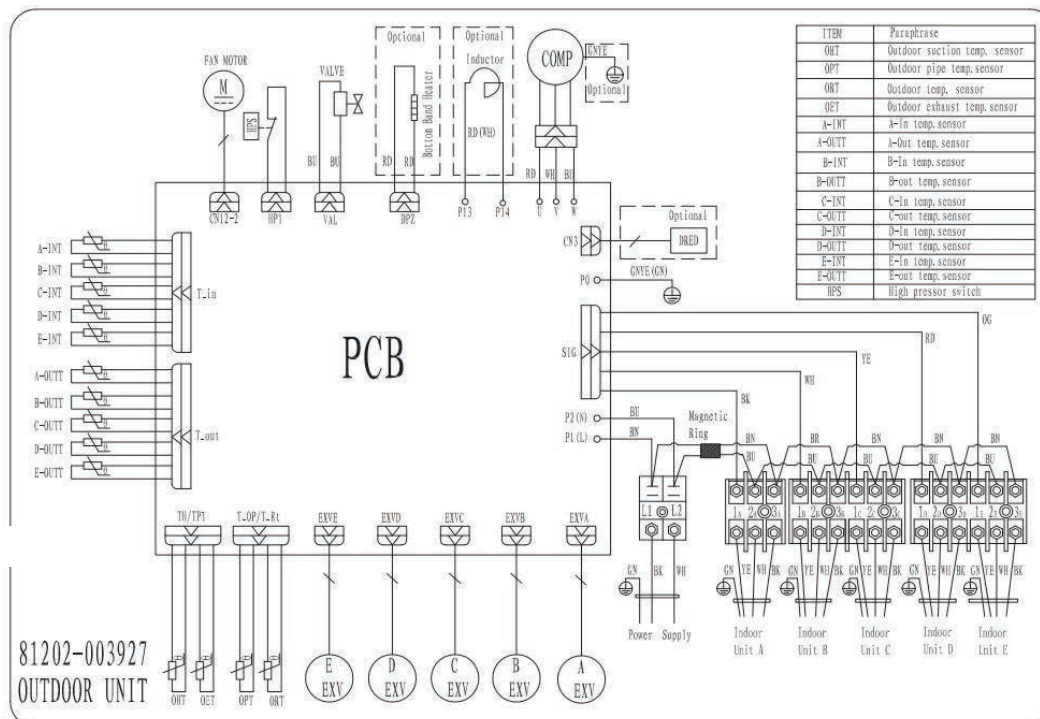

Appendix

A

Product Disposal Guidelines

This appliance contains refrigerant and other potentially hazardous materials. When disposing the appliance, the law requires special collection and treatment. Do not dispose this product as household waste or unsorted municipal waste.

Remove all refrigerant and oil prior to disposal as outlined within this manual.

When disposing of this appliance, the following options are available:

- Dispose of the appliance at a designated municipal electronic waste collection facility.
- When buying a new appliance, the retailer will take back the old appliance free of charge.
- The manufacturer will take back the old appliance free of charge.
- Sell the appliance to certified scrap metal dealers.

Special Notice

Disposing of this appliance improperly, or in other natural surroundings, endangers your health and is bad for the environment. Hazardous substances may leak into the ground water and enter the food chain. Follow proper disposal protocols.

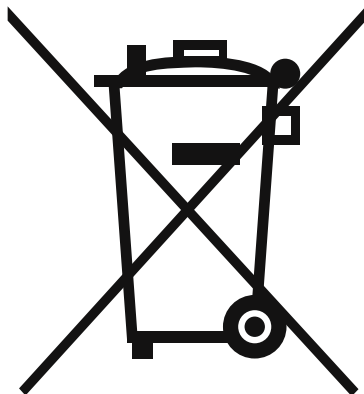

Appendix



If Refrigerant Has Been Added to the System During Installation

(For the Installer) fill in the following:

- 1) The factory refrigerant charge of the product (located on the outdoor unit nameplate).
- 2) The additional refrigerant charged into the product.
- 1+2) The total refrigerant charge.

① =		ozs (kg)
② =		ozs (kg)
① + ② =		ozs (kg)

We recommend keeping this information handy for future service and maintenance needs.

System Notes

The design and specifications of this product are subject to change without prior notice as development continues. Consult with the sales agency or manufacturer for details. Refer to the equipment nameplate for all other applicable specifications.



is a registered trademark of Parker Davis HVAC International, LLC.

Parker Davis HVAC International
7290 NW 77 Court, Miami, FL 33166 - USA
Tel : (305) 513-4488
Fax : (305) 513-4499
E-mail : info@pdhvac.com
Website: www.pdhvac.com

Pioneer product line, parts, and supplies are available online for convenient ordering at:
www.highseer.com
www.pioneerminisplit.com

Scan the below code to visit our support page where you can find more installation materials:



Copyright 2025, Parker Davis HVAC International, LLC., All rights reserved.
