

READ ME ! ⚠

Thank you for purchasing a Slimpro Rack Decking Panel Medium.

Before you start, take a moment to familiarize yourself with the Fitting Instructions and the included components.

Refer to Page 2 for a list of all the components, quantities and tools required.

IMPORTANT WARNING! ⚠

IT IS CRITICAL THAT ALL FRONT RUNNER PRODUCTS BE PROPERLY AND SECURELY ASSEMBLED AND ATTACHED TO YOUR VEHICLE. IMPROPER ATTACHMENT COULD RESULT IN AN AUTOMOBILE ACCIDENT, AND COULD CAUSE SERIOUS BODILY INJURY OR DEATH. YOU ARE RESPONSIBLE FOR ASSEMBLING AND SECURING ALL FRONT RUNNER PRODUCTS TO YOUR VEHICLE, CHECKING THE ATTACHMENTS PRIOR TO USE, AND PERIODICALLY INSPECTING THE PRODUCTS FOR ADJUSTMENT, WEAR AND DAMAGE. THEREFORE, YOU MUST READ AND UNDERSTAND ALL OF THE INSTRUCTIONS AND PRECAUTIONS SUPPLIED WITH YOUR FRONT RUNNER PRODUCT PRIOR TO INSTALLATION OR USE. IF YOU DO NOT UNDERSTAND ALL OF THE INSTRUCTIONS AND CAUTIONS, OR IF YOU HAVE NO MECHANICAL EXPERIENCE AND ARE NOT THOROUGHLY FAMILIAR WITH THE INSTALLATION PROCEDURES, YOU SHOULD HAVE THE PRODUCT INSTALLED BY A PROFESSIONAL INSTALLER OR OTHER QUALIFIED PERSONNEL.

NOTE: Front Runner will not be responsible for any damage caused by the failure to install the product according to these instructions.

Please call us if you have any questions about the installation of this product.

1

GET ORGANIZED

IN THE BOX

1	1 X	Slimpro Decking Panel Medium
2	1 X	Medium Decking Panel Spacer
3	1 X	M6x16 Button Head Bolt
4	1 X	M6x12x1 Flat Washer
5	1 X	M6 Nyloc Nut
6	1 X	M6 Nut Cap
7	6 X	M8x20 Hex Bolt
8	6 X	M8x16x1.6 Flat Washer
9	6 X	M8 Nyloc Nut
10	6 X	M8 Nut Cap

TOOLS NEEDED



FIGURE 1.1

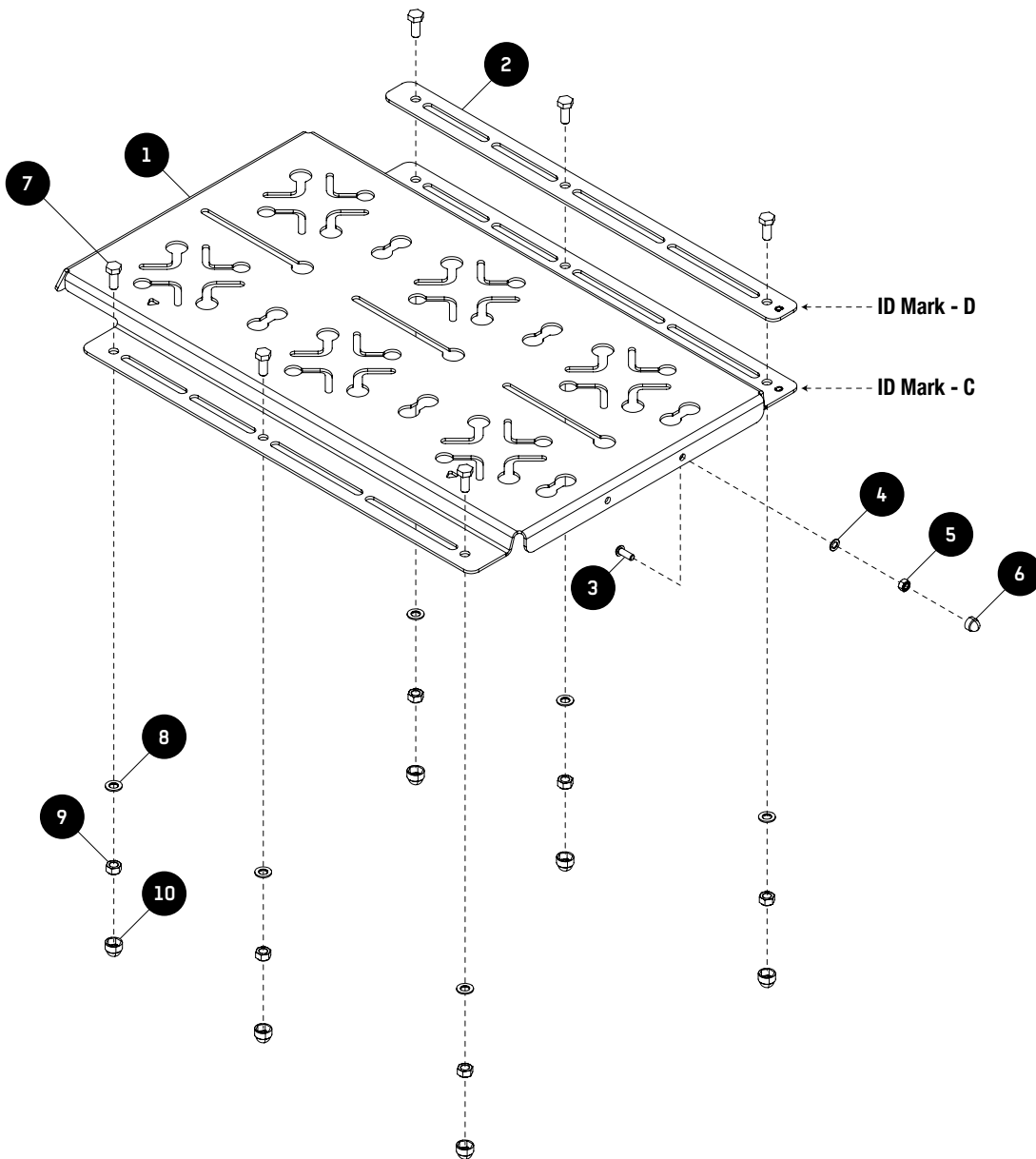

1

FIT AND SECURE

1.2

Before starting the assembly, take note of the mounting options below.

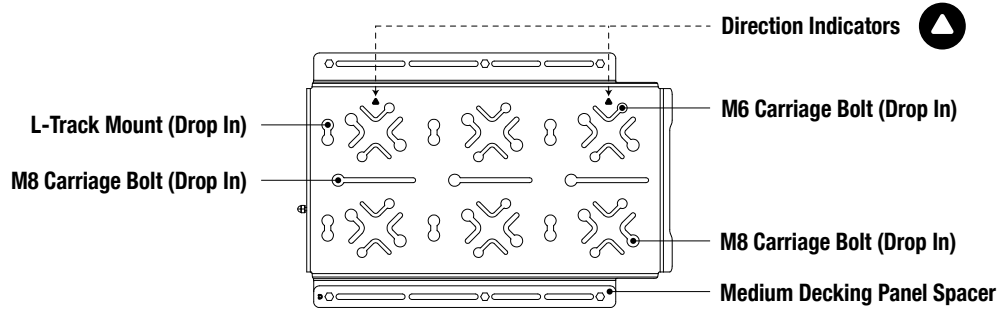

RRAC996 (Sold Separately) - 4 Pcs

RRAC997 (Sold Separately) - 4 Pcs

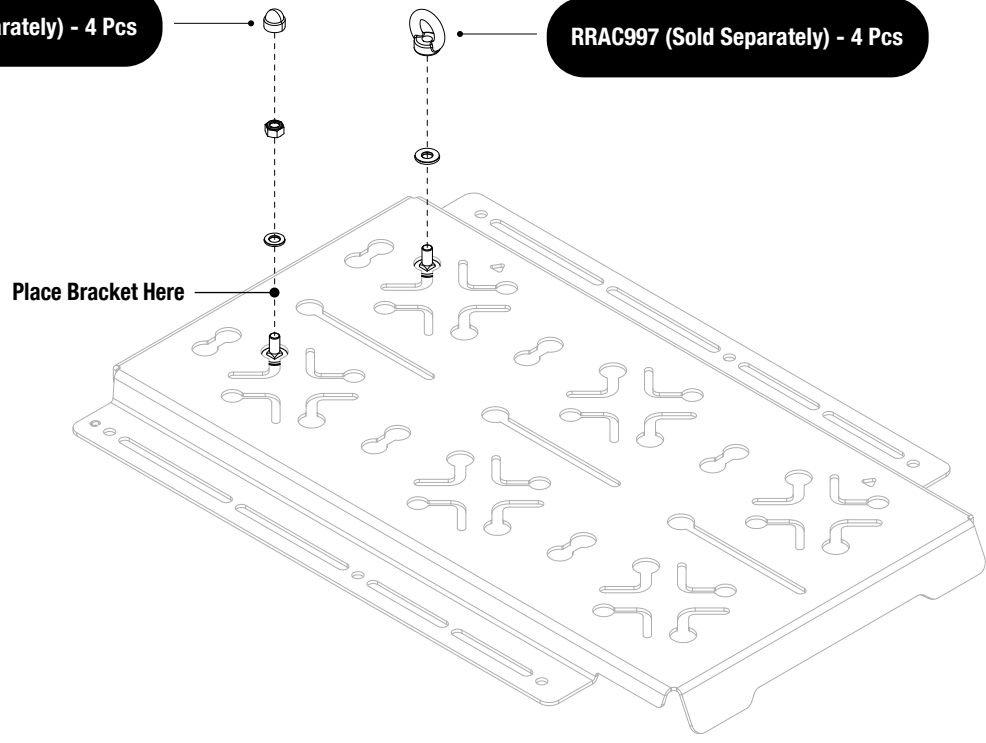

2

FIT AND SECURE - ROOF TOP AC / POP UP VENT CONFIGURATION

2.1

Before starting the assembly, take note of the configuration options below.

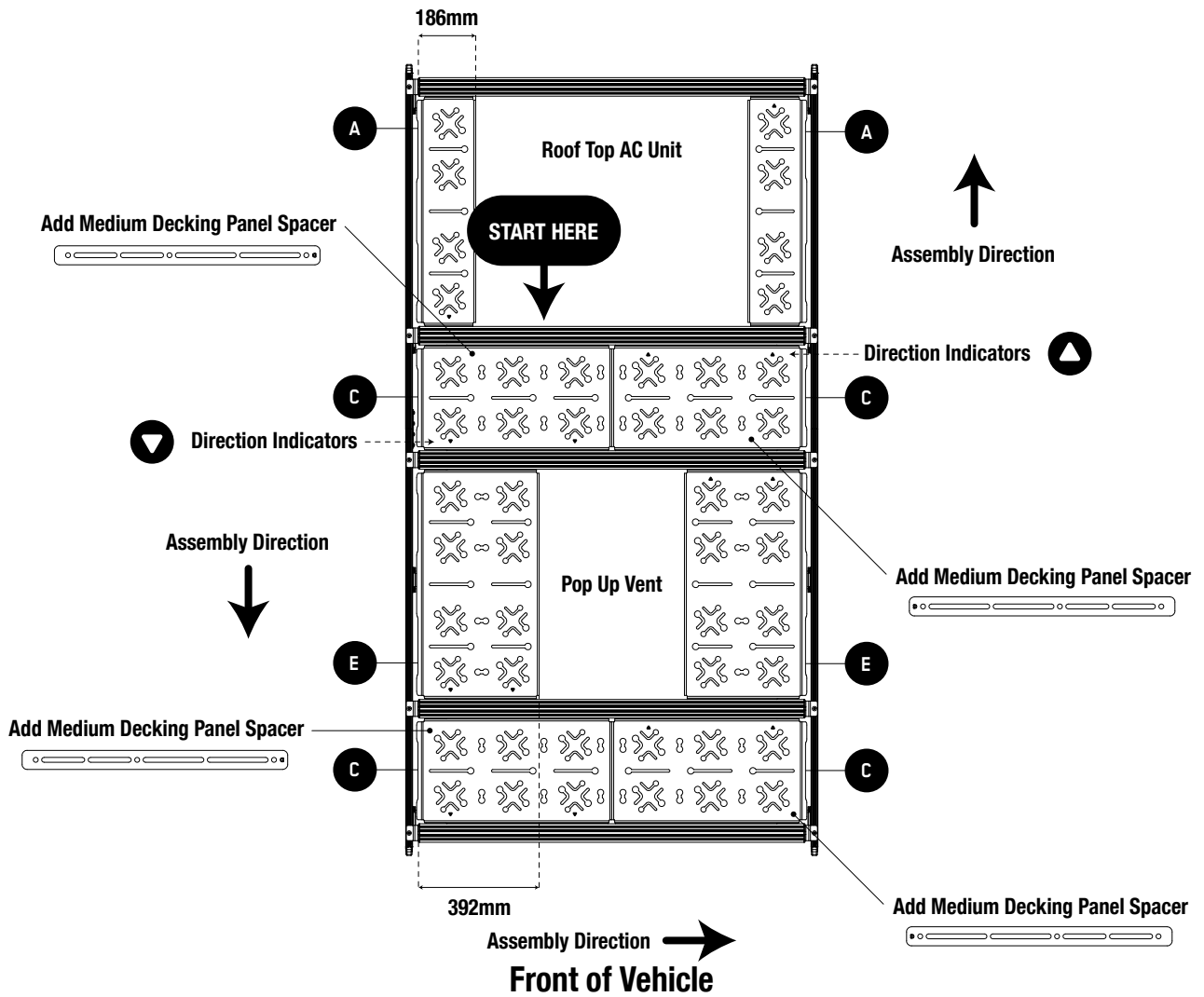

TIP: When multiple Decking Panels are installed, always start with Decking Panel C, followed by Decking Panels A & E.

2

FIT AND SECURE - FULL DECK CONFIGURATION

2.2

Before starting the assembly, take note of the configuration options below.

Add Medium Decking Panel Spacer



START HERE

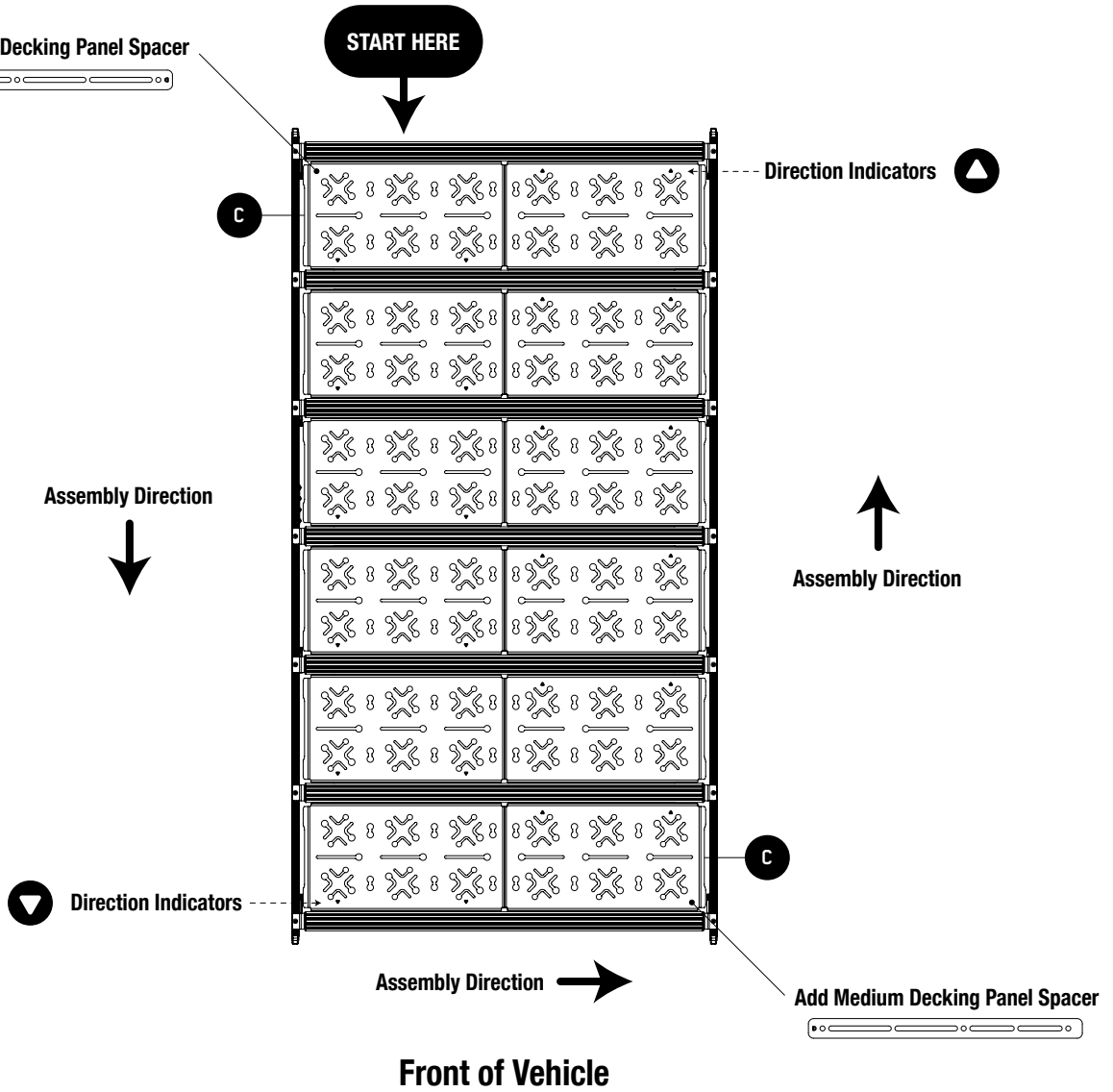

TIP: When multiple Decking Panels are installed follow the U shaped assembly directions as indicated.

2

FIT AND SECURE

2.3

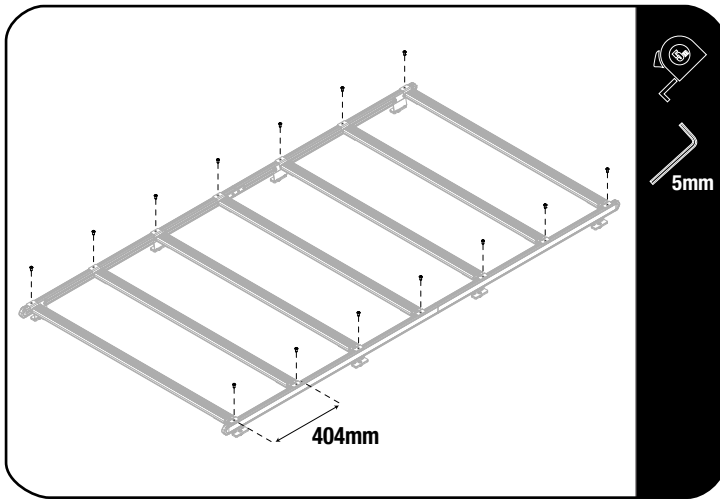

Loosen the Button Head Bolts on the side profiles to allow the slats to slide and be positioned where needed.

To fit the Slimpro Decking Panel Medium (Item 1) the slats need to be mounted 404mm apart as shown.



To assist with the fitment, remove the slats the decking panels will be fixed too.

2.4

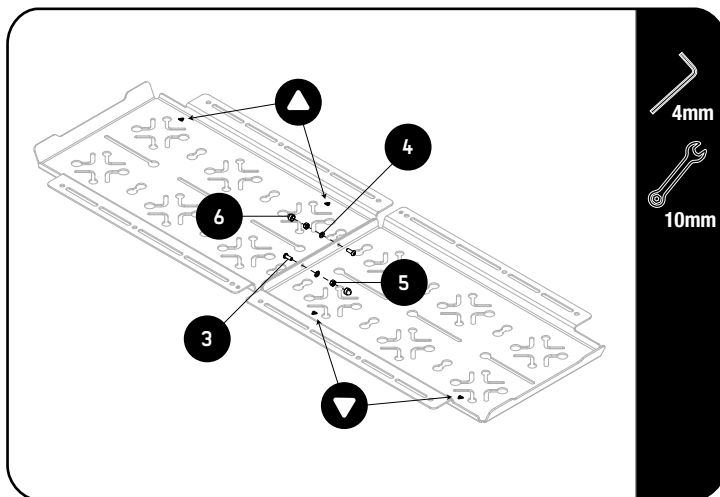

Skip this step if you prefer a gap in the middle between the panels.



Take note of the decking panel orientation when two decking panels are joined, as shown by the direction indicators.

Fully tighten the M6x16 Button Head Bolts, M6x12x1 Flat Washers, M6 Nyloc Nuts & M6 Nut Caps (Item 3, 4, 5 & 6) as shown.

2.5

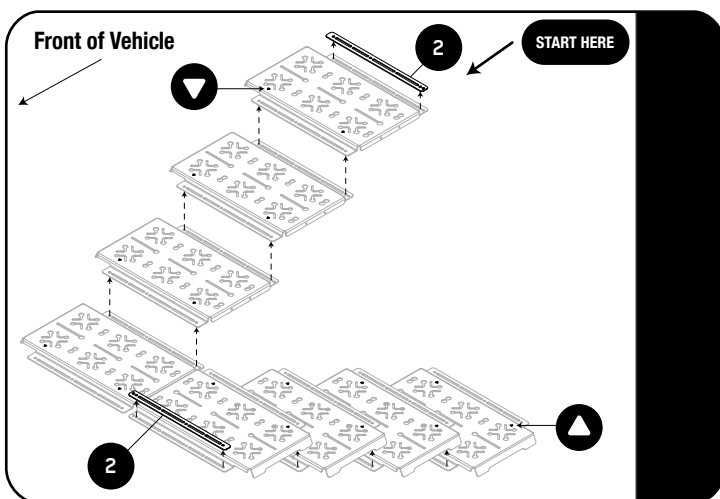

Before starting the assembly take note of how the Slimpro Decking Panel Medium & Medium Decking Panel Spacer are stacked.

The direction indicators will be used to identify which side of the decking panel will overlap the decking panel behind it.



Always start the assembly from the rear of the vehicle when a full deck is required.



TIP: The Medium Decking Panel Spacer (Item 2) will only be required where no additional decking panels are stacked.

2.6

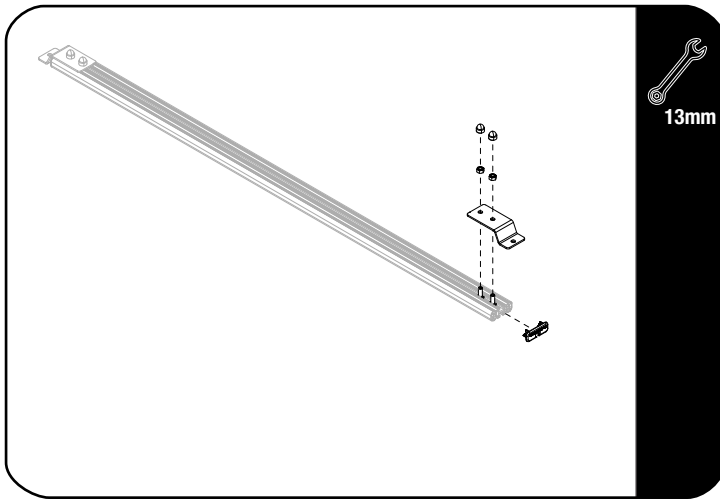

The assembly of the decking panels to the slats should be done on a suitable surface off of the vehicle whenever possible.

The sub-assembly can be installed to the rack as one piece.



Remove the Z-Bracket from one of the sides of the slat by removing the M8 Nut Caps and loosening the M8 Nyloc Nuts holding the Z-Bracket in place.

Remove the End Cap to open up the T-slot.

Repeat this step on two slats for each decking panel to be stacked.

2.7

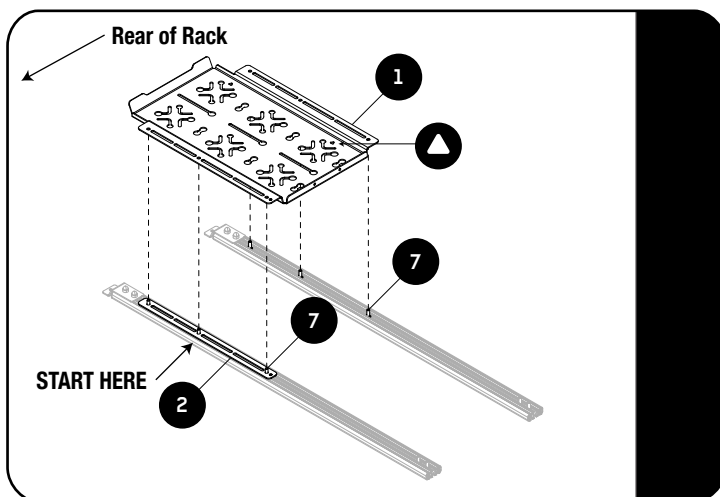

Slide three M8x20 Hex Bolts (Item 7) into the T-slot of each slat as shown.

Place the Medium Decking Panel Spacer (Item 2) in between the Slimpro Decking Panel Medium (Item 1) and the slat as shown.

Place the Slimpro Decking Panel Medium (Item 1) onto the slats by passing the bolts through the round holes as shown.



NOTE: Image shows the slats top face down.

2.8

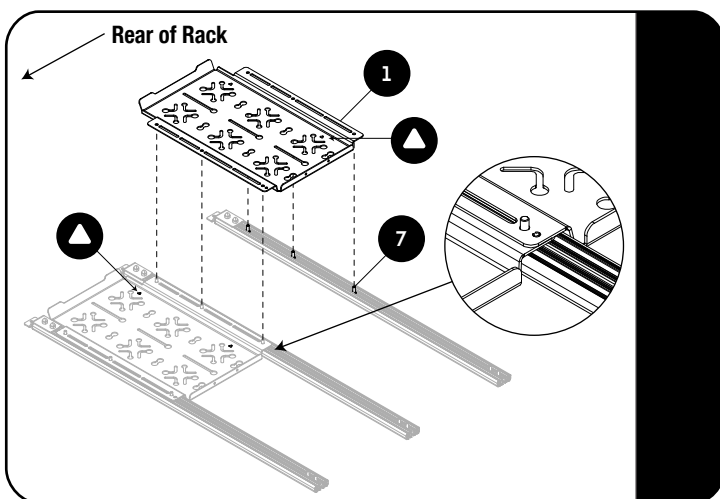

Slide three M8x20 Hex Bolts (Item 7) into the T-slot of the next slat as shown.

Place the Decking Panel (Item 1) onto the slats by passing the bolts through the round holes as shown, note the overlap of the decking panels.

Ensure that the direction indicators face the same direction.



Repeat the above step for additional stacked decking panels.

2.9

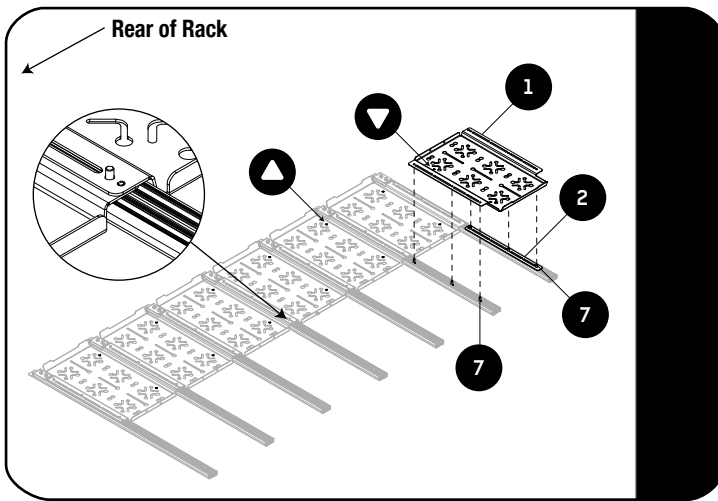

The front decking panel will require the Medium Decking Panel Spacer.



Slide three M8x20 Hex Bolts (Item 7) into the T-slot of each slat as shown.

Place the Medium Decking Panel Spacer (Item 2) in between the Slimpro Decking Panel Medium (Item 1) and the slat as shown.

Rotate the Slimpro Decking Panel Medium (Item 1) for the next row 180° so that the direction indicator now faces the rear. Place the Slimpro Decking Panel Medium (Item 1) on the slat.

2.10

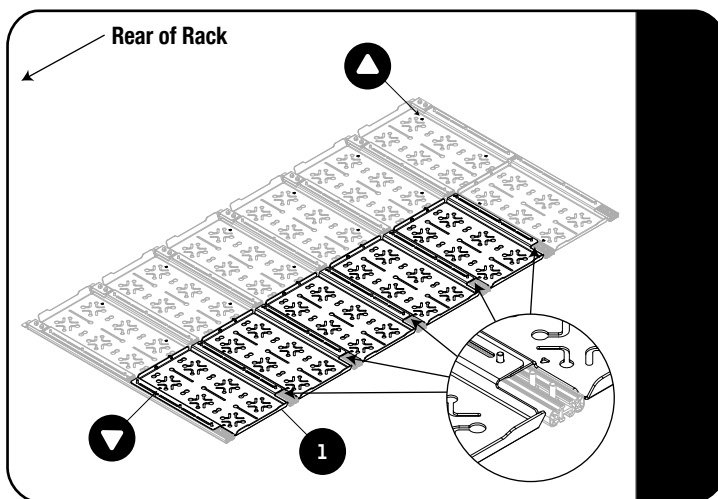

Repeat Step 2.8 for each stacked Slimpro Decking Panel Medium (Item 1) making sure the direction indicator faces the rear.



If you prefer to join the Slimpro Decking Panels revert to Step 2.4.

2.11

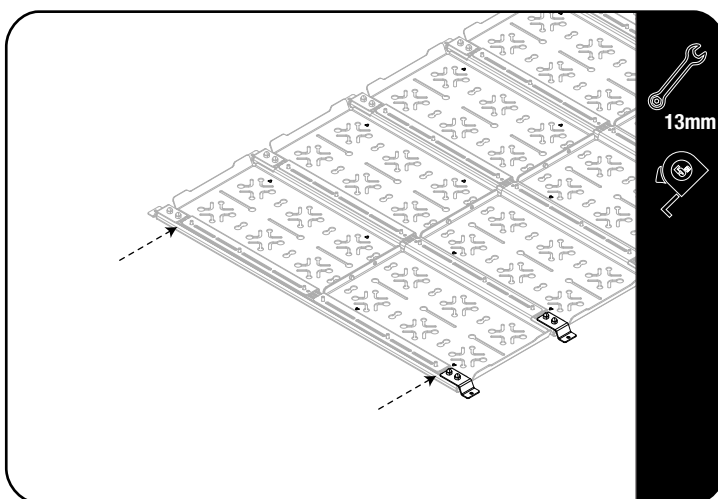

Reassemble the Z-Brackets to the slats that was removed in Step 2.6.

Measure equal distances on both sides of the decking panels and adjust the spacing if needed.

2.12

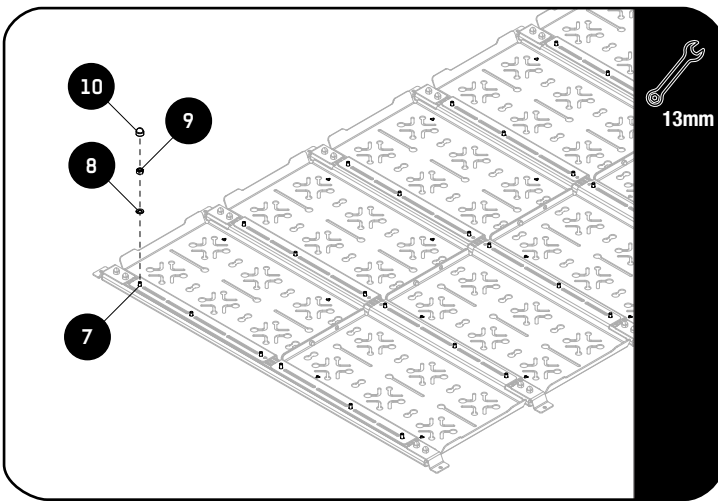

Fully tighten the Slimpro Decking Panel Medium (Item 1) to the slats by using M8x16x1.6 Flat Washers, M8 Nyloc Nuts (Item 8 & 9) for all of the M8x20 Hex Bolts (Item 7).



Tightening Torque:

M8 : 15-20Nm / 11.06 ft lb - 14.75 ft lb

Place all of the M8 Nut Caps (Item 10) over the M8 Nyloc Nuts (Item 9).

The decking panel assembly will be flipped over before reassembling to the Slimpro Rack.

2.13

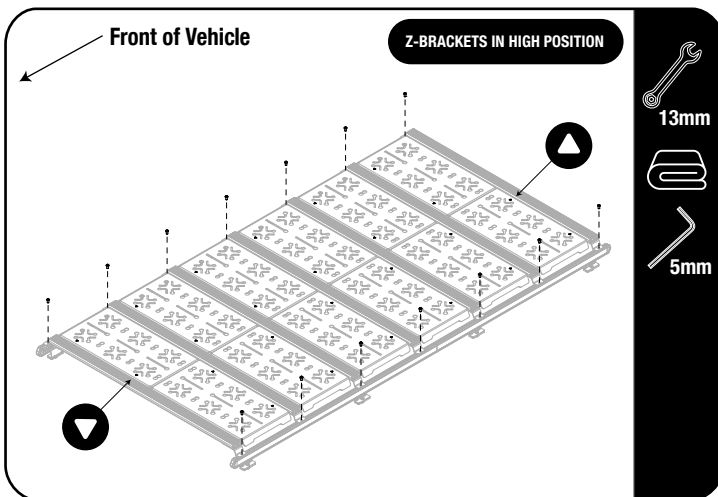

Use a blanket to protect the vehicle roof before positioning and re-fitting the sub-assembly to the Slimpro Rack.



NOTE: The direction of the Direction Indicators to correctly orient the Decking Panel Assembly.

Reassemble the Z-Brackets to the Side Profiles in the high position on the Slimpro Rack.



When a full deck is required, split the decking panel sub-assembly into multiple smaller assemblies that can be safely lifted onto the roof of the vehicle.

2.14

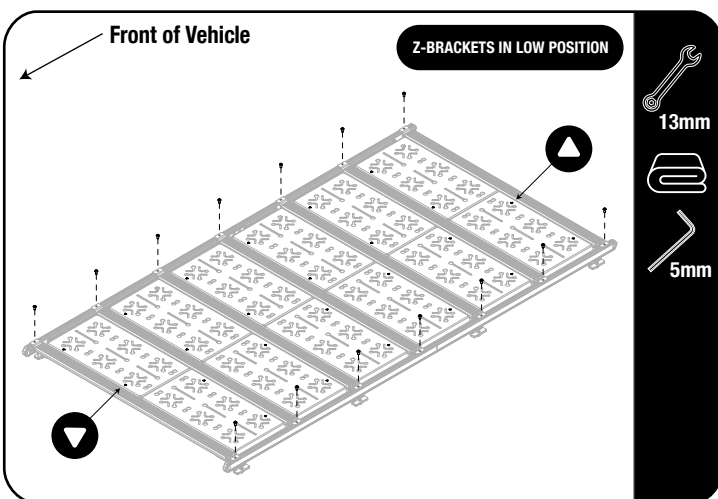

Use a blanket to protect the vehicle roof before positioning and re-fitting the sub-assembly to the Slimpro Rack.



NOTE: The direction of the Direction Indicators to correctly orient the Decking Panel Assembly.



Reassemble the Z-Brackets to the Side Profiles in the low position on the Slimpro Rack.



When a full deck is required, split the decking panel sub-assembly into multiple smaller assemblies that can be safely lifted onto the roof of the vehicle.

2

FIT AND SECURE

2.15

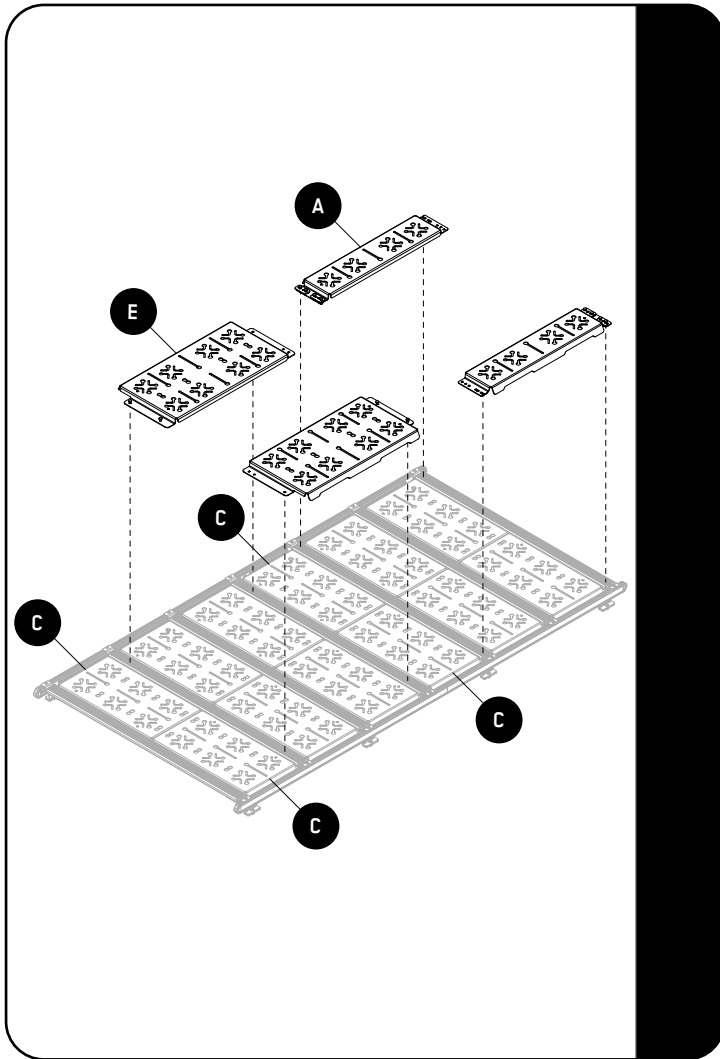

To fit the Slimpro Decking Panel Small - ID Mark A (RRAC368) and Slimpro Decking Panel Large - ID Mark E (RRAC370) refer to the corresponding fitment guides.



NOTE: The Slimpro Decking Panel Small (A) / Large (E) must be used with the Slimpro Decking Panel Medium (C) as shown.

3

FINISH

Congratulations! You did it. Take a step back and admire your work!

4

INSTALL OTHER VEHICLE AND RACK ACCESSORIES

Now's the time to visit your favorite Front Runner Dealer in person or online.

Be sure to tag us. We love to see our gear in action! #FrontRunnerOutfitters

Share your adventures on:

